

HEPAbox

Plenum box for cleanrooms

Technical Documentation

Installation, Commissioning, Operation, Maintenance and Service Manual

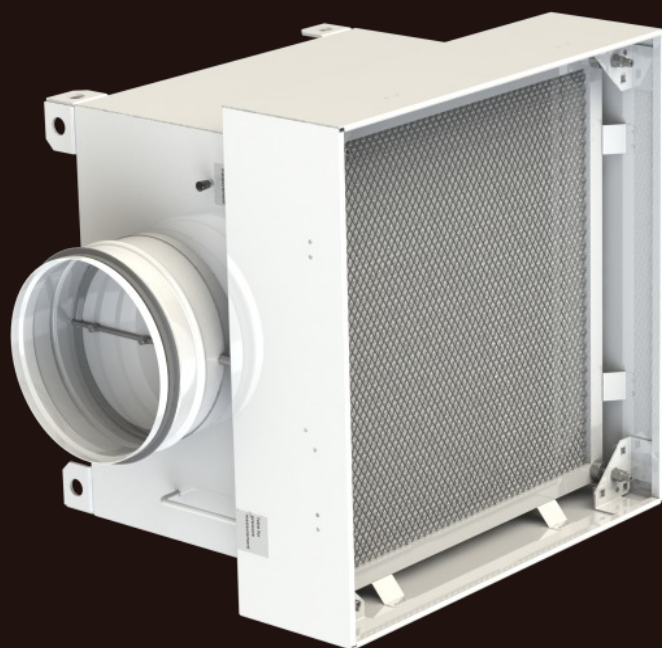

These technical conditions specify a number of produced sizes of the HEPAbox plenum boxes for clean areas (hereinafter referred to as the “box”). They apply to production, design, ordering, delivery, assembly, and operation.

CONTENT

I. GENERAL.....	3
Description.....	3
Design.....	4
Dimensions and weight of box / filter.....	5
Horizontal position of the connecting sleeve.....	5
Vertical position of the connecting sleeve.....	6
Dimensions and weights of front panels and diffusers.....	7
VVPM front plate (fixed slats).....	7
DVCM front plate (square/round).....	7
VNM diffuser (adjustable slats).....	8
RAG45 diffuser (slats in fixed position of 45°).....	8
SMM wall grille (fixed slats - spacing 12,5mm or 20mm).....	9
Ceiling frames.....	10
Materials and components.....	11
Used materials.....	11
HEPA filters.....	11
II. TECHNICAL DATA.....	12
Pressure drop.....	12
Air flow rate, pressure drop.....	12
Acoustic data.....	13
III. INSTALLATION, OPERATION, MAINTENANCE.....	14
Installation and commissioning.....	14
Installation of frames in the ceiling structure.....	16
Operation and maintenance.....	17
Filter Replacement.....	17
Cleaning and disinfection.....	18
Ecologic liquidation.....	19
IV. PACKAGING, TRANSPORT, STORAGE, WARRANTY.....	19
Logistic data.....	19
Warranty.....	19
V. ORDERING INFORMATION.....	20
Ordering key - HEPAbox.....	20
Ordering key - accessories.....	21
Front plate.....	21
HEPA filter.....	21
Installation frame.....	21
VI. PRODUCT INFORMATION.....	22
Data label.....	22

I. GENERAL

Description

Plenum box is intended to be used as the terminal unit of HVAC systems for cleanrooms as hospitals, laboratories, process cleanrooms etc.

Plenum box can be installed not only in the closed ceilings but also independently; this applies even for design with a closing flap.

The box consists of a container from stainless steel with round connecting sleeve, filter mounting brackets, channels

(tubes) for differential pressure and filter integrity inspection, outlet anemostat or grille, and from an optional manual closing flap. Box surfaces are protected by a special powder paint.

The delivery package includes a high performance HEPA filter with integral PUR gasket, anodized aluminum frame and protection grid from both sides.

The box shows the following main features

- all-welded stainless-steel container for high stiffness, tightness, and reliability
- hygienic design in accordance the most advanced Standards for HVAC system in hospitals
- top performance and quality HEPA filters of AAF brand with very low pressure drop
- low noise emissions
- environment friendly design
- easy installation, commissioning, diagnostics and filter replacement.

Specifications

- square front with the nominal side length of 400, 500, 600, 625 mm
- plenum box for frame filters with the frame depth of 34 ... 80 mm
- volume flow rate with the standard delivered HEPA filter up to 1440 m³/h (400 l/s)
- intended for filters with filtration class up to H14
- standard delivered filter of H14 class (HEPA filter) of AAF brand
- pressure in the chambre (end pressure drop) of 500 Pa max
- 6 types of outlet anemostats/grilles offered
- design in accordance with the following general and hygienic Standards
 - VDI 6022, sheet 1 (01/2018)
 - VDI 3803, sheet 1 (05/2020)
 - ÖNORM H 6021 (08/2016)
 - SWKI VA105-01 (08/2015)
- design in accordance with the following standards for hospitals, medical labs etc.
 - DIN 1946, part 4 (09/2018)
 - ÖNORM H 6020 (06/2019)
 - SWKI VA104-01 (01/2019)
- conformity assessed by Hygiene-Institut des Ruhrgebiets, Germany, Test report number W-355575-22-Zd, Certificate issued on 28.04.2022
- defectoscopy tested according to EN ISO 14644-3: 2019 by an accredited laboratory No. 1313.
- flap tightness class 4 in acc. with EN 1751: 2014
- container material and anemostat/grille material reaction to fire class A1.

Design

- Plenum box is equipped with an inlet connecting sleeve oriented horizontally or vertically.
- Horizontal connecting sleeve may be equipped with a closing flap with closed blade leakage class 4 in acc. with EN 1751.
- The flap control lever is accessible from the inside of the filter chamber (accessible from the room after anemostat/grille removal). The flap lever also prevents the filter being removed with the flap open.
- The filter being inserted, filter centering springs guide the filter frame to the right spot. Then, the filter is secured by 4 adjusting bolts in filter mounting brackets.
- HEPAbox may be equipped by one of two front panels: whirling anemostat VVPM or punched front panel DVCM. The front panels are adapted to HEPAbox and both are fixed by 6 bolts M6.
- In addition to those two options, HEPAbox may be equipped by a grille with adjustable fins VNM, SMM fixed slats or by a grille with 45° fixed fins RAG45. The grilles are adapted to HEPAbox and are fixed using 8 bolts M4.



Box without HEPA filter



Box with HEPA filter

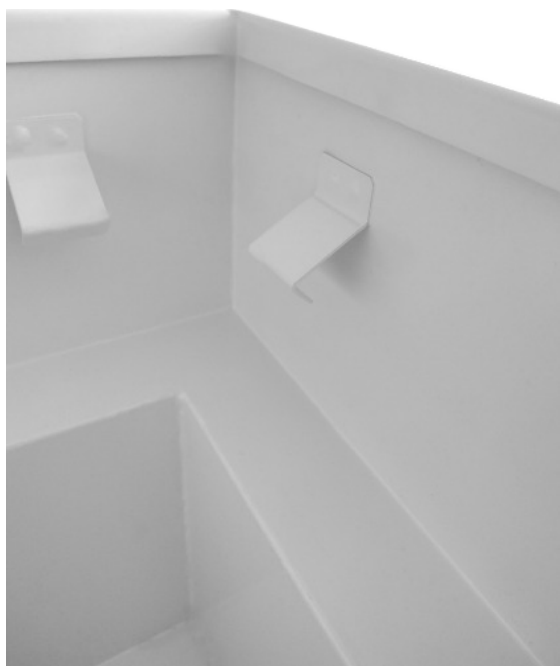

The internal flange on which the filter sealing rests and the leaf springs, mounted inside from the side of the box, serving to retain the filter and make the installation easier.

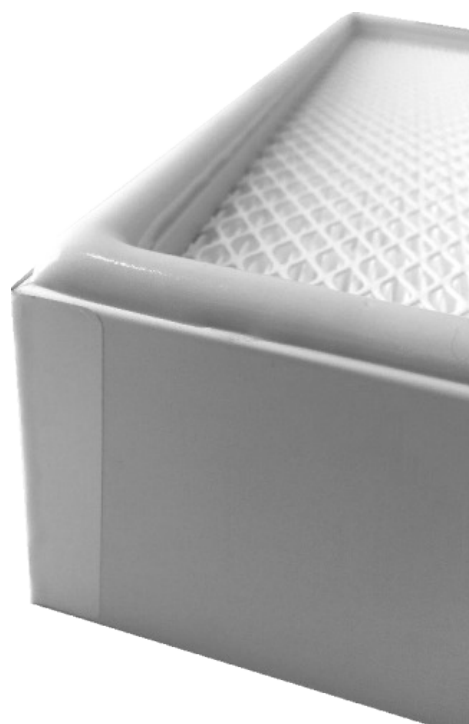

Filter with sealing detail

Dimensions and weight of box / filter

Horizontal position of the connecting sleeve

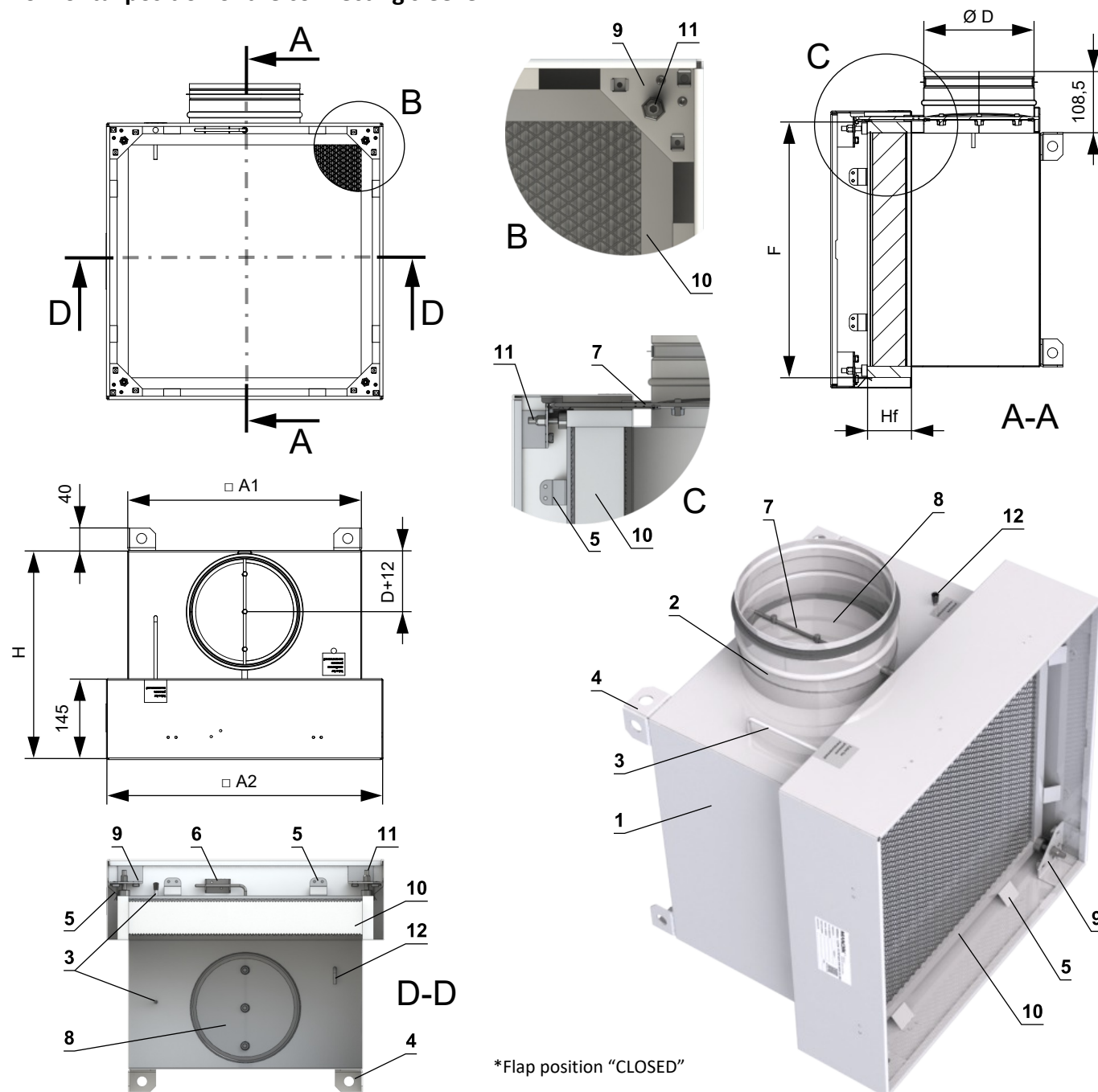

*Flap position "CLOSED"

- | | | | |
|---|---|----|--|
| 1 | Welded box | 7 | Flap axis / control levers |
| 2 | Connecting sleeve | 8 | Closing flap |
| 3 | Pressure measuring tube | 9 | Filter mounting bracket with tightening bolt |
| 4 | Hanging eyes | 10 | Frame filter with gasket (HEPA filter H14) |
| 5 | Centering leaf springs of the filter | 11 | Filter retaining adjusting bolt M8 |
| 6 | Flap lever stop (version with flap only)* | 12 | Tube for continuous pressure measurement |

Box size	A1 [mm]	A2 [mm]	Width of the filter frame F [mm]	D (DN) [mm]	H [mm]	Depth of the frame of the filter Hf (standard) [mm]	Weight of the box with the control flap - AISI 304 ^[1] [kg] (gross)	Weight of the standard filter [kg] (gross)
400/305	268	365	305	158 (DN 160)	335	34 ... 80 (69)	8,31	1,84
500/457	419	495	457	198 (DN 200)	375	34 ... 80 (69)	12,88	3,30
600/557	519	595	557	198 (DN 200)	375	34 ... 80 (69)	16,03	4,20
600/575	537	595	575	198 (DN 200)	375	34 ... 80 (69)	16,14	4,60
625/575	537	620	575	198 (DN 200)	375	34 ... 80 (69)	16,78	

^[1] Weights shown are without filter and front plate

Vertical position of the connecting sleeve

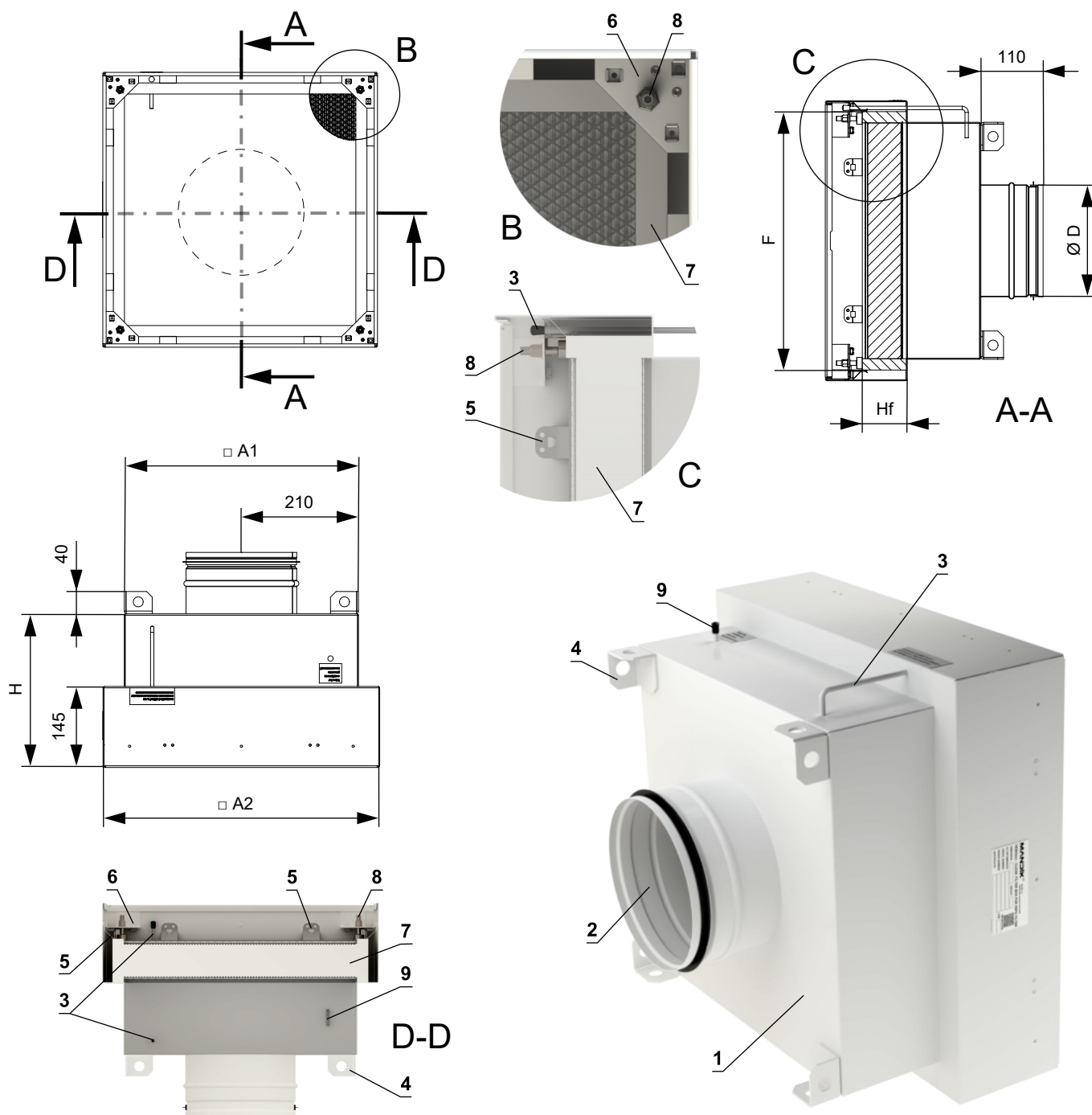

- 1 Welded box
- 2 Connecting sleeve
- 3 Pressure measuring tube
- 4 Hanging eyes
- 5 Centering leaf springs of the filter
- 6 Filter mounting bracket with tightening bolt
- 7 Frame filter with gasket (HEPA filter H14)
- 8 Filter retaining adjusting bolt M8
- 9 Tube for continuous pressure measurement

Box size	A1 [mm]	A2 [mm]	Width of the filter frame F [mm]	D (DN) [mm]	H [mm]	Depth of the frame of the filter Hf (standard) [mm]	Weight of the box - AISI 304 ¹ [kg] (gross)	Weight of the standard filter [kg] (gross)
400/305	268	365	305	158 (DN 160)	335	34 ... 80 (69)	8,11	1,84
500/457	419	495	457	198 (DN 200)	375	34 ... 80 (69)	12,48	3,30
600/557	519	595	557	198 (DN 200)	375	34 ... 80 (69)	15,63	4,20
600/575	537	595	575	198 (DN 200)	375	34 ... 80 (69)	15,74	4,60
625/575	537	620	575	198 (DN 200)	375	34 ... 80 (69)	16,38	

¹ Weights shown are without filter and front plate

Dimensions and weights of front panels and diffusers

VVPM front plate (fixed slats)

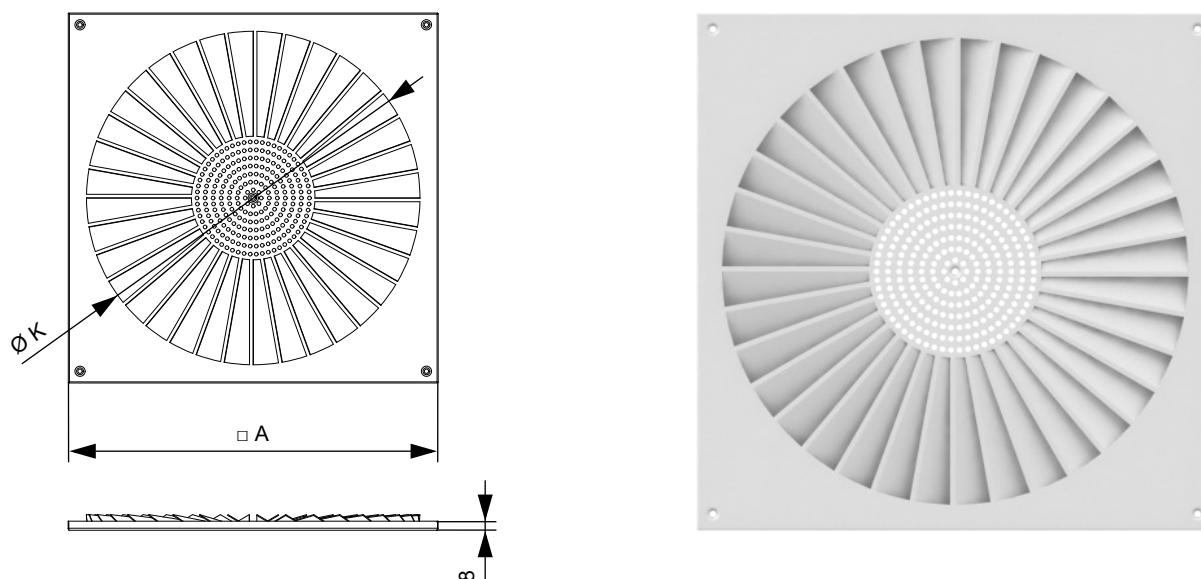

Box size	A [mm]	K [mm]	Weight of VVPM according to design [kg]		
			Aluminium	Carbon steel	Stainless steel AISI 304
400/...	399	170	0,38	1,10	1,12
500/...	499	270	0,71	2,06	2,11
600/...	599	370	0,80	2,34	2,40
625/...	624	390	0,87	2,53	2,60

Technical data for VVPM front plate are specified in the TPM 007/99

DVCM front plate (square/round)

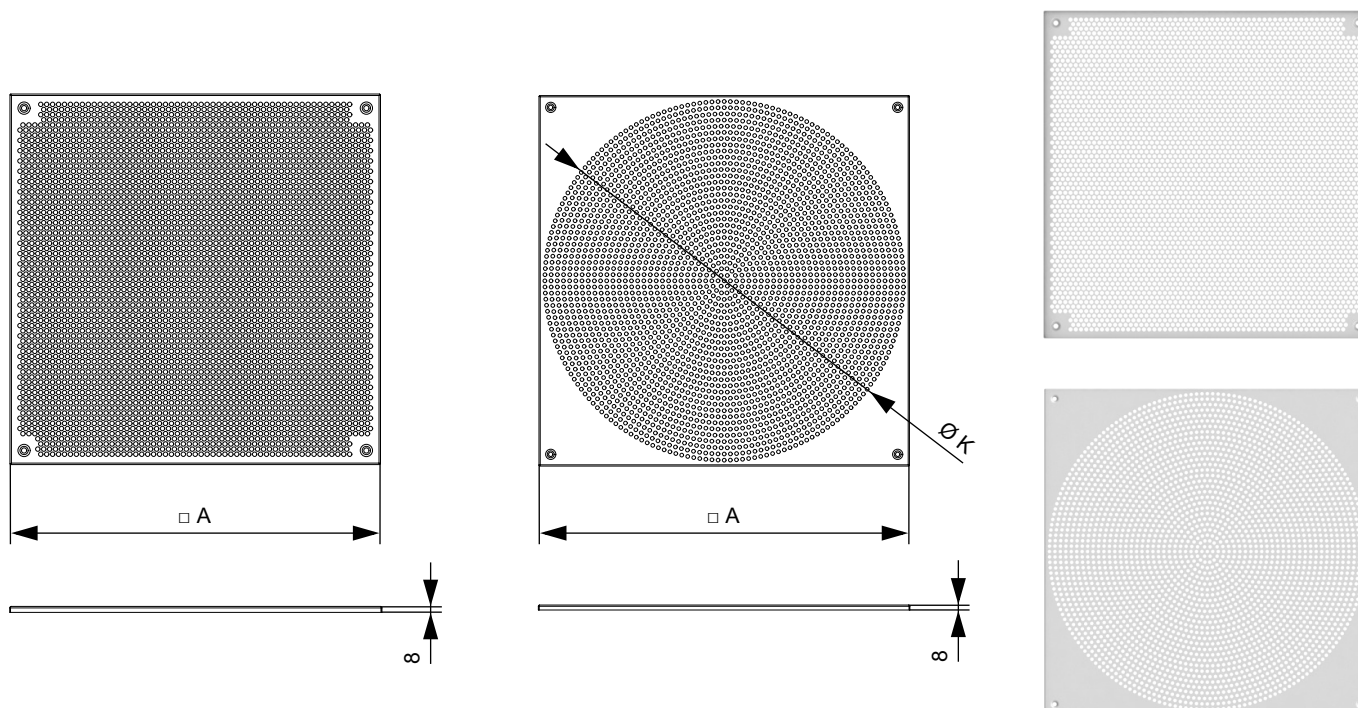

Box size	A [mm]	K [mm]	Weight of square DVCM [kg]	Weight of round DVCM [kg]
400/...	399	390	0,28	0,39
500/...	499	490	0,39	0,56
600/...	599	590	0,56	0,79
625/...	624	615	0,60	0,86

Technical data for DVCM front plate are specified in the TPM 131/17

VNM diffuser (adjustable slats)

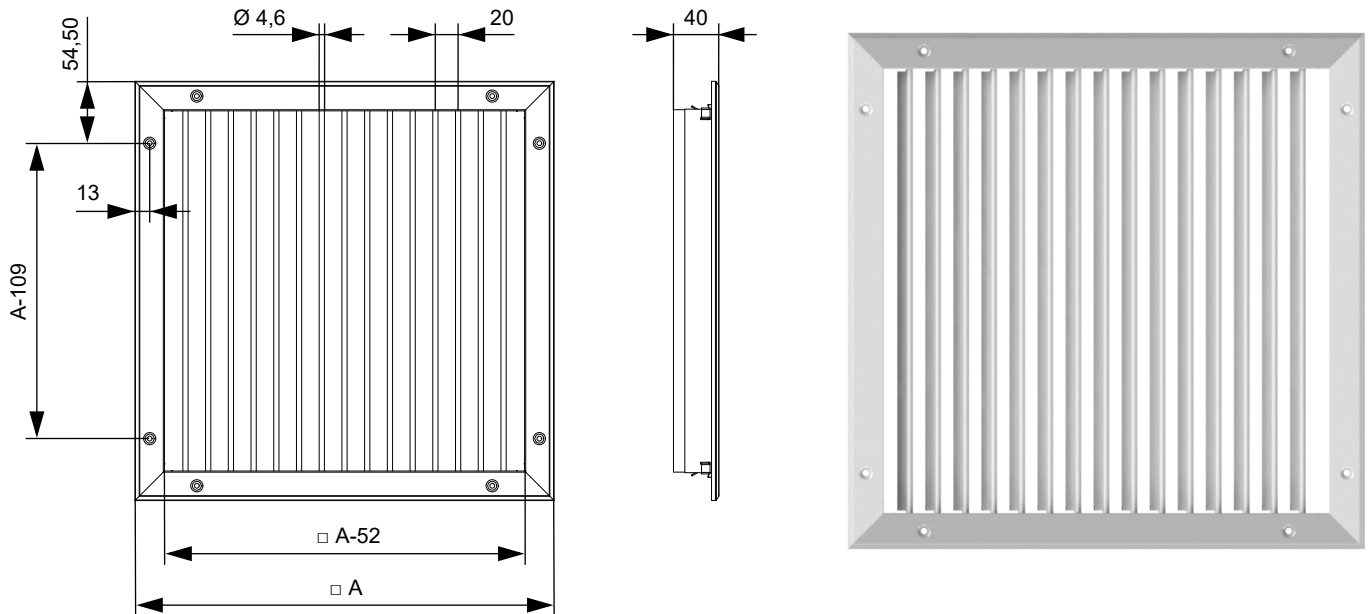

Box size	A [mm]	Weight [kg]
400/...	369	1,6
500/...	499	2
600/...	599	2,4
625/...	624	2,5

Technical data for VNM diffuser are specified in the TPM 015/01

RAG45 diffuser (slats in fixed position of 45°)

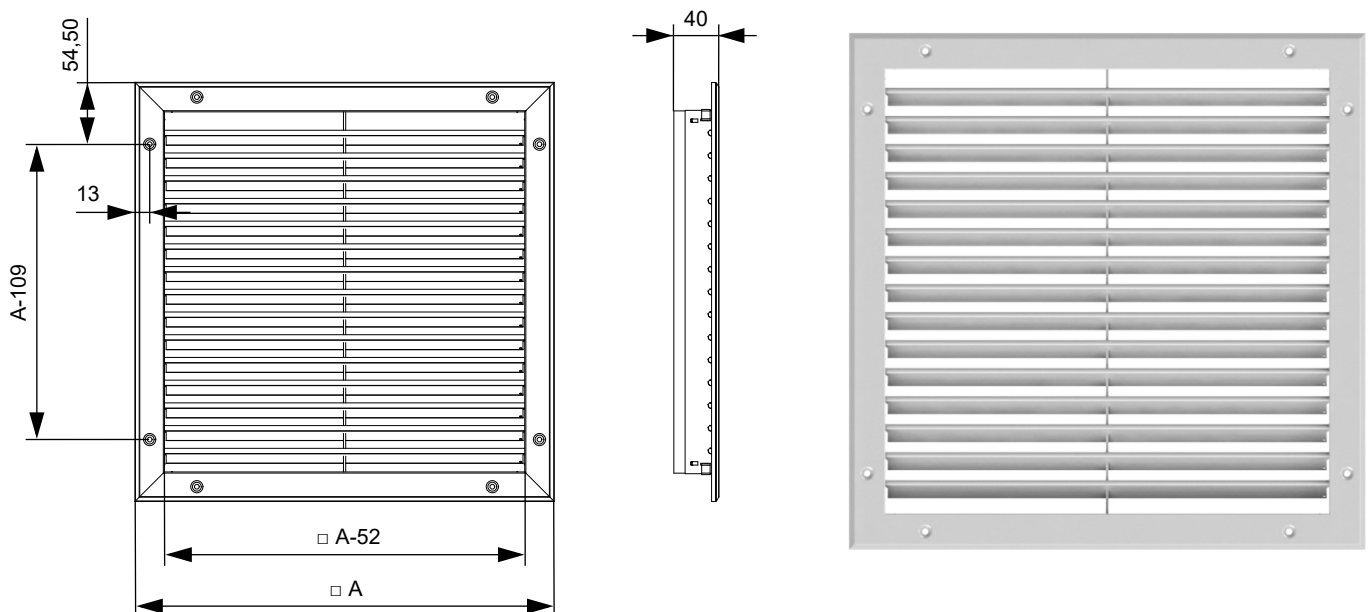

Box size	A [mm]	Weight [kg]
400/...	369	1,6
500/...	499	2
600/...	599	2,4
625/...	624	2,5

SMM wall grille (fixed slats - spacing 12,5mm or 20mm)

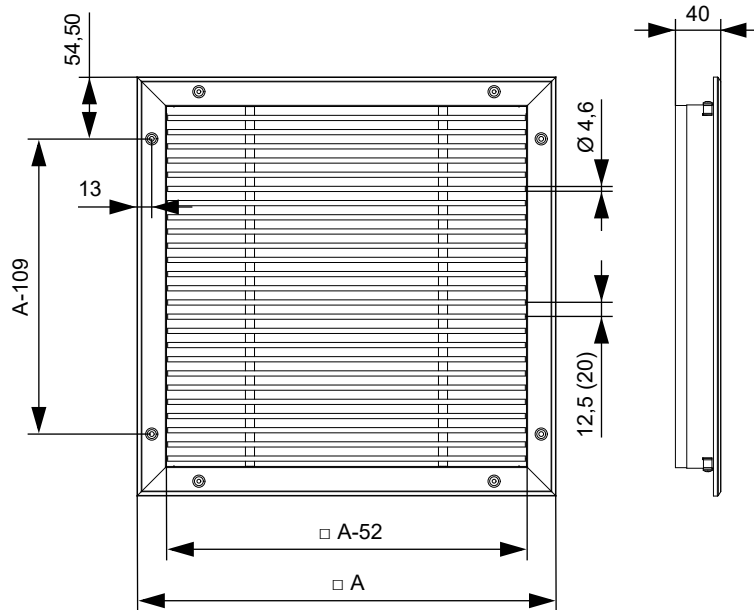

Slat spacing 12,5mm



Slat spacing 20mm

Box size	A [mm]	Weight slat spacing 12,5mm [kg]	Weight slat spacing 20mm [kg]
400/...	369	1,0	2,3
500/...	499	1,6	3,7
600/...	599	2,3	5,1
625/...	624	2,6	5,4

Technical data for SMM diffuser are specified in the TPM 014/01

Ceiling frames

- Frames help to adapt the dimensions of the plenum box to plasterboard ceilings, metal ceilings or T-bar ceilings.
 - Frames are made of stainless steel. The frame surfaces are painted with a special powder coating.
 - The size of the inner opening of the frame corresponds to the dimensions of the plenum box. The outer dimensions of the ceiling frame correspond to the size of the ceiling grid of 600 mm or 625 mm (for tin and cassette soffit T-ceilings) or exceed the inner opening by 50 mm (for plasterboard ceilings).
 - The frames can only be used for selected sizes of the plenum box in combination with the selected grid and type of suspended ceilings:
- HSC and HTC frames:**
- For a 600 raster, only 500 and 400 box sizes are possible
 - Only 600, 500 and 400 box sizes are possible for the 625 grid
 - Dimensions of the plenum box → see page 5
 - The frame is not part of the plenum box and is delivered loose in a cardboard package, including the connecting material.

HSC frame (light sheet metal ceiling frame)

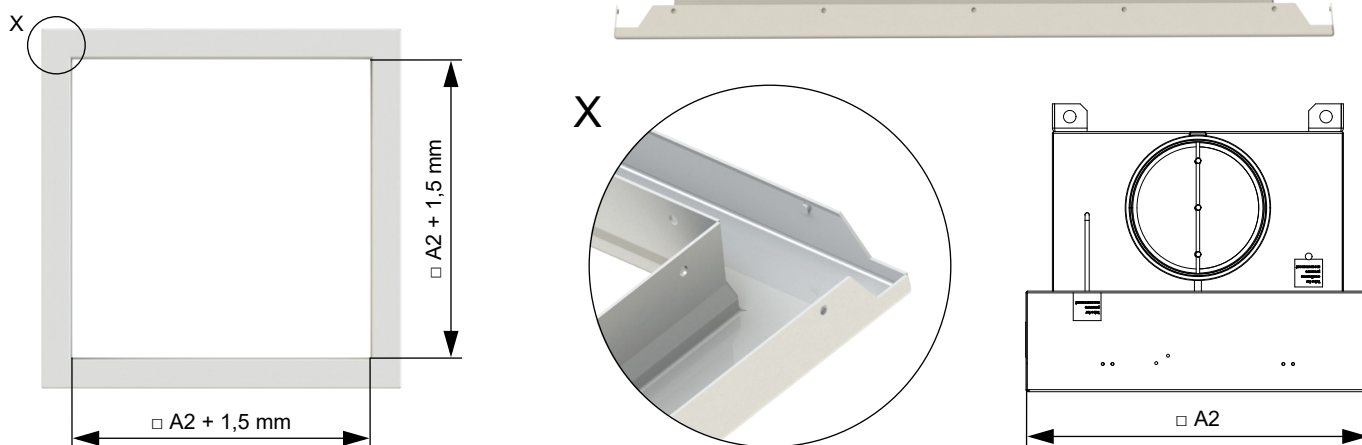

HTC frame (frame for cassette T-bar ceiling)

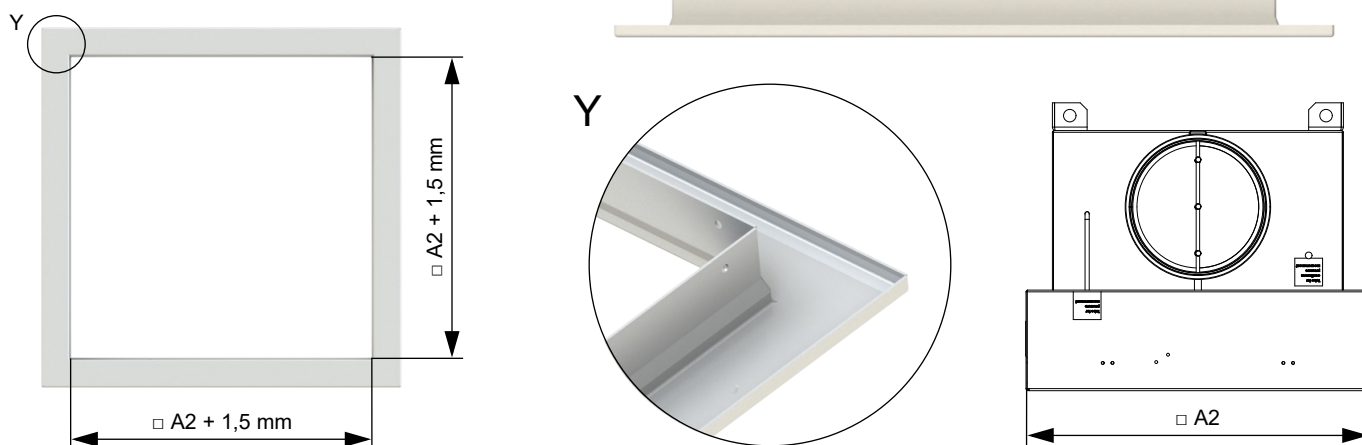

HGC frame (frame for plasterboard partition ceiling)

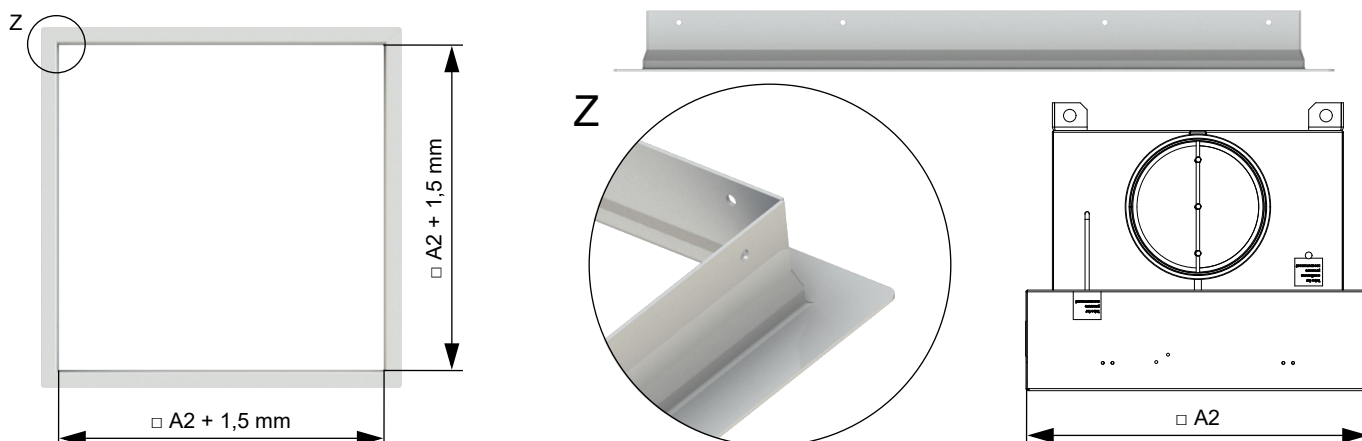

Materials and components

Used materials

- Individual parts of the box are made of the AISI 304 stainless steel and form the fully welded structure that is mechanically strong and, at the same time, airtight. On the box itself, the special powder coating of the RAL 9010 shade is then applied. On the connecting material, gaskets and the most moving components the coating is not applied. The connecting fittings and moving components, that are not powder-coated, are supplied as stainless AISI 304 parts.
- VVPM front panels may be delivered in AISI 304 stainless steel, mild steel or aluminum, painted with special powder paint in RAL 9010 color.
- DVCM front perforated panel is made of the aluminium metal sheet and powder-coated in the same manner.
- VNM, RAG45 and SMM diffusers are made of aluminium profiles protected with the anodized layer. They may also be coated with the antimicrobial powder paint of the RAL 9010 shade.
- Connecting material applied for the front plates and diffusers that is not possible to be powder-coated is made of the AISI 304 stainless steel.
- Neither front plates nor diffusers contain any plastic parts, elastomers, putty or glue.
- Plenum box itself can also be supplied in the economical variant as fully welded of the carbon steel metal sheet that is powder-coated using the same special powder paint. Connecting fittings and moving components, that are not powder-coated, are supplied as AISI 304 stainless steel parts.

HEPA filters

- Filters making part of the standard delivery package are top HEPA filters of AAF brand conforming to H14 filtration class. They consist of the anodized aluminum frame, integral PUR foam with closed pores and closed surface foamed directly to the filter frame profile (mechanical bond), glass filtration media and a fine protection grid from painted steel from the both faces.
- All materials correspond to sanitary standards.

Chart of filters that are supplied as the standard (frame square FxF depths Hf)

Filter type designation	Filter frame width F [mm]	Filter frame depth Hf [mm]	Functional designation of the manufacturer AFF
N365-H14-AL-305x078	305	69	ASTROCEL II A99C9S2R3 305x305x69mm
N365-H14-AL-457x078	457	69	ASTROCEL II A99C9S2R3 457x457x69mm
N365-H14-AL-557x078	557	69	ASTROCEL II A99C9S2R3 557x557x69mm
N365-H14-AL-575x078	575	69	ASTROCEL II A99C9S2R3 575x575x69mm

II. TECHNICAL DATA

Pressure drop

Air flow rate, pressure drop

Nominal air flow, pressure drop, maximum overpressure in the main chamber											
Box size	Nominal air flow q_{Vnom} [1]		Initial pressure drop Δp_{Vnom} of HEPABox with standard H14 HEPA filter, without flap at nominal flow rate q_{Vnom} [Pa] [2]							Flap pressure drop at q_{Vnom} [Pa]	Maximum overpressure in the main chamber [3] [Pa]
	[m ³ /h]	[l/s]	without front plate	with VVPM	with DVCM square	with DVCM round	with VNM, SMM 20	with SMM 12	with RAG45		
400/305	200	56	144	161	152	158	148	164	152	2	500
500/457	450	125	152	169	161	167	156	172	160	2	
600/557	670	186	167	183	175	181	171	187	174	4	
600/575	720	200	171	187	179	185	175	191	178	5	
625/575	720	200	171	187	179	185	175	191	178	5	

[1] Standard air density of 1,2 kg/m³ considered.

[2] Measured as difference between the static pressure in the duct entering the HEPABox, and the room pressure.

[3] Measured with help of built-in measuring tube as difference between the static pressure inside the main chambre and the room static pressure. This maximum overpressure is reached at end pressure drop of the standard delivered filter.

Maximum airflow for different front plates and without front plates															
Box size	Maximum air flow q_{Vmax} *														
	without front plate			with VVPM			with DVCM square			with DVCM round			with VNM, with RAG 45, with SMM		
	[m ³ /h]	[l/s]	q_{Vmax}/q_{Vnom}	[m ³ /h]	[l/s]	q_{Vmax}/q_{Vnom}	[m ³ /h]	[l/s]	q_{Vmax}/q_{Vnom}	[m ³ /h]	[l/s]	q_{Vmax}/q_{Vnom}	[m ³ /h]	[l/s]	q_{Vmax}/q_{Vnom}
400/305	400	111	2	200	56	1	250	69	1,25	200	56	1	400	111	2
500/457	900	250	2	450	125	1	563	156	1,25	450	125	1	900	250	2
600/557	1340	372	2	670	186	1	838	233	1,25	670	186	1	1340	372	2
600/575	1440	400	2	720	200	1	900	250	1,25	720	200	1	1440	400	2
625/575	1440	400	2	720	200	1	900	250	1,25	720	200	1	1440	400	2

* Measured as difference between the static pressure in the duct entering the HEPABox, and the room pressure.

Pressure drop of a HEPABox without a flap with a standard H14 class filter depending on air flow

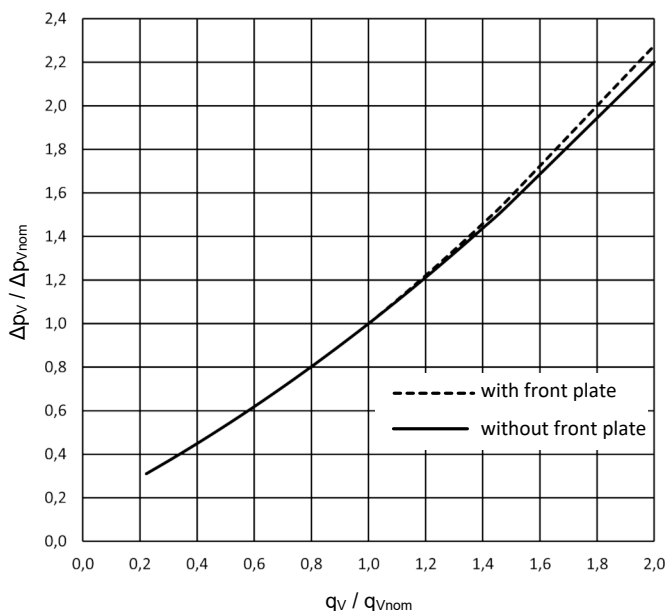

Pressure drop of flap as depending on air flow

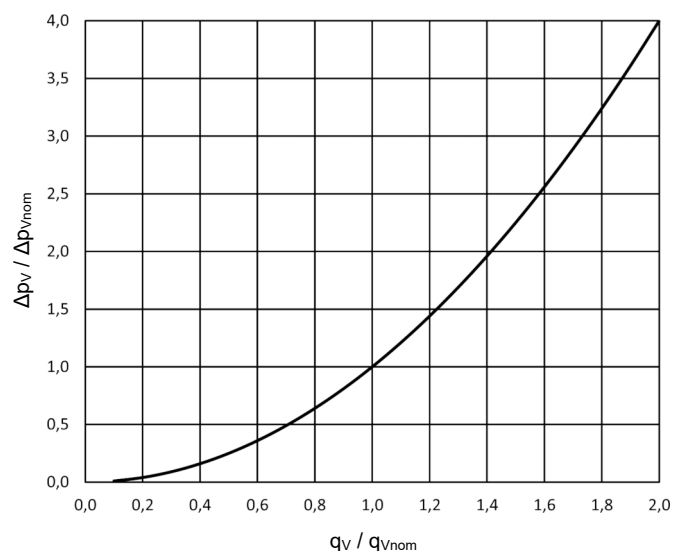

Acoustic data

Acoustic output affected by filter A - box without front plate

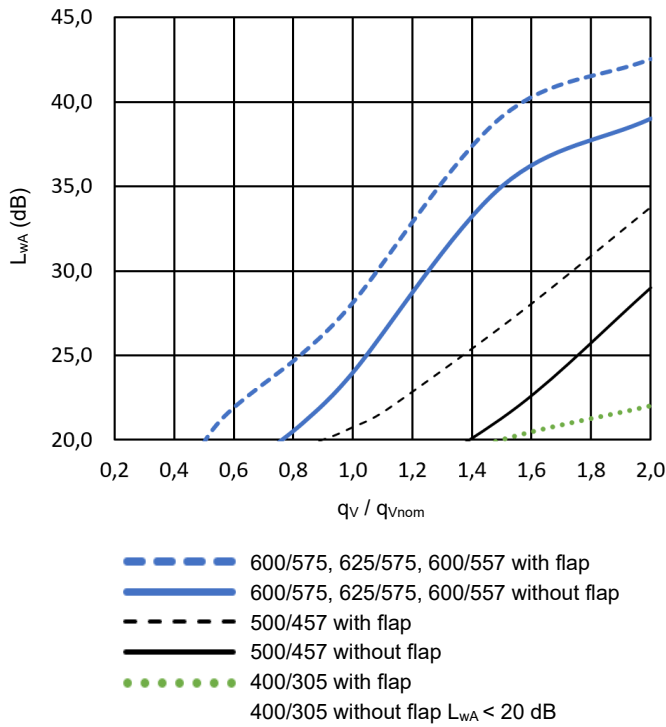

Acoustic output affected by filter A - box with VVPM
Applies both for box fitted with flap and without flap

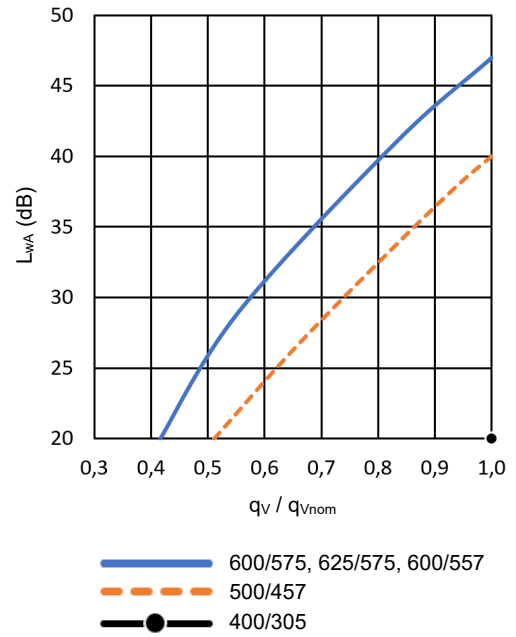

Acoustic output affected by filter A - box with DVCM square

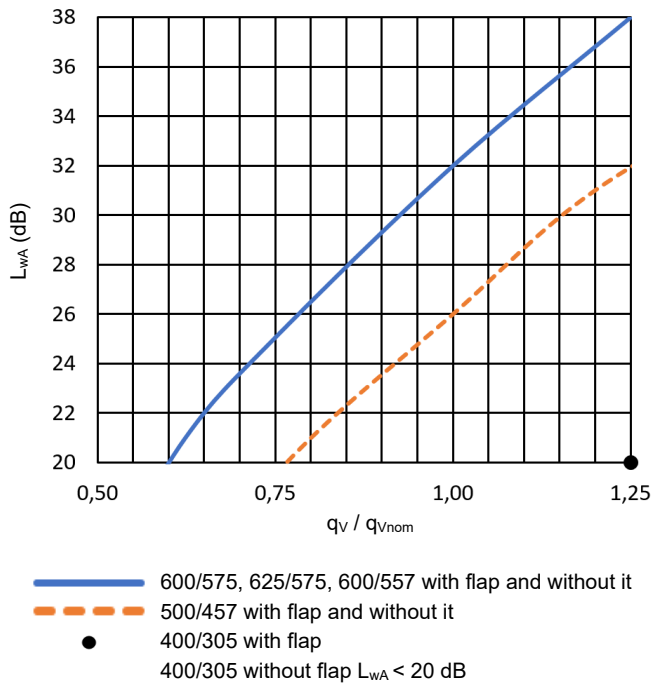

Acoustic output affected by filter A - box with DVCM round
Applies both for box fitted with flap and without flap

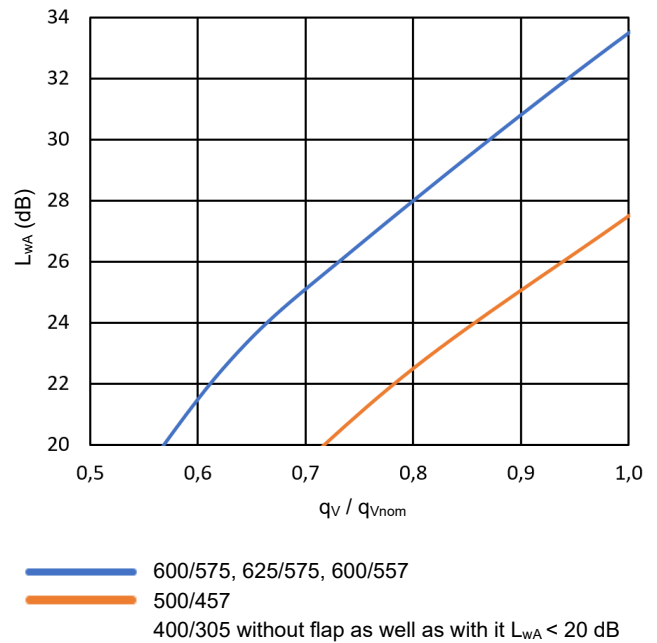

Acoustic output affected by filter A - **box with VNM, SMM or RAG45**

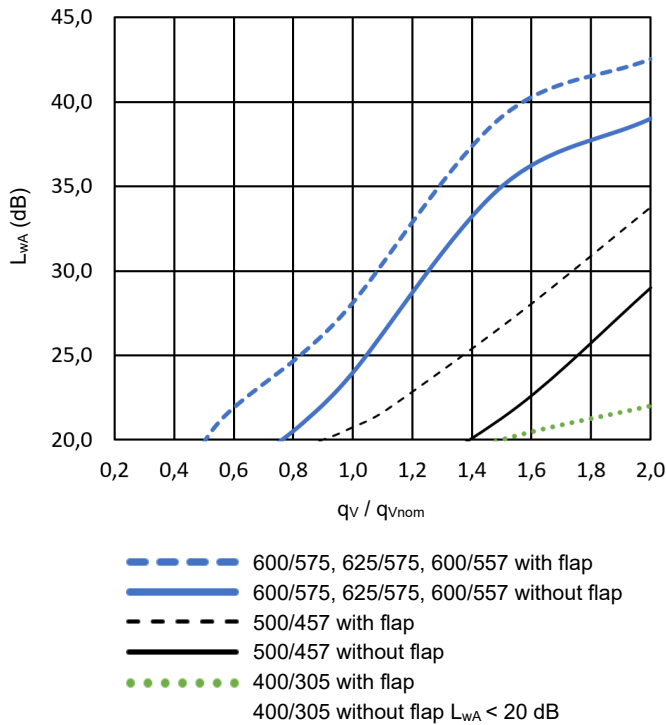

III. INSTALLATION, OPERATION, MAINTENANCE

Installation and commissioning

The project of the HVAC system and its physical realization shall assure that:

- pressure in HEPAbox main chambre and the air flow rates will not exceed maximum values presented in this technical document
 - quality of the supply air corresponds to the requirements for HEPA filtration step, including multi-step preliminary filtration, prevention of the entry of liquid water, droplets or fog into the box, and also the prevention of condensation – all surface temperatures shall be kept superior to the dew point of the air with sufficient safety margin.
- a) As the first step, installation of hanging elements and of the supply air duct is recommended.
 - b) Installation of HEPAbox should be preferably after finalization of all construction works and dusty operations in order to prevent the contamination or even damage of the product.
 - c) Box is, as a standard part of the delivery, supplied in 2 cardboard boxes; one contains box itself with the front plate while the other one contains the HEPA filter (optionally, based on the customer’s requirement).
 - d) First, plenum box itself is to be installed. When doing that, make sure that you do not open the box with the filter; box with plenum box should only be opened immediately before commencing the installation work.
 - e) Prior to commencing the installation of plenum box itself, it must be checked that it is clean (by means of a simple visual inspection) by a qualified personnel possessing at least Class A qualification as per VDI 6022 Part 4. When doing that, the front plate is to be removed from plenum box and temporarily placed back in the plastic bag and box.
 - f) Suspension of plenum box, its connection to the air duct or, as the case may be, its embedding in the ceiling cassette should be done using the common procedures so that the suspension is safe, the joint keeps the given tightness class permanently and that no significant contamination of or damage to the product occurs. It is especially necessary to pay attention that the surface of plenum box (the inner flange) on which the gasket of the filter is to rest gets not damaged.
 - g) Installation of plenum box itself is to be performed while the air-handling systems are off (the air neither flows into the unit nor is being sucked out of the room). When doing that, one should take care that the room is sealed from the surrounding premises, if any risk of mutual contamination is present. If plenum box is fitted with the entrance closing flap, it is necessary, after the installation of plenum box, to close the entrance closing flap or verify, by

visually checking the control lever, that the flap is closed. Furthermore, it is necessary to check that the front tube of the probe is blinded and that the side tube of the probe is either blinded or tightly connected to the static pressure sensor.

- h) Prior to performing the installation of the filter, the room and plenum box itself must be cleaned and disinfected. Especially the surface on which the filter gasket should rest must be free of any contamination – otherwise, there is a risk that the filter loses its tightness and, subsequently, its efficiency. When performing the cleaning and disinfection process, proceed according to the section „Cleaning and disinfection“.
- i) If plenum box is fitted with closing flap, it is necessary to verify that the flap is closed by verifying that the control lever is in the “closed” position.
- j) Immediately prior to commencing the installation of the filter, take the filter out of the box and plastic bag. Visually check the filter and place it in plenum box so that the gasket is oriented towards the inside of plenum box (i.e. gasket is oriented upwards - this applies the suspended plenum box). The filter will be retained in the position by leaf springs that are built-in from the side. Into the corners, insert filter mounting bracket with tightening bolt. Finely tighten the bolts one by one – firstly on one diagonal, then on the other one – until you can feel the counter-pressure generated by the compressed gasket. Then, finish the tightening of the individual bolts so that the torque as per [the chart](#), below is achieved.
- k) It is unconditionally necessary that you handle the filter with utmost care, so that it does not get damaged.
- l) Before installing the front plate, perform the check of the integrity of the filter and of the tightness of the clean extension by means of the oil mist; to do that, use the tube of the probe from the front side of plenum box. After finishing the test, the tube must be blinded again. Then, other, if any, required inspection operations should be performed; afterwards, the respective record is to be made.
- m) Put front plate on and secure it with the supplied bolts. If the front plate allows for it, set the blades of the front plate so that the air flow to the room corresponds to the requirements. Then, other, if any, required inspection operations should be performed; afterwards, the respective record is to be made. It is not recommended to use other front plates or bolts than those supplied with HEPAbox in order, to guarantee that plenum box assembly is completed in a hygienic manner and also to ensure that the design of the front plates corresponds to the air flow range that flows through plenum box. We especially recommend to avoid the application of non-approved coatings and non-metallic elements such as elastomer and foam sealing or plastic blades and covers; also, any materials that are not compatible with used cleaning and disinfecting agents and methods must be avoided as well.

Torque and compression of gasket of filter				
Filter size [mm]	min Nm	max Nm	Compression of gasket of filter [mm]	Compression of gasket of filter [number of rotation]
305x305	1,6	2,5	3	2,5
457x457	2,2	3		
557x557	2,8	3,5		
575x575	2,8	3,6		

Installation of frames in the ceiling structure

Mounting frame installation procedure

- 1) Hang plenum box into the structure of the building (concrete ceiling).
- 2) Place the frame on a plenum box and fasten rivets (4x8mm) in the prepared holes, around the entire perimeter and fill the resulting joint.
- 3) Place the plenum box with the frame in the grid, according to the type of ceiling.

Without frame (for plasterboard partition ceiling)

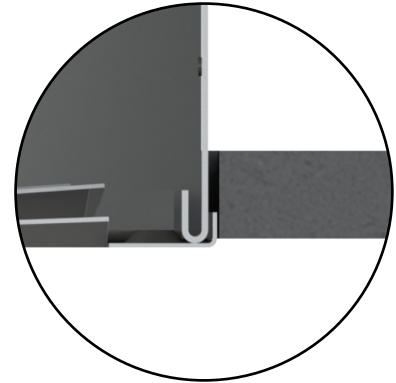
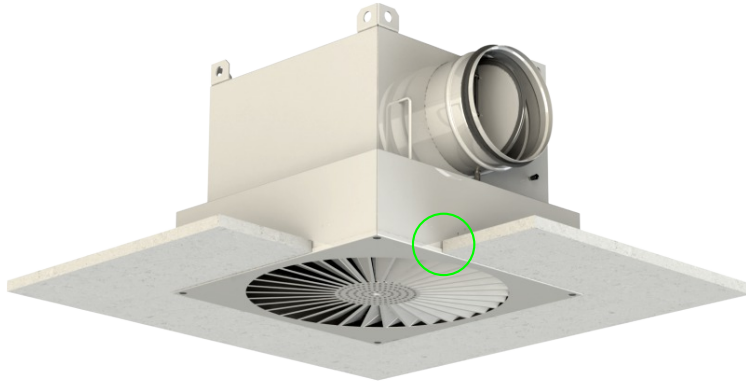

HGC frame (frame for plasterboard partition ceiling)

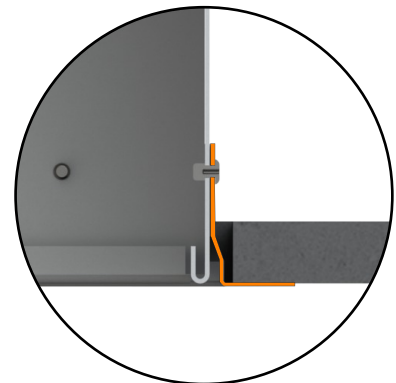
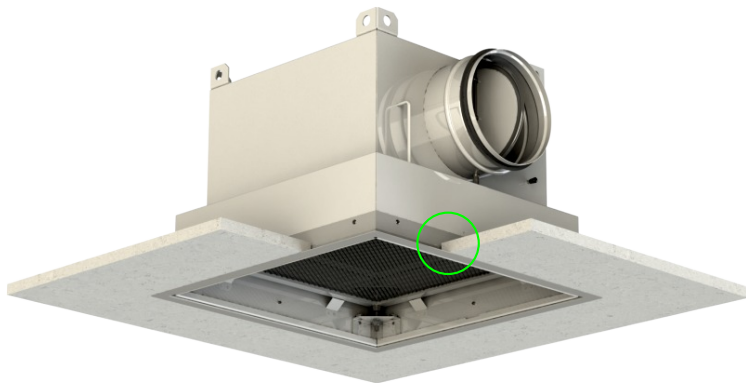

HSC frame (light sheet metal ceiling frame)

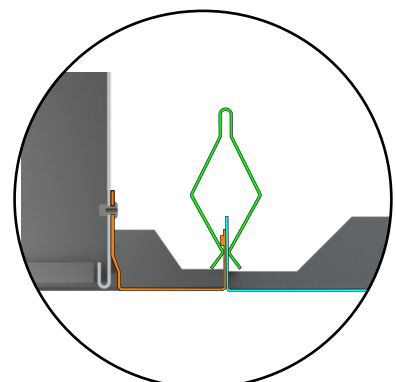
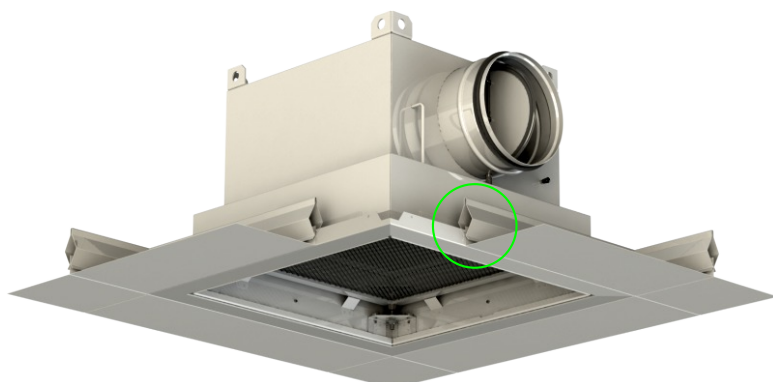

HTC frame (frame for cassette T-bar ceiling)

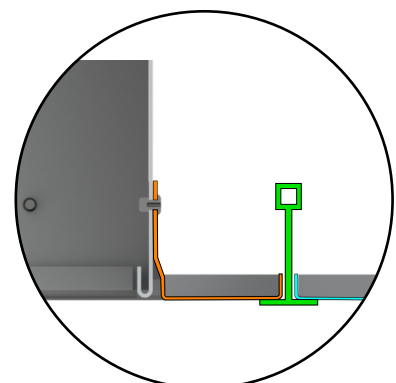
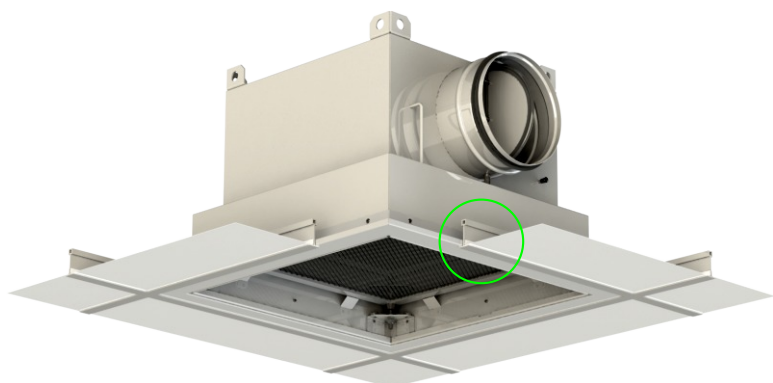

Operation and maintenance

- a) Although the box is made from materials demonstrably resistant to microbes, surfaces of the unit shall be cleaned and disinfected on regular basis; the interval being determined as per the intensity of contamination processes, environmental conditions as the temperature and humidity, requirements on the cleanliness of the room, applicable regulations and the best practice. Cleaning and disinfection shall be carried out in accordance with chapter „Cleaning and disinfection“.
- b) The rate of the filter clogging should be checked either on regular, or on continuous basis. Filter end pressured drop expressed by the pressure in the main chambre (500 Pa for standard delivered filters) may be measured using one of the two pressure measuring tubes integrated (welded) into the box.
- These are:
- one tube from the front, accessible simply after removal of the front panel (for regular checks)
 - one tube from the side, facing into the under-floor space (for continuous, automated checking)
- Measured overpressure should not exceed 500 Pa. The measurement procedure shall guarantee that there will be no resulting contamination (static – membrane sensors, closing the flap or switching off the air flow when the measuring tube will be open to the room, then, the air flow to the plenum box only after the sensors will be conneted).
- c) Even if 500 Pa limit (or any other pressure limit given by the filter’s manufacturer) is not reached, it is necessary to change filters on regular basis as a prevention, the interval being determined as per the intensity of contamination processes, environmental conditions as the temperature and humidity, requirements on the cleanliness of the room, applicable regulations and the best practice. Although the standard allows to change filters in some cases only once per 7 years, as a precaution, we recommend to change the filter at least once per 4 years.

Filter Replacement

- a) When replacing filter, it is necessary to prevent any risk to the health of persons and keep any contamination to a minimum level possible.
- Proceed as following steps:
- 1) interrupt any normal activity in the area, transport the patients from, or let them walk out of, the area, transport any sensitive devices and materials out of the area as well, close the area.
 - 2) prevent any air from entering the unit by turning the ventilator off and/or by closing the air-handling flap (being of the tightness over the blade of the flap of class 4 as per EN 1751).
 - 3) remove the front panel / grille
 - 4) remove filter and place it into the plastic bag that you prepare in advance, airtight close the bag
 - 5) clean and disinfect the area
 - 6) clean and disinfect whole box, including the inside and front plate from both sides
 - 7) install the new filter and test it in the box as per the chapter „Installation and commissioning“
 - 8) install the front plate.
- The personnel performing the replacement of the filters should possess the required skills and should be equipped with corresponding personal protective equipment (protective clothes, gloves, mask, respirator). The used filters must be disposed of while complying with all the relevant sanitary and environmental regulations.
- b) It is necessary to replace the filter after any incident or accident that could cause contamination or even damage to the filter or plenum box (such as rupturing of the filter of the upstream filtration stage, technological accident or fire in the room, contamination with the biological material, etc.).

Cleaning and disinfection

- a) Cleaning and disinfection agents shall be used systematically in a manner that eliminates health hazards. First of all instructions for use shall be respected and protective clothing and gloves shall be used.
- b) For the disinfection, only agents applied to the surface shall be used.
- c) Effective cleaning and disinfection is as following steps:
- 1) mechanical removal of coarse dirt (if any) using the soft brushes or cloth as organic impurities generally reduce the effect of disinfectants
 - 2) wiping or rinsing with warm drinking water
 - 3) Cleaning (sanitation) application of the cleaning solution according to the manufacturer's instructions given on the product label (observance: concentrations, pH of water, exposure times, temperatures). Without sufficient sanitation, microorganism are protected by impurities (biofilms are formed etc.) and disinfectants cannot act sufficiently. Removes inorganic and organic substances, reduces the initial number of microbes.
 - 4) Rinsing with warm soft, biologically harmless water removal of residual dirt and detergents
 - 5) visual inspection of cleanliness
 - 6) Disinfection application of the disinfectant solution according to the manufacturer's instructions given on the product label. More recommendations follow.
 - 7) final rinsing with drinking water removal of disinfectants from the surface
 - 8) drying preferably spontaneous drying by evaporation to dryness
 - 9) ensuring the right conditions for storage and disposal of the waste.
- d) Following factors have particular effect on the effectiveness of disinfection:
- tightness of the contact of the disinfectant with the surface – the tighter the contact, the shorter the disinfection time and stronger the effect
 - sufficient temperature of the solution – in general, higher temperature gives stronger disinfection effect, but pay attention to work safety and the possibility of the disintegration of some disinfectants
 - concentration – in general, higher concentration gives stronger disinfection effect, low concentration is ineffective, but pay attention, too high concentration leads to damage of the material being disinfected
 - exact exposure time – fundamental influence on the final effect of the disinfection
 - pH of water – many products work well only within certain pH range.
- e) For effective disinfection, it is recommended to alternate or combine disinfectants. Some disinfectants have a partial cleaning effect (surfactant character) and the ability to penetrate the dirt, so they can be used as combined cleaning and disinfecting agent. It is advisable not to buy disinfectants in large quantities, to ask the seller for comprehensive documentation that meets the requirements of local laws and regulations.
- f) HEPA filter delivered with HEPAbox as a part of the standard delivery package contains only microbiologically inert materials and protective coatings:
- glass fiber filtration media
 - anodized aluminum frame
 - filtration media sealing
 - gasket from integral PUR foam directly foamed into the frame profile (purely mechanical joint, no adhesive used).
- g) The box itself contains only metals, or microbiologically tested non-metallic materials (tested in accordance with ISO 846 method A (resistance against yeasts) and C (resistance against bacteria):
- polyester powder paint with inorganic additives
 - major gaskets from EPDM rubber, minor gaskets from NBR rubber.
- h) Although the box is manufactured from biologically inert materials only, cleaning and disinfection shall not be neglected, as the growth of microbes may be possible just by the impurities (dirt), representing a nutrition source, source of water, or otherwise negatively influence physical-chemical or mechanical state of the surface.
- i) Cleaning and disinfection agents being used shall not leave the surface or micropores with deposits that would be hydrophilic or otherwise negatively influence the state of the surface. Also, cleaning and disinfection agents being used shall not attack the surface of the material directly or leave deposits that would attack the materials.
- Therefore, the disinfection agents used shall meet the following criteria:
- alcohol free, chlorine free, aldehyde free, formaldehyde free
 - never use corrosive or abrasive substances
 - never use strong acids or bases (optimal pH range 6–8)
- j) Cleaning and disinfection agents may only be used by competent personnel (persons with adequate qualification, training and credentials).
- k) Do not use abrasive powders, pastes, papers, washcloths or other materials or means that could damage the surface of the paint.
- l) Cleaning and disinfection agents used should be tested by Verbund für Angewandte Hygiene e.V. (VAH); the list of agents may be found on <https://vah-liste.mhp-verlag.de/>
- m) The following product are recommended:
- **Descosept Spezial**, Dr. Shumacher GmbH, bactericidal; active ingredient: quaternary ammonium
 - **Sanosil**, SANOSIL AG, bactericidal, fungicidal; active ingredient: hydrogen peroxide

- **RHEOSEPT-WD plus**, NW-Chemie GmbH, bactericidal, fungicidal, viricidal; active ingredient: quaternary ammonium
 - **RHEOSEPT-WD plus Wipes**, NW-Chemie GmbH, bactericidal, yesticidal; active ingredients: quaternary ammonium, alkylamine derivative
 - **Hexaquart pure**, Braun Medical AG, bactericidal, fungicidal; active ingredient: quaternary ammonium.
- n) Under normal operating conditions, regular cleaning and disinfection concerns only the external face of the front panel, fins or blades of the outlet grille. Following an interruption of the HVAC system for more than 48 hours, removal of the front panel is recommended, followed by the cleaning and disinfection of the inner parts of the front panel / outlet grille.
- o) The box is to be cleaned from the inside only in connection with the filter change. Should a necessity of the cleaning and disinfection from the inside of the box occur for some reason (e.g. a failure of a filter of the supply AHU and resulting duct contamination), the HEPA filter must be replaced!

Ecologic liquidation

HEPA filter

- Used filters must be disposed of while complying with all the relevant sanitary and environmental regulations. If the disposal process allows for it, the aluminium frame of the filter can be used as the secondary raw material.

Plenum box

- Plenum box itself will be serving well for many years. At the end of the life cycle, the unit can be treated, after cleaning and disinfection, as the secondary raw material; up to 99% of the materials of the unit are recyclable; it is especially steel.

IV. PACKAGING, TRANSPORT, STORAGE, WARRANTY

Logistic data

- Plenum boxes are packed individually into the hygienic plastic bags and then placed into the cardboard packaging. HEPA filter is packed separately using the same method. For the purposes of transport, the both cardboard packages are pulled together with the tape. They are transported freely laid in covered vehicles. Upon agreement with the customer the cabinets can be transported on pallets. When handling during transport and storage, cabinets must be protected against mechanical damage.
- Do not open the cardboard boxes, do not open the plastic bags to avoid damage or contamination. The cardboard boxes and plastic bags should be opened immediately before the installation.
- The boxes are only inspected from the outside, whether they are not mechanically damaged or damaged by dampness or another kind of liquid substance.
- If no other acceptance procedure agreed, the goods is considered accepted by customer by its handover to the forwarder.
- HEPAbox and HEPA filters shall be stored in the original packaging, in covered spaces at absence of aggressive vapors, gases, dust and direct sunlight. The temperature shall be maintained in the range of +5 to +40°C, and the relative humidity max. 80%.

Warranty

- The warranty period of 24 month applies.
- Should the product be used for other purpose than intended, instructions described in this technical documentation not respected, or the should the product be mechanically damaged, the warranty will not apply.
- Any transportation damage should be recorder for eventual further damage compensations.

V. ORDERING INFORMATION

Ordering key - HEPAbox

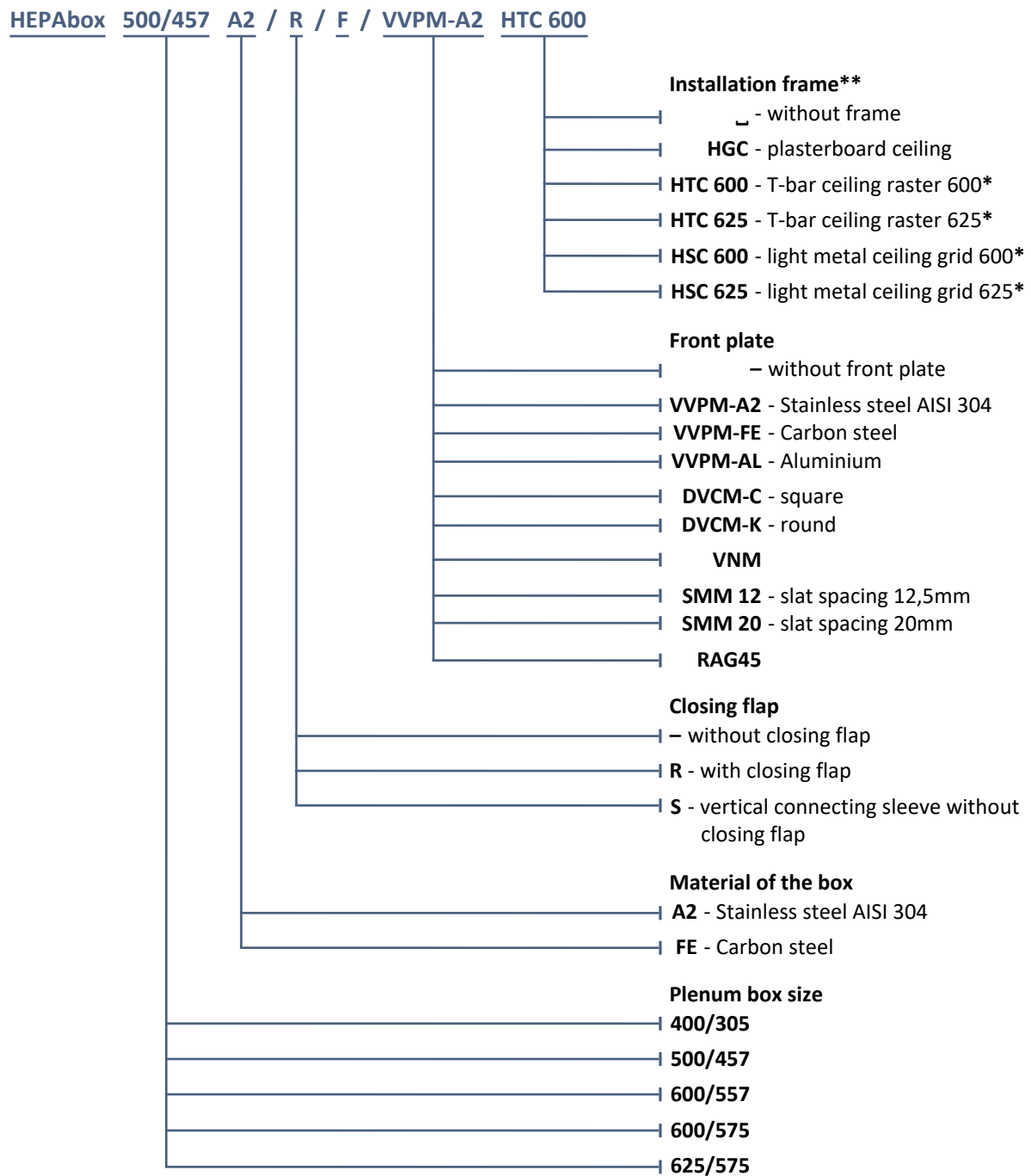

* For a 600 grid, only 500 and 400 box sizes are possible.
 For a 625 raster, only 600, 500 and 400 box sizes are possible.

** The installation frame is not part of the plenum box and is delivered loose in a cardboard package, including connecting material (12x rivets 4x8mm).

EXAMPLE:

HEPAbox 500/457 A2/R/F/VVPM-A2 HTC 600 - 500/457-plenum box size, A2-stainless steel AISI 304 material of the box, R-with closing flap, VVPM-A2-stainless steel AISI 304 front plate, HTC 600-installation frame

Ordering key - accessories

Front plate

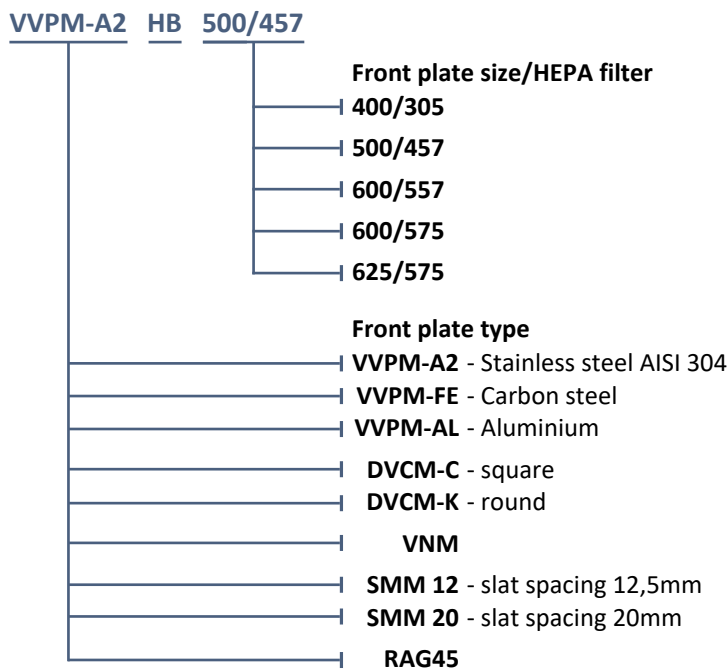

HEPA filter

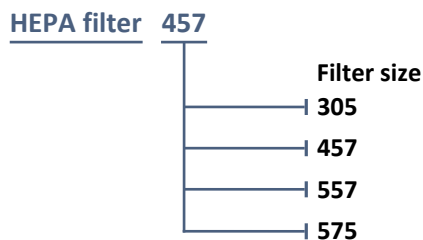

Installation frame

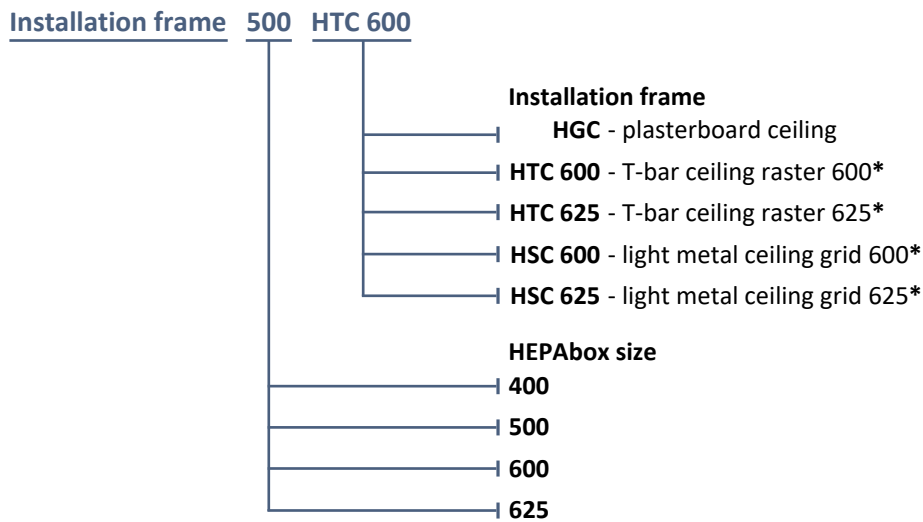

* For a 600 grid, only 500 and 400 box sizes are possible.
 For a 625 raster, only 600, 500 and 400 box sizes are possible.

VI. PRODUCT INFORMATION

Data label

- The data label is attached to the plenum box body (example)

MANDÍK [®]		MANDÍK, a.s. Dobříšská 550, 267 24 Hostomice, Czech Republic		
HEPAbox - plenum box for cleanrooms				
DIMENSION:	<input type="text"/>	WEIGHT (kg):	<input type="text"/>	 MANUAL
FILTER SIZE:	<input type="text"/>			
SERIAL NUMBER:	<input type="text"/>			
ORDER NUMBER:	<input type="text"/>		TPM 154/22	
PROTOCOL NUMBER: W-355575-22-Zd, certificate issued on 28.4.2022				

The producer reserves the right for innovations of the product.
For actual product information see www.mandik.com

MANDÍK[®]
www.mandik.com

