

## Installation frame E5

FDMB

### Installation manual

Installation in gypsum wall under flexible ceiling

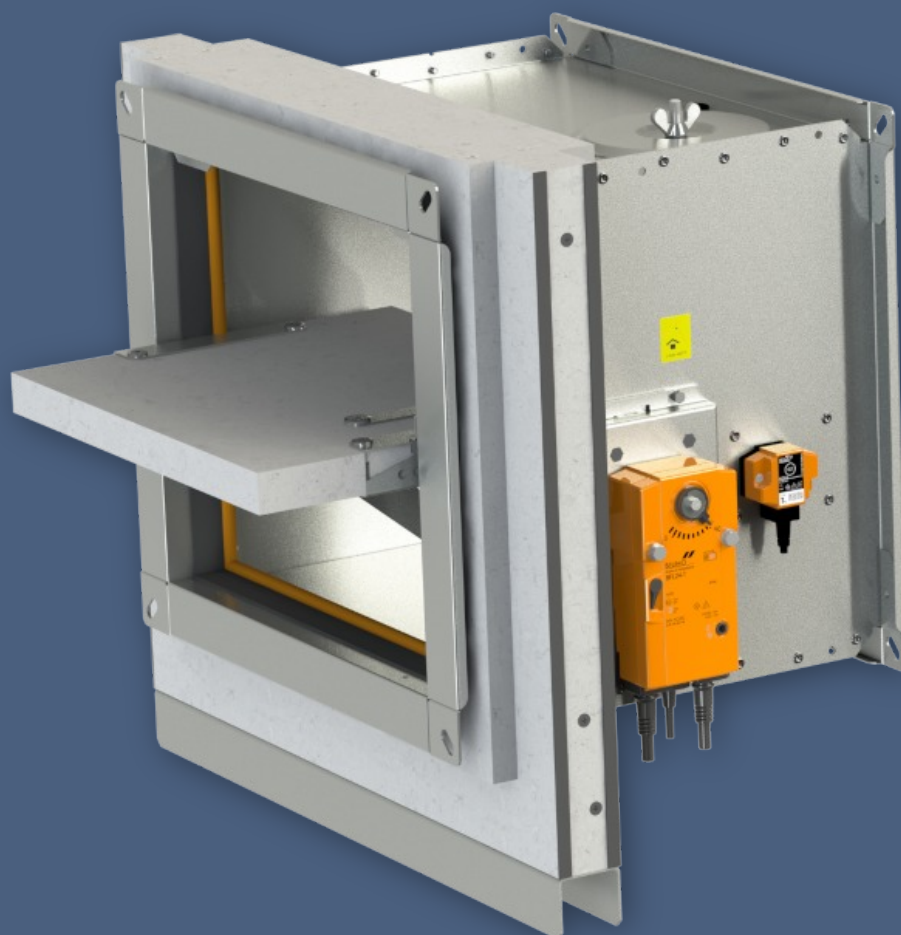

# CONTENT

- I. GENERAL.....3
  - Frame dimensions.....3
- II. INSTALLATION.....4
  - Description.....4
  - Wall preparation.....4
    - Installation directly on the ceiling.....4
    - Installation at a maximum distance of 80 mm from the ceiling.....5
  - Finishing the walls.....5
    - Installation frame E5 - wall thickness 100 mm.....6
    - Installation frame E5 - wall thickness  $\geq 115$  mm.....7
    - Rules of finishing the walls.....9
  - Fixing the installation frame to the ceiling.....10

# I. GENERAL

## Frame dimensions

### Installation frame E5 for FDMB

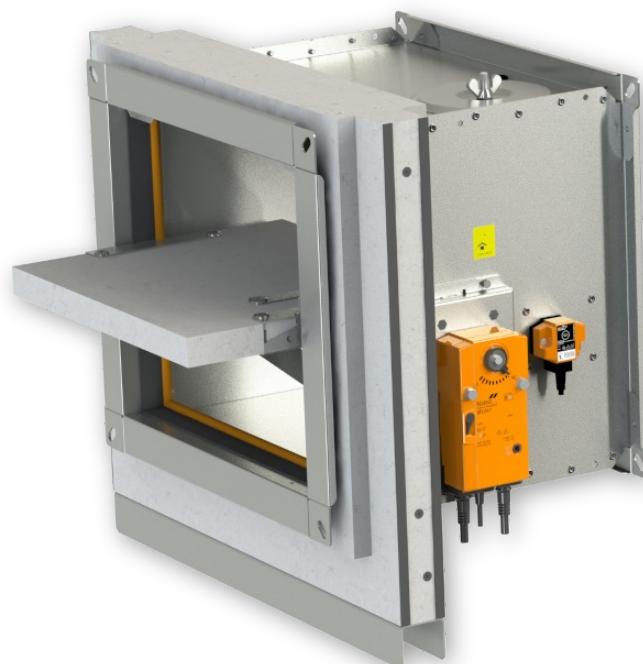
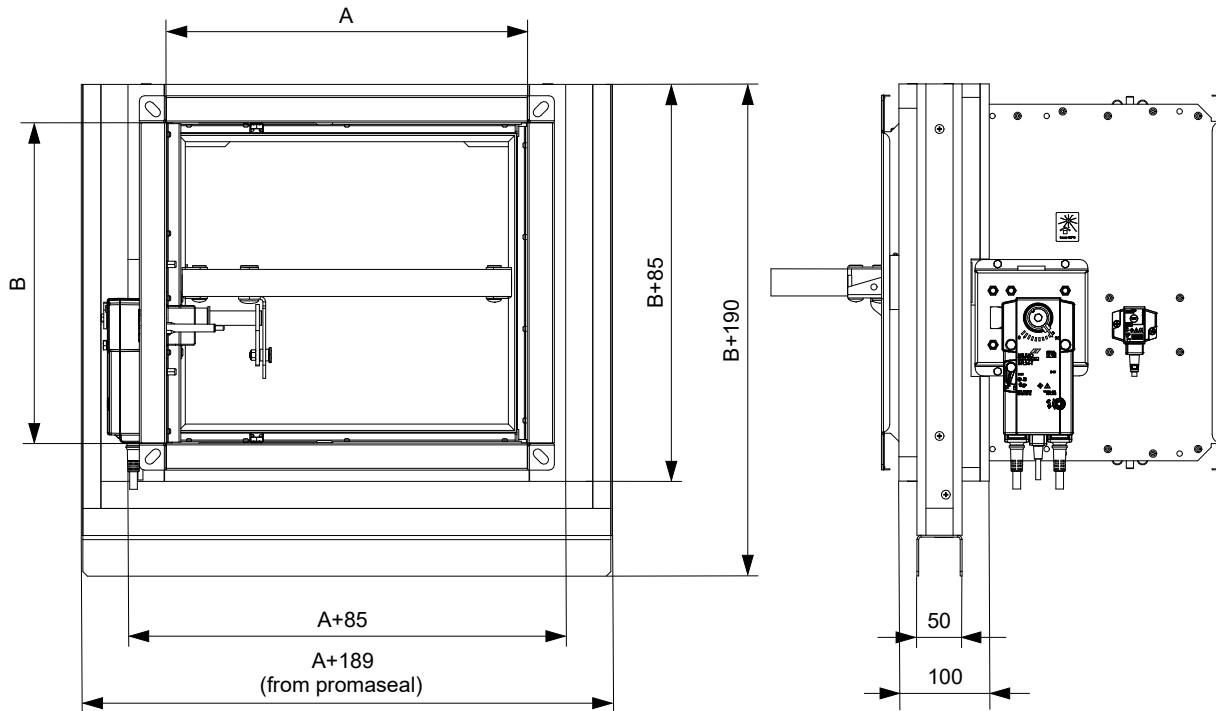

## II. INSTALLATION

### Description

- Installation frame E5 is designed for installation without additional sealing of the penetration for:
  - Installation in gypsum walls under flexible ceilings with a maximum movement of 40 mm
  - Wall thicknesses of 100 or  $\geq 115$  mm
- Position of the damper can be directly on the ceiling or at a distance of max. 80 mm from the ceiling
- E5 installation frame is designed with "sliding rails" on the sides of the frame that move in the lightweight wall so that the damper, which is attached to the ceiling, can move a maximum of 40 mm
- On the sides of the frame is Promaseal-LX SK, which fills the gap between the frame and the construction in the event of a fire

### Wall preparation

#### Installation directly on the ceiling

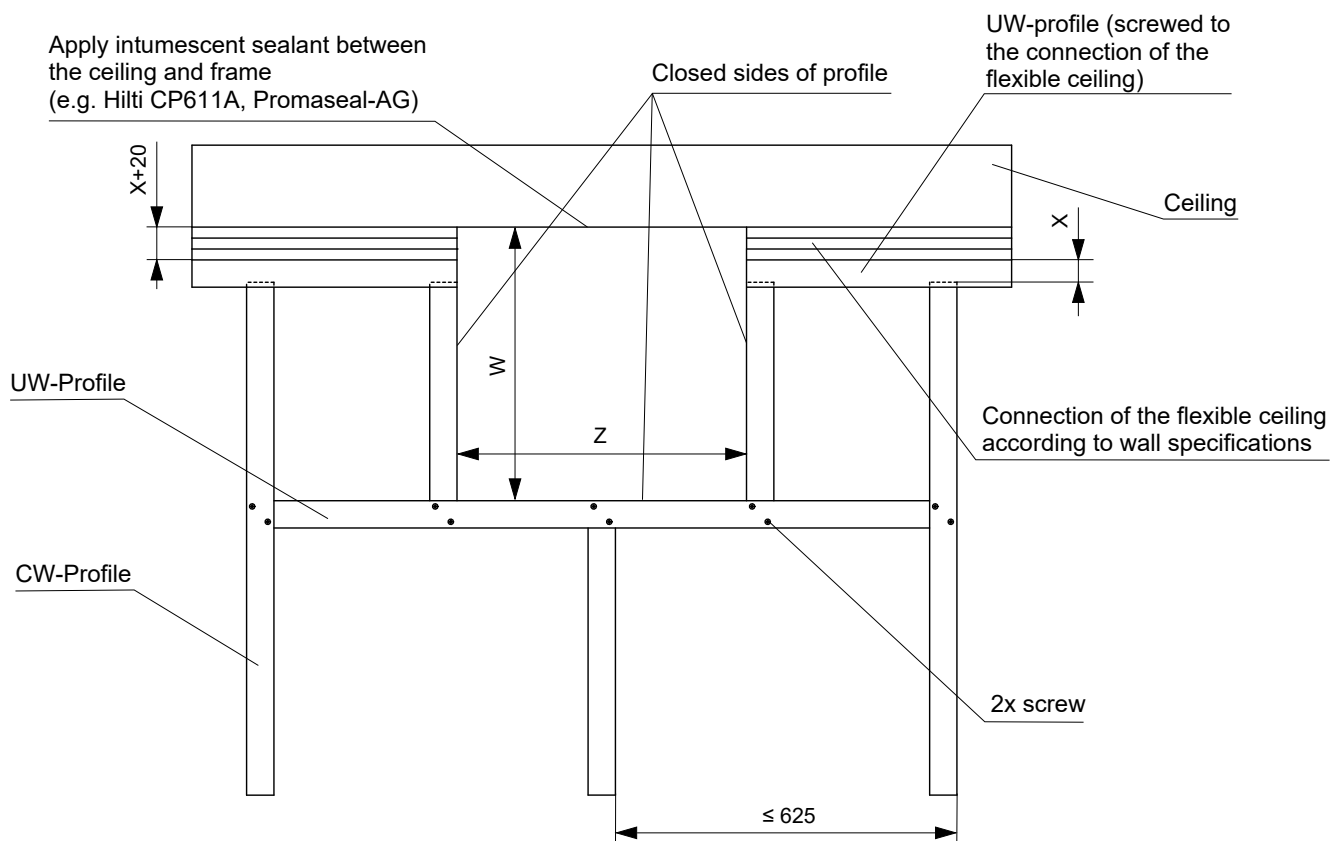

- $X$  = ceiling movement  $\leq 40$  mm
- $F$  = gap between frame (promaseal) and profile = 2 to 5 mm

$W$ [mm]	$Z$ [mm]
$B + 190 + X$	$A + 189 + (2 \times F)$

- Gypsum construction must be made in accordance with the specifications of the wall system manufacturer
- There is no need for a side profile to always be fixed in the ground and to always run in one piece to the ceiling. Multiple profiles can be used with the necessary screw connection

## Installation at a maximum distance of 80 mm from the ceiling

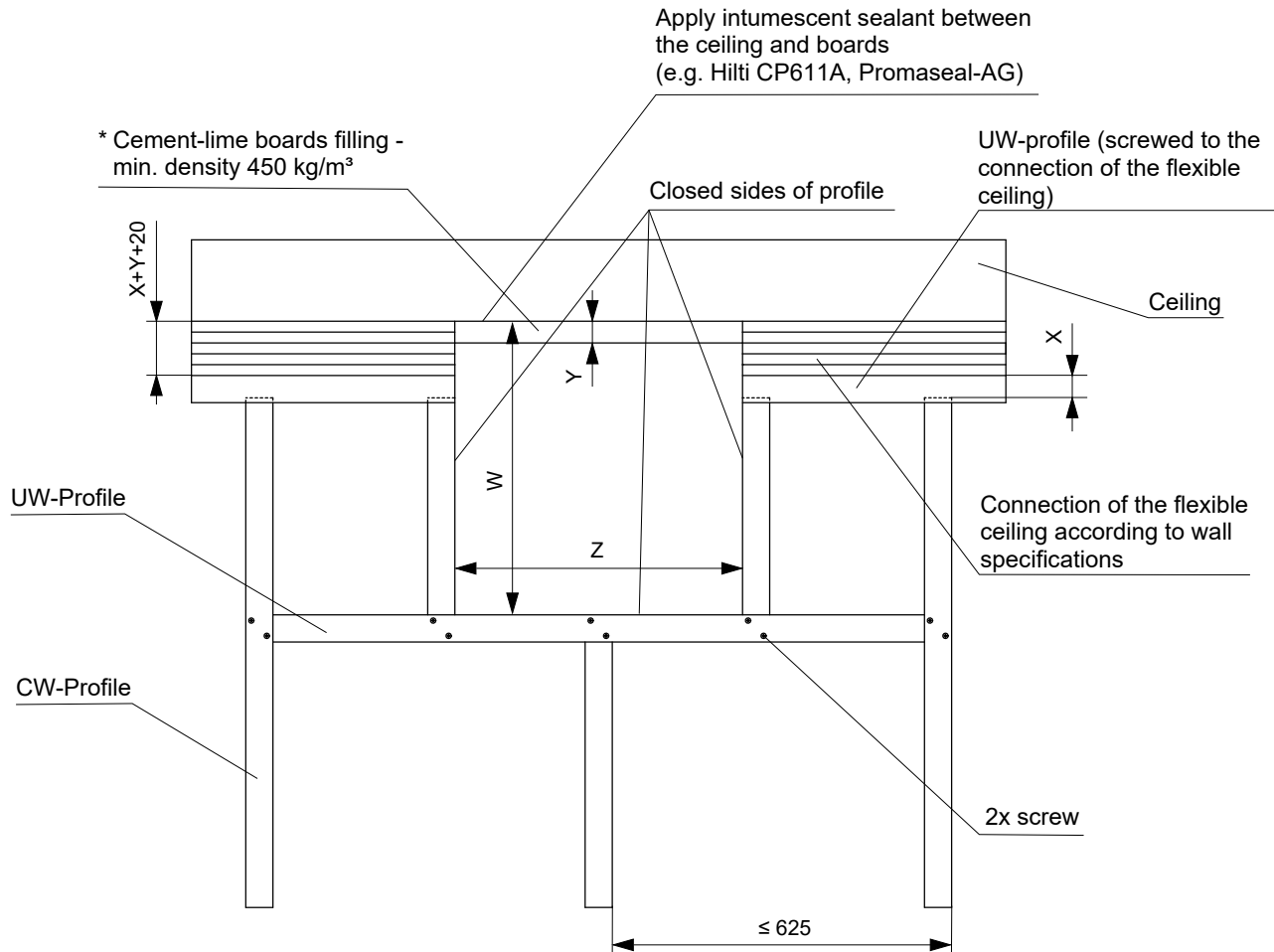

\* Width of the boards = 100 mm

- X = ceiling movement ≤ 40 mm
- Y = distance of frame from ceiling max. 80 mm
- F = gap between frame (promaseal) and profile = 2 to 5 mm

W [mm]	Z [mm]
$B + 190 + X + Y$	$A + 189 + (2 \times F)$

- Gypsum construction must be made in accordance with the specifications of the wall system manufacturer
- There is no need for a side profile to always be fixed in the ground and to always run in one piece to the ceiling. Multiple profiles can be used with the necessary screw connection

## Finishing the walls

- Fill the wall with insulation according to the type of gypsum construction
- Finally, cover the wall with gypsum boards. A larger opening must be cut in the gypsum boards than the installation frame so that the frame can move without damaging the wall
- In case of wall thickness ≥ 115 mm, cladding of the frame is necessary → see page 7 and 8

Installation frame E5 - wall thickness 100 mm

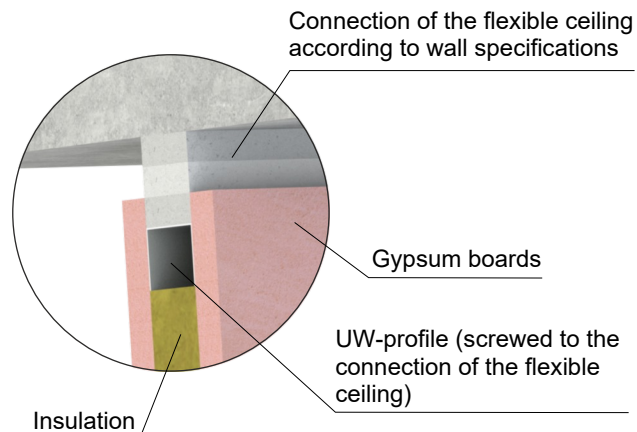
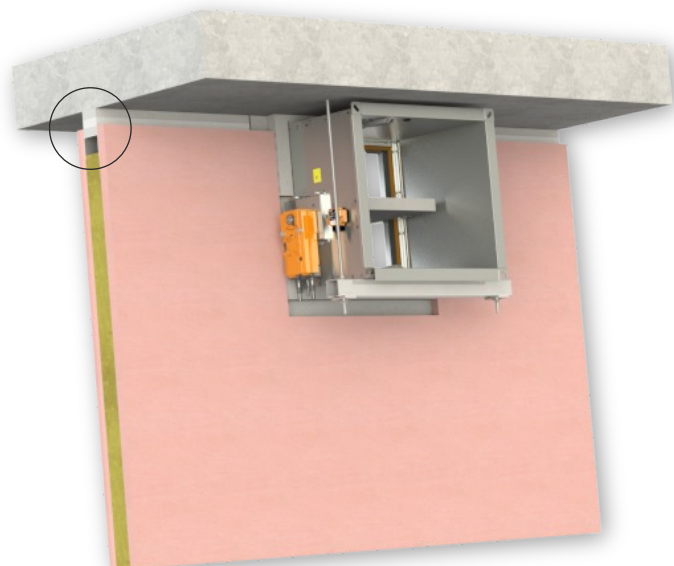

Slide into the UW-profile to allow movement

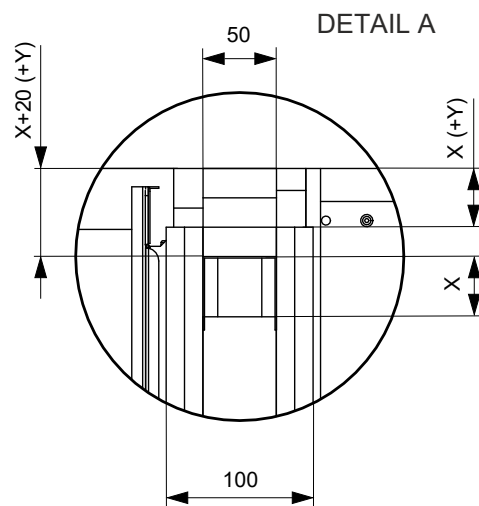
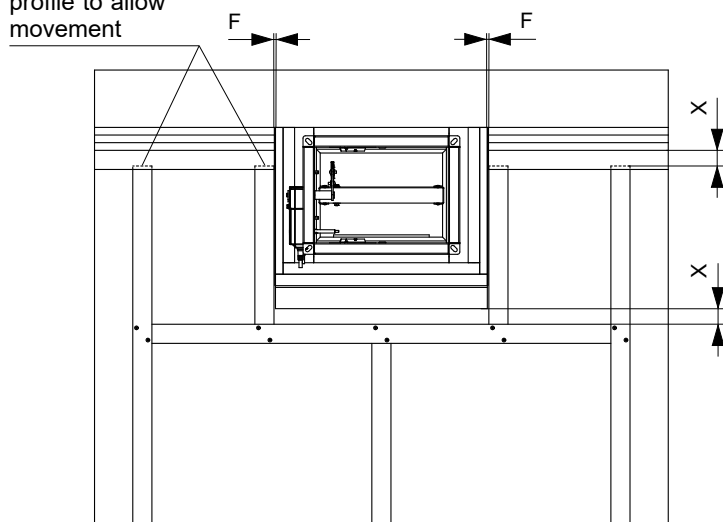

Finishing with gypsum boards - front and back side

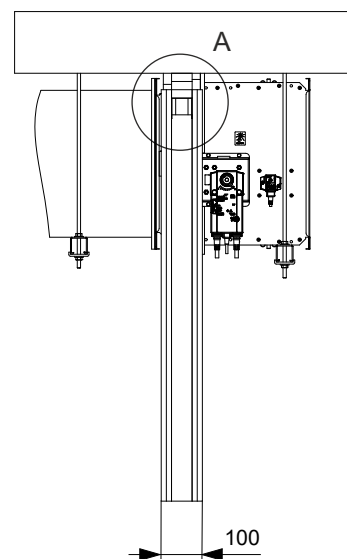
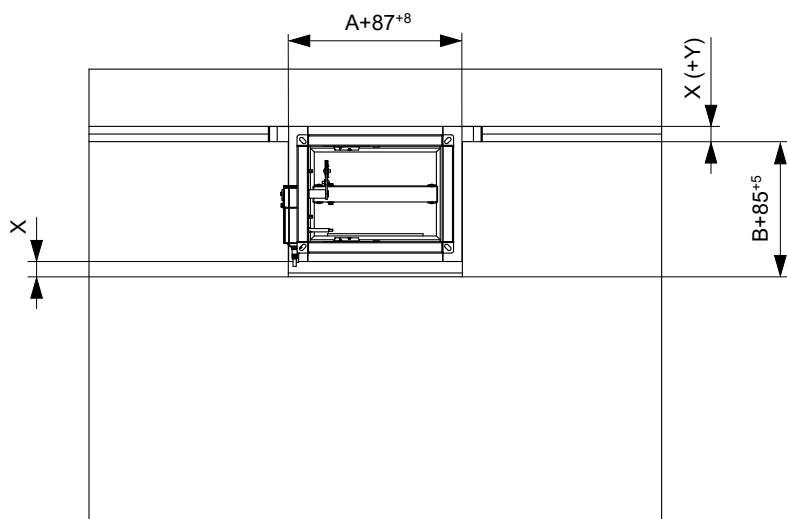

- X = ceiling movement ≤ 40 mm
- F = gap between frame (promaseal) and profile = 2 to 5 mm
- Y = only when the frame is at a distance from the ceiling (max. 80 mm) → see page 5
- For rules of finishing the walls → see page 9

Installation frame E5 - wall thickness  $\geq 115$  mm

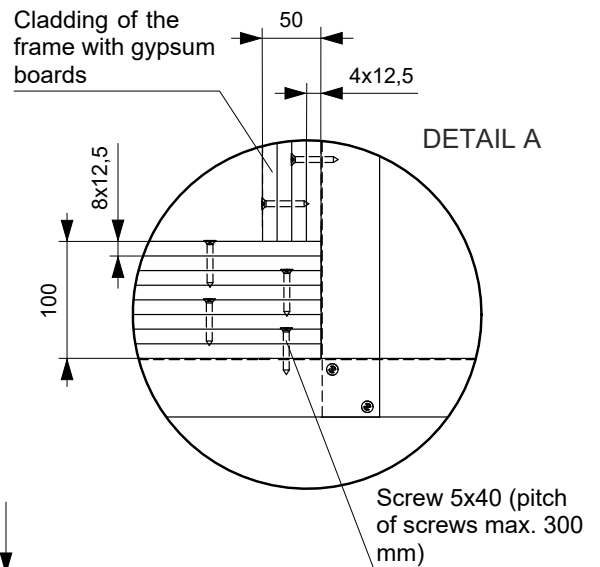
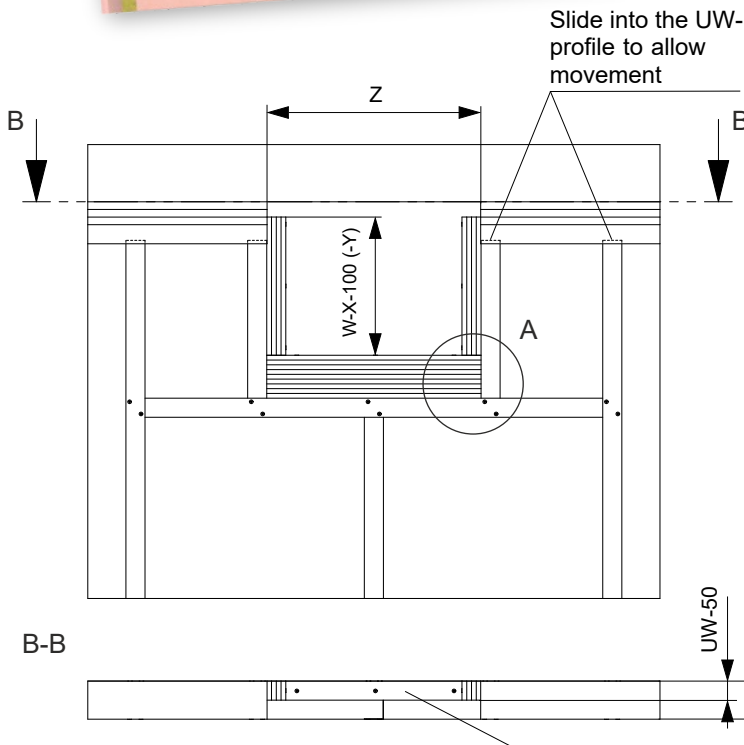
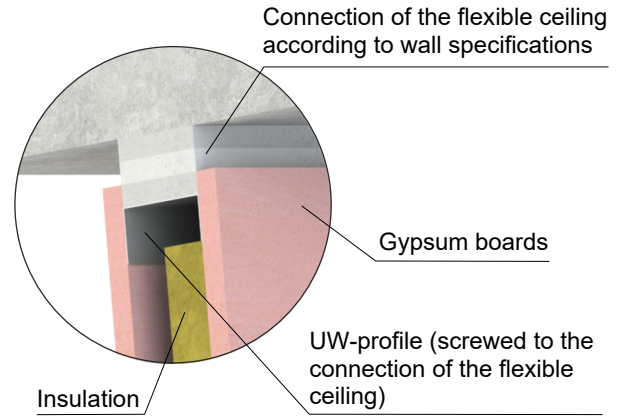
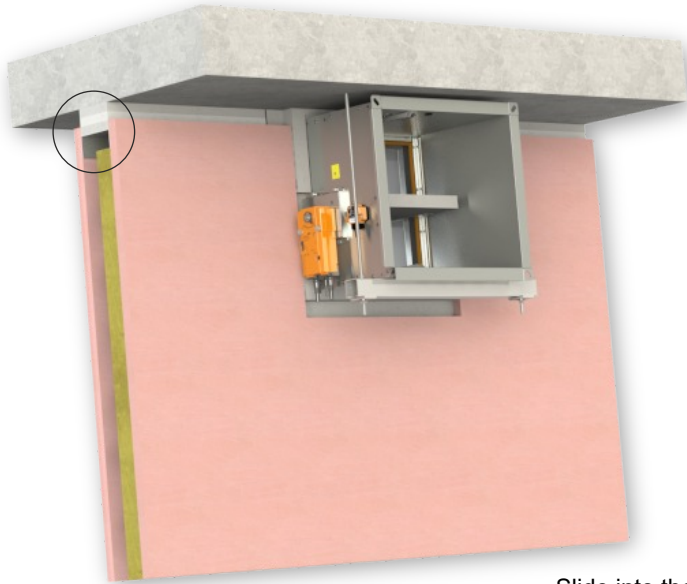

Cladding of the frame with gypsum boards

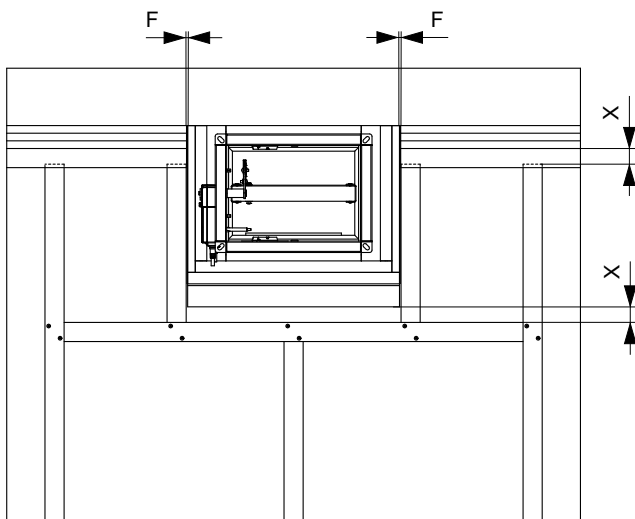

- X = ceiling movement  $\leq 40$  mm
- F = gap between frame (promaseal) and profile = 2 to 5 mm
- Y = only when the frame is at a distance from the ceiling (max. 80 mm) → see page 5
- W = → see page 4-5
- Z = → see page 4-5
- UW = UW-profile width  $\geq 65$  mm

Finishing with gypsum boards - front side

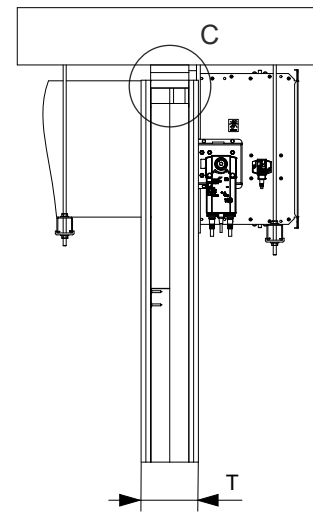
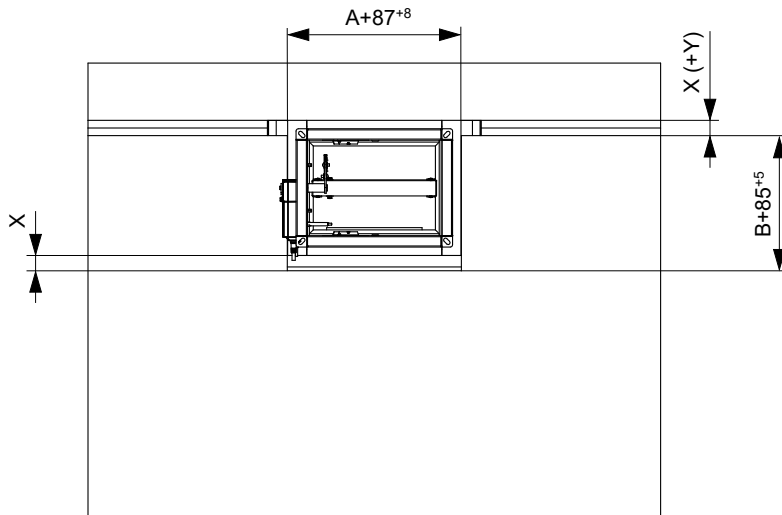

Finishing with gypsum boards - back side

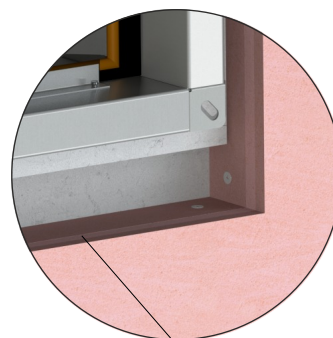
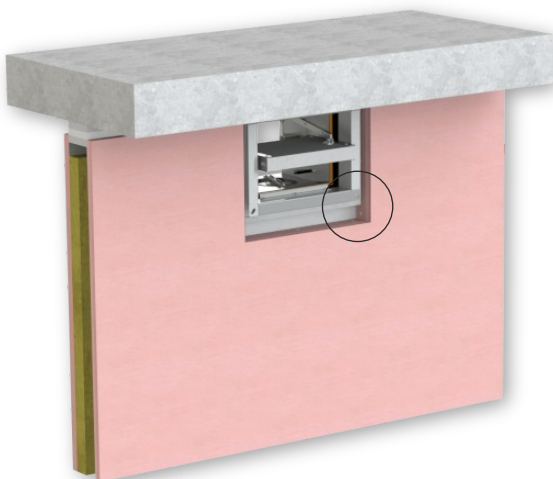
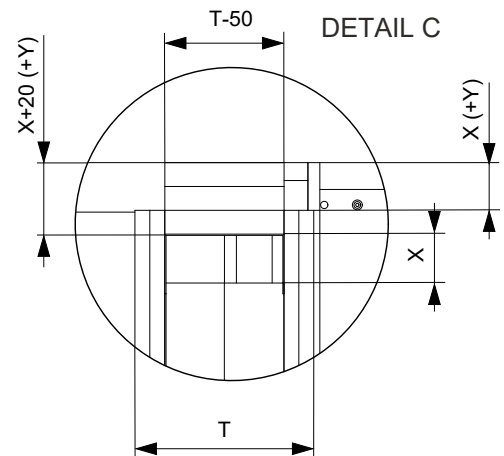
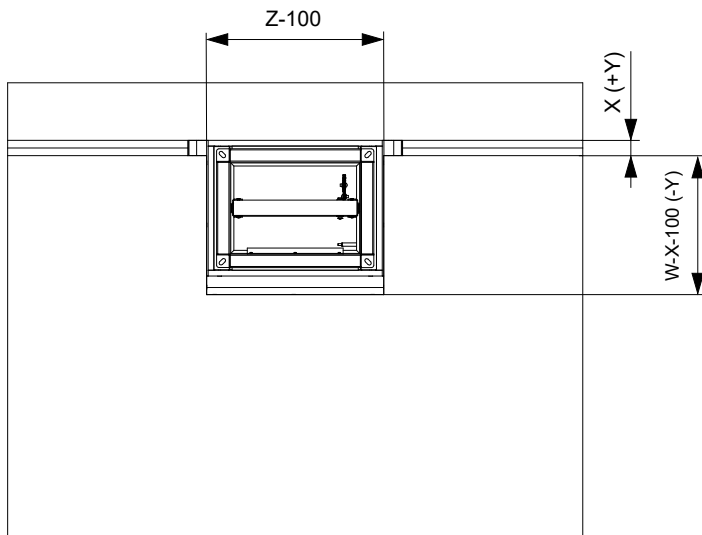

Opening in the gypsum boards at the back side ends with the cladding of the frame

- $X$  = ceiling movement  $\leq 40$  mm
- $W$  = → see page 4-5
- $Z$  = → see page 4-5
- $Y$  = only when the frame is at a distance from the ceiling (max. 80 mm) → see page 5
- $T$  = wall thickness  $\geq 115$  mm
- For rules of finishing the walls → see page 9



## Rules of finishing the walls

- Red marked area where there must be no screw connections to ensure free movement of the ceiling with the frame and avoid damage - **(front and back side of the wall!)**
- X = ceiling movement  $\leq 40$  mm
- U = UW-profile height

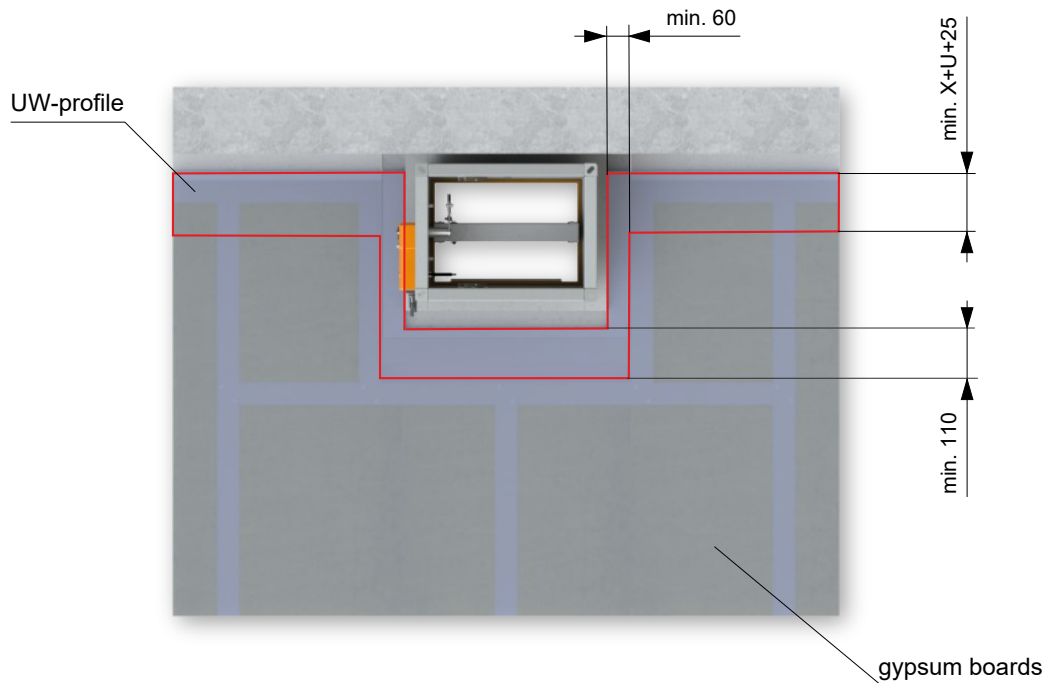

## Fixing the installation frame to the ceiling

- E5 installation frame is fixed to the ceiling with threaded rods and supports (fixing material is not delivered with the frame)

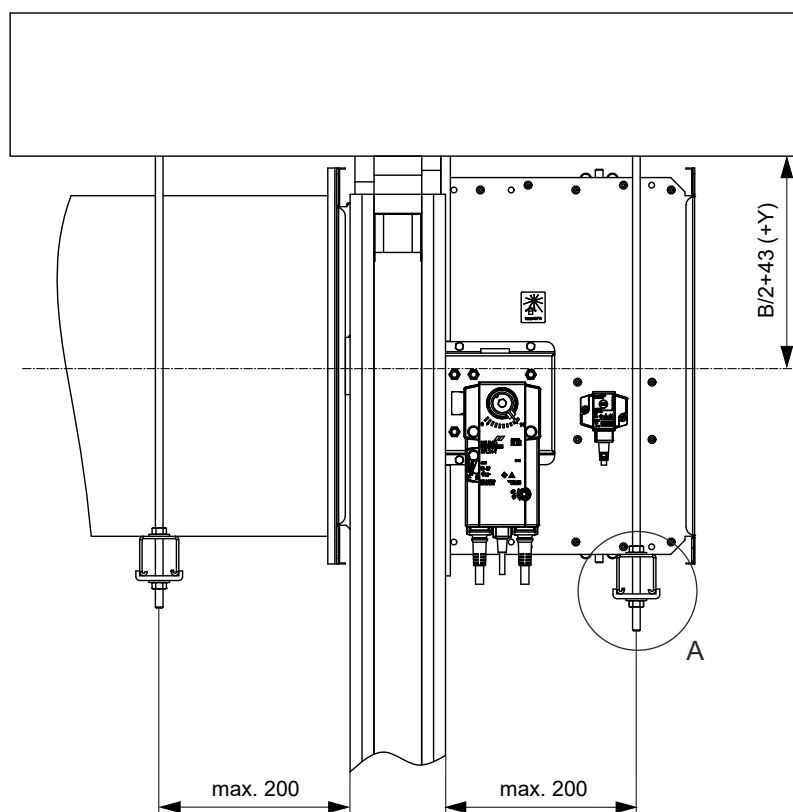
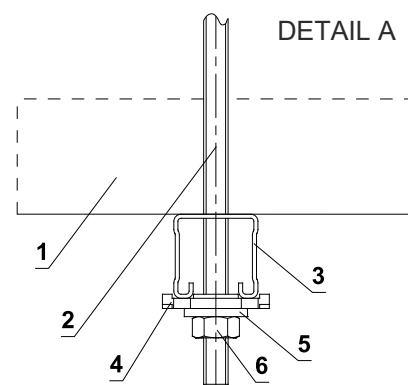
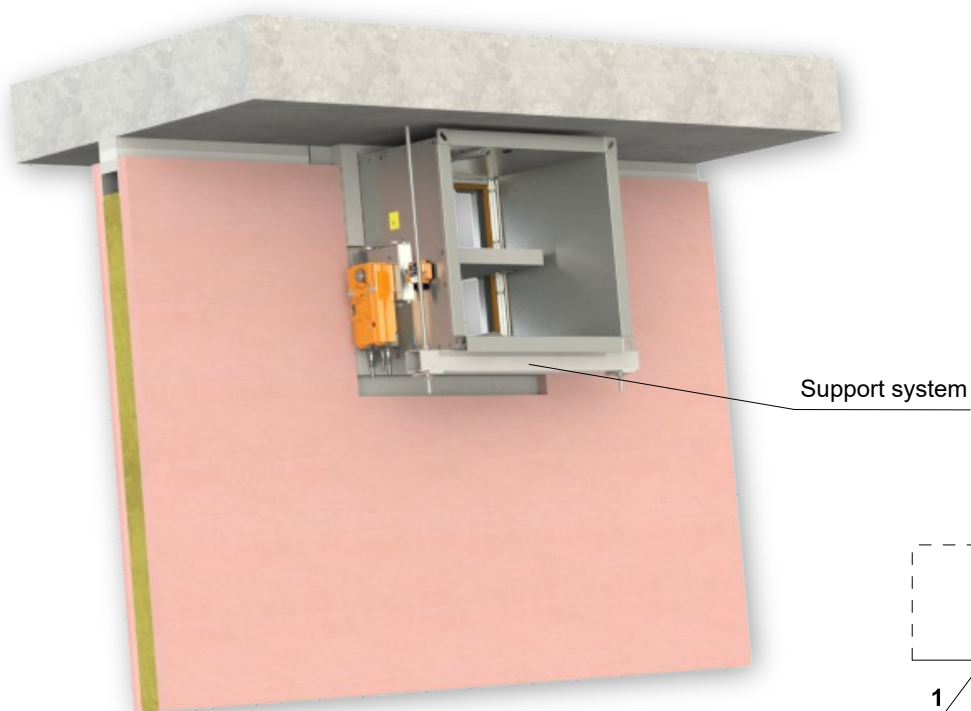

DETAIL A - side view

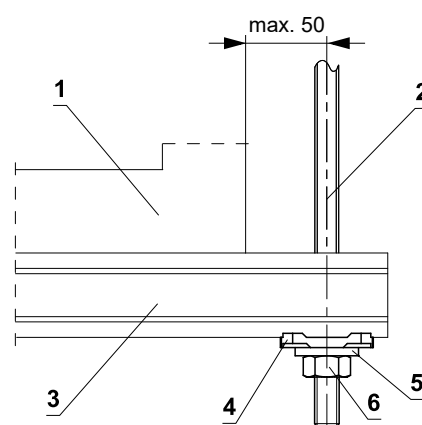

- Y = only when the frame is at a distance from the ceiling (max. 80 mm) → see page 5

- 1 Fire damper
- 2 Threaded rod M8 - M12
- 3 Support HILTI MQ-41 or MQ-41/3
- 4 Bored plate HILTI MQZ-L
- 5 Washer for M8 - M12
- 6 Nut M8 - M12

The producer reserves the right for innovations of the product.  
For actual product information see [www.mandik.com](http://www.mandik.com)

**MANDÍK**<sup>®</sup>  
[www.mandik.com](http://www.mandik.com)