

FDMB

Fire damper

Technical Documentation

Installation, Commissioning, Operation, Maintenance and Service Manual

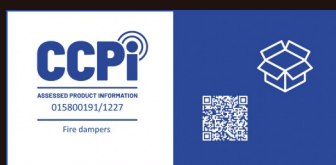
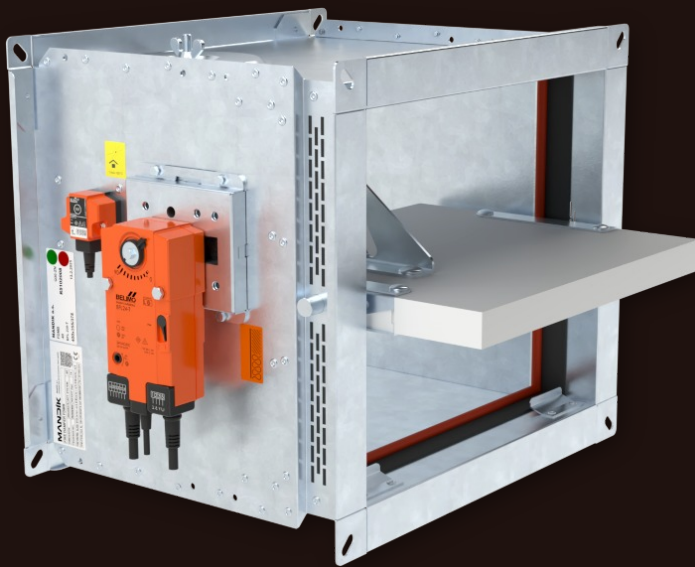

These technical specifications state a row of manufactured sizes and models of fire dampers FDMB.
It is valid for production, designing, ordering, delivery, maintenance and operation.

CONTENT

I. GENERAL.....	3	Warranty.....	82
Description.....	3	IX. ASSEMBLY, ATTENDANCE AND MAINTENANCE.....	83
II. DESIGN.....	4	Commissioning and revisions.....	88
Design with manual control.....	4	X. ORDERING INFORMATIONS.....	90
Design with spring return actuator.....	6	Ordering key.....	90
Design with the communication and supply device	12	Accessories.....	91
III. DIMENSIONS.....	14	Data label.....	92
Technical parameters.....	16		
IV. INSTALLATION.....	22		
Placement and installation.....	22		
Statement of installations.....	24		
In solid wall construction.....	25		
Installation outside solid wall construction.....	29		
In gypsum wall construction.....	32		
Installation outside gypsum wall construction.....	40		
In CLT wall construction.....	43		
In the fire barrier ROCKWOOL Fire Cavity Barrier EN	45		
.....	45		
In shaft wall construction.....	46		
In solid ceiling construction.....	48		
Outside solid ceiling construction.....	50		
In CLT ceiling construction.....	52		
Installation frames.....	54		
Installation frame E1.....	55		
Installation frame E2.....	59		
Installation frame E3.....	62		
Installation frame E4.....	64		
Installation frame E5.....	67		
Installation frame E6.....	70		
V. SUSPENSION SYSTEMS.....	73		
Example of duct connection.....	77		
VI. TECHNICAL DATA.....	78		
Pressure loss.....	78		
Noise data.....	80		
VII. MATERIAL, FINISHING.....	81		
VIII. TRANSPORTATION, STORAGE AND WARRANTY.....	82		
Logistic terms.....	82		

I. GENERAL

Description

Fire dampers are shutters in ducts of air-conditioning devices that prevent the spread of fire and combustion products from one fire segment to the other one by means of closing the duct in the points of fire separating constructions.

Damper blade automatically closes air duct using a closing spring or a spring return actuator. The closing spring is actuated by pressing a button on the manual control or by melting a thermal fuse.

The return spring of the actuator is actuated when a thermoelectric activation device BAT is activated, when a test button on BAT is pressed or when power supply of the actuator is interrupted.

After closing the blade, the damper is sealed with silicon against smoke penetration. On request by customer, the damper can be supplied silicon-free. In the closed position, the damper is also sealed with material which increases its volume due to increasing temperature and air proofs the air duct.

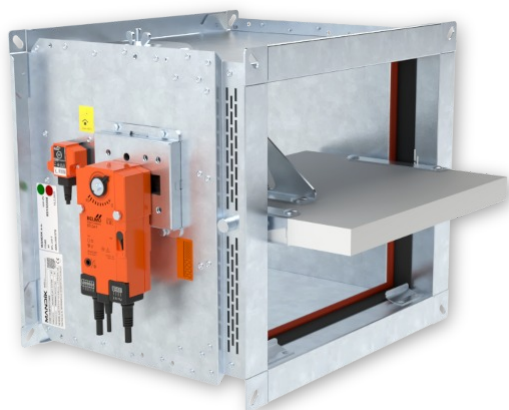

FDMB with spring return actuator

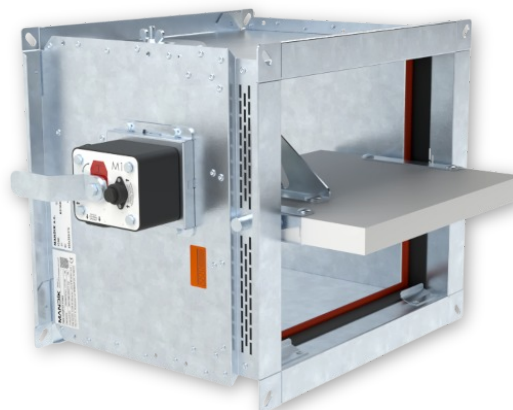

FDMB with manual control

Damper characteristics

- CE certified acc. to EN 15650
- Tested in accordance with EN 1366-2
- Classified acc. to EN 13501-3+A1
- External casing leakage for size: A<160 or B<160 class ATC 4 (old marking "B"), A≥160 a B≥160 class ATC 3 (old marking "C"), Internal leakage class 2 acc. to EN 1751
- Cycling test in class C₁₀₀₀₀ acc. to EN 15650
- Corrosion resistant acc. to EN 15650
- Certificate of constancy of performance No. 1391-CPR-XXXX/XXXX
- Declaration of Performance No. PM/FDMB/01/XX/X
- Hygienic assessment of fire dampers - Report No. 1.6/pos/19/19b

Working conditions

- Exact damper function is provided under the following conditions:
 - maximum air velocity 12 m/s
 - maximum pressure difference 1200 Pa
 - the air circulation in the whole damper section must be secured steady over the entire surface.
- Dampers are suitable for systems without abrasive, chemical and adhesive particles.
- Dampers are designed for macroclimatic areas with mild climate according to EN IEC 60 721-3-3 ed.2., class 3K22. (Environment 3K22 is typically protected place with regulated temperature)
- Temperature in the place of installation is permitted to range from -30°C to +50°C.

II. DESIGN

Design with manual control

Design .01

- Design with manual control with a thermal fuse which actuates the shutting device, after the nominal activation temperature 72°C has been reached.
- Automatic initiation of the manual control is not activated if the temperature does not exceed 70°C.
- In case that other activation temperatures are required, thermal fuses with nominal activation temperature +104°C or +147°C can be supplied (this requirement must be specified in the order).

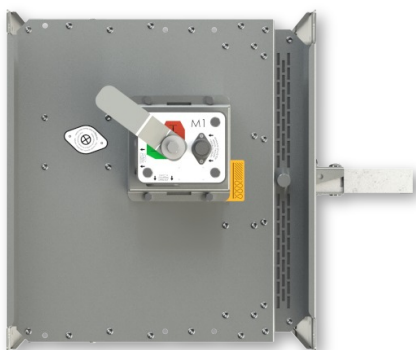

Design .01

ATTENTION:

- Manual controls are produced in three sizes M1 to M3, difference is only in size of a closing spring, which closes the fire damper.
- For the size of fire dampers is always assigned the size of the manual control → see pages 16 to 21
- It is not recommended to use different size of the manual control than given by the manufacturer, otherwise there is a risk of damaging the fire damper.

Design .11

- Design .01 with manual control can be complemented with a limit switch signaling of the damper blade position "CLOSED".
- Cable is connected directly to limit switch.
- Limit switch detail → see page 5

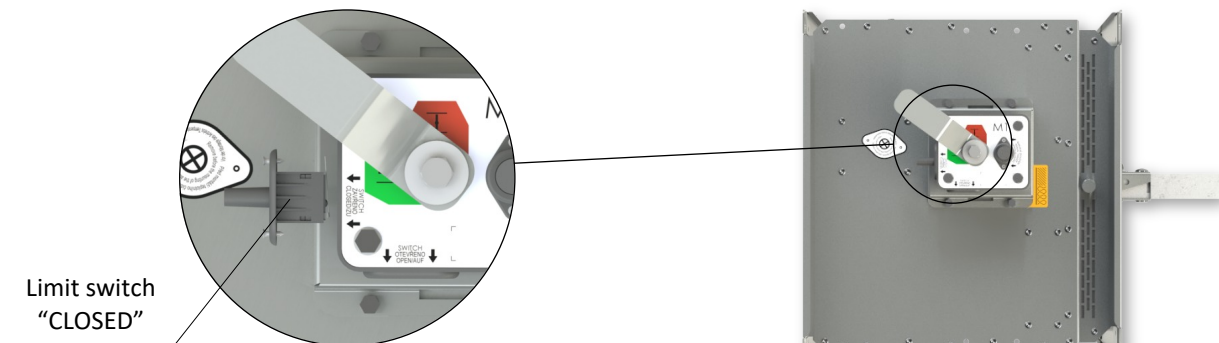

Design .11

Design .80

- Design .01 with manual control can be complemented with two limit switches signaling of the damper blade position "CLOSED" and "OPEN".
- Cables are connected directly to limit switches.
- Limit switch detail → see page 5

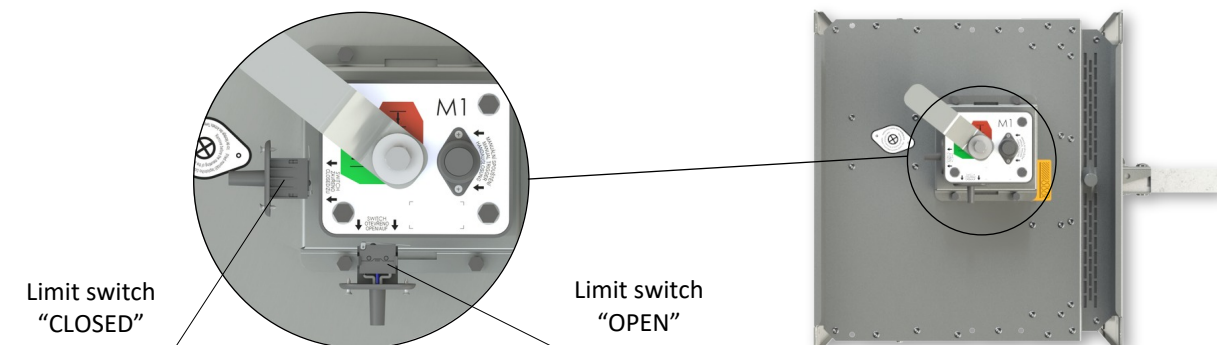

Design .80

Manual control

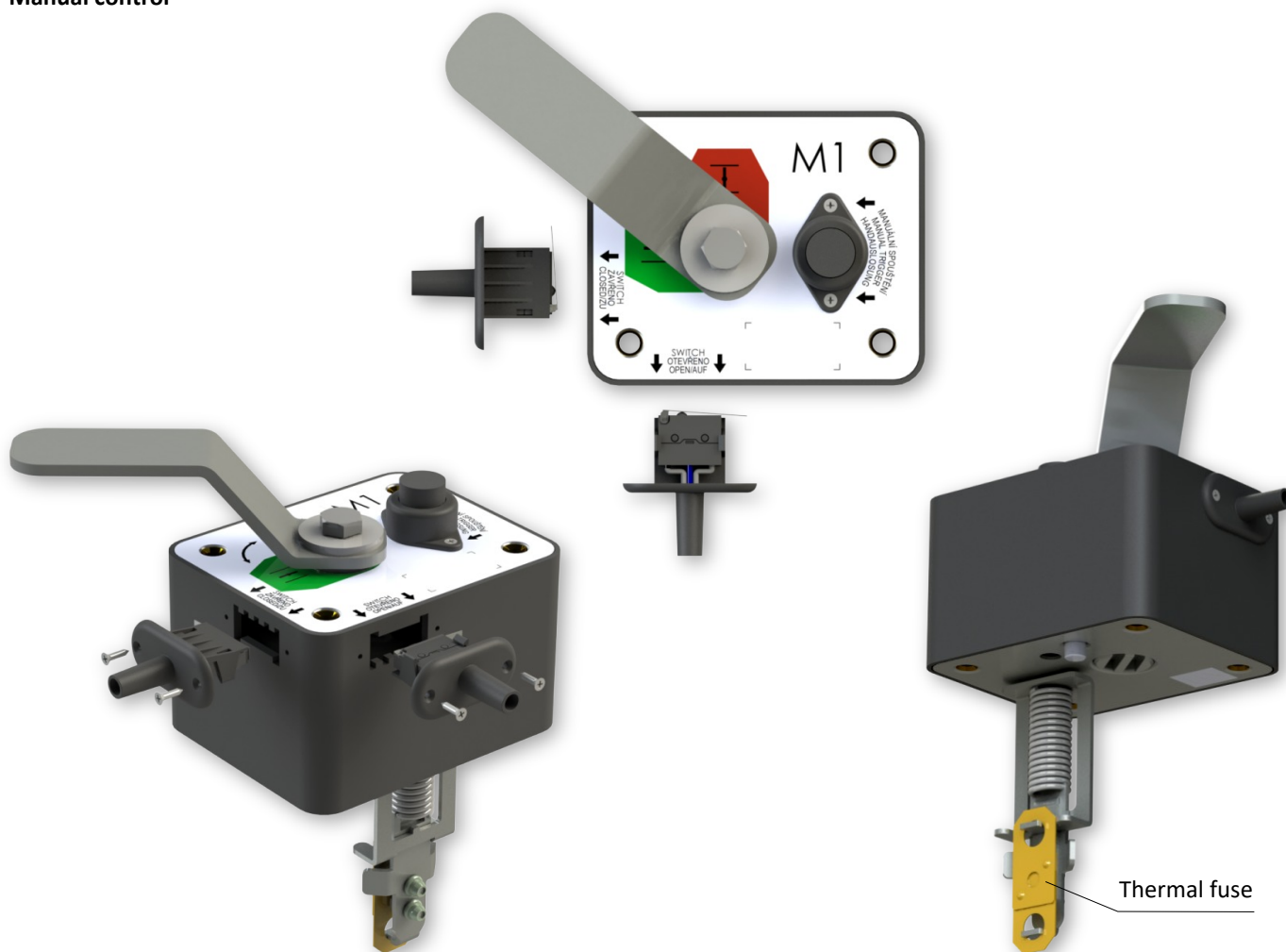

Limit switch G905-300E03W1

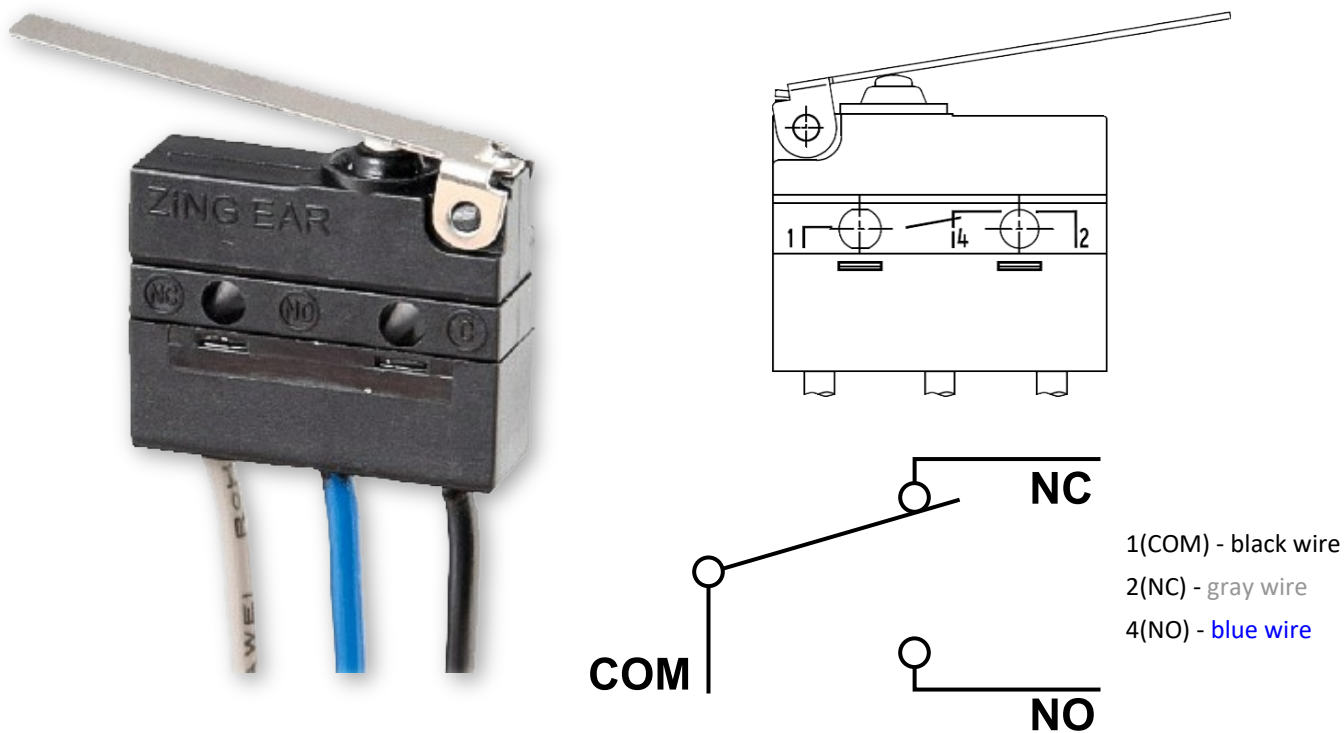

Nominal voltage and maximal current	AC 230V / 5A
Class of protection	IP 67
Working temperature	-25°C ... +120°C

This limit switch is possible to connect in two following ways

- CUT-OFF if the arm is moving ... connect wire 1+2
- SWITCH-ON if the arm is moving ... connect wire 1+4

Design with spring return actuator

Design .40 and .50

- The fire dampers are equipped with Belimo spring return actuators with thermoelectric activation device BAT. The spring return actuator types are BFL, BFN or BF depending on the damper size. (Further mentioned as „actuator“).
- After being connected to power supply 230V or AC/DC 24V, the actuator rotates the damper blade to the operating position "OPEN" and at the same time pre-stretches its return spring.
- When the actuator is power supplied, the damper blade is in the position "OPEN" and the return spring is pre-stretched.
- Time needed for full opening of the damper blade from the position "CLOSED" to the position "OPEN" is maximum 120 sec. If the actuator power supply is interrupted (due to loss of supply voltage, or pressing a test button on the thermoelectric activation device BAT), the actuator rotates the damper blade to the breakdown position "CLOSED".
- The time of closing the damper blade from the position "OPEN" to the position "CLOSED" takes maximum 20 sec.
- In case that the power supply is restored again (the blade can be in any position), the actuator starts to rotate the damper blade back to the position "OPEN".
- A thermoelectric activation device BAT, which contains two thermal fuses Tf1 and Tf2, is an integral part of the actuator.
- These fuses are activated when temperature +72°C has been reached (the fuse Tf1 due to temperature outside the duct and the fuse Tf2 due to temperature inside the duct). The thermoelectric activation device can also be equipped with a Tf2 thermal fuse type ZBAT 95/120/140 (must be specified in the order). In this case, the activation temperature inside the duct is +95°C, +120°C or +140°C (depending on the type).
- After the thermal fuse Tf1 or Tf2 has been activated, the power supply is permanently and irreversibly interrupted and the actuator, by means of the pre-stretched spring, rotates the damper blade into the breakdown position "CLOSED".
- Signalisation of damper blade position "OPEN" and "CLOSE" is provided by two microswitches.

Thermoelectric activation device BAT

Spring return actuator

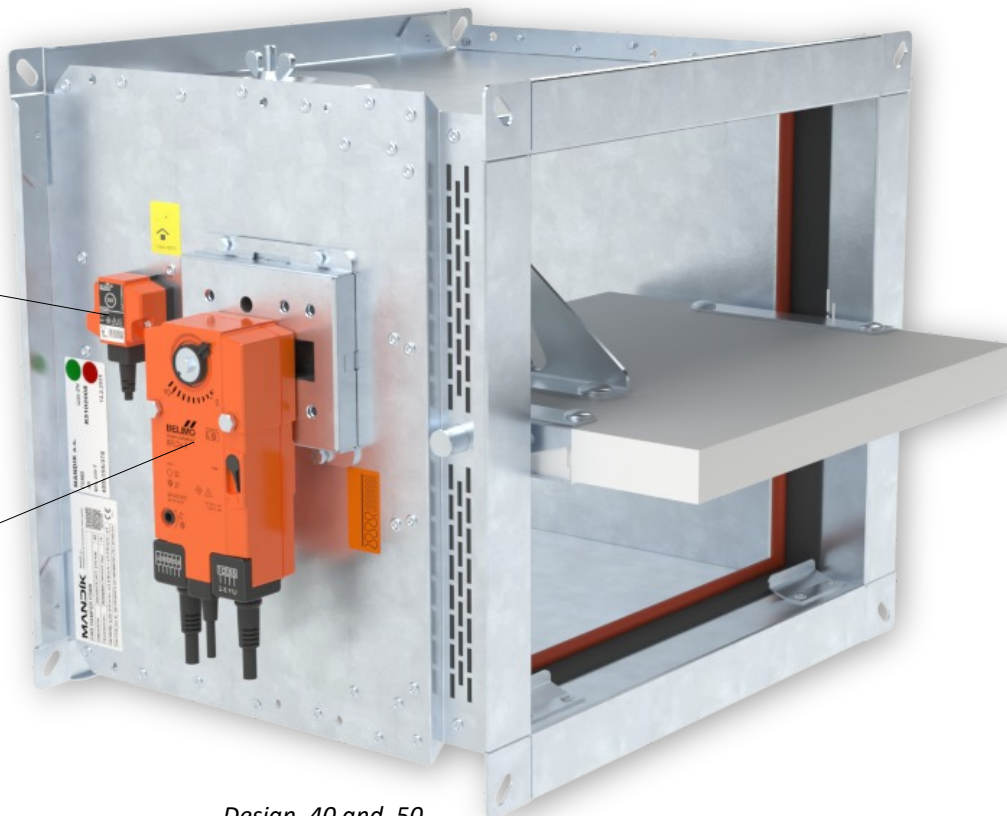

Design .40 and .50

Actuator BELIMO BFL 230-T

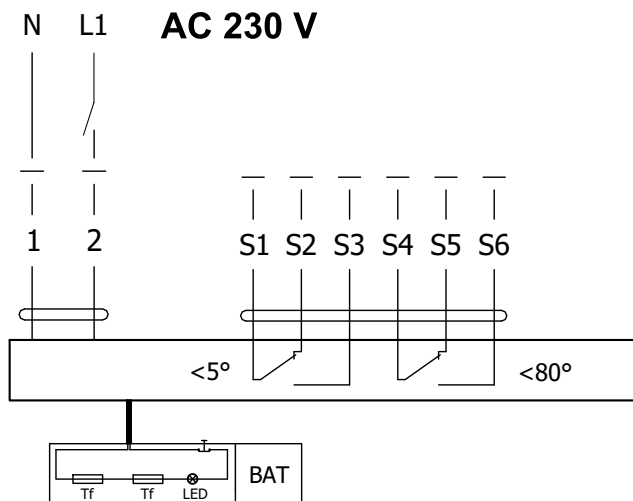

Actuator BELIMO BFL 24-T(-ST)

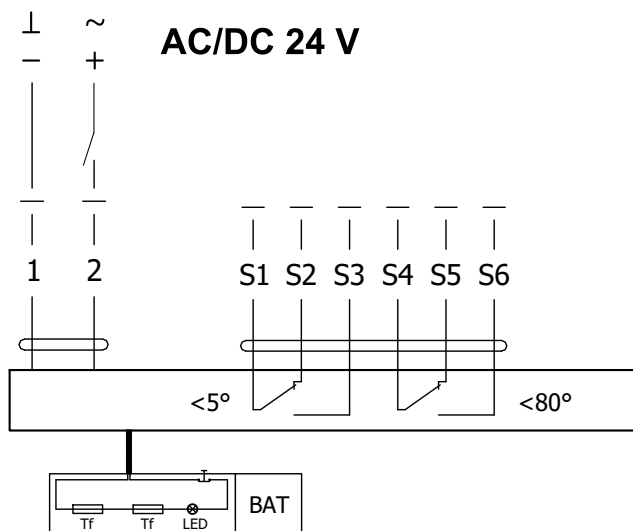

Actuator BELIMO BFL 230-T(-ST), BFL 24-T(-ST)

Actuator BELIMO - 4 Nm/ 3 Nm Spring	BFL 230-T(-ST)	BFL 24-T(-ST)
Power voltage	AC 230 V 50/60Hz	AC/DC 24 V 50/60Hz
Power consumption - in operation - in rest position	2,6 W 0,7 W	2,0 W 0,7 W
Dimensioning	4 VA (I _{max} 4 A @ 5 ms)	2,8 VA (I _{max} 2,9 A @ 5 ms)
Protection class	II	III
Degree of protection	IP 54	
Running time - motor - spring return	< 60 s ~ 20 s	
Ambient temperature - normal duty - safety duty - non-operating temperature	-30°C ... +55°C The safe position will be attained up to max. +75°C -40°C ... +55°C	
Connection - supply/control - auxiliary switch	cable 1 m, 2 x 0,75 mm ² (BFL 2xx-T-ST) with 3-pin plug-in connectors cable 1 m, 6 x 0,75 mm ² (BFL 2xx-T-ST) with 6-pin plug-in connectors	
Response temperature thermal fuse	duct outside temperature +72°C duct inside temperature +72°C	

Actuator BELIMO BFN 230-T

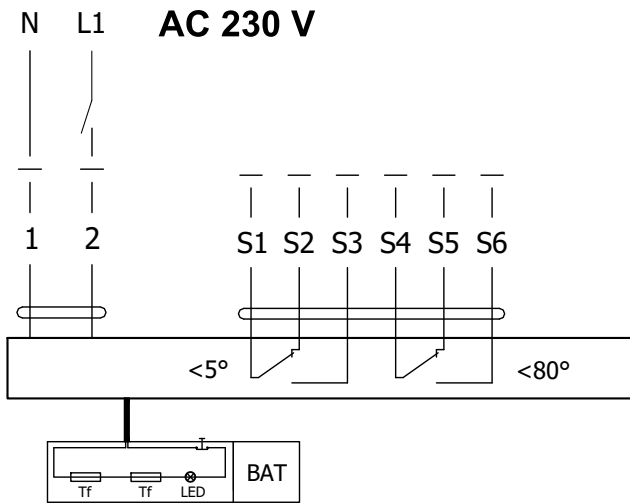

Actuator BELIMO BFN 24-T(-ST)

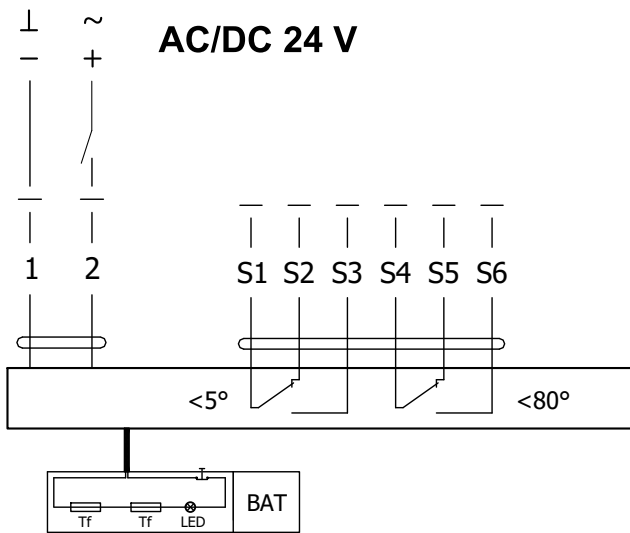

Actuator BELIMO BFN 230-T(-ST), BFN 24-T(-ST)

Actuator BELIMO - 9 Nm/ 7 Nm Spring	BFN 230-T(-ST)	BFN 24-T(-ST)
Power voltage	AC 230 V 50/60Hz	AC/DC 24 V 50/60Hz
Power consumption - in operation - in rest position	3,5 W 1,3 W	3,2 W 1,2 W
Dimensioning	6,5 VA (Imax 4 A @ 5 ms)	4,3 VA (Imax 2,9 A @ 5 ms)
Protection class	II	III
Degree of protection	IP 54	
Running time - motor - spring return	< 60 s ~ 20 s	
Ambient temperature - normal duty - safety duty - non-operating temperature	-30°C ... +55°C The safe position will be attained up to max. +75°C -40°C ... +55°C	
Connection - supply/control - auxiliary switch	cable 1 m, 2 x 0,75 mm ² (BFN 2xx-T-ST) with 3-pin plug-in connectors cable 1 m, 6 x 0,75 mm ² (BFN 2xx-T-ST) with 6-pin plug-in connectors	
Response temperature thermal fuse	duct outside temperature +72°C duct inside temperature +72°C	

Actuator BELIMO BF 230-TN

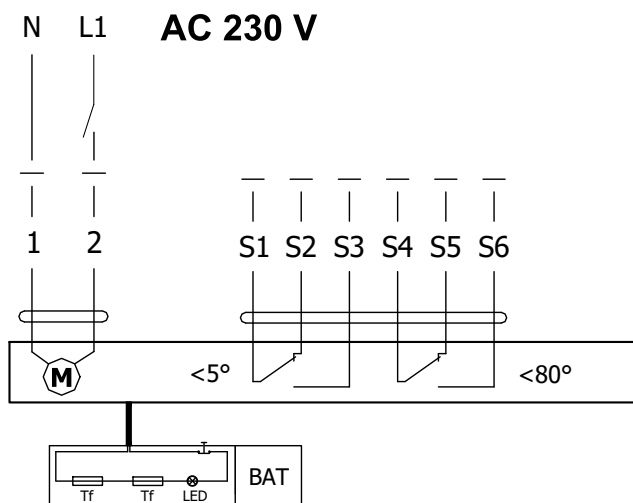

Actuator BELIMO BF 24-TN (-ST)

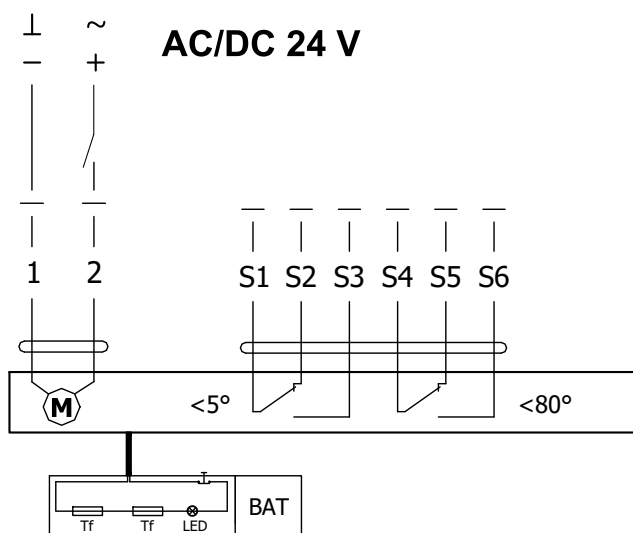

Actuator BELIMO BF 230-TN(-ST), BF 24-TN(-ST)

Actuator BELIMO - 18 Nm/ 12 Nm Spring	BF 230-TN(-ST)	BF 24-TN(-ST)
Power voltage	AC 230 V 50/60Hz	AC/DC 24 V 50/60Hz
Power consumption - in operation - in rest position	8,5 W 3 W	7 W 2 W
Dimensioning	11 VA (I _{max} 8,3 A @ 5 ms)	10 VA (I _{max} 8,3 A @ 5 ms)
Protection class	II	III
Degree of protection	IP 54	
Running time - motor - spring return	120 s ~ 16 s	
Ambient temperature - normal duty - safety duty - non-operating temperature	-30°C ... +50°C The safe position will be attained up to max. +75°C -40°C ... +50°C	
Connection - supply/control - auxiliary switch	cable 1 m, 2 x 0,75 mm ² (BF 2xx-TN-ST) with 3-pin plug-in connectors cable 1 m, 6 x 0,75 mm ² (BF 2xx-TN-ST) with 6-pin plug-in connectors	
Response temperature thermal fuse	duct outside temperature +72°C duct inside temperature +72°C	

Thermoelectric activation device BAT

- If the thermal fuse Tf1 is interrupted (due to temperature outside the duct), it is necessary to replace the spring return actuator. Thermoelectric activation device BAT is integral part of the actuator.
- If the thermal fuse Tf2 is interrupted (due to temperature inside the duct), only the spare part ZBAT 72 (95/120/140) needs to be replaced (acc.to the activation temperature).
- When one of the thermal fuses responds, the supply voltage is interrupted permanently and irreversibly.
- The function (interruption of the supply voltage) can be checked by pressing the test button.
- Installation is carried out with the pre-assembled, self-tapping screws.



BELIMO ZBAT 72
Black (BK) = 72°C (standard)

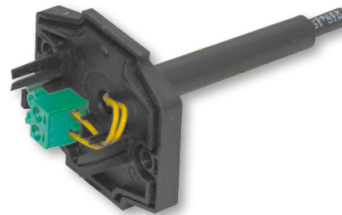

BELIMO ZBAT 95
Grey (GY) = 95°C

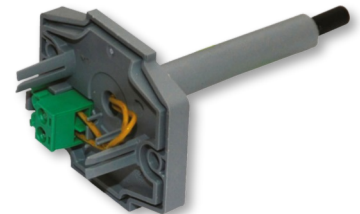

BELIMO ZBAT 120
Orange (OG) = 120°C

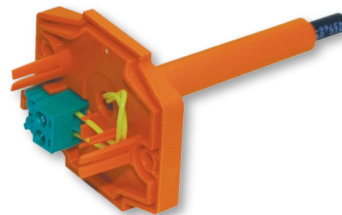

BELIMO ZBAT 140
Red (RD) = 140°C

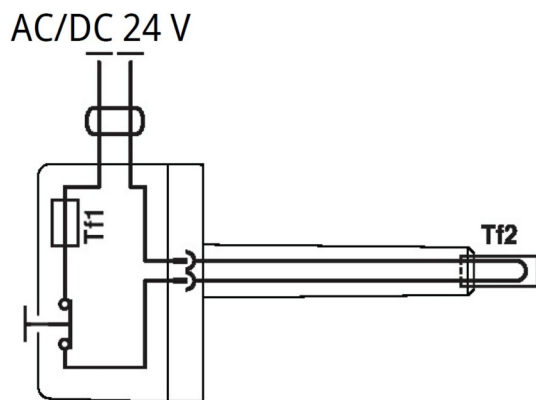
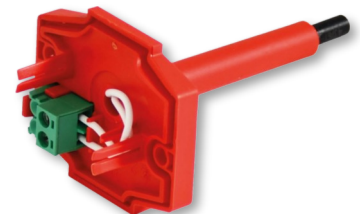

Thermoelectric activation device BAT 72 (95/120/140)

Power voltage	AC/DC 24 V 50/60Hz
Rated current	1 A
AC/DC throughput resistance	<1 Ω
Protection class	III
Degree of protection	IP 54
Probe length	65 mm
Ambient temperature	-30°C ... +50°C
Storage temperature	-40°C ... +50°C
Ambient humidity	Max. 95% RH, non-condensing
Connection supply	Cable 1 m, 2 x 0.5 mm ² , Betaflam cable heatresistant up to 145°C
Response temperature thermal fuse	Duct inside temperature +72 (95/120/140)°C Duct outside temperature +72 (95/120/140)°C

Design .41 and .51

- Design .41 or .51 with actuator and smoke detector ORS 142 K. The voltage can be AC 230 V or 24 V DC. Design .41 with voltage AC 230 V is equipped with communication and supply device BKN 230-24-MOD and with actuator BF 24-TN (BFL 24-T, BFN 24-T).
- The smoke detector is activated when smoke spreads in air duct system. Deactivation of the smoke detector alarm

status is provided by interruption of supply voltage for min. 2s.

- Signalisation of damper blade position "OPEN" and "CLOSE" is provided by two microswitches.
- For sizes A<160 mm or B<160 mm, the optical smoke detector ORS 142 K is not part of the fire damper and is supplied separately.

Design .41 with actuator BF 24-TN (BFL, BFN 24-T), with smoke detector ORS 142 K and with supply device BKN 230-24-MOD (voltage AC 230 V)

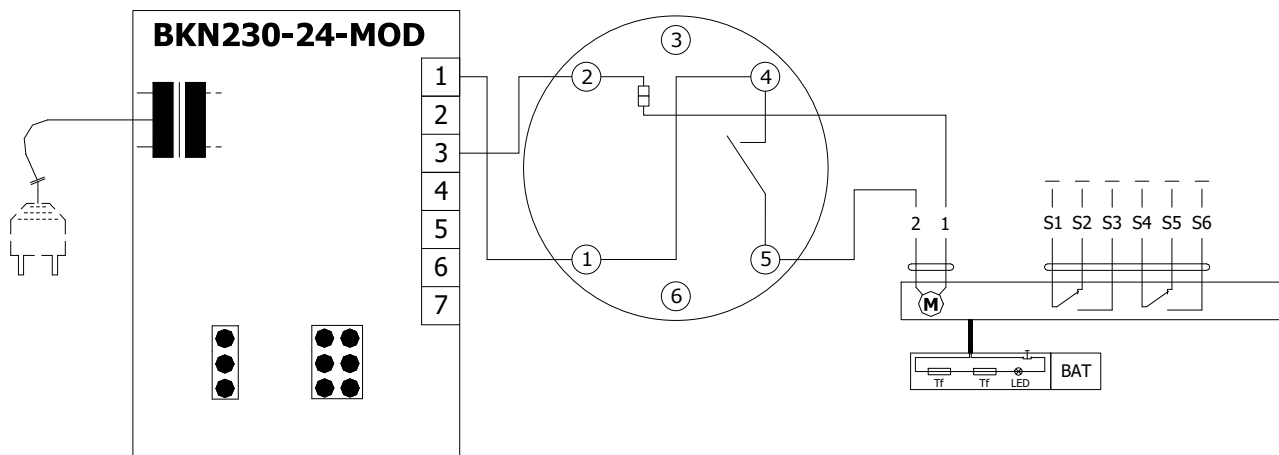

Design .51 with actuator BF 24-TN (BFL, BFN 24-T), with smoke detector ORS 142 K (voltage 24 V DC)

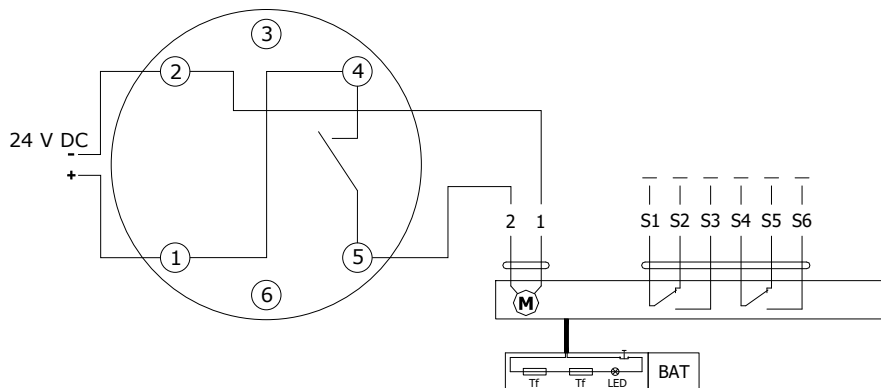

Communication and supply device BKN 230-24-MOD

Nominal voltage	AC 230 V 50/60Hz
Power consumption	3 W (operating position)
Dimensioning	14 VA (including actuator)
Protection Class	II
Degree of protection	IP 40
Ambient temperature	-20°C ... +50°C
Non-operating temperature	-40°C ... +80°C
Connection - net	cable 0,9 m with EURO plug type 26
- motor	6-pole connector, 3-pole connector
- terminal board	screw terminals for cable 2x1,5 mm ²

Design with the communication and supply device

Design .63, 63S

- Design with the communication and supply device BKN 230-24-MOD and actuator BF 24-TN-ST (BFL 24-T-ST, BFN 24-T-ST) for communication with control systems using the Modbus RTU or BACnet MS / TP. Design 63. can be extended with an optical smoke detector ORS 142 K (design .63S).
- The wiring of the line is to be carried out in accordance with applicable RS485 regulations.
- Parameterization of the communication is done using DIL switches.
- BKN 230-24-MOD can be installed separately, without a connection to a master control system, in which case the connection bridge between the terminals 1 and 4 must be installed.
- If the test button on BAT is pressed or if the power supply (e.g. by a signal from ELECTRICAL FIRE SIGNALISATION) is disconnected, the damper blade position will be "FAILURE".
- For design .63S the smoke detector is activated when smoke spreads in air duct system. Deactivation of the smoke detector alarm status is provided by interruption of supply voltage for min. 2s.
- For sizes A<160 mm or B<160 mm, the optical smoke detector ORS 142 K is not part of the fire damper and is supplied separately.

Design with communication and supply device BKN 230-24-MOD, with actuator BF 24-TN-ST (BFL 24-T-ST, BFN 24-T-ST) and smoke detector ORS 142 K

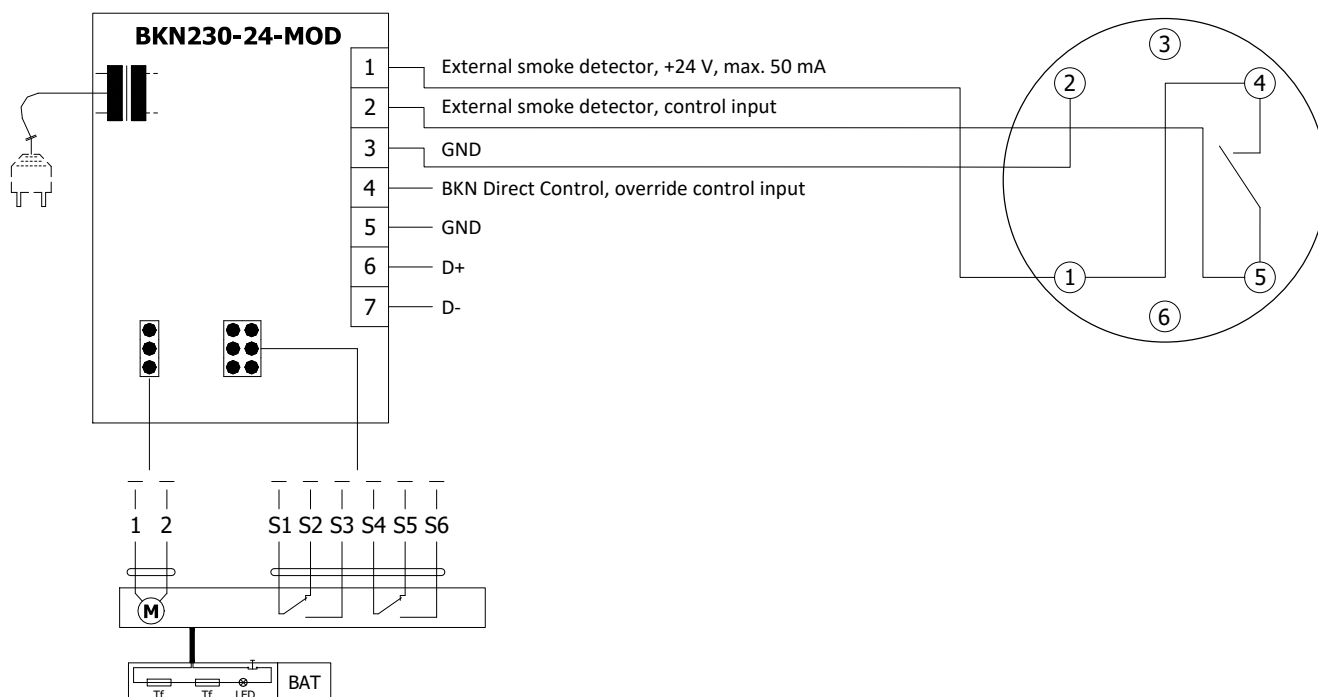

Communication and supply device BKN 230-24-MOD

Nominal voltage	AC 230 V 50/60Hz
Power consumption	3 W (operating position)
Dimensioning	14 VA (including actuator)
Protection Class	II
Degree of protection	IP 40
Ambient temperature	-20°C ... +50°C
Non-operating temperature	-40°C ... +80°C
Connection - net	cable 0,9 m with EURO plug type 26
- motor	6-pole connector, 3-pole connector
- terminal board	screw terminals for cable 2x1,5 mm ²

Optical smoke detector ORS 142 K with the socket 143A

- The smoke detector ORS 142 K is used for early smoke detection in rooms or inside the ventilation system.
- The sensor operates on the light scatter principle. Inside the scanning chamber is a light source and a light sensor, in the normal state the light from the source does not fall on the sensor. Only when smoke enters the scanning chamber the light is scattered and falls on the sensor.
- The smoke detector can be connected directly to the actuator (design .41 and .51) which, in case of smoke detection, passes to the safety position, or to the BKN communication and supply device (design .63).
- By early detection of smoke, it can be effectively prevented from spreading of smoke through the ventilation system. In addition to smoke detection, the sensor can distinguish and signal slight and heavy contamination, e.g. the presence of large amounts of dust.
- The ORS 142 K smoke detector has an alarm memory, i.e. if the alarm is triggered, the safety relay opens and stays in this state even if the smoke disappears from the scanning chamber. The sensor remains in the alarm state until the power supply is briefly reset.
- On the pin 3, an external device can be connected via RS-Bus communication to report the status of the sensor.
- Pin 6 has no connection to the detector and is designed as a load-bearing structure in the base.

ORS 142 K



Socket 143A



RS-Bus communication

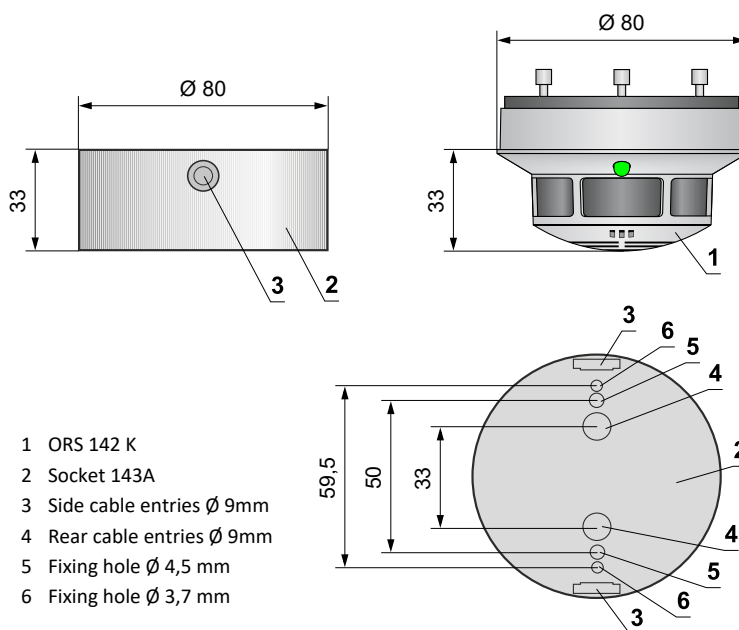
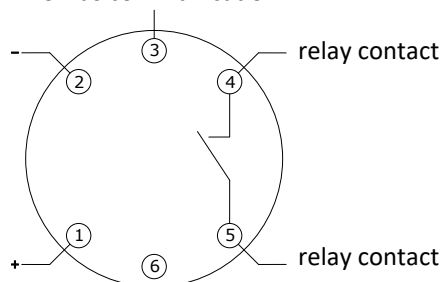

Relay contact		LED	
In operation		Green	Shines
Slight contamination		Green / Yellow	Flashes
Heavy contamination		Green / Yellow	Flashes
Fault		Yellow	Shines
Alarm		Red	Shines
Power Off		Off	-

Optical smoke detector ORS 142 K with the socket 143A

Operating voltage	18 ... 28 V DC
Residual ripple	≤ 200 mV
Power Consumption Socket (without actuator)	max. 22 mA
Degree of protection	IP 42
Ambient temperature	-20°C ... +75°C
Additional temperature sensor	+70°C
Connection - net	Cabel 1m, connected to terminals 1, 2 and 4
- motor	Actuator connected on the terminals 2 and 5
- communication and supply device BKN	Cabel 1m, connected to terminals 1, 2, 4 and 5

III. DIMENSIONS

FDMB with manual control

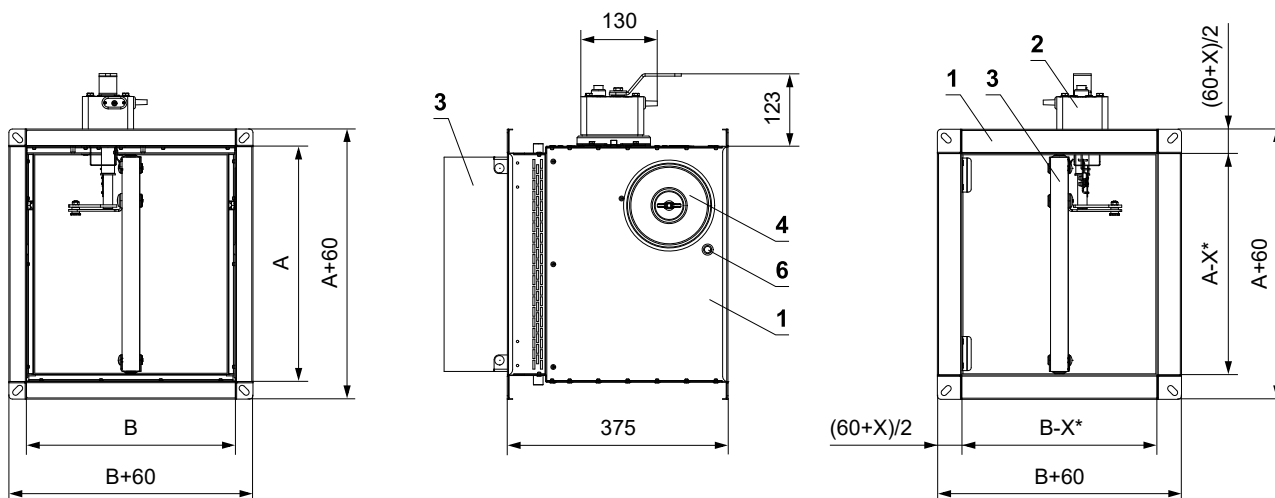

- * X=14 (A<160 or B<160)
- * X=23 (AxB≤500x400)
- * X=36 (AxB>500x400)

- 1 Damper casing
- 2 Manual control
- 3 Damper blade
- 4 Inspection opening cover
- 5 Sensor sticker
- 6 Hole for camera

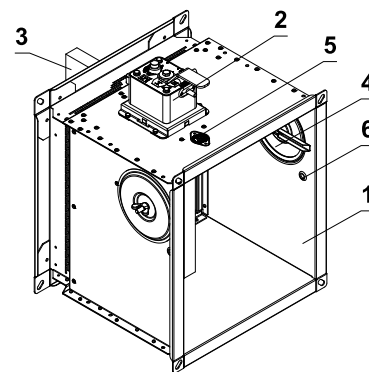
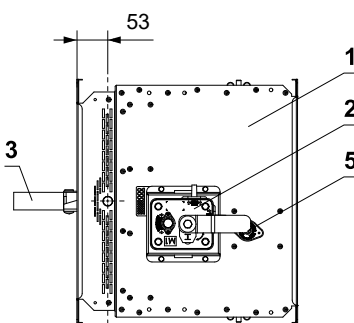

FDMB with spring return actuator

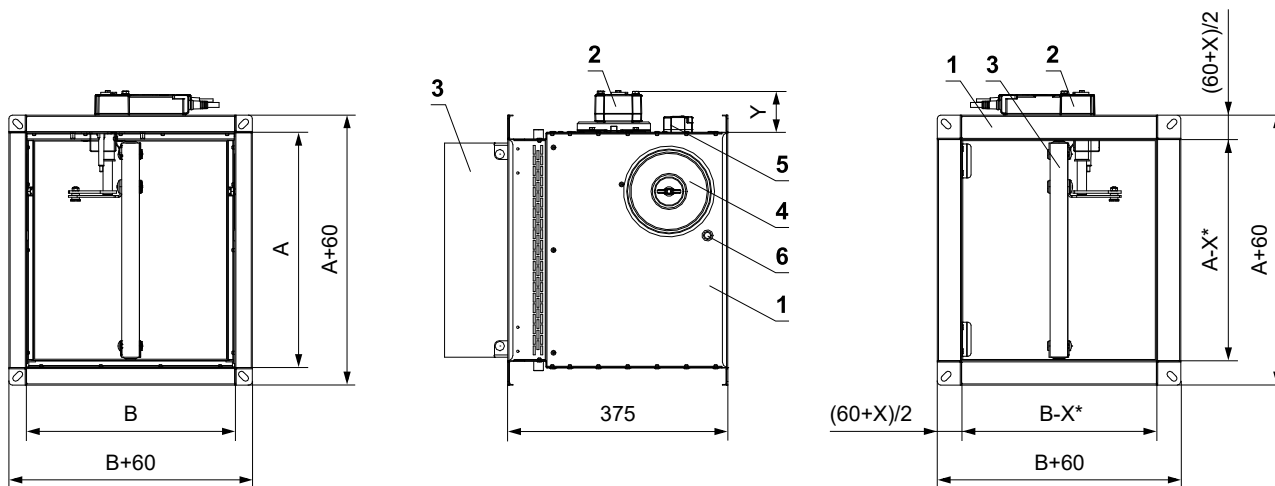

- * X=14 (A<160 or B<160) Y=72 mm (BFL)
- * X=23 (AxB≤500x400) Y=76 mm (BFN)
- * X=36 (AxB>500x400) Y=83 mm (BF)

- 1 Damper casing
- 2 Spring return actuator
- 3 Damper blade
- 4 Inspection opening cover
- 5 Thermoelectric activation device
- 6 Hole for camera

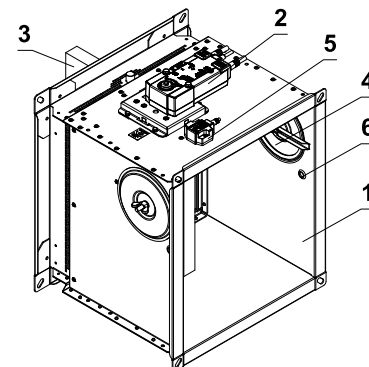
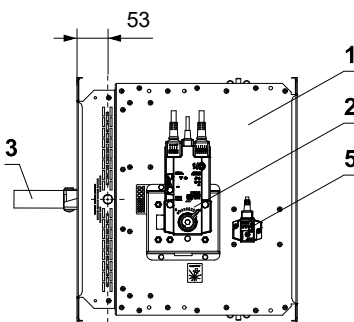

Damper blade overlaps

- Open damper blade overlaps the damper casing by the value "a" or "c". These values are specified in chapter Technical parameters → see pages 16 to 21

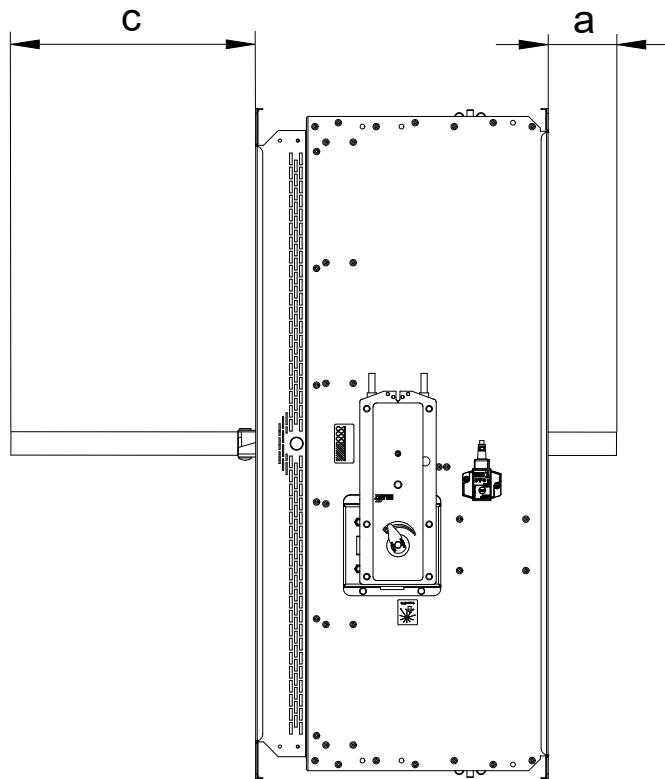

Values "a" and "c" has to be respected when projecting following air-conditioning duct.

Flange of a damper - CONTROL SIDE

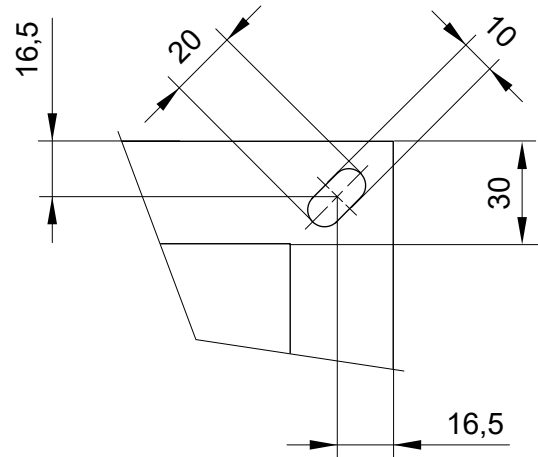

Flange of a damper - INSTALLATION SIDE

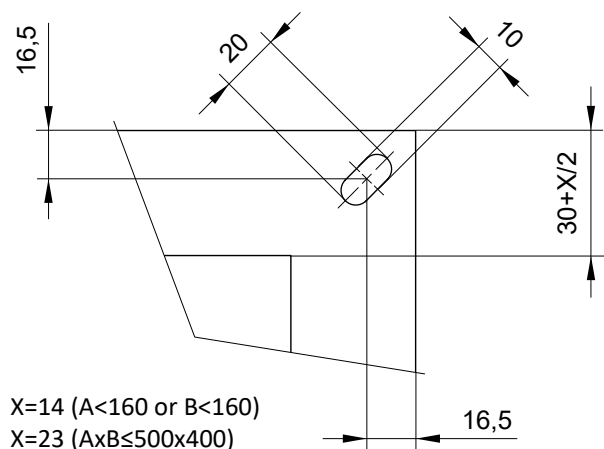

- X=14 (A<160 or B<160)
- X=23 (AxB≤500x400)
- X=36 (AxB>500x400)

30 mm wide flanges are fitted with oval holes in the corners

Technical parameters

A x B [mm]	Damper blade overlaps		Weight		Free area S _r [m ²]	Spring return actuator	Manual control	A x B [mm]	Damper blade overlaps		Weight		Free area S _r [m ²]	Spring return actuator	Manual control	
	a [mm]	c [mm]	Man. [kg]	Actu. [kg]*					a [mm]	c [mm]	Man. [kg]	Actu. [kg]*				
100 x	-	-	4,9	5,1	0,0030	BFL	M1	150 x	250	-	60	6,6	6,7	0,0234	BFL	M1
	-	-	4,9	5,1	0,0037				280	-	75	6,9	7	0,0271		
	-	-	5	5,2	0,0048				100	-	-	5,2	5,4	0,0055		
	-	5	5,1	5,3	0,0059				110	-	-	5,3	5,5	0,0069		
	-	10	5,2	5,4	0,0066				125	-	-	5,5	5,7	0,0088		
	-	15	5,2	5,4	0,0073				140	-	5	5,6	5,8	0,0108		
	-	25	5,4	5,6	0,0088				150	-	10	5,7	5,9	0,0121		
	-	35	5,5	5,7	0,0102				160	-	15	5,8	6	0,0113		
	-	47	5,7	5,8	0,0120				180	-	25	6	6,2	0,0137		
	-	60	5,8	6	0,0138				200	-	35	6,2	6,4	0,0161		
-	75	6	6,2	0,0160	225	-	47	6,5	6,6	0,0191	M1					
110 x	-	-	4,9	5,1	0,0034	BFL	M1	160 x	250	-		60	6,7	6,9	0,0222	BFL
	-	-	5	5,2	0,0043				280	-		75	7	7,1	0,0258	
	-	-	5,1	5,3	0,0055				300	-		85	7,2	7,3	0,0282	
	-	5	5,2	5,4	0,0067				315	-		92	7,4	7,5	0,0300	
	-	10	5,3	5,5	0,0075				355	-		112	7,7	7,9	0,0349	
	-	15	5,3	5,5	0,0084				400	-		135	8,2	8,3	0,0403	
	-	25	5,5	5,7	0,0100				450	-		150	8,6	8,7	0,0392	
	-	35	5,6	5,8	0,0116				500	-		175	9,1	9,2	0,0446	
	-	47	5,8	6	0,0137				550	-		200	9,6	9,7	0,0500	
	-	60	6	6,1	0,0157				560	-	205	9,7	9,7	0,0511		
-	75	6,2	6,3	0,0182	600	-	225	10	10,1	0,0554	M2					
125 x	-	-	5	5,2	0,0041	BFL	M1	1000	155	425		13,5	13,6	0,0986	BFN	
	-	-	5,1	5,3	0,0050				100	-		-	5,4	5,6		0,0064
	-	-	5,2	5,4	0,0065				110	-		-	5,5	5,7		0,0079
	-	5	5,3	5,5	0,0080				125	-		-	5,7	5,8		0,0102
	-	10	5,4	5,6	0,0089				140	-		5	5,8	6		0,0125
	-	15	5,5	5,7	0,0099				150	-		10	5,9	6,1		0,0140
	-	25	5,7	5,8	0,0118				160	-		15	6	6,2		0,0131
	-	35	5,8	6	0,0138				180	-		25	6,3	6,4		0,0159
	-	47	6	6,2	0,0162				200	-		35	6,5	6,6		0,0187
	-	60	6,2	6,3	0,0186				225	-	47	6,8	6,9	0,0222		
-	75	6,4	6,6	0,0215	250	-	60	7	7,2	0,0258	M1					
140 x	-	-	5,1	5,3	0,0047	BFL	M1	180 x	300	-		85	7,6	7,7	0,0328	BFL
	-	-	5,2	5,4	0,0058				315	-		92	7,7	7,8	0,0349	
	-	-	5,3	5,5	0,0075				355	-		112	8,2	8,3	0,0406	
	-	5	5,5	5,6	0,0092				400	-		135	8,6	8,7	0,0469	
	-	10	5,6	5,7	0,0103				450	-		150	9,2	9,3	0,0465	
	-	15	5,6	5,8	0,0114				500	-		175	9,7	9,8	0,0529	
	-	25	5,8	6	0,0137				550	-		200	10,2	10,3	0,0593	
	-	35	6	6,2	0,0159				560	-		205	10,3	10,4	0,0605	
	-	47	6,2	6,4	0,0187				600	-		225	10,7	10,8	0,0657	
	-	60	6,4	6,6	0,0215				630	-	240	11	11,1	0,0695		
-	75	6,7	6,8	0,0249	650	-	250	11,2	11,3	0,0721	M2					
150 x	-	-	5,2	5,4	0,0051	BFL	M1	700	5	275		11,7	11,8	0,0785	BFN	
	-	-	5,3	5,5	0,0063				100	-		-	5,4	5,6		0,0064
	-	-	5,4	5,6	0,0082				110	-		-	5,5	5,7		0,0079
	-	5	5,6	5,7	0,0100				125	-		-	5,7	5,8		0,0102
	-	10	5,7	5,8	0,0112				140	-		5	5,8	6		0,0125
	-	15	5,7	5,9	0,0124				150	-		10	5,9	6,1		0,0140
	-	25	5,9	6,1	0,0149				160	-		15	6	6,2		0,0131
	-	35	6,1	6,3	0,0173				180	-		25	6,3	6,4		0,0159
	-	47	6,4	6,5	0,0204				200	-		35	6,5	6,6		0,0187
	-	60	6,4	6,6	0,0215				225	-	47	6,8	6,9	0,0222		

Sizes in increments of 5 mm can be manufactured on request.

* For designs with BKN a weight of 0.5 kg must be added.

A x B [mm]	Damper blade overlaps		Weight		Free area Sf [m²]	Spring return actuator	Manual control	A x B [mm]	Damper blade overlaps		Weight		Free area Sf [m²]	Spring return actuator	Manual control	
	a [mm]	c [mm]	Man. [kg]	Actu. [kg]*					a [mm]	c [mm]	Man. [kg]	Actu. [kg]*				
180 x	710	10	280	11,8	11,9	0,0797	BFN	M2	710	10	280	13,5	13,6	0,1078	BFN	M2
	750	30	300	12,2	12,3	0,0849			750	30	300	14	14,1	0,1147		
	800	55	325	12,7	12,8	0,0913			800	55	325	14,6	14,7	0,1233		
	900	105	375	13,6	13,7	0,1041			900	105	375	15,7	15,9	0,1406		
	1000	155	425	14,6	14,7	0,1169			1000	155	425	16,8	17	0,1579		
200 x	100	-	-	5,5	5,7	0,0072	BFL	M1	100	-	-	5,8	6	0,0093	BFL	M1
	110	-	-	5,6	5,8	0,0089			110	-	-	6	6,1	0,0115		
	125	-	-	5,8	6	0,0115			125	-	-	6,2	6,3	0,0149		
	140	-	5	6	6,2	0,0141			140	-	5	6,4	6,6	0,0182		
	150	-	10	6,1	6,3	0,0158			150	-	10	6,6	6,7	0,0204		
	160	-	15	6,2	6,4	0,0149			160	-	15	6,7	6,9	0,0194		
	180	-	25	6,5	6,6	0,0181			180	-	25	7	7,2	0,0236		
	200	-	35	6,7	6,9	0,0213			200	-	35	7,3	7,5	0,0278		
	225	-	47	7	7,2	0,0253			225	-	47	7,7	7,8	0,0331		
	250	-	60	7,3	7,5	0,0294			250	-	60	8,1	8,2	0,0384		
	280	-	75	7,7	7,8	0,0342	280	-	75	8,5	8,6	0,0447				
	300	-	85	7,9	8	0,0374	300	-	85	8,8	8,9	0,0489				
	315	-	92	8,1	8,2	0,0398	315	-	92	9	9,1	0,0521				
	355	-	112	8,6	8,7	0,0463	355	-	112	9,6	9,7	0,0605				
	400	-	135	9,1	9,2	0,0535	400	-	135	10,3	10,3	0,0700				
	450	-	150	9,7	9,8	0,0537	450	-	150	11	11,1	0,0719				
	500	-	175	10,3	10,3	0,0611	500	-	175	11,7	11,7	0,0818				
	550	-	200	10,8	10,9	0,0685	550	-	200	12,3	12,4	0,0917				
	560	-	205	10,9	11	0,0700	560	-	205	12,5	12,6	0,0937				
	600	-	225	11,4	11,5	0,0759	600	-	225	13	13,1	0,1016				
630	-	240	11,7	11,8	0,0804	630	-	240	13,4	13,5	0,1075					
650	-	250	11,9	12	0,0833	650	-	250	13,7	13,8	0,1115					
700	5	275	12,5	12,6	0,0907	700	5	275	14,3	14,4	0,1214					
710	10	280	12,6	12,7	0,0922	710	10	280	14,4	14,6	0,1234					
750	30	300	13	13,1	0,0981	750	30	300	14,9	15,1	0,1313					
800	55	325	13,5	13,6	0,1055	800	55	325	15,6	15,7	0,1412					
900	105	375	14,6	14,7	0,1203	900	105	375	16,8	17	0,1610					
1000	155	425	15,6	15,7	0,1351	1000	155	425	17,9	18,3	0,1808					
225 x	100	-	-	5,7	5,8	0,0083	BFL	M1	100	-	-	6	6,2	0,0106	BFL	M1
	110	-	-	5,8	6	0,0102			110	-	-	6,2	6,3	0,0131		
	125	-	-	6	6,2	0,0132			125	-	-	6,4	6,6	0,0169		
	140	-	5	6,2	6,4	0,0162			140	-	5	6,7	6,8	0,0207		
	150	-	10	6,4	6,5	0,0181			150	-	10	6,9	7	0,0232		
	160	-	15	6,5	6,6	0,0171			160	-	15	7	7,1	0,0221		
	180	-	25	6,8	6,9	0,0209			180	-	25	7,4	7,5	0,0269		
	200	-	35	7	7,2	0,0246			200	-	35	7,7	7,8	0,0317		
	225	-	47	7,4	7,5	0,0292			225	-	47	8,1	8,2	0,0377		
	250	-	60	7,7	7,8	0,0339			250	-	60	8,5	8,6	0,0438		
	280	-	75	8,1	8,2	0,0395	280	-	75	9	9,1	0,0510				
	300	-	85	8,4	8,5	0,0432	300	-	85	9,3	9,4	0,0558				
	315	-	92	8,6	8,7	0,0460	315	-	92	9,6	9,7	0,0594				
	355	-	112	9,1	9,2	0,0534	355	-	112	10,2	10,3	0,0691				
	400	-	135	9,7	9,8	0,0618	400	-	135	10,9	11	0,0799				
	450	-	150	10,3	10,4	0,0628	450	-	150	11,7	11,8	0,0828				
	500	-	175	11	11,1	0,0714	500	-	175	12,5	12,6	0,0942				
	550	-	200	11,6	11,7	0,0801	550	-	200	13,2	13,3	0,1056				
	560	-	205	11,7	11,8	0,0818	560	-	205	13,4	13,5	0,1078				
	600	-	225	12,2	12,3	0,0887	600	-	225	13,9	14,1	0,1170				
630	-	240	12,6	12,6	0,0939	630	-	240	14,4	14,5	0,1238					
650	-	250	12,8	12,9	0,0974	650	-	250	14,7	14,8	0,1284					
700	5	275	13,4	13,5	0,1060	700	5	275	15,4	15,5	0,1398					

Sizes in increments of 5 mm can be manufactured on request.

* For designs with BKN a weight of 0.5 kg must be added.

A x B [mm]	Damper blade overlaps		Weight		Free area S _f [m ²]	Spring return actuator	Manual control	A x B [mm]	Damper blade overlaps		Weight		Free area S _f [m ²]	Spring return actuator	Manual control	
	a	c	Man.	Actu.					a	c	Man.	Actu.				
	[mm]	[mm]	[kg]	[kg]*					[mm]	[mm]	[kg]	[kg]*				
280 x	710	10	280	15,5	15,7	0,1420	BFN	M2	710	10	280	16,7	17	0,1638	BFN	M2
	750	30	300	16	16,3	0,1512			750	30	300	17,3	17,6	0,1744		
	800	55	325	16,7	17	0,1626	BF	M3	800	55	325	18	18,4	0,1875	BF	M3
	900	105	375	18	18,4	0,1854			900	105	375	19,4	19,9	0,2138		
	1000	155	425	19,3	19,8	0,2082			1000	155	425	20,7	21,4	0,2401		
300 x	100	-	-	6,1	6,3	0,0114	BFL	M1	100	-	-	6,5	6,6	0,0137	BFL	M1
	110	-	-	6,3	6,4	0,0141			110	-	-	6,7	6,8	0,0170		
	125	-	-	6,6	6,7	0,0182			125	-	-	7	7,1	0,0219		
	140	-	5	6,9	7	0,0223			140	-	5	7,3	7,4	0,0268		
	150	-	10	7	7,2	0,0250			150	-	10	7,5	7,6	0,0301		
	160	-	15	7,2	7,3	0,0239			160	-	15	7,7	7,9	0,0288		
	180	-	25	7,6	7,7	0,0291			180	-	25	8,2	8,3	0,0352		
	200	-	35	7,9	8	0,0343			200	-	35	8,6	8,7	0,0415		
	225	-	47	8,4	8,5	0,0408			225	-	47	9,1	9,2	0,0494		
	250	-	60	8,8	8,9	0,0474			250	-	60	9,6	9,7	0,0573		
	280	-	75	9,3	9,4	0,0552	280	-	75	10,2	10,3	0,0668				
	300	-	85	9,7	9,8	0,0604	300	-	85	10,6	10,7	0,0731				
	315	-	92	10,0	10,1	0,0643	315	-	92	10,9	11	0,0778				
	355	-	112	10,6	10,7	0,0748	355	-	112	11,7	11,8	0,0905				
	400	-	135	11,4	11,5	0,0865	400	-	135	12,6	12,7	0,1047				
	450	-	150	12,2	12,3	0,0900	450	-	150	13,5	13,6	0,1100				
	500	-	175	13	13,1	0,1024	500	-	175	14,4	14,6	0,1251				
	550	-	200	13,8	13,9	0,1148	550	-	200	15,3	15,5	0,1403				
	560	-	205	13,9	14,1	0,1173	560	-	205	15,5	15,7	0,1433				
	600	-	225	14,6	14,7	0,1272	600	-	225	16,2	16,4	0,1554				
630	-	240	15	15,2	0,1347	630	-	240	16,7	17	0,1645					
650	-	250	15,3	15,5	0,1396	650	-	250	17	17,3	0,1706					
700	5	275	16	16,3	0,1520	700	5	275	17,9	18,2	0,1857					
710	10	280	16,2	16,4	0,1545	710	10	280	18	18,4	0,1888					
750	30	300	16,8	17	0,1644	750	30	300	18,7	19,1	0,2009					
800	55	325	17,5	17,8	0,1768	800	55	325	19,4	20	0,2160					
900	105	375	18,8	19,3	0,2016	900	105	375	20,9	21,6	0,2463					
1000	155	425	20,1	20,7	0,2264	1000	155	425	22,3	23,3	0,2766					
315 x	100	-	-	6,2	6,4	0,0121	BFL	M1	100	-	-	6,7	6,9	0,0156	BFL	M1
	110	-	-	6,4	6,5	0,0149			110	-	-	7	7,1	0,0193		
	125	-	-	6,7	6,8	0,0192			125	-	-	7,3	7,5	0,0249		
	140	-	5	7	7,1	0,0235			140	-	5	7,7	7,8	0,0305		
	150	-	10	7,2	7,3	0,0264			150	-	10	7,9	8	0,0342		
	160	-	15	7,4	7,5	0,0252			160	-	15	8,2	8,3	0,0329		
	180	-	25	7,7	7,8	0,0308			180	-	25	8,6	8,7	0,0401		
	200	-	35	8,1	8,2	0,0363			200	-	35	9,1	9,2	0,0473		
	225	-	47	8,6	8,7	0,0432			225	-	47	9,7	9,8	0,0563		
	250	-	60	9	9,1	0,0501			250	-	60	10,3	10,3	0,0654		
	280	-	75	9,6	9,7	0,0584	280	-	75	10,9	11	0,0762				
	300	-	85	10	10,1	0,0639	300	-	85	11,4	11,5	0,0834				
	315	-	92	10,2	10,3	0,0680	315	-	92	11,7	11,8	0,0888				
	355	-	112	10,9	11	0,0791	355	-	112	12,6	12,7	0,1033				
	400	-	135	11,7	11,8	0,0915	400	-	135	13,5	13,6	0,1195				
	450	-	150	12,6	12,6	0,0955	450	-	150	14,6	14,7	0,1263				
	500	-	175	13,4	13,5	0,1086	500	-	175	15,6	15,7	0,1437				
	550	-	200	14,2	14,3	0,1218	550	-	200	16,5	16,8	0,1611				
	560	-	205	14,4	14,5	0,1244	560	-	205	16,7	17	0,1646				
	600	-	225	15	15,2	0,1349	600	-	225	17,5	17,8	0,1785				
630	-	240	15,5	15,7	0,1428	630	-	240	18	18,4	0,1890					
650	-	250	15,8	16	0,1481	650	-	250	18,4	18,8	0,1959					
700	5	275	16,6	16,8	0,1612	700	5	275	19,3	19,8	0,2133					

Sizes in increments of 5 mm can be manufactured on request.

* For designs with BKN a weight of 0.5 kg must be added.

A x B [mm]	Damper blade overlaps		Weight		Free area Sf [m²]	Spring return actuator	Manual control	A x B [mm]	Damper blade overlaps		Weight		Free area Sf [m²]	Spring return actuator	Manual control		
	a [mm]	c [mm]	Man. [kg]	Actu. [kg]*					a [mm]	c [mm]	Man. [kg]	Actu. [kg]*					
400 x	710	10	280	19,4	20	0,2168	BFN	M2	500 x 1000	125	-	-	8,5	8,5	0,0350	BF	M3
	750	30	300	20,1	20,7	0,2307	140	-		5	8,9	9	0,0428				
	800	55	325	20,9	21,7	0,2481	150	-		10	9,3	9,3	0,0480				
	900	105	375	22,5	23,5	0,2829	160	-		15	9,6	9,7	0,0364				
	1000	155	425	23,9	25,2	0,3177	180	-		25	10,2	10,3	0,0463				
	125	-	-	7,7	7,8	0,0283	BFL	M1	200	-	35	10,8	10,9	0,0563			
	140	-	5	8,1	8,2	0,0346			225	-	47	11,6	11,7	0,0687			
	150	-	10	8,4	8,5	0,0388			250	-	60	12,3	12,4	0,0812			
	160	-	15	8,6	8,7	0,0374			280	-	75	13,2	13,3	0,0961			
	180	-	25	9,2	9,3	0,0456			300	-	85	13,8	13,9	0,1061			
	200	-	35	9,7	9,8	0,0538			315	-	92	14,2	14,3	0,1135			
	225	-	47	10,3	10,4	0,0641			355	-	112	15,3	15,5	0,1335			
	250	-	60	11	11,1	0,0744			550 x	400	-	135	16,5	16,8	0,1559		
	280	-	75	11,7	11,8	0,0867				450	-	150	17,8	18,2	0,1808		
	300	-	85	12,2	12,3	0,0949				500	-	175	19	19,5	0,2057		
315	-	92	12,6	12,6	0,1011	550	-	200		20,2	20,8	0,2306					
355	-	112	13,5	13,6	0,1175	560	-	205		20,5	21,1	0,2356					
450 x	400	-	135	14,6	14,7	0,1360	BFN	M2	600	-	225	21,3	22,1	0,2555			
	450	-	150	15,7	15,9	0,1445			630	-	240	22	22,9	0,2704			
	500	-	175	16,8	17	0,1644			650	-	250	22,4	23,4	0,2804			
	550	-	200	17,8	18,2	0,1843			700	5	275	23,4	24,6	0,3053			
	560	-	205	18	18,4	0,1883			710	10	280	23,6	24,8	0,3103			
	600	-	225	18,8	19,3	0,2042			750	30	300	24,4	25,8	0,3302			
	630	-	240	19,4	19,9	0,2161			800	55	325	25,3	26,9	0,3551			
	650	-	250	19,8	20,4	0,2241			900	105	375	26,9	29,1	0,4049			
	700	5	275	20,7	21,4	0,2440			560 x	125	-	-	8,5	8,6	0,0356		
	710	10	280	20,9	21,6	0,2480				140	-	5	9	9,1	0,0436		
750	30	300	21,6	22,5	0,2639	150	-	10		9,3	9,4	0,0489					
800	55	325	22,5	23,5	0,2838	160	-	15		9,7	9,7	0,0371					
900	105	375	24,1	25,4	0,3236	180	-	25		10,3	10,4	0,0472					
1000	155	425	25,6	27,3	0,3634	200	-	35		10,9	11	0,0574					
500 x	125	-	-	8,1	8,2	0,0316	BFL	M1		225	-	47	11,7	11,8	0,0701		
	140	-	5	8,5	8,6	0,0387				250	-	60	12,5	12,6	0,0828		
	150	-	10	8,8	8,9	0,0434				280	-	75	13,4	13,5	0,0980		
	160	-	15	9,1	9,2	0,0419				300	-	85	13,9	14,1	0,1082		
	180	-	25	9,7	9,8	0,0511			315	-	92	14,4	14,5	0,1158			
	200	-	35	10,3	10,3	0,0603			355	-	112	15,5	15,7	0,1361			
	225	-	47	11	11,1	0,0718			400	-	135	16,7	17	0,1590			
	250	-	60	11,7	11,7	0,0834			450	-	150	18	18,4	0,1844			
	280	-	75	12,5	12,6	0,0972			500	-	175	19,3	19,8	0,2098			
	300	-	85	13	13,1	0,1064			550	-	200	20,5	21,1	0,2352			
	315	-	92	13,4	13,5	0,1133	BFN	M2	560	-	205	20,7	21,4	0,2403			
	355	-	112	14,4	14,6	0,1318			600	-	225	21,6	22,4	0,2606			
	400	-	135	15,6	15,7	0,1525			630	-	240	22,2	23,2	0,2758			
	450	-	150	16,8	17	0,1626			650	-	250	22,7	23,7	0,2860			
	500	-	175	17,9	18,3	0,1850			700	5	275	23,7	24,9	0,3114			
	550	-	200	19	19,5	0,2074			710	10	280	23,9	25,1	0,3165			
	560	-	205	19,3	19,8	0,2119			750	30	300	24,6	26,1	0,3368			
	600	-	225	20,1	20,7	0,2298			800	55	325	25,5	27,2	0,3622			
	630	-	240	20,7	21,4	0,2433			600 x	140	-	5	9,3	9,4	0,0469		
	650	-	250	21,1	21,9	0,2522				150	-	10	9,7	9,8	0,0526		
700	5	275	22,1	23	0,2746	160	-	15		10	10,1	0,0400					
710	10	280	22,3	23,3	0,2791	180	-	25		10,7	10,8	0,0510					
750	30	300	23,1	24,1	0,2970	200	-	35		11,4	11,5	0,0619					
800	55	325	23,9	25,2	0,3194	225	-	47	12,2	12,3	0,0756						
900	105	375	25,6	27,3	0,3642												

Sizes in increments of 5 mm can be manufactured on request.

* For designs with BKN a weight of 0.5 kg must be added.

A x B [mm]	Damper blade overlaps		Weight		Free area S _f [m ²]	Spring return actuator	Manual control	A x B [mm]	Damper blade overlaps		Weight		Free area S _f [m ²]	Spring return actuator	Manual control				
	a [mm]	c [mm]	Man. [kg]	Actu. [kg]*					a [mm]	c [mm]	Man. [kg]	Actu. [kg]*							
600 x	250	-	60	13	13,1	0,0893	BFL	M1	630	-	240	24,3	25,6	0,3247	BF	M2			
	280	-	75	13,9	14,1	0,1058			650 x	650	-	250	24,7	26,2			0,3367		
	300	-	85	14,6	14,7	0,1167			700	5	275	25,7	27,5	0,3666					
	315	-	92	15	15,2	0,1249			710	10	280	25,9	27,8	0,3726					
	355	-	112	16,2	16,4	0,1469			750	30	300	26,7	28,8	0,3965					
	400	-	135	17,5	17,8	0,1715			700 x	150	-	10	10,5	10,6			0,0618	BFL	M2
	450	-	150	18,8	19,3	0,1989				160	-	15	10,9	11			0,0473		
	500	-	175	20,1	20,7	0,2263				180	-	25	11,7	11,8			0,0603		
	550	-	200	21,3	22,1	0,2537				200	-	35	12,5	12,6			0,0732		
	560	-	205	21,6	22,4	0,2592				225	-	47	13,4	13,5			0,0894		
	600	-	225	22,5	23,5	0,2811				250	-	60	14,3	14,4			0,1056		
	630	-	240	23,2	24,3	0,2976				280	-	75	15,4	15,5			0,1251		
	650	-	250	23,6	24,8	0,3085				300	-	85	16	16,3			0,1380		
	700	5	275	24,6	26,1	0,3359				315	-	92	16,6	16,8			0,1477		
	710	10	280	24,8	26,3	0,3414				355	-	112	17,9	18,2			0,1737		
	750	30	300	25,6	27,3	0,3633				400	-	135	19,3	19,8			0,2028		
800	55	325	26,5	28,5	0,3907	450	-	150		20,7	21,4	0,2352							
630 x	140	-	5	9,6	9,7	0,0494	500	-		175	22,1	23	0,2676						
	150	-	10	10	10,1	0,0554	550	-		200	23,4	24,6	0,3000						
	160	-	15	10,3	10,4	0,0422	560	-		205	23,7	24,9	0,3065						
	180	-	25	11	11,1	0,0538	600	-		225	24,6	26,1	0,3324						
	200	-	35	11,7	11,8	0,0653	630	-	240	25,3	26,9	0,3519							
	225	-	47	12,6	12,6	0,0798	650	-	250	25,7	27,5	0,3648							
	250	-	60	13,4	13,5	0,0942	700	5	275	26,8	28,9	0,3972							
	280	-	75	14,4	14,5	0,1116	710	10	280	27	29,2	0,4037							
	300	-	85	15	15,2	0,1231	710 x	150	-	10	10,6	10,7	0,0627						
	315	-	92	15,5	15,7	0,1318		160	-	15	11	11,1	0,0480						
	355	-	112	16,7	17	0,1549		180	-	25	11,8	11,9	0,0612						
	400	-	135	18	18,4	0,1809		200	-	35	12,6	12,7	0,0744						
	450	-	150	19,4	19,9	0,2098		225	-	47	13,5	13,6	0,0908						
	500	-	175	20,7	21,4	0,2387		250	-	60	14,4	14,6	0,1073						
	550	-	200	22	22,9	0,2676		280	-	75	15,5	15,7	0,1270						
	560	-	205	22,2	23,2	0,2734		300	-	85	16,2	16,4	0,1402						
600	-	225	23,2	24,3	0,2965	315		-	92	16,7	17	0,1500							
630	-	240	23,8	25,1	0,3139	355		-	112	18	18,4	0,1763							
650	-	250	24,3	25,6	0,3254	400		-	135	19,4	20	0,2060							
700	5	275	25,3	26,9	0,3543	450		-	150	20,9	21,6	0,2389							
710	10	280	25,5	27,2	0,3601	500		-	175	22,3	23,3	0,2718							
750	30	300	26,3	28,2	0,3832	550		-	200	23,6	24,8	0,3047							
650 x	140	-	5	9,8	9,8	0,0510		560	-	205	23,9	25,1	0,3112						
	150	-	10	10,1	10,2	0,0572		600	-	225	24,8	26,3	0,3376						
	160	-	15	10,5	10,6	0,0437	630	-	240	25,5	27,2	0,3573							
	180	-	25	11,2	11,3	0,0556	650	-	250	25,9	27,8	0,3705							
	200	-	35	11,9	12	0,0676	700	5	275	27	29,2	0,4034							
	225	-	47	12,8	12,9	0,0825	750 x	150	-	10	11	11,1	0,0664						
	250	-	60	13,7	13,8	0,0975		160	-	15	11,4	11,5	0,0510						
	280	-	75	14,7	14,8	0,1154		180	-	25	12,2	12,3	0,0649						
	300	-	85	15,3	15,5	0,1274		200	-	35	13	13,1	0,0789						
	315	-	92	15,8	16	0,1363		225	-	47	14	14,1	0,0963						
	355	-	112	17	17,3	0,1603		250	-	60	14,9	15,1	0,1138						
	400	-	135	18,4	18,8	0,1872		280	-	75	16	16,3	0,1347						
	450	-	150	19,8	20,4	0,2171		300	-	85	16,8	17	0,1487						
	500	-	175	21,1	21,9	0,2470		315	-	92	17,3	17,6	0,1591						
	550	-	200	22,4	23,4	0,2769		355	-	112	18,7	19,1	0,1871						
	560	-	205	22,7	23,7	0,2829		400	-	135	20,1	20,7	0,2185						
600	-	225	23,6	24,8	0,3068	450		-	150	21,6	22,5	0,2534							

Sizes in increments of 5 mm can be manufactured on request.

* For designs with BKN a weight of 0.5 kg must be added.

A x B [mm]	Damper blade overlaps		Weight		Free area S _f [m ²]	Spring return actuator	Manual control	A x B [mm]	Damper blade overlaps		Weight		Free area S _f [m ²]	Spring return actuator	Manual control
	a [mm]	c [mm]	Man. [kg]	Actu. [kg]*					a [mm]	c [mm]	Man. [kg]	Actu. [kg]*			
750 x	500	-	175	23,1	24,1	0,2883	BFN	900 x	200	-	35	14,6	14,7	0,0958	
	550	-	200	24,4	25,8	0,3232			225	-	47	15,7	15,9	0,1170	
	560	-	205	24,6	26,1	0,3302			250	-	60	16,8	17	0,1382	BFL
	600	-	225	25,6	27,3	0,3581	BF		280	-	75	18	18,4	0,1637	
	630	-	240	26,3	28,2	0,3790			300	-	85	18,8	19,3	0,1806	
	650	-	250	26,7	28,8	0,3930			315	-	92	19,4	19,9	0,1933	
800 x	150	-	10	11,4	11,5	0,0710		355	-	112	20,9	21,6	0,2273		
	160	-	15	11,8	11,9	0,0546		400	-	135	22,5	23,5	0,2654	BFN	
	180	-	25	12,7	12,8	0,0696		450	-	150	24,1	25,4	0,3078		
	200	-	35	13,5	13,6	0,0845		500	-	175	25,6	27,3	0,3502	BF	
	225	-	47	14,6	14,7	0,1032	BFL	550	-	200	26,9	29,1	0,3926		
	250	-	60	15,6	15,7	0,1219		1000 x	160	-	15	13,5	13,6	0,0692	
	280	-	75	16,7	17	0,1444			180	-	25	14,6	14,7	0,0882	
	300	-	85	17,5	17,8	0,1593			200	-	35	15,6	15,7	0,1071	
	315	-	92	18	18,4	0,1705	M2		225	-	47	16,8	17	0,1308	BFL
	355	-	112	19,4	20	0,2005			250	-	60	17,9	18,3	0,1545	
400	-	135	20,9	21,7	0,2341	BFN	280		-	75	19,3	19,8	0,1830		
450	-	150	22,5	23,5	0,2715		300	-	85	20,1	20,7	0,2019			
500	-	175	23,9	25,2	0,3089		315	-	92	20,7	21,4	0,2161			
550	-	200	25,3	26,9	0,3463		355	-	112	22,3	23,3	0,2541	BFN		
560	-	205	25,5	27,2	0,3538	BF	400	-	135	23,9	25,2	0,2967			
600	-	225	26,5	28,5	0,3837		450	-	150	25,6	27,3	0,3441			
900 x	160	-	15	12,7	12,8	0,0619	BFL	500	-	175	27	29,3	0,3915	BF	
	180	-	25	13,6	13,7	0,0789	M2								

Sizes in increments of 5 mm can be manufactured on request.

* For designs with BKN a weight of 0.5 kg must be added.

IV. INSTALLATION

Placement and installation

- The fire dampers are suitable for installation in arbitrary position in vertical and horizontal passages of fire separating constructions. The damper installation procedures must be done so that all load transfer from the fire separating constructions to the damper is absolutely excluded. Following air-conditioning duct must be suspended or supported so that all load transfer from the following duct to the fire damper is absolutely excluded. The gap between the installed damper and the fire separating construction must be perfectly filled with approved material.
- The damper must be installed so that the damper blade (in closed position) is situated in the fire separating construction - marked by the label BUILT-IN EDGE on the damper casing. If such solution is not possible, the duct between the fire separating construction and the damper blade must be protected according to the certified installation method → see pages 25 to 72
- During the installation and plastering process, the actuating mechanism must be protected (covered) against damage and pollution. The damper casing should not be deformed during bricking in. Once the damper is built in, the damper blade should not grind against the damper casing during opening or closing.
- The distance between the fire damper and the construction (wall, ceiling) must be 75 mm at the minimum, according to EN 1366-2. If two or more dampers are to be installed in one fire separating construction, the distance between adjacent dampers must be 200 mm at the minimum, according to EN 1366-2.
- Fire dampers can be installed without following duct on one or both sides. Installation without following duct is only possible in vertical constructions. In this case, the fire dampers must be installed with cover grilles (additional extension parts may be required due to overlapping of the damper blade → see pages 16 to 21). The damper must be installed so that the activation device (thermal fuse/thermoelectric activation device/smoke detector) is located at the highest possible point of the damper (top of the casing).

Minimum distance between the fire dampers and the construction

- minimum distance 200 mm between dampers, according to EN 1366-2
- minimum distance 75 mm between damper and construction (wall/ceiling), according to EN 1366-2
- recommended minimum distance 150 mm necessary for access to the actuator
- recommended minimum distance 250 mm necessary for access to the manual control

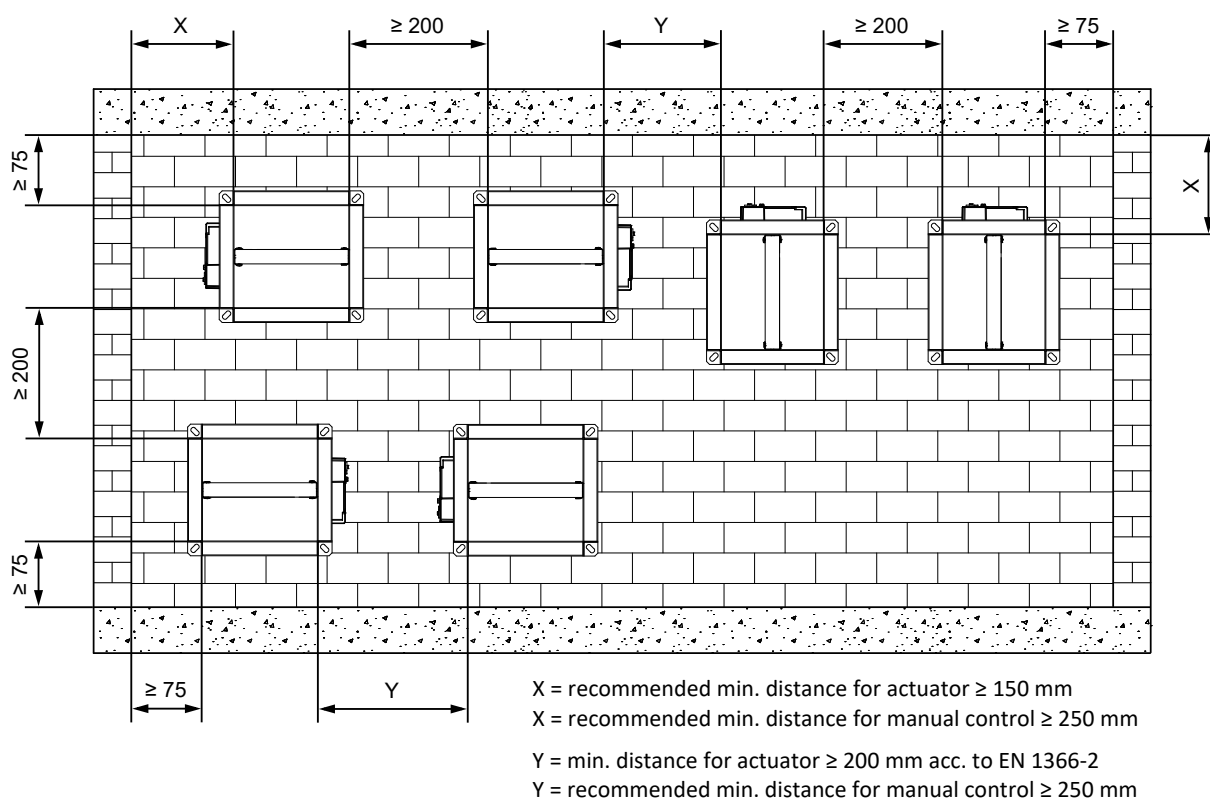

Built in edge

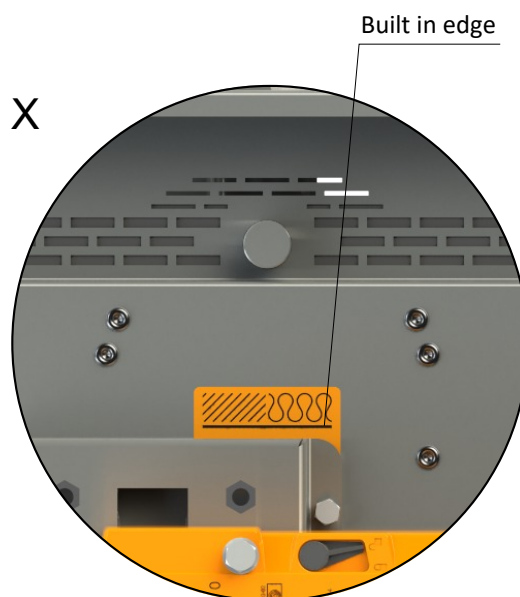
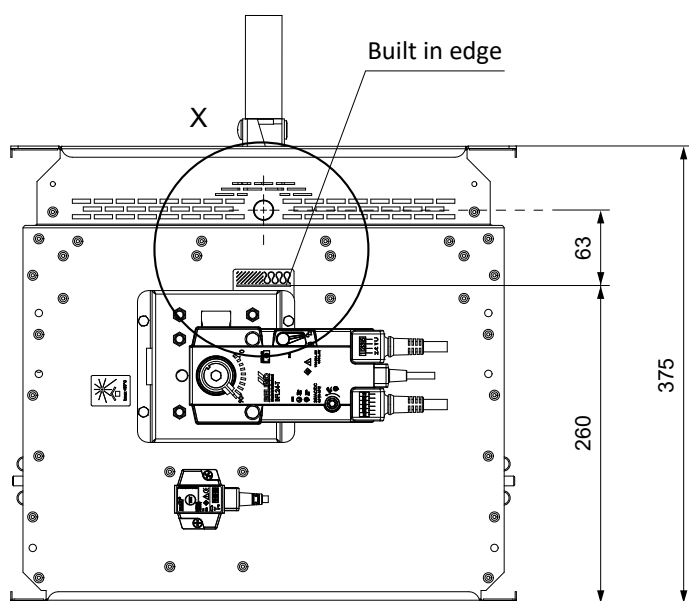

Dimensions of an installation opening

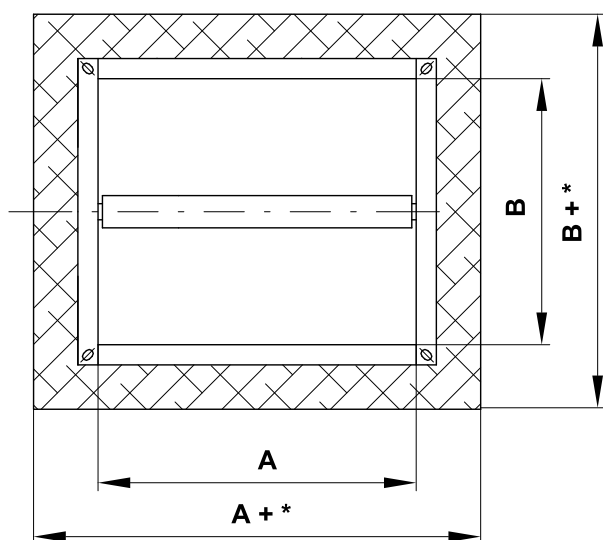

*** Mortar or gypsum**

- min. A(B)+100
- max. A(B)+300

*** Stuffing box with fire protective boards**

- min. A(B)+80
- max. A(B)+150

*** Stuffing box with fire protective boards, damper outside construction**

- A(B)+100 mm for max. fire resistance of the installation EI 120 S
- min. A(B)+80 for max. fire resistance of the installation EI 90 S
- max. A(B)+150 for max. fire resistance of the installation EI 90 S

*** Ablative Coated Batt, damper in solid/CLT/ceiling/CLT ceiling construction**

- min. A(B)+80
- max. A(B)+400

*** Ablative Coated Batt, damper in gypsum wall construction min. EI 90**

- min. A(B)+80
- max. A(B)+400

*** Ablative Coated Batt, damper in gypsum wall construction min. EI 60**

- min. A(B)+80
- max. A(B)+260

*** Ablative Coated Batt, damper in gypsum wall construction min. EI 30**

- min. A(B)+80
- max. A(B)+310

*** Ablative Coated Batt, damper outside construction EI 90**

- min. A(B)+80
- max. A(B)+200

*** Ablative Coated Batt, damper outside construction EI 60**

- min. A(B)+80
- max. A(B)+150

*** Ablative Coated Batt, damper in shaft wall construction**

- A(B)+100^{+0/-20} for max. fire resistance of the installation EI 90 S
- min. A(B)+80 for max. fire resistance of the installation EI 60 S
- max. A(B)+260 for max. fire resistance of the installation EI 60 S

Statement of installations

Fire separating construction, location of the damper	Installation type, installation system	Gap width [mm]	Fire resistance	Page
Standard low- and high-density rigid wall construction according to EN 1363-1 <ul style="list-style-type: none"> damper in the wall 100 mm min. wall thickness 	Mortar or gypsum	50–150	EI 120 (v _e) S [V/H] *	25
	2 dampers in battery - Mortar or gypsum	50–150	EI 90 (v _e) S [H]	26
	Stuffing box with fire protective boards	40–75		28
	Installation frame E1, E4	N/A	EI 90 (v _e) S [V/H]	56, 65
	Installation frame E2 - Mortar or gypsum	50–150		60
Standard low- and high-density rigid wall construction according to EN 1363-1 <ul style="list-style-type: none"> damper remote from the wall 100 mm min. wall thickness 	Ablative Coated Batt	40–200		27
	Insulation of the duct with Rockwool Conlit Ductrock EIS 120 th. 60mm – Stuffing box with fire protective boards	50	EI 120 (v _e) S [V/H]	31
	Insulation of the duct with Rockwool Conlit Ductrock EIS 90 th. 60mm – Stuffing box with fire protective boards	40–75		
	Insulation of the duct with calcium silicate boards Installation frame E6 – Mortar or gypsum	50–150	EI 90 (v _e) S [V/H]	71
	Insulation of the duct with ISOVER ULTIMATE PROTECT th. 120 mm (2x60) – Ablative Coated Batt	40–100		29
Standard flexible wall construction min. EI 90 according to EN 1363-1 <ul style="list-style-type: none"> damper in the wall 100 mm min. wall thickness 	Insulation of the duct with ISOVER ULTIMATE PROTECT th. 80 mm – Ablative Coated Batt	40–75	EI 60 (v _e) S [V/H]	30
	Mortar or gypsum	50–150	EI 120 (v _e) S [V/H] *	32
	2 dampers in battery - Mortar or gypsum	50–150	EI 90 (v _e) S [H]	33
	Stuffing box with fire protective boards	40–75		35
	Installation frame E1, E3	N/A	EI 90 (v _e) S [V/H]	57, 63
Standard flexible wall construction min. EI 60 according to EN 1363-1 <ul style="list-style-type: none"> damper in the wall 100 mm min. wall thickness 	Ablative Coated Batt	40–200		34
	Flexible ceiling - Installation frame E5	N/A		68-69
	Mortar or gypsum	50–150	EI 60 (v _e) S [V/H]	36
	Ablative Coated Batt	40–130		37
	Standard flexible wall construction min. EI 30 according to EN 1363-1 <ul style="list-style-type: none"> damper in the wall 75 mm min. wall thickness 	Mortar or gypsum	50–150	EI 30 (v _e) S [V/H]
Ablative Coated Batt		40–155	EI 45 (v _e) S [V/H]	39
Standard flexible wall construction min. EI 90 according to EN 1363-1 <ul style="list-style-type: none"> damper remote from the wall 100 mm min. wall thickness 		Insulation of the duct with Rockwool Conlit Ductrock EIS 120 th. 60mm – Stuffing box with fire protective boards	50	EI 120 (v _e) S [V/H]
	Insulation of the duct with Rockwool Conlit Ductrock EIS 90 th. 60mm – Stuffing box with fire protective boards	40–75	EI 90 (v _e) S [V/H]	
	Insulation of the duct with ISOVER ULTIMATE PROTECT th. 120 mm (2x60) – Ablative Coated Batt	40–100		40
	Insulation of the duct with ISOVER ULTIMATE PROTECT th. 80 mm – Ablative Coated Batt	40–75	EI 60 (v _e) S [V/H]	41
Non-standard CLT wooden wall construction min. REI 60 <ul style="list-style-type: none"> damper in the wall 100 mm min. wall thickness 	Mortar or gypsum	50–150	EI 90 (v _e) S [V/H]	43
	Ablative Coated Batt	40–200		44
Non-standard lightweight wall construction ROCKWOLL Cavity Barrier EN <ul style="list-style-type: none"> damper in the wall 100 mm min. wall thickness 	Detailed description of installation method → see page 45	N/A	EI 60 (v _e) S [V/H]	45
Non-standard asymm. shaft wall construction, min. EI 60, made of gypsum plasterboards (2x12,5 mm and 1x19 mm) with steel studs <ul style="list-style-type: none"> damper in the wall 85 mm min. wall thickness 	Mortar or gypsum	50–150	EI 60 (v _e) S [V/H]	46
		50	EI 90 (v _e) S [V/H]	
	Ablative Coated Batt	40–130	EI 60 (v _e) S [V/H]	47
		100	EI 90 (v _e) S [V/H]	
Standard low- and high-density rigid floor construction according to EN 1366-2 <ul style="list-style-type: none"> damper in the ceiling 150 mm min. ceiling thickness 	Mortar or gypsum	50–150	EI 90 (h _o) S [H] *	48
		50	EI 120 (h _o) S [H] *	
	Installation frame E1, E4	N/A		58, 66
	Installation frame E2 - Mortar or gypsum	50–150	EI 90 (h _o) S [H]	61
Standard low- and high-density rigid floor construction according to EN 1366-2 <ul style="list-style-type: none"> damper remote from the ceiling 150 mm min. ceiling thickness 	Ablative Coated Batt	40–200		49
	Insulation of the duct with Rockwool Conlit Ductrock EIS 90 th. 60 mm – Mortar or gypsum	50–150		50
	Concreting	50–150	EI 90 (h _o) S [H]	51
	Insulation of the duct with calcium silicate boards Installation frame E6 – Mortar or gypsum	50–150		72
Non-standard CLT wooden ceiling construction min. REI 60 <ul style="list-style-type: none"> damper in the ceiling 140 mm min. ceiling thickness 	Mortar or gypsum	50–150	EI 90 (h _o) S [H]	52
	Ablative Coated Batt	40–200		53

* Tested at increased underpressure of 500 Pa.

In solid wall construction

In solid wall construction - mortar or gypsum

EI 120 (v_e) S [V/H] - 500 Pa

- Standard low- and high-density rigid wall construction according to EN 1363-1
- Damper can be installed at a minimum distance of 40 mm from surrounding constructions.
- For connection of following duct → see page 77

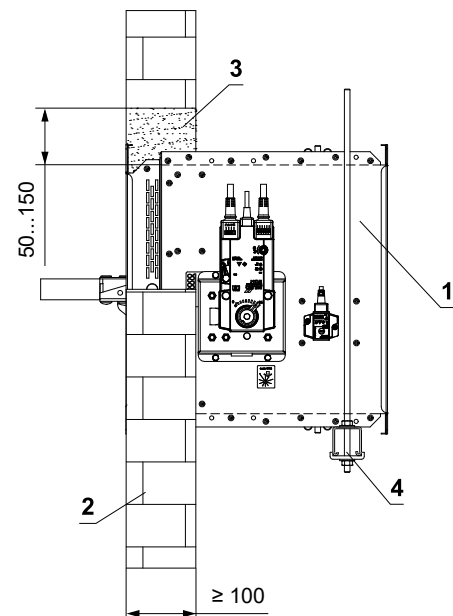
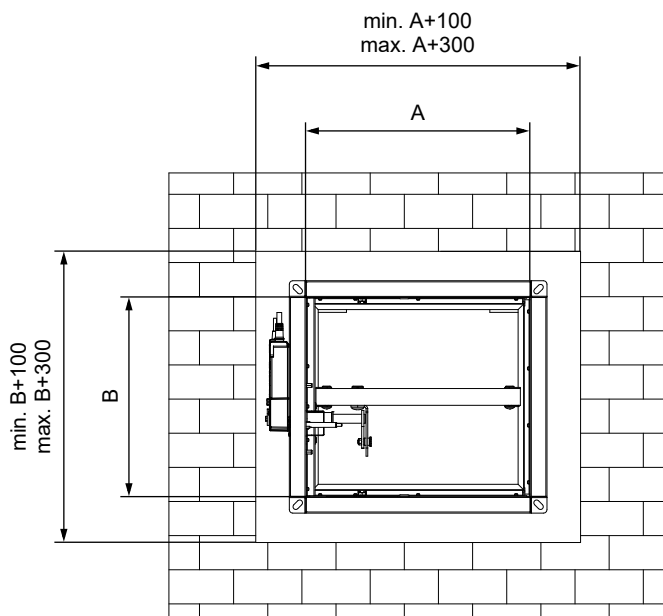
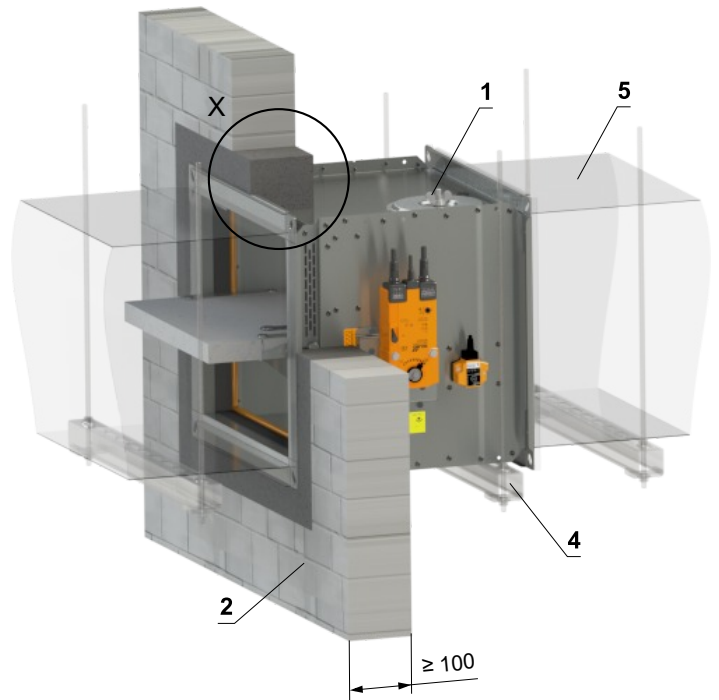
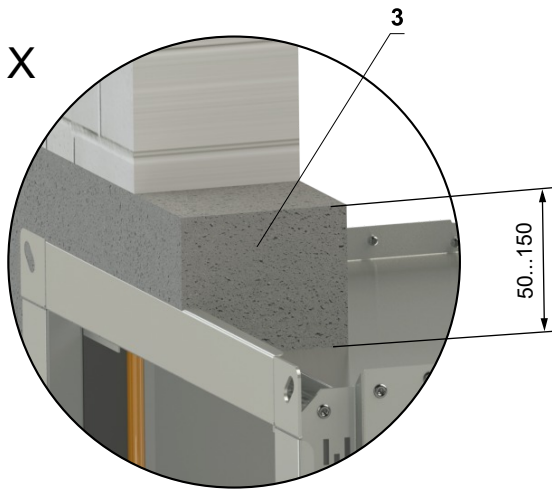

- 1 FDMB
- 2 Solid wall construction
- 3 Mortar or gypsum
- 4 Profile with threaded rod → see pages 73 to 76
- 5 Duct

In solid wall construction - Ablative Coated Batt

EI 90 (ve) S [V/H]

- Standard low- and high-density rigid wall construction according to EN 1363-1
- Damper can be installed at a minimum distance of 40 mm from surrounding constructions.
- For connection of following duct → see page 77

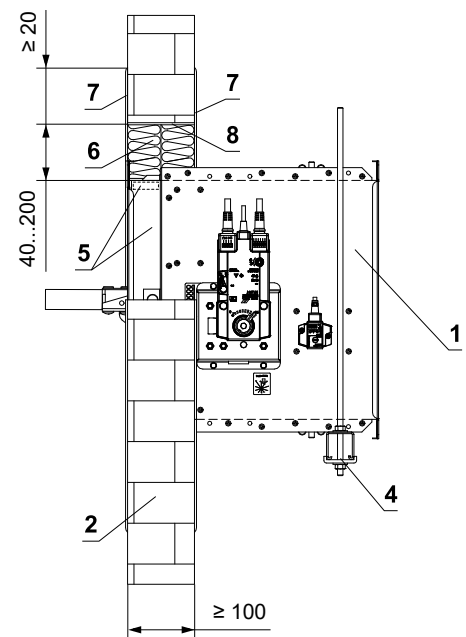
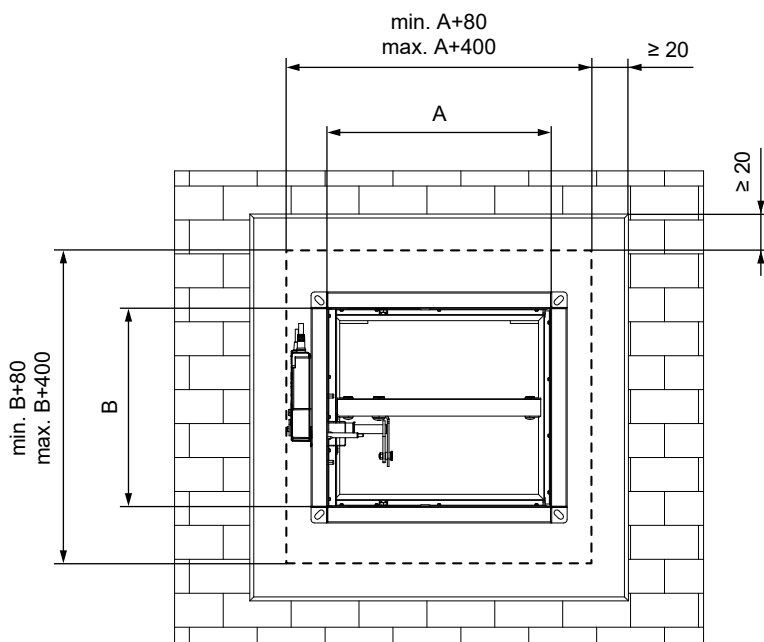
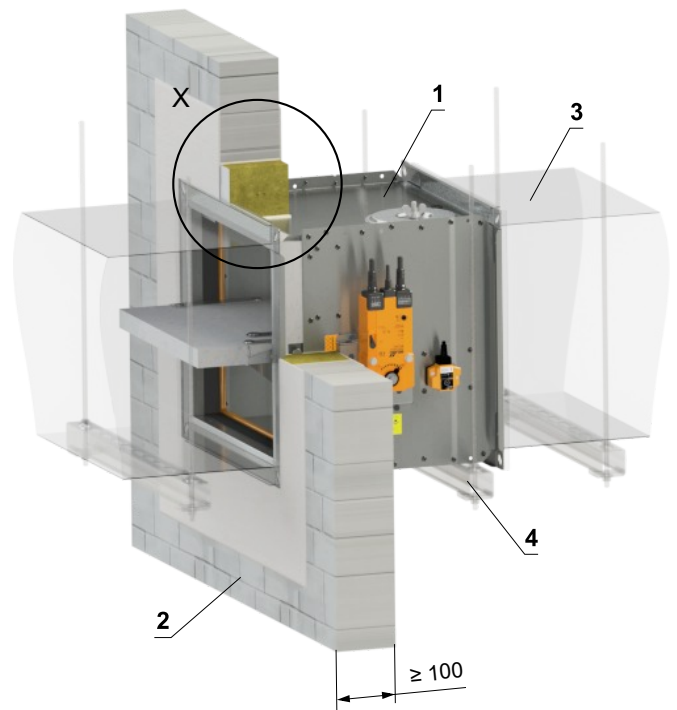
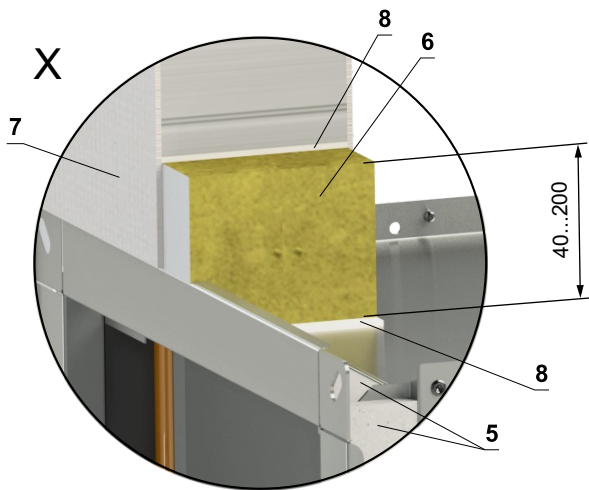

- 1 FDMB
- 2 Solid wall construction
- 3 Duct
- 4 Profile with threaded rod → see pages 73 to 76
- 5 Protective cladding board - min. th. 10 mm, min. density 870 kg/m³ (e.g. PROMATECT-H) → see page 87
Ablative Coated Batt System HILTI*
- 6 Mineral wool board - min. density 140 kg/m³ (HILTI CFS-CT B 1S 140/50...)
- 7 Fire stop coating - th. 1 mm (HILTI CFS-CT...) - coating is overcoated on the support construction and on the damper casing/duct
- 8 Fire-resistant mastic - (HILTI CFS-S ACR...) fill the gap from both sides of the fire separation construction and around the perimeter of penetration and damper casing

* HILTI system can be replaced by a similar system with the same or higher thickness, density, fire reaction class, tested according to EN 1366-3.

In solid wall construction - mineral wool with fire-resistant coating and fire-resistance boards

EI 90 (ve) S [V/H]

- Standard low- and high-density rigid wall construction according to EN 1363-1
- For connection of following duct → see page 77

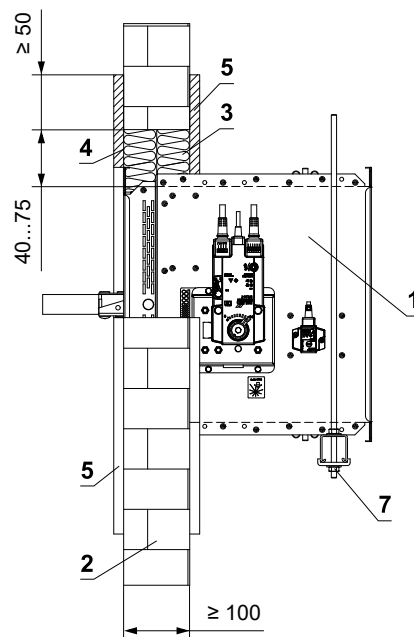
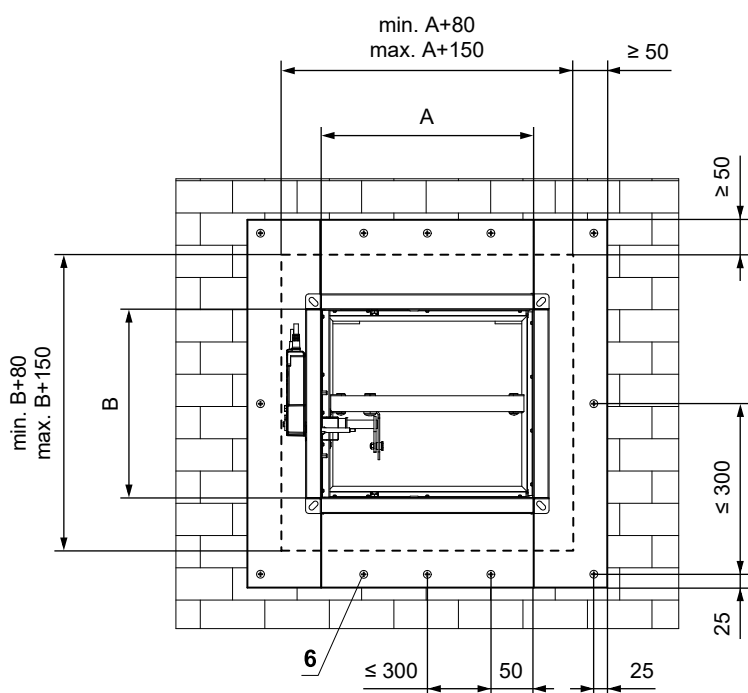
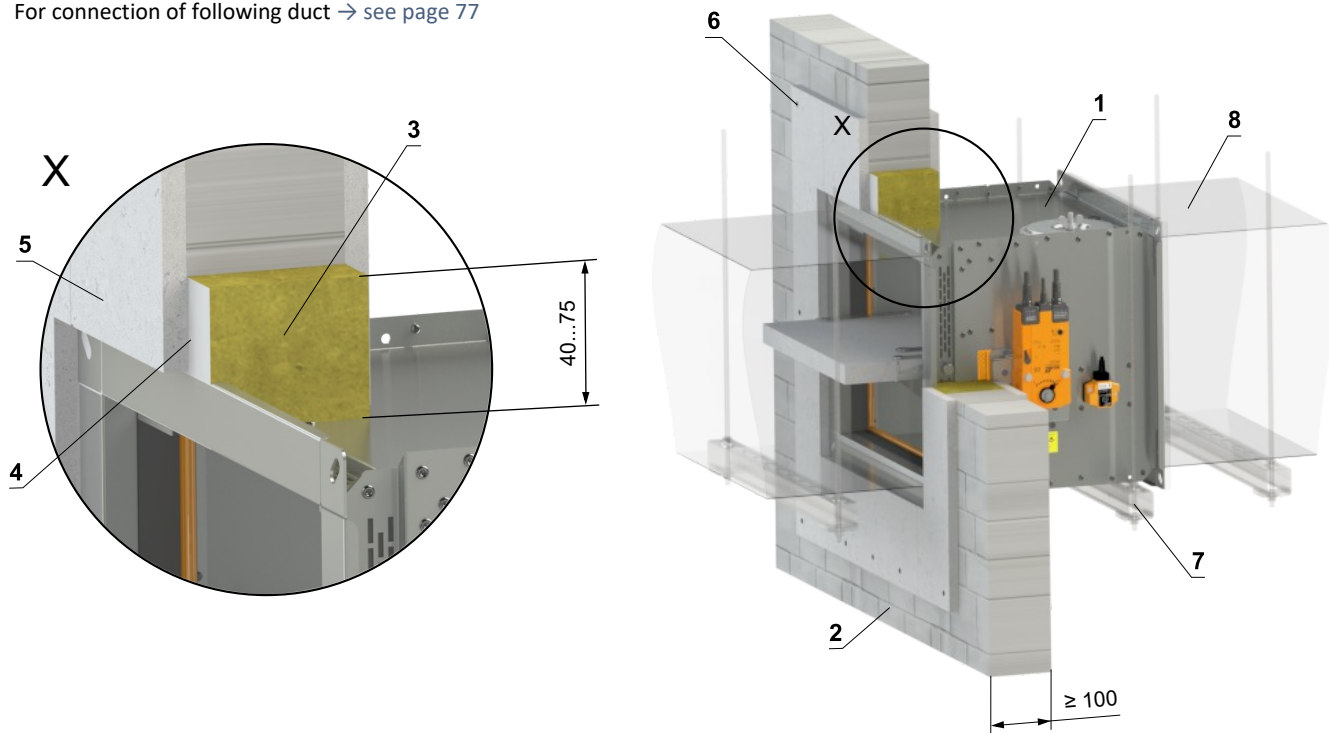

- 1 FDMB
- 2 Solid wall construction
- 3 Mineral wool board - min. density 140 kg/m³ (e.g. PROMAPYR-T150, ROCKWOOL HARDROCK / STEPROCK HD)
- 4 Fire-resistant coating - th. 1 mm (e.g. PROMASTOP-I)
- 5 Fire-resistant board - min. th. 15 mm, min. density 870 kg/m³ (e.g. PROMATECT-H)
- 6 Screw 4x50 mm - screws must be fixed in the wall construction, use steel anchors if necessary
- 7 Profile with threaded rod → see pages 73 to 76
- 8 Duct

Installation outside solid wall construction

Outside solid wall construction - ISOVER Ultimate Protect - Ablative Coated Batt

EI 90 (v_e) S [V/H]

- Standard low- and high-density rigid wall construction according to EN 1363-1
- For connection of following duct → see page 77
- Minimum and maximum distance between the wall and fire damper is unlimited
- When installing the insulation, follow the ISOVER manufacturer's instructions
- The damper and the duct must be suspended separately
- The duct must be suspended on both sides of damper acc. to national rules
- Duct between fire damper and fire separating construction must be suspended by using threaded rods and mounting profiles, or another mounting system acc. to national standards
- Load of the suspension system depends on weight of the fire damper and duct system → see page 73
- Max. distance between two suspension systems is 1500 mm
- Duct at the point of penetration must be fixed to the fire separation structure
- Following air-conditioning duct must be suspended or supported so that all load transfer from the following duct to the fire damper is absolutely excluded. Adjacent duct must be suspended or supported, as required by the duct suppliers
- Damper inspection holes are covered with insulation, therefore it's necessary to make an inspection hole on the connecting duct
- If the threaded rod is located inside the duct insulation, distance between threaded rod and duct is max 30 mm
- If the threaded rod is located outside the duct isolation, distance between threaded rod and isolation is max. 40 mm
- For this installation VRM2-B reinforcement frame must be used → see page 86

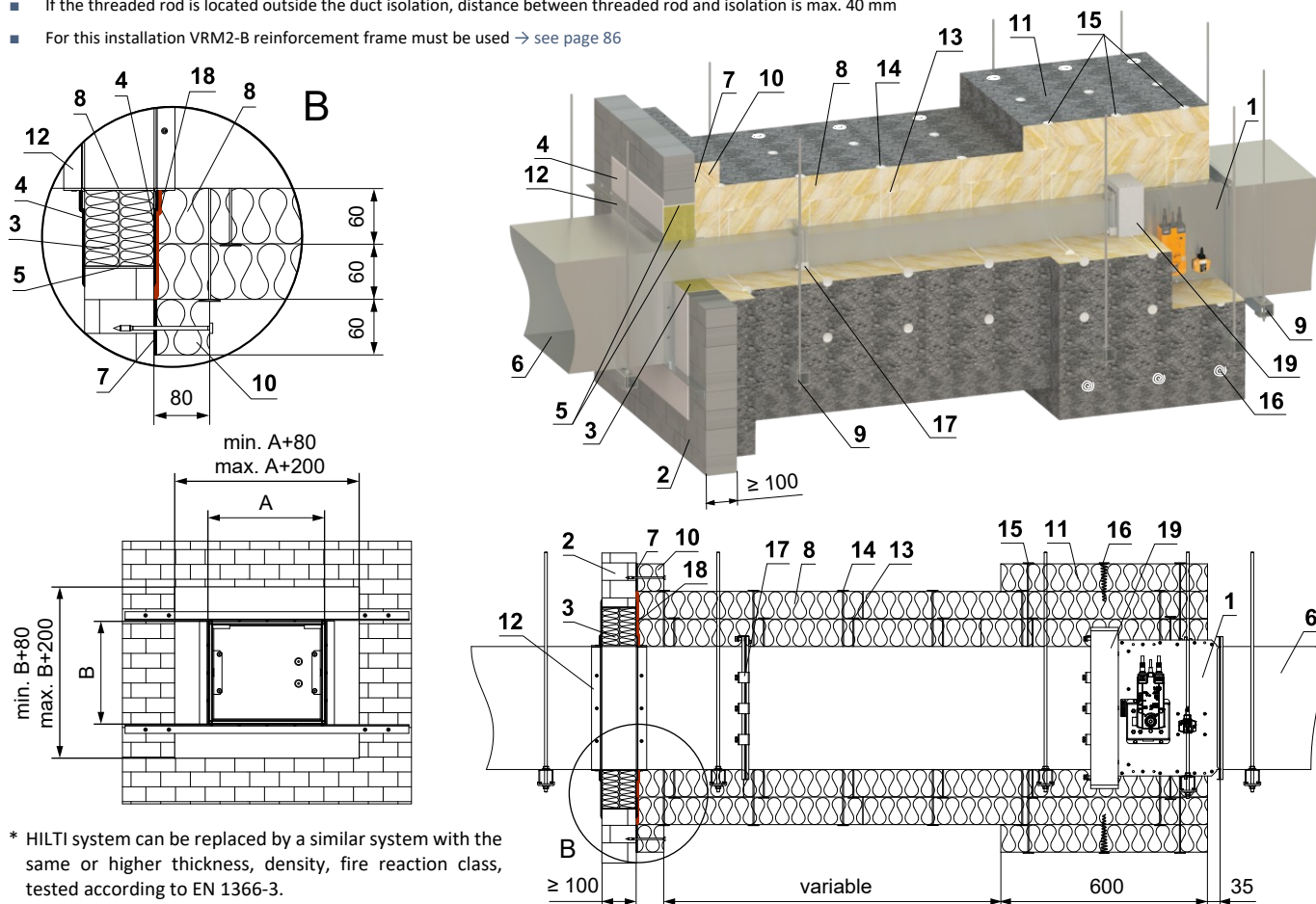

* HILTI system can be replaced by a similar system with the same or higher thickness, density, fire reaction class, tested according to EN 1366-3.

- | | |
|---|---|
| <ol style="list-style-type: none"> 1 FDMB 2 Solid wall construction
Ablative Coated Batt System HILTI* 3 Mineral wool board - min. density 140 kg/m³ (HILTI CFS-CT B 1S 140/50...) 4 Fire stop coating - th. 1 mm (HILTI CFS-CT...) - coating is overcoated on the support construction and on the damper casing/duct 5 Fire-resistant mastic - (HILTI CFS-S ACR...) fill the gap from both sides of the fire separation construction and around the perimeter of penetration and damper casing 6 Standard air duct, made of galvanized sheet metal, thickness according to damper size 7 ISOVER Protect BSK glue - apply on the insulation and fix it to the fire separation construction 8 Insulation board made of mineral wool, with a surface treatment of aluminum foil, thickness 60 mm, min. density 66 kg/m³ (System ISOVER Ultimate Protect Wired Mat 4.0 Alu1) | <ol style="list-style-type: none"> 9 Profile with threaded rod → see pages 73 to 76 10 Duct penetration insulation collar - th. 60 mm - ISOVER Ultimate Protect SLAB 4.0 Alu1, - glued (pos. 7) and fixed with screws to the wall construction 11 Insulating collar of the damper and duct connection - th. 60 mm ISOVER Ultimate Protect SLAB 4.0 Alu1 12 L-profile 30x30x3 mm - installation acc. to ISOVER 13 Stud-welded pin 60 mm - quantity and placing acc. to ISOVER 14 Stud-welded pin 120 mm - quantity and placing acc. to ISOVER 15 Stud-welded pin 180 mm - quantity and placing acc. to ISOVER 16 Fire spiral shaped screw - quantity and placing acc. to ISOVER 17 Steel clamp min. bolt M8 18 ISOVER Protect BSF 19 VRM2-B → see page 86 |
|---|---|

Outside solid wall construction - ISOVER Ultimate Protect - Ablative Coated Batt

EI 60 (ve) S [V/H]

- Standard low- and high-density rigid wall construction according to EN 1363-1
- For connection of following duct → see page 77
- Minimum and maximum distance between the wall and fire damper is unlimited
- When installing the insulation, follow the ISOVER manufacturer's instructions
- The damper and the duct must be suspended separately
- The duct must be suspended on both sides of damper acc. to national rules
- Duct between fire damper and fire separating construction must be suspended by using threaded rods and mounting profiles, or another mounting system acc. to national standards
- Load of the suspension system depends on weight of the fire damper and duct system → see page 73
- Max. distance between two suspension systems is 1500 mm
- Duct at the point of penetration must be fixed to the fire separation structure
- Following air-conditioning duct must be suspended or supported so that all load transfer from the following duct to the fire damper is absolutely excluded. Adjacent duct must be suspended or supported, as required by the duct suppliers
- If the threaded rod is located inside the duct insulation, distance between threaded rod and duct is max 30 mm
- If the threaded rod is located outside the duct isolation, distance between threaded rod and isolation is max. 40 mm

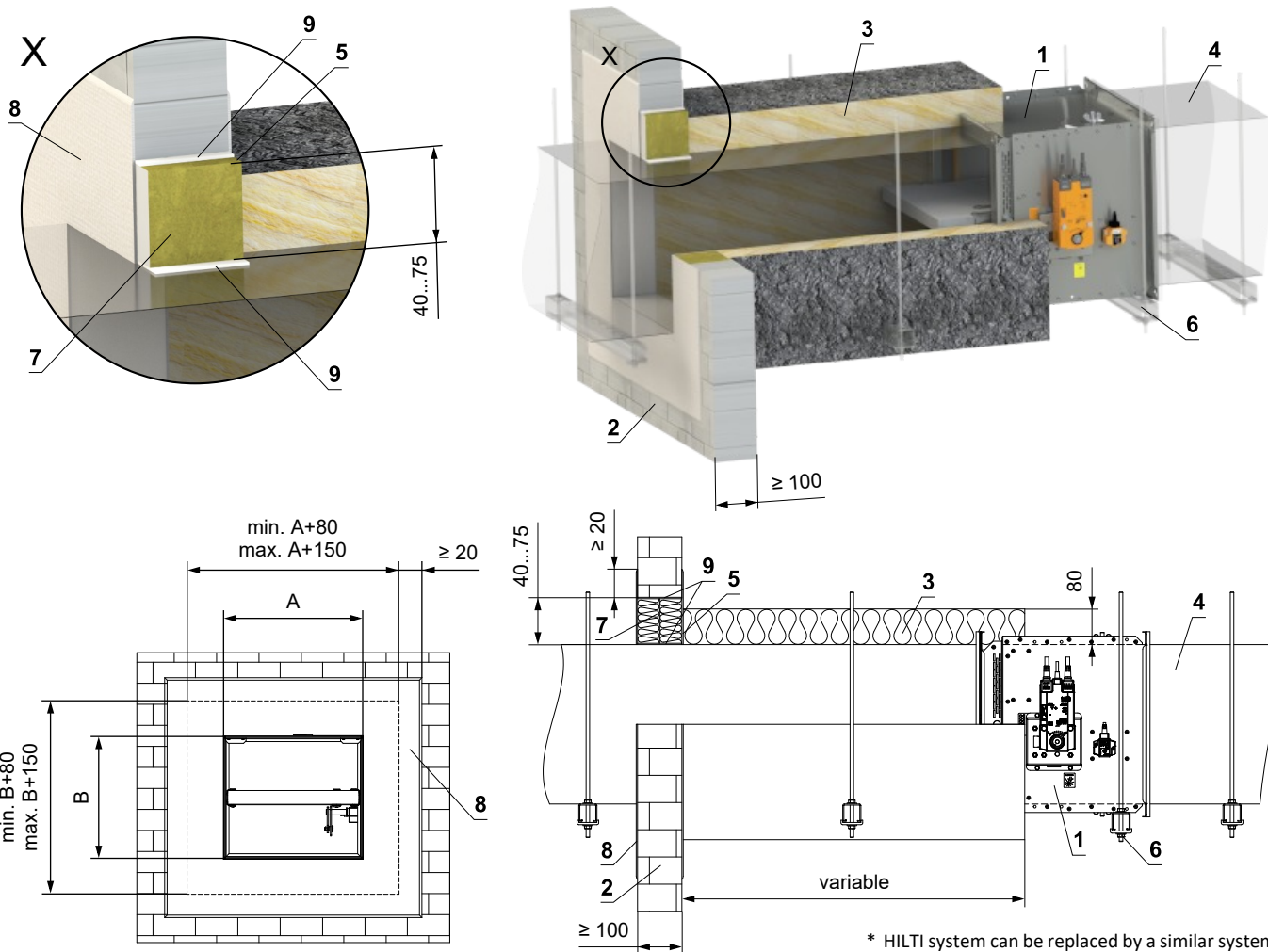

- 1 FDMB
- 2 Solid wall construction
- 3 Insulation board made of mineral wool, with a surface treatment of aluminum foil, min. thickness 80 mm, min. density 66 kg/m³ (System ISOVER Ultimate Protect Wired Mat 4.0 Alu1)
- 4 Standard air duct, made of galvanized sheet metal, thickness according to damper size
- 5 ISOVER Protect BSK glue - apply on the insulation and fix it to the fire separation construction
- 6 Profile with threaded rod → see pages 73 to 76
Ablative Coated Batt System HILTI*
- 7 Mineral wool board - min. density 140 kg/m³ (HILTI CFS-CT B 1S 140/50...)
- 8 Fire stop coating - th. 1 mm (HILTI CFS-CT...) - coating is overcoated on the support construction and on the damper casing/duct
- 9 Fire-resistant mastic - (HILTI CFS-S ACR...) fill the gap from both sides of the fire separation construction and around the perimeter of penetration and damper casing

* HILTI system can be replaced by a similar system with the same or higher thickness, density, fire reaction class, tested according to EN 1366-3.

Outside solid wall construction - mineral wool ROCKWOOL - mineral wool with fire-resistant coating and fire-resistant board

EI 90 (v_e) S [V/H]
***EI 120 (v_e) S [V/H]**

- Standard low- and high-density rigid wall construction according to EN 1363-1
- For connection of following duct → see page 77
- Minimum and maximum distance between the wall and fire damper is unlimited
- When installing the insulation, follow the ROCKWOOL manufacturer's instructions
- The damper and the duct must be suspended separately
- The duct must be suspended on both sides of damper acc. to national rules
- Duct between fire damper and fire separating construction must be suspended by using threaded rods and mounting profiles, or another mounting system acc. to national standards
- Load of the suspension system depends on weight of the fire damper and duct system → see page 73
- Max. distance between two suspension systems is 1500 mm
- Duct at the point of penetration must be fixed to the fire separation structure
- Following air-conditioning duct must be suspended or supported so that all load transfer from the following duct to the fire damper is absolutely excluded. Adjacent duct must be suspended or supported, as required by the duct suppliers
- If the threaded rod is located inside the duct insulation, distance between threaded rod and duct is max 30 mm
- If the threaded rod is located outside the duct isolation, distance between threaded rod and isolation is max. 40 mm
- For this installation VRM-B reinforcement frame must be used → see page 85

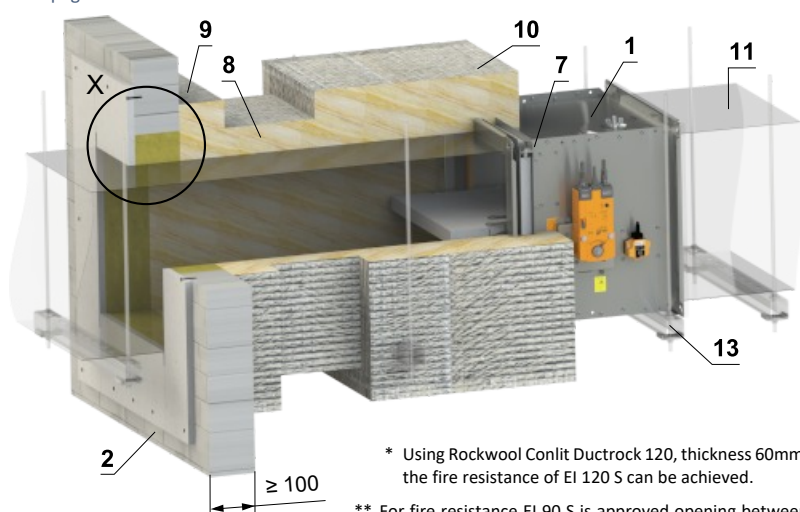
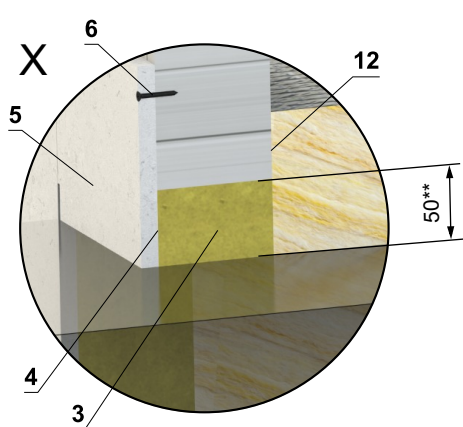

* Using Rockwool Conlit Ductrock 120, thickness 60mm, the fire resistance of EI 120 S can be achieved.

** For fire resistance EI 90 S is approved opening between the construction and the duct in the range of 40...75 mm.

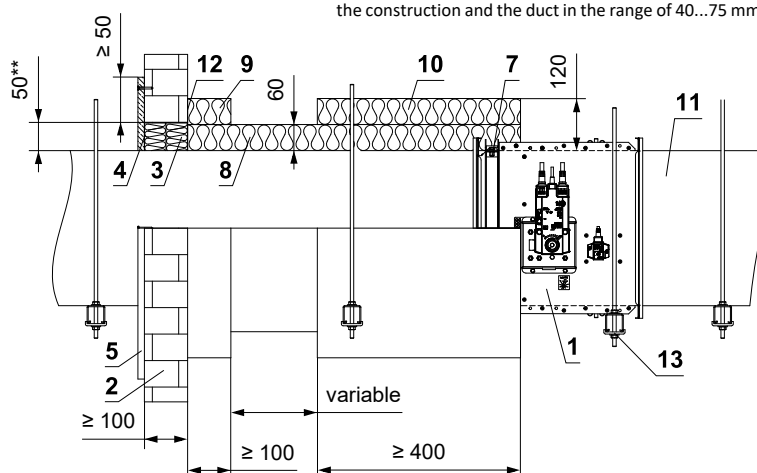
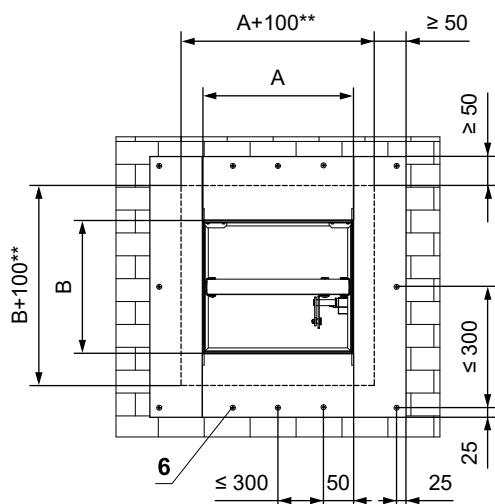

- 1 FDMB
- 2 Solid wall construction
- 3 Mineral wool board - min. density 140 kg/m³ (e.g. PROMAPYR-T150, ROCKWOOL HARDROCK / STEPROCK HD)
- 4 Fire-resistant coating - th. 1 mm (e.g. PROMASTOP-I)
- 5 Fire-resistant board - min. th. 15 mm, min. density 870 kg/m³ (e.g. PROMATECT-H)
- 6 Screw 4x50 mm - screws must be fixed in the wall construction, use steel anchors if necessary
- 7 VRM-B → see page 85

- 8 Insulation board made of mineral wool, with a surface treatment of aluminum foil - th. 60 mm, min. density 300 kg/m³ - (System ROCKWOOL Conlit Ductrock 90(120*))
- 9 Duct penetration insulation collar - th. 60 mm (System ROCKWOOL Conlit Ductrock 90(120*)) - glued (pos. 12) and fixed with screws to the wall construction
- 10 Insulation collar of the damper and duct connection - th. 60 mm (System ROCKWOOL Conlit Ductrock 90(120*))
- 11 Standard air duct, made of galvanized sheet metal, thickness according to damper size
- 12 ROCKWOOL Firepro glue - apply on the insulation and fix it to the fire separation construction
- 13 Profile with threaded rod → see pages 73 to 76

In gypsum wall construction

In gypsum wall construction min. EI 90 - mortar or gypsum

EI 120 (v_e) S [V/H] - 500 Pa

- Standard flexible wall construction min. EI 90 according to EN 1363-1.
- Damper can be installed at a minimum distance of 40 mm from surrounding constructions.
- For connection of following duct → see page 77
- The installation opening is lined with a UW/CW profile.

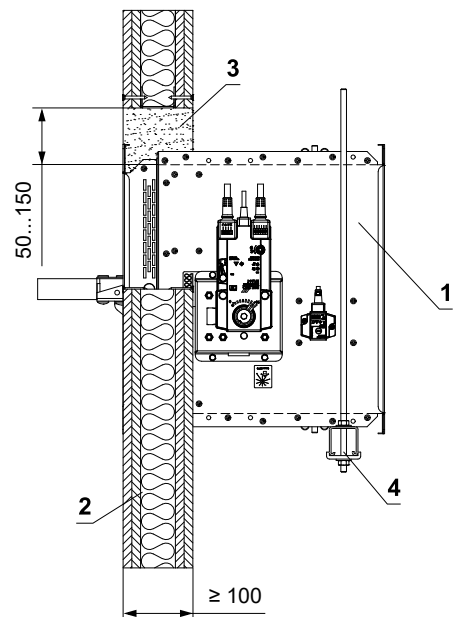
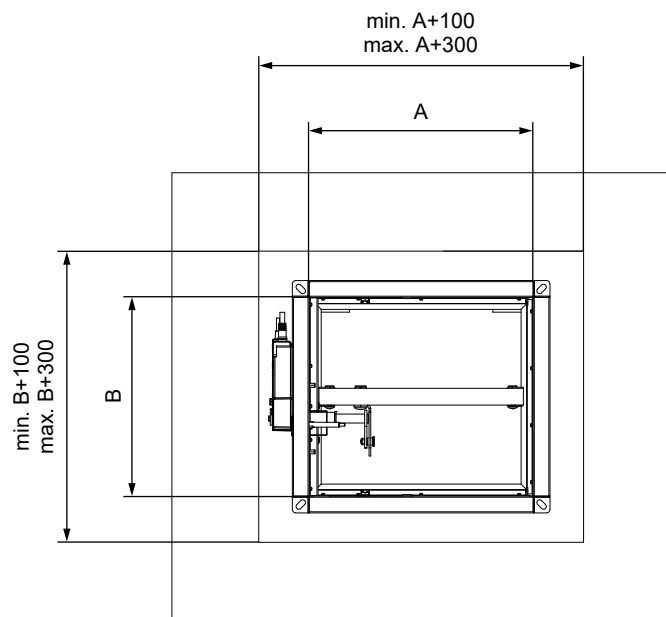
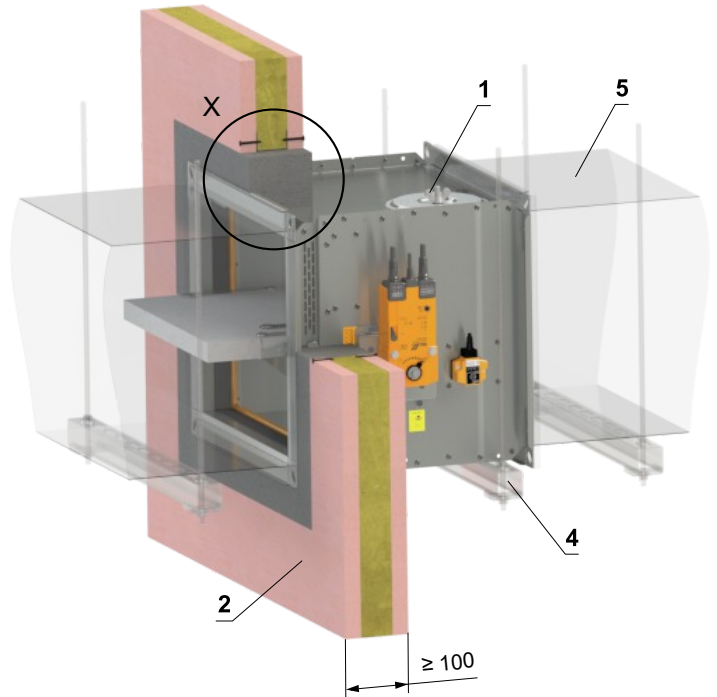
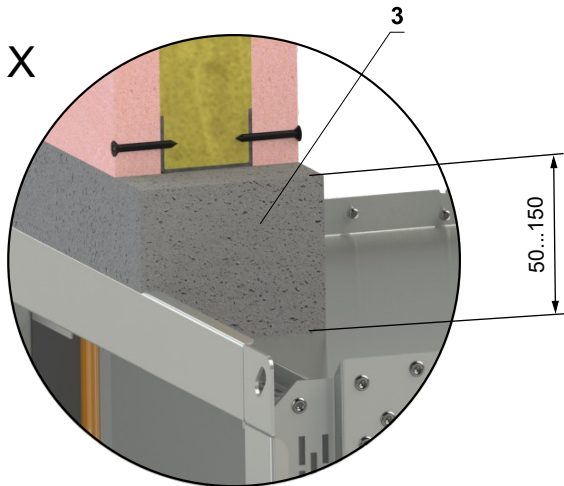

- 1 FDMB
- 2 Gypsum wall construction
- 3 Mortar or gypsum
- 4 Profile with threaded rod → see pages 73 to 76
- 5 Duct

In gypsum wall construction min. EI 90 - 2 dampers in battery - mortar or gypsum

EI 90 (v_e) S [H]

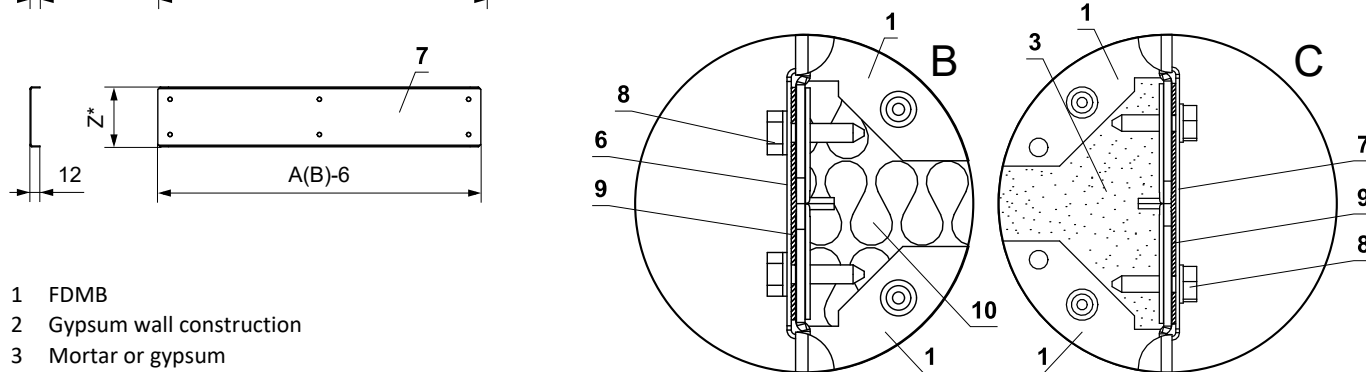
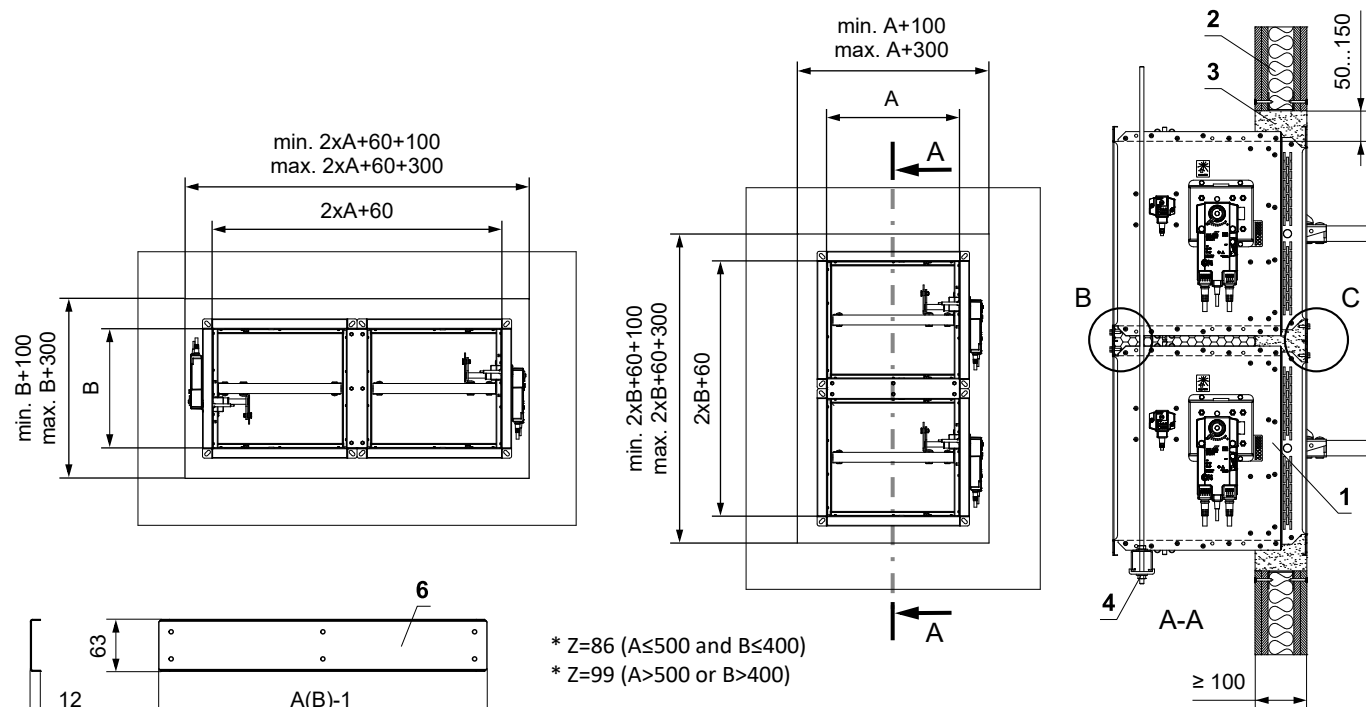
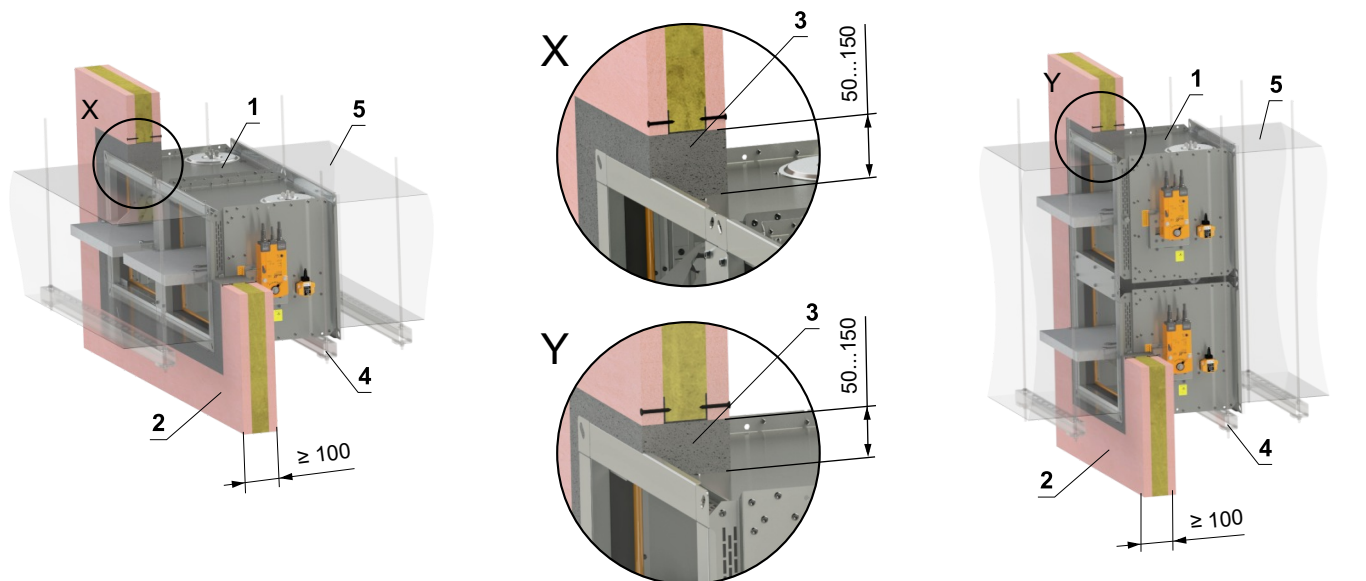

- 1 FDMB
- 2 Gypsum wall construction
- 3 Mortar or gypsum
- 4 Profile with threaded rod → see pages 73 to 76
- 5 Duct
- 6 U-profile type 3
- 7 U-profile type 1
- 8 Screw TEX 4,8x18 mm (pitch ≤ 200 mm)
- 9 Sealing
- 10 Insulation board made of mineral wool - recommended for easy filling of gap with mortar/gypsum.

- Standard flexible wall construction min. EI 90 according to EN 1363-1.
- For connection of following duct → see page 77
- The gap between the damper and construction is filled with mortar or gypsum
- The installation opening is lined with a UW/CW profile.

In gypsum wall construction min. EI 90 - Ablative Coated Batt - 100 mm

EI 90 (v_e) S [V/H]

- Standard flexible wall construction min. EI 90 according to EN 1363-1.
- Damper can be installed at a minimum distance of 40 mm from surrounding constructions.
- For connection of following duct → see page 77
- The installation opening is lined with a UW/CW profile.

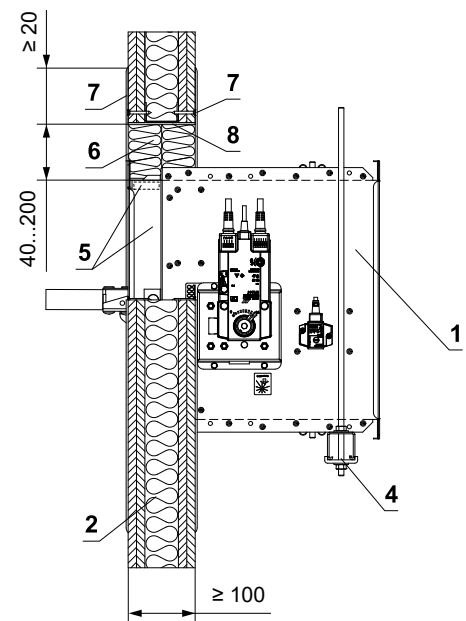
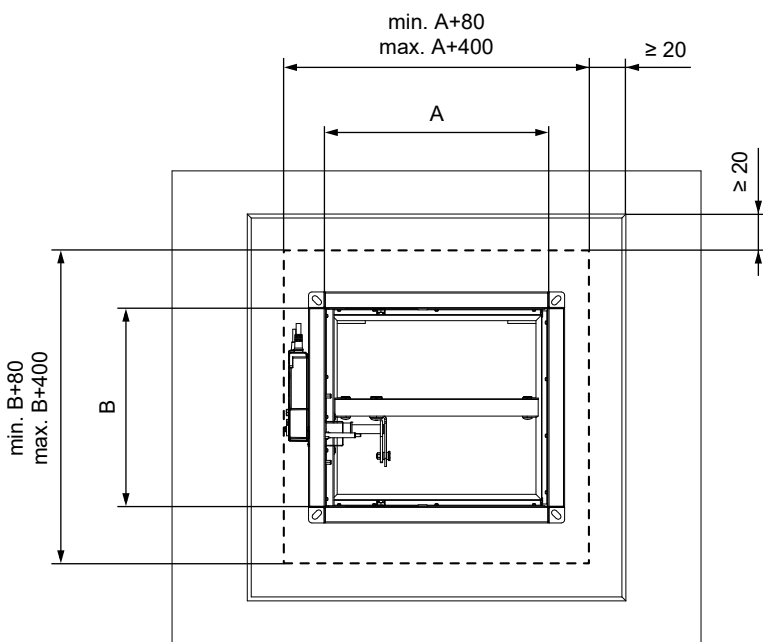
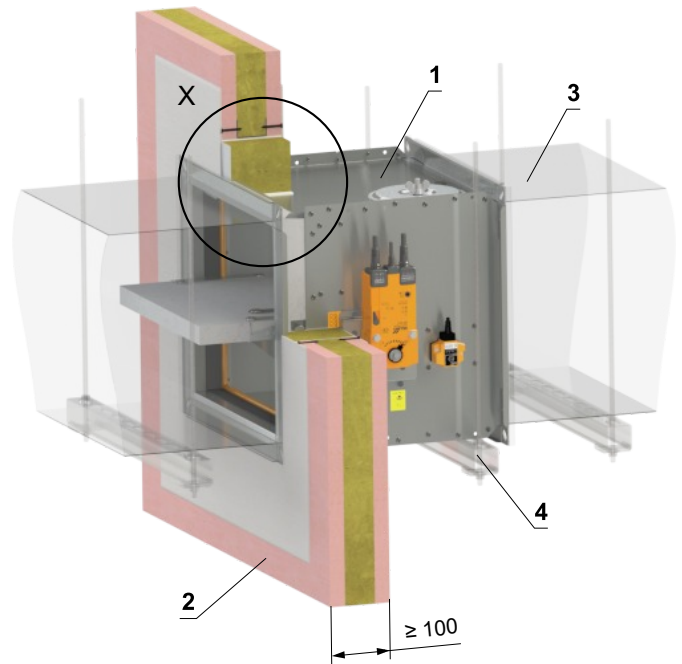
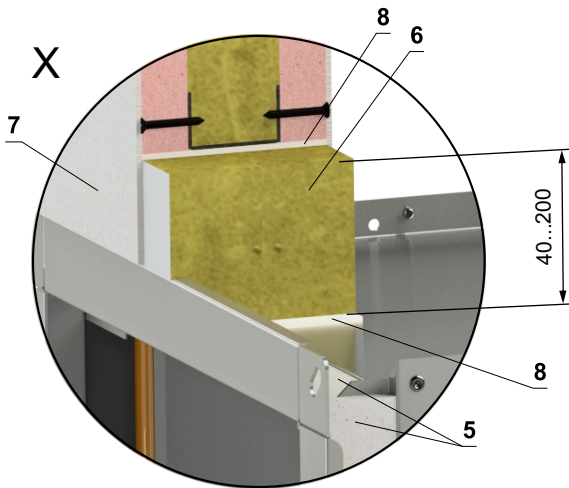

- 1 FDMB
- 2 Gypsum wall construction
- 3 Duct
- 4 Profile with threaded rod → see pages 73 to 76
- 5 Protective cladding board - min. 10 mm, min. density 870 kg/m³ (e.g. PROMATECT-H) → see page 87
Ablative Coated Batt System HILTI*
- 6 Mineral wool board - min. density 140 kg/m³ (HILTI CFS-CT B 1S 140/50...)
- 7 Fire stop coating - th. 1 mm (HILTI CFS-CT...) - coating is overcoated on the support construction and on the damper casing/duct
- 8 Fire-resistant mastic - (HILTI CFS-S ACR...) fill the gap from both sides of the fire separation construction and around the perimeter of penetration and damper casing

* HILTI system can be replaced by a similar system with the same or higher thickness, density, fire reaction class, tested according to EN 1366-3.

In gypsum wall construction min. EI 90 - mineral wool with fire-resistant coating and fire-resistance boards EI 90 (v_e) S [V/H]

- Standard flexible wall construction min. EI 90 according to EN 1363-1.
- For connection of following duct → see page 77
- The installation opening is lined with a UW/CW profile.

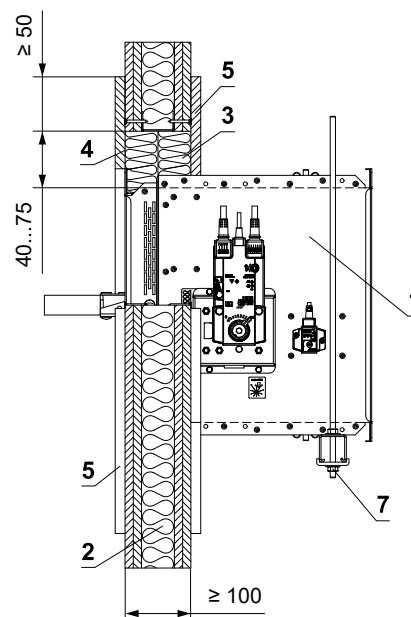
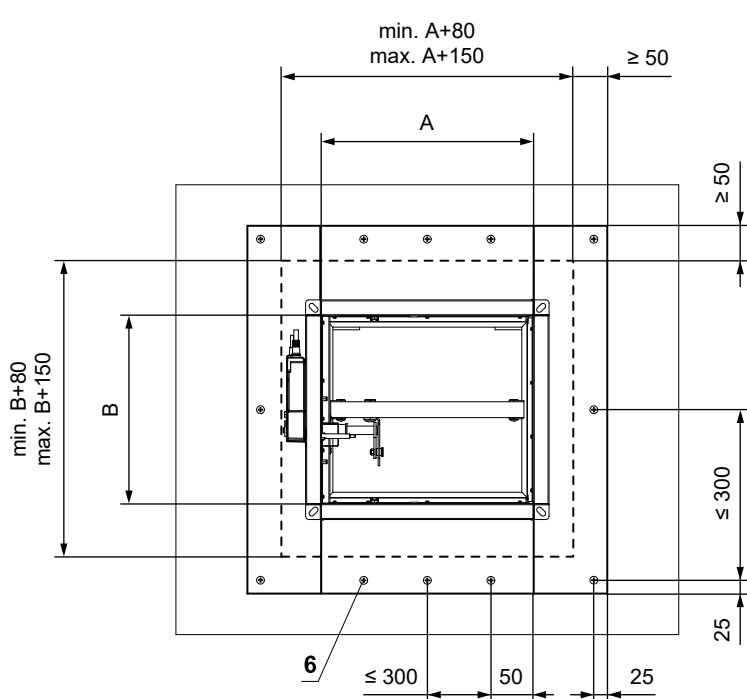
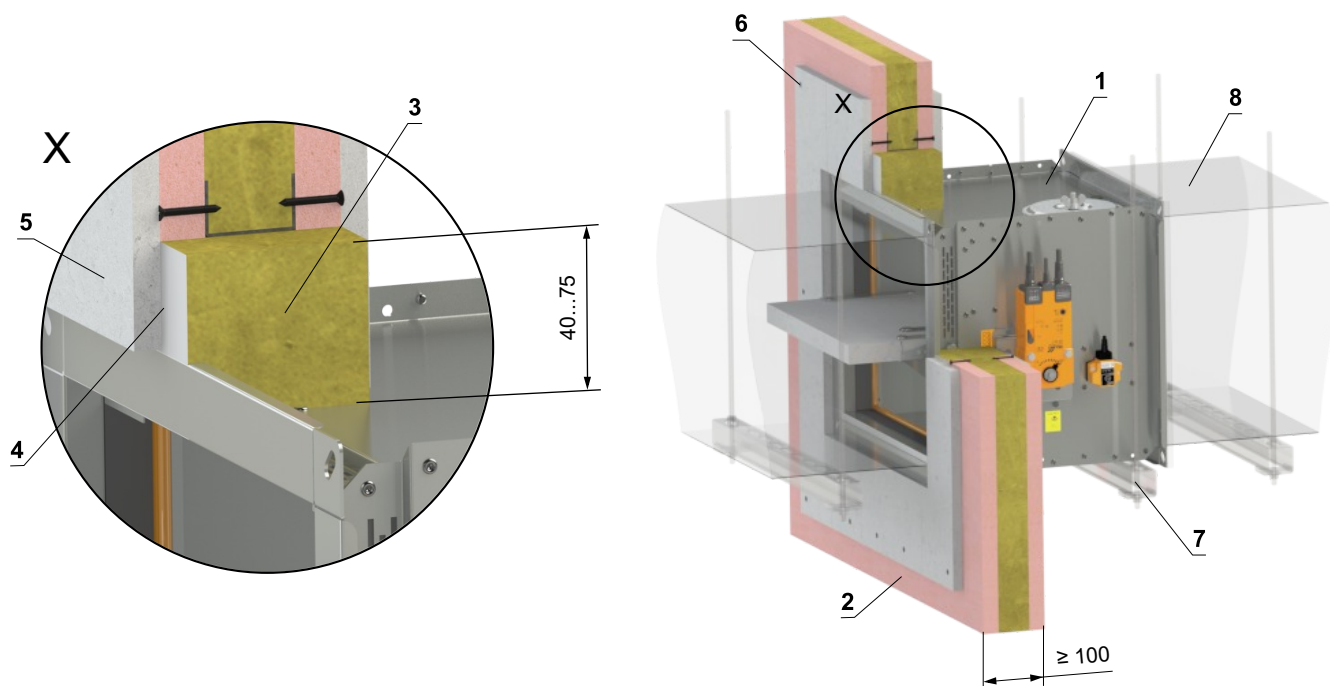

- 1 FDMB
- 2 Gypsum wall construction
- 3 Mineral wool board - min. density 140 kg/m³ (e.g. PROMAPYR-T150, ROCKWOOL HARDROCK / STEPROCK HD)
- 4 Fire-resistant coating - th. 1 mm (e.g. PROMASTOP-I)
- 5 Fire-resistant board - min. th. 15 mm, min. density 870 kg/m³ (e.g. PROMATECT-H)
- 6 Screw 4x50 mm - screws must be fixed in the wall construction, use steel anchors if necessary
- 7 Profile with threaded rod → see pages 73 to 76
- 8 Duct

In gypsum wall construction min. EI 60 - mortar or gypsum

EI 60 (v_e) S [V/H]

- Standard flexible wall construction min. EI 60 according to EN 1363-1.
- For connection of following duct → see page 77
- The installation opening is lined with a UW/CW profile.

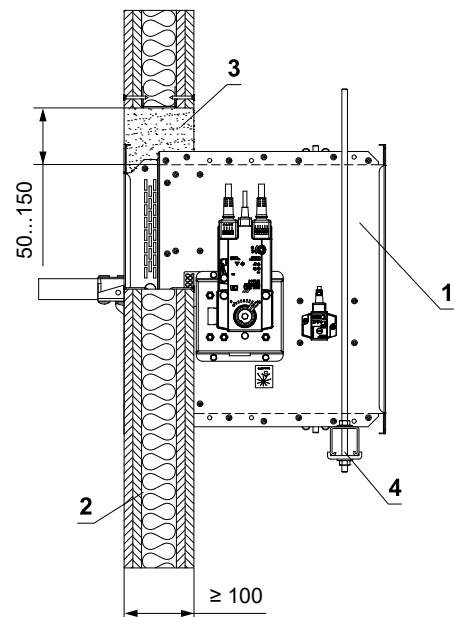
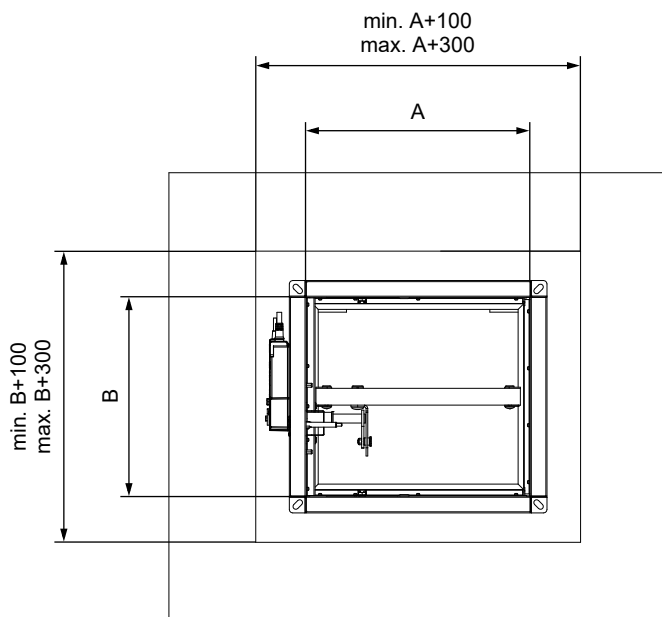
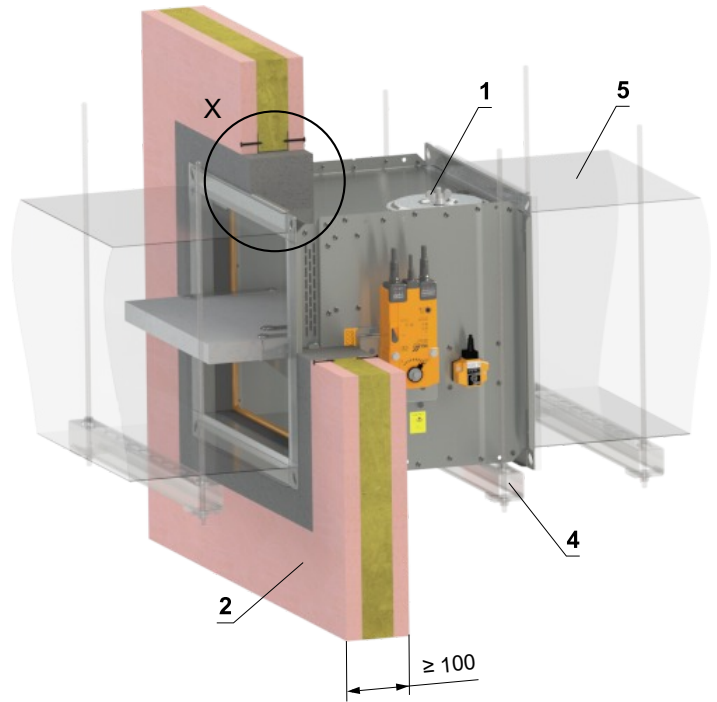
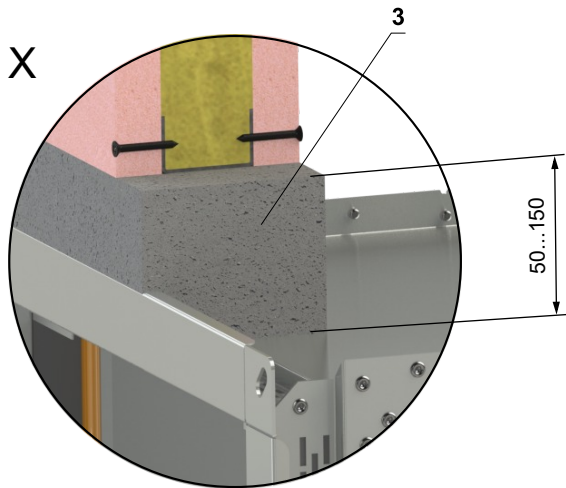

- 1 FDMB
- 2 Gypsum wall construction
- 3 Mortar or gypsum
- 4 Profile with threaded rod → see pages 73 to 76
- 5 Duct

In gypsum wall construction min. EI 60 - Ablative Coated Batt - 100 mm

EI 60 (ve) S [V/H]

- Standard flexible wall construction min. EI 60 according to EN 1363-1.
- For connection of following duct → see page 77
- The installation opening is lined with a UW/CW profile.

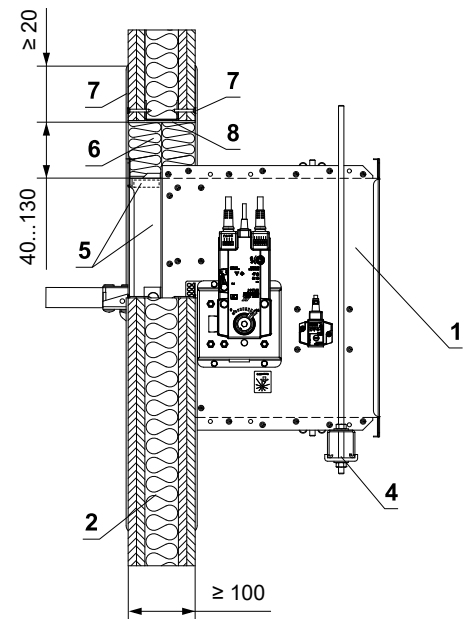
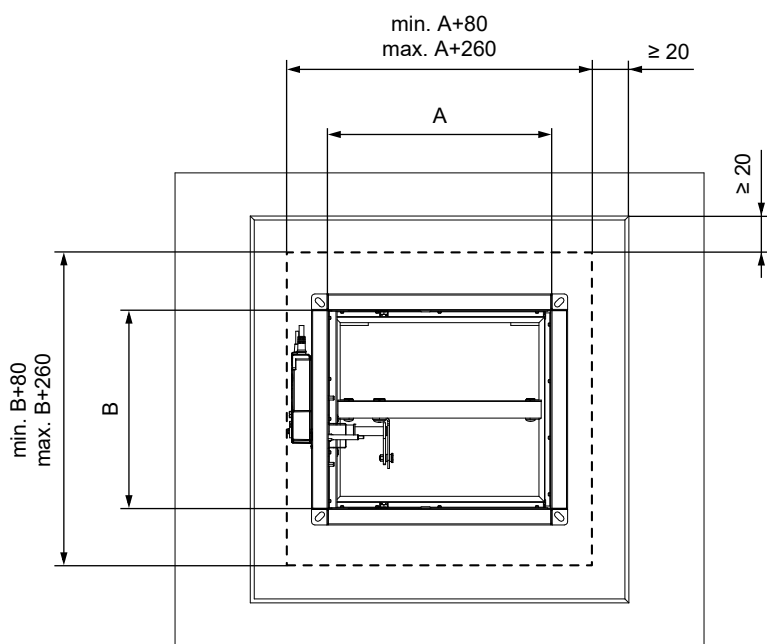
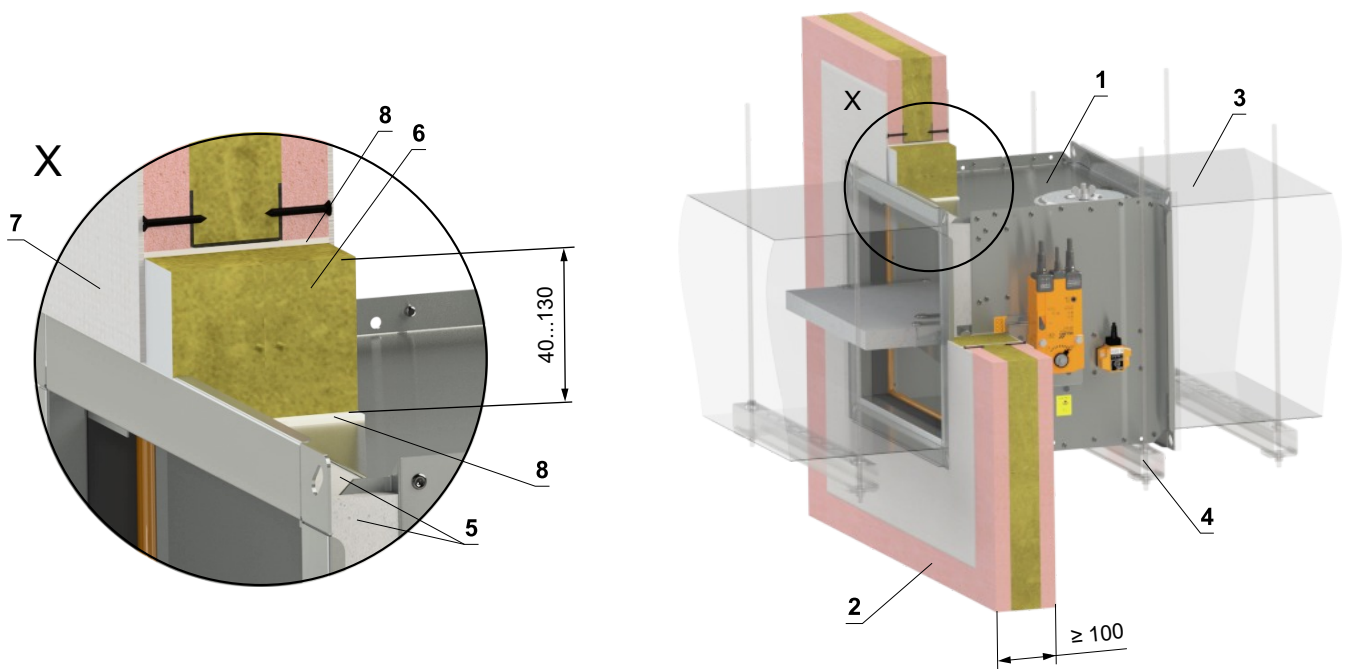

- 1 FDMB
- 2 Gypsum wall construction
- 3 Duct
- 4 Profile with threaded rod → see pages 73 to 76
- 5 Protective cladding board - min. th. 10 mm, min. density 870 kg/m³ (e.g. PROMATECT-H) → see page 87
Ablative Coated Batt System HILTI*
- 6 Mineral wool board - min. density 140 kg/m³ (HILTI CFS-CT B 1S 140/50...)
- 7 Fire stop coating - th. 1 mm (HILTI CFS-CT...) - coating is overcoated on the support construction and on the damper casing/duct
- 8 Fire-resistant mastic - (HILTI CFS-S ACR...) fill the gap from both sides of the fire separation construction and around the perimeter of penetration and damper casing

* HILTI system can be replaced by a similar system with the same or higher thickness, density, fire reaction class, tested according to EN 1366-3.

In gypsum wall construction min. EI 30 - mortar or gypsum

EI 30 (v_e) S [V/H]
EI 45 (v_e) S [V/H]

- Standard flexible wall construction min. EI 30 according to EN 1363-1.
- For connection of following duct → see page 77
- The installation opening is lined with a UW/CW profile.

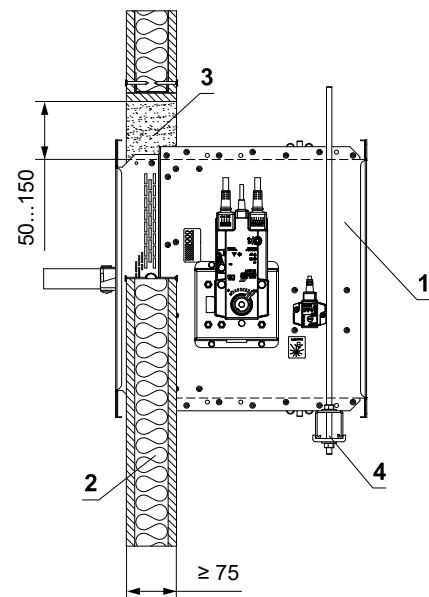
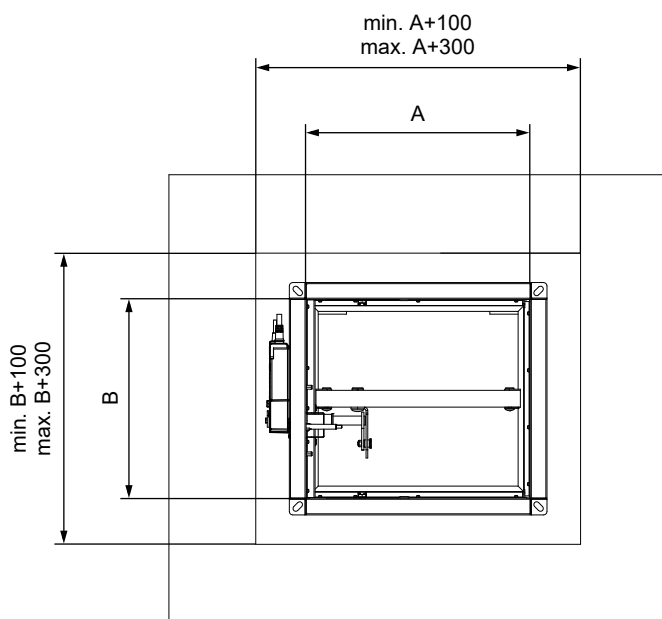
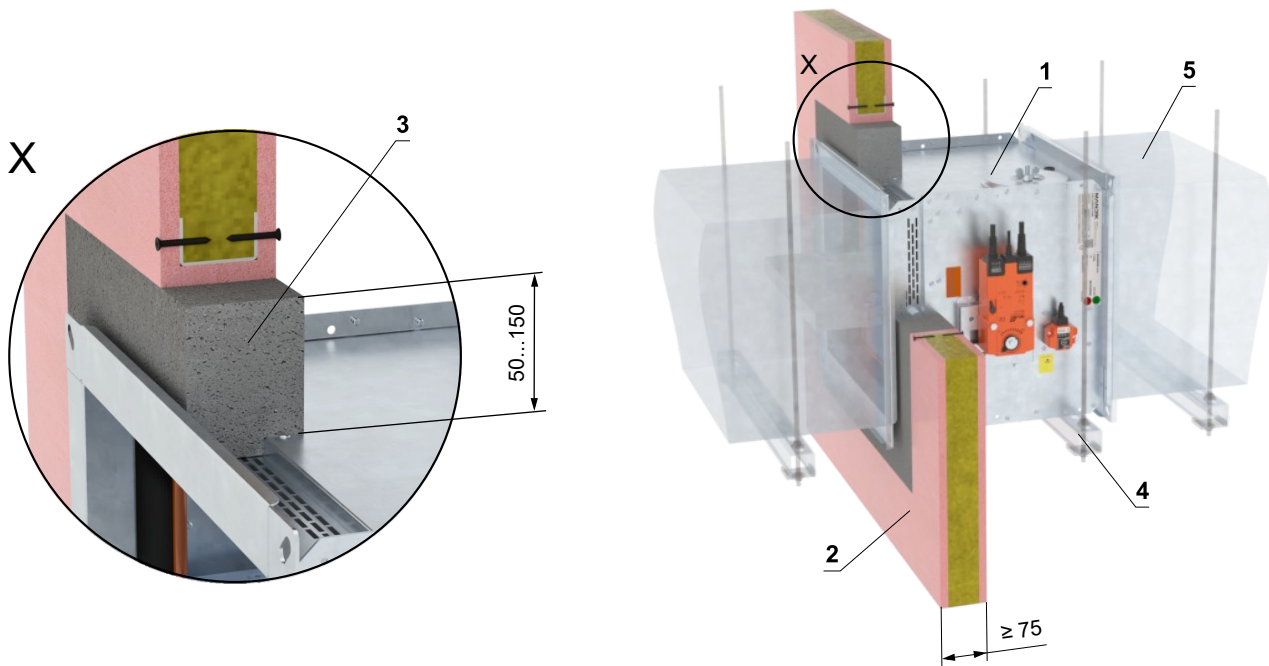

- 1 FDMB
- 2 Gypsum wall construction
- 3 Mortar or gypsum
- 4 Profile with threaded rod → see pages 73 to 76
- 5 Duct

In gypsum wall construction min. EI 30 - Ablative Coated Batt - 50 mm

**EI 30 (ve) S [V/H]
EI 45 (ve) S [V/H]**

- Standard flexible wall construction min. EI 30 according to EN 1363-1.
- For connection of following duct → see page 77
- The installation opening is lined with a UW/CW profile.

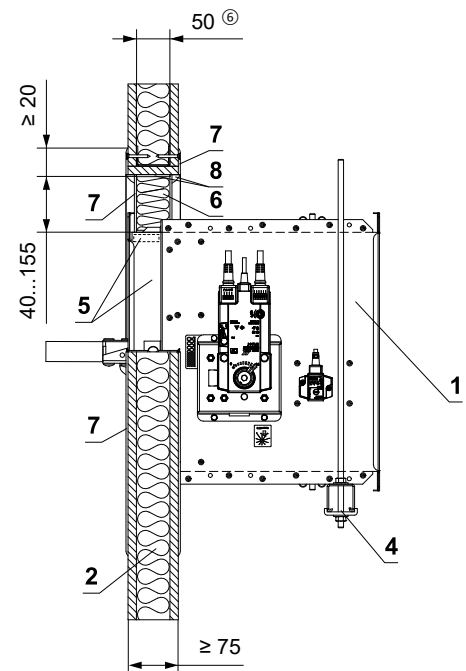
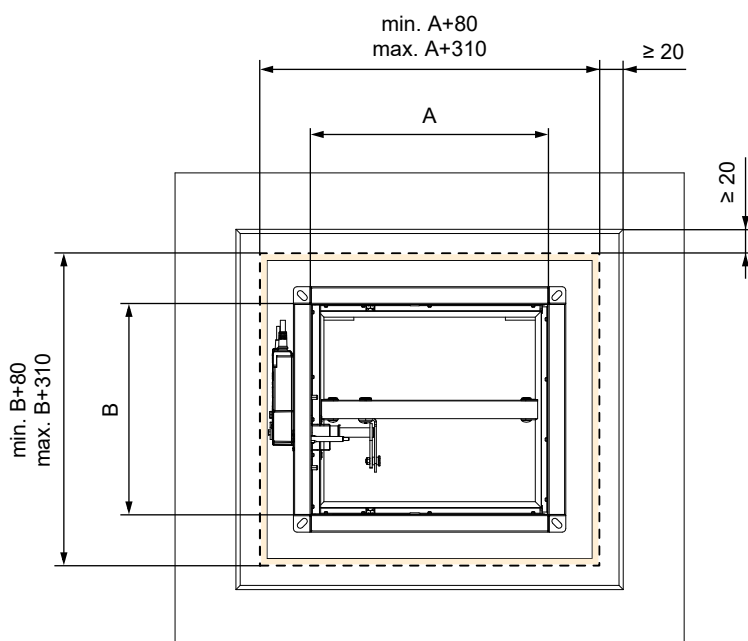
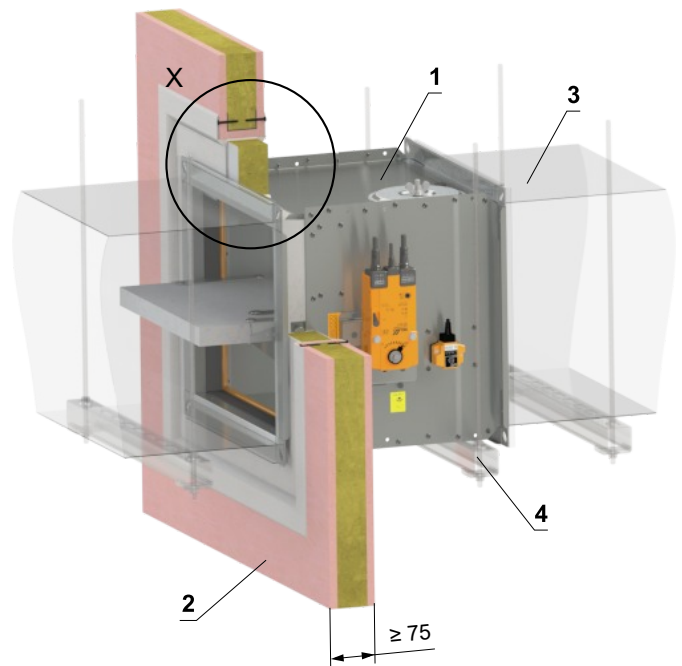
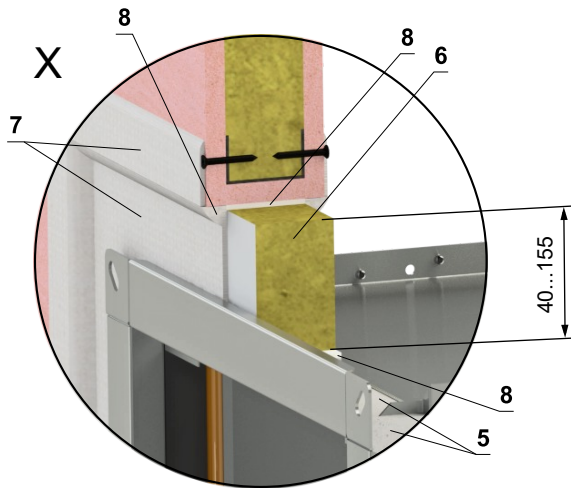

- 1 FDMB
- 2 Gypsum wall construction
- 3 Duct
- 4 Profile with threaded rod → see pages 73 to 76
- 5 Protective cladding board - min. th. 10 mm, min. density 870 kg/m³ (e.g. PROMATECT-H) → see page 87
Ablative Coated Batt System HILTI*
- 6 Mineral wool board - min. density 140 kg/m³ (HILTI CFS-CT B 1S 140/50...)
- 7 Fire stop coating - th. 1 mm (HILTI CFS-CT...) - coating is overcoated on the support construction and on the damper casing/duct
- 8 Fire-resistant mastic - (HILTI CFS-S ACR...) fill the gap from both sides of the fire separation construction and around the perimeter of penetration and damper casing

* HILTI system can be replaced by a similar system with the same or higher thickness, density, fire reaction class, tested according to EN 1366-3.

Installation outside gypsum wall construction

Outside gypsum wall construction min. EI 90 - ISOVER Ultimate Protect - Ablative Coated Batt

EI 90 (v_e) S [V/H]

- Standard flexible wall construction min. EI 90 according to EN 1363-1.
- For connection of following duct → see page 77
- Minimum and maximum distance between the wall and fire damper is unlimited
- When installing the insulation, follow the ISOVER manufacturer's instructions
- The damper and the duct must be suspended separately
- The duct must be suspended on both sides of damper acc. to national rules
- Duct between fire damper and fire separating construction must be suspended by using threaded rods and mounting profiles, or another mounting system acc. to national standards
- Load of the suspension system depends on weight of the fire damper and duct system → see page 73
- Max. distance between two suspension systems is 1500 mm
- Duct at the point of penetration must be fixed to the fire separation structure
- Following air-conditioning duct must be suspended or supported so that all load transfer from the following duct to the fire damper is absolutely excluded. Adjacent duct must be suspended or supported, as required by the duct suppliers
- Damper inspection holes are covered with insulation, therefore it's necessary to make an inspection hole on the connecting duct
- If the threaded rod is located inside the duct insulation, distance between threaded rod and duct is max 30 mm
- If the threaded rod is located outside the duct isolation, distance between threaded rod and isolation is max. 40 mm
- For this installation VRM2-B reinforcement frame must be used → see page 86
- The installation opening is lined with a UW/CW profile.

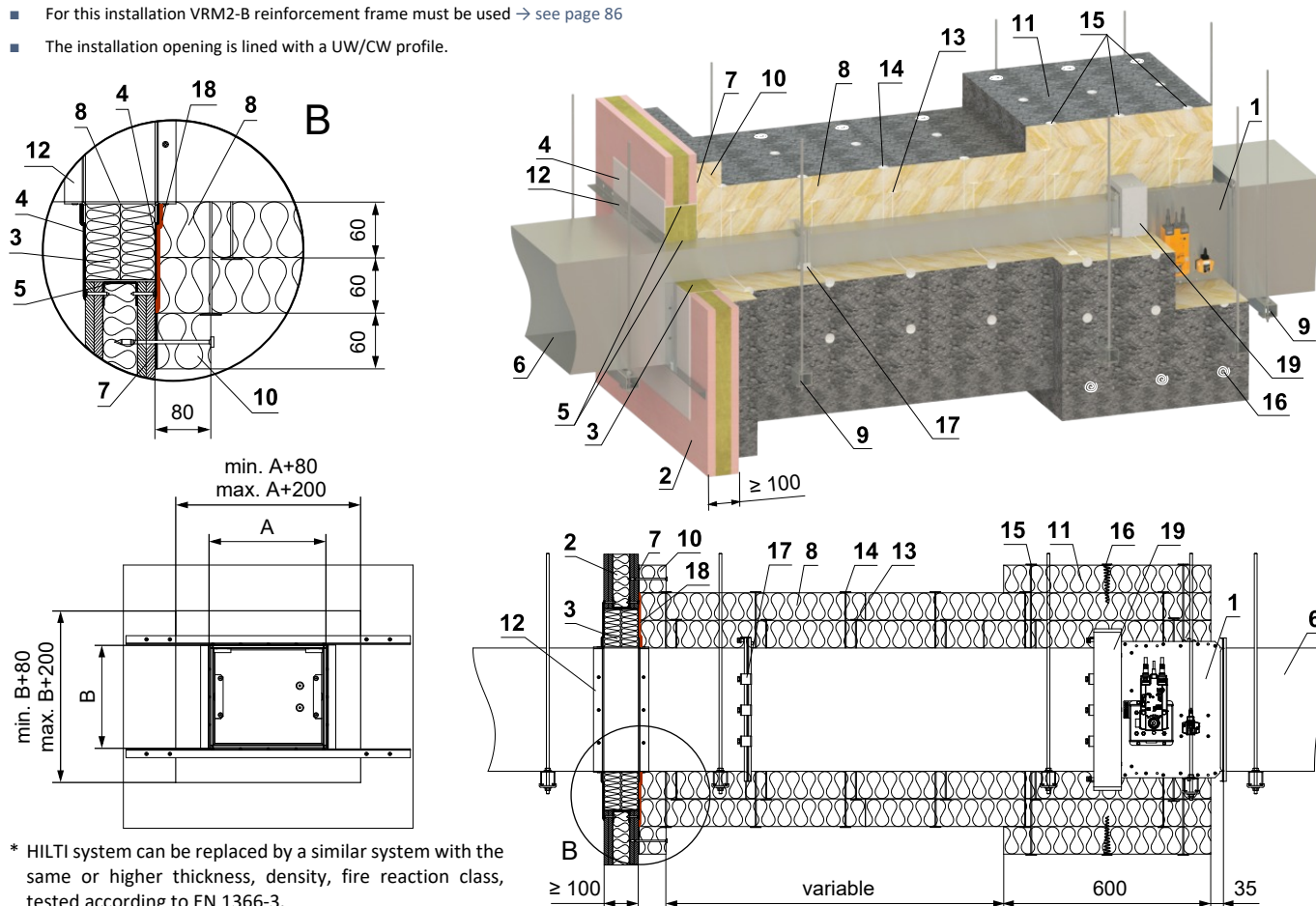

* HILTI system can be replaced by a similar system with the same or higher thickness, density, fire reaction class, tested according to EN 1366-3.

- | | |
|---|---|
| <ol style="list-style-type: none"> 1 FDMB 2 Solid wall construction
Ablative Coated Batt System HILTI* 3 Mineral wool board - min. density 140 kg/m³ (HILTI CFS-CT B 1S 140/50...) 4 Fire stop coating - th. 1 mm (HILTI CFS-CT...) - coating is overcoated on the support construction and on the damper casing/duct 5 Fire-resistant mastic - (HILTI CFS-S ACR...) fill the gap from both sides of the fire separation construction and around the perimeter of penetration and damper casing 6 Standard air duct, made of galvanized sheet metal, thickness according to damper size 7 ISOVER Protect BSK glue - apply on the insulation and fix it to the fire separation construction 8 Insulation board made of mineral wool, with a surface treatment of aluminum foil, thickness 60 mm, min. density 66 kg/m³ (System ISOVER Ultimate Protect Wired Mat 4.0 Alu1) | <ol style="list-style-type: none"> 9 Profile with threaded rod → see pages 73 to 76 10 Duct penetration insulation collar - th. 60 mm - ISOVER Ultimate Protect SLAB 4.0 Alu1, - glued (pos. 7) and fixed with screws to the wall construction 11 Insulating collar of the damper and duct connection - th. 60 mm ISOVER Ultimate Protect SLAB 4.0 Alu1 12 L-profile 30x30x3 mm - installation acc. to ISOVER 13 Stud-welded pin 60 mm - quantity and placing acc. to ISOVER 14 Stud-welded pin 120 mm - quantity and placing acc. to ISOVER 15 Stud-welded pin 180 mm - quantity and placing acc. to ISOVER 16 Fire spiral shaped screw - quantity and placing acc. to ISOVER 17 Steel clamp min. bolt M8 18 ISOVER Protect BSF 19 VRM2-B → see page 86 |
|---|---|

Outside gypsum wall construction min. EI 90 - ISOVER Ultimate Protect - Ablative Coated Batt

EI 60 (ve) S [V/H]

- Standard flexible wall construction min. EI 90 according to EN 1363-1.
- For connection of following duct → see page 77
- Minimum and maximum distance between the wall and fire damper is unlimited
- When installing the insulation, follow the ISOVER manufacturer's instructions
- The damper and the duct must be suspended separately
- The duct must be suspended on both sides of damper acc. to national rules
- Duct between fire damper and fire separating construction must be suspended by using threaded rods and mounting profiles, or another mounting system acc. to national standards
- Load of the suspension system depends on weight of the fire damper and duct system → see page 73
- Max. distance between two suspension systems is 1500 mm
- Duct at the point of penetration must be fixed to the fire separation structure
- Following air-conditioning duct must be suspended or supported so that all load transfer from the following duct to the fire damper is absolutely excluded. Adjacent duct must be suspended or supported, as required by the duct suppliers
- If the threaded rod is located inside the duct insulation, distance between threaded rod and duct is max 30 mm
- If the threaded rod is located outside the duct insulation, distance between threaded rod and isolation is max. 40 mm
- The installation opening is lined with a UW/CW profile.

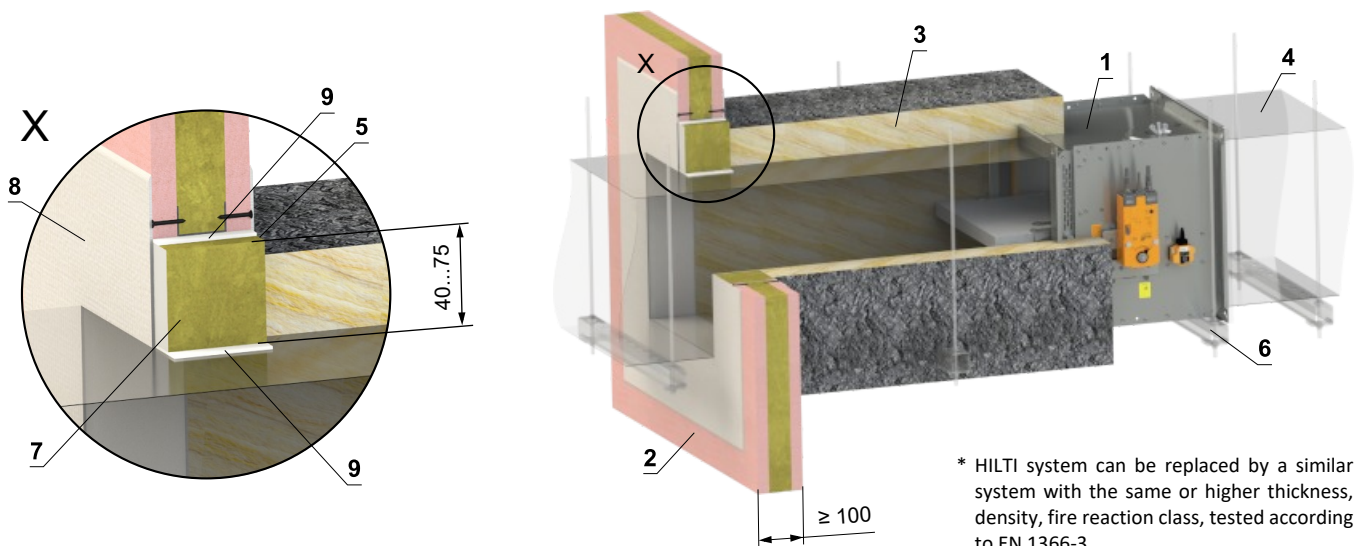

* HILTI system can be replaced by a similar system with the same or higher thickness, density, fire reaction class, tested according to EN 1366-3.

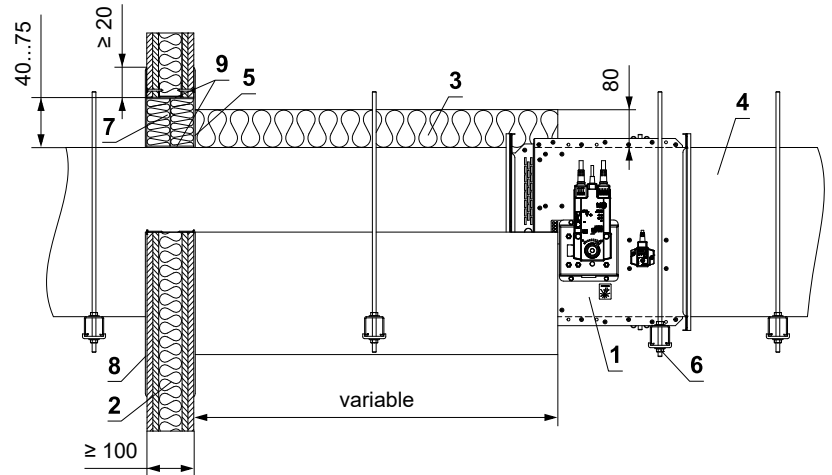
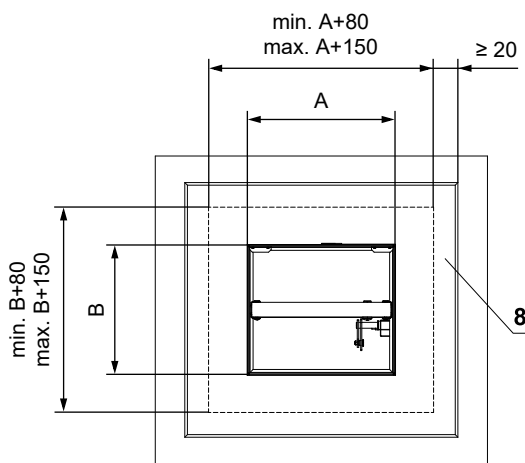

- 1 FDMB
- 2 Gypsum wall construction
- 3 Insulation board made of mineral wool, with a surface treatment of aluminum foil, min. thickness 80 mm, min. density 66 kg/m³ (System ISOVER Ultimate Protect Wired Mat 4.0 Alu1)
- 4 Standard air duct, made of galvanized sheet metal, thickness according to damper size
- 5 ISOVER Protect BSK glue - apply on the insulation and fix it to the fire separation construction
- 6 Profile with threaded rod → see pages 73 to 76
Ablative Coated Batt System HILTI*
- 7 Mineral wool board - min. density 140 kg/m³ (HILTI CFS-CT B 1S 140/50...)
- 8 Fire stop coating - th. 1 mm (HILTI CFS-CT...) - coating is overcoated on the support construction and on the damper casing/duct
- 9 Fire-resistant mastic - (HILTI CFS-S ACR...) fill the gap from both sides of the fire separation construction and around the perimeter of penetration and damper casing

Outside gypsum wall construction min. EI 90 - mineral wool ROCKWOOL - mineral wool with fire-resistant coating and fire-resistant board

EI 90 (v_e) S [V/H]
***EI 120 (v_e) S [V/H]**

- Standard flexible wall construction min. EI 90 according to EN 1363-1.
- For connection of following duct → see page 77
- Minimum and maximum distance between the wall and fire damper is unlimited
- When installing the insulation, follow the ROCKWOOL manufacturer's instructions
- The damper and the duct must be suspended separately
- The duct must be suspended on both sides of damper acc. to national rules
- Duct between fire damper and fire separating construction must be suspended by using threaded rods and mounting profiles, or another mounting system acc. to national standards
- Load of the suspension system depends on weight of the fire damper and duct system → see page 73
- Max. distance between two suspension systems is 1500 mm
- Duct at the point of penetration must be fixed to the fire separation structure
- Following air-conditioning duct must be suspended or supported so that all load transfer from the following duct to the fire damper is absolutely excluded. Adjacent duct must be suspended or supported, as required by the duct suppliers
- If the threaded rod is located inside the duct insulation, distance between threaded rod and duct is max 30 mm
- If the threaded rod is located outside the duct isolation, distance between threaded rod and isolation is max. 40 mm
- For this installation VRM-B reinforcement frame must be used → see page 85
- The installation opening is lined with a UW/CW profile.

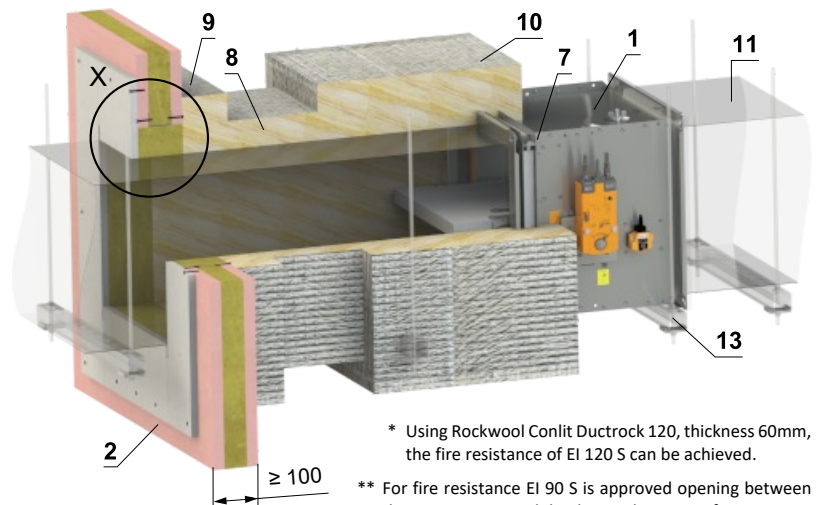
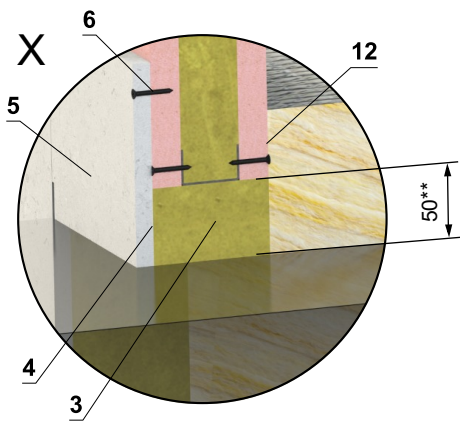

* Using Rockwool Conlit Ductrock 120, thickness 60mm, the fire resistance of EI 120 S can be achieved.

** For fire resistance EI 90 S is approved opening between the construction and the duct in the range of 40...75 mm.

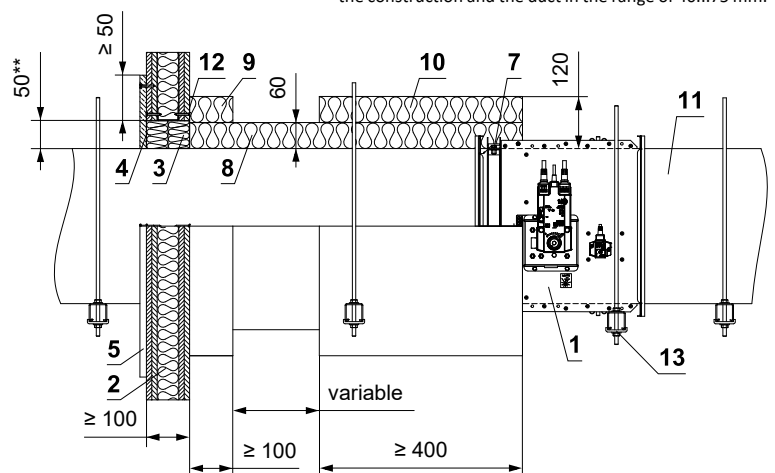
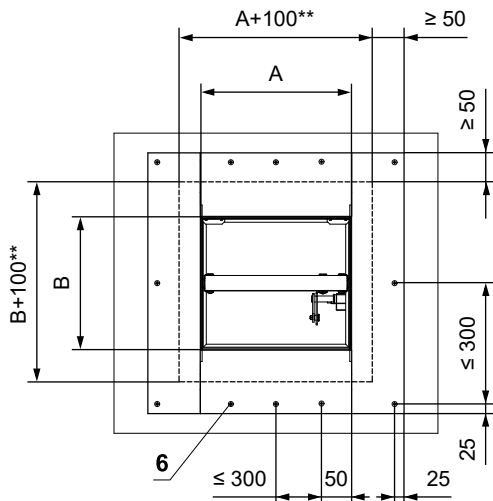

- 1 FDMB
- 2 Gypsum wall construction
- 3 Mineral wool board - min. density 140 kg/m³ (e.g. PROMAPYR-T150, ROCKWOOL HARDROCK / STEPROCK HD)
- 4 Fire-resistant coating - th. 1 mm (e.g. PROMASTOP-I)
- 5 Fire-resistant board - min. th. 15 mm, min. density 870 kg/m³ (e.g. PROMATECT-H)
- 6 Screw 4x50 mm - screws must be fixed in the wall construction, use steel anchors if necessary
- 7 VRM-B → see page 85

- 8 Insulation board made of mineral wool, with a surface treatment of aluminum foil - th. 60 mm, min. density 300 kg/m³ - (System ROCKWOOL Conlit Ductrock 90(120*))
- 9 Duct penetration insulation collar - th. 60 mm (System ROCKWOOL Conlit Ductrock 90(120*)) - glued (pos. 12) and fixed with screws to the wall construction
- 10 Insulation collar of the damper and duct connection - th. 60 mm (System ROCKWOOL Conlit Ductrock 90(120*))
- 11 Standard air duct, made of galvanized sheet metal, thickness according to damper size
- 12 ROCKWOOL Firepro glue - apply on the insulation and fix it to the fire separation construction
- 13 Profile with threaded rod → see pages 73 to 76

In CLT wall construction

In CLT wall construction min. REI 60 - mortar or gypsum

EI 90 (v_e) S [V/H]

- Non-standard CLT wooden wall construction min. REI 60
- Cross laminated timber wall: min. thickness 100 mm, type of wood: European spruce, min. strength class C24, min. fire resistance REI 60, min. reaction to fire D-S2, d0, min. density 380 kg/m³. (e.g. Storaenso SYLVA CLT 100 C3s)
- For connection of following duct → see page 77

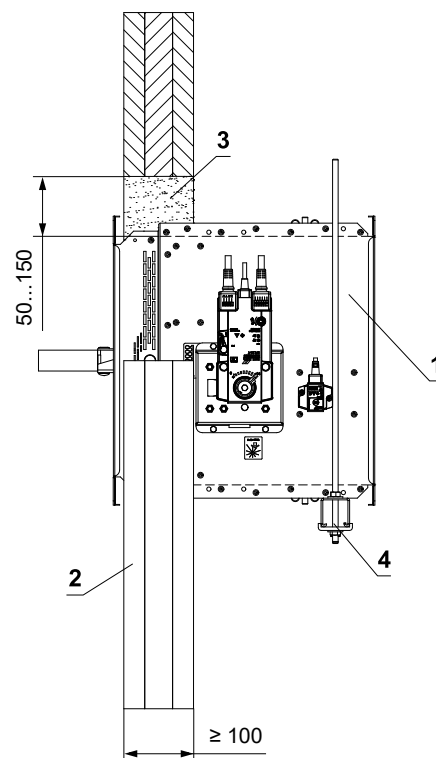
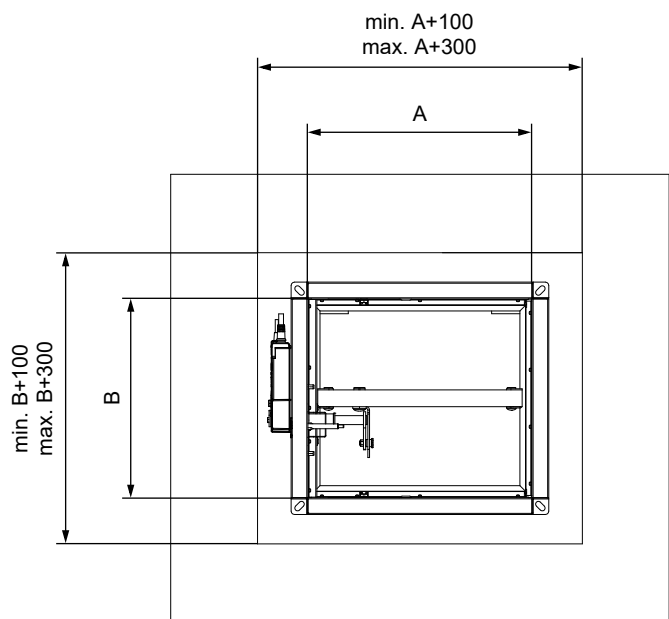
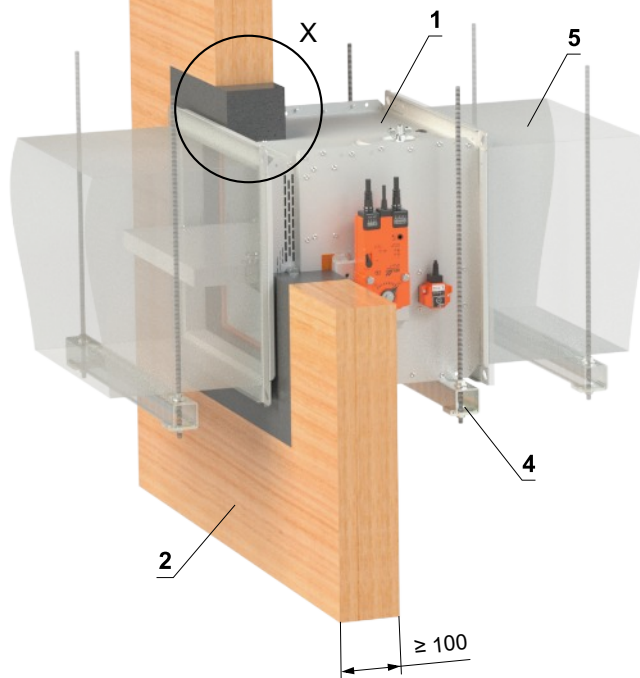
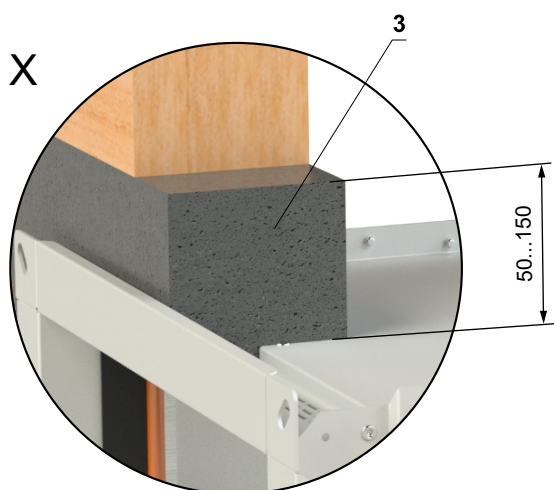

- 1 FDMB
- 2 CLT wall construction
- 3 Mortar or gypsum
- 4 Profile with threaded rod → see pages 73 to 76
- 5 Duct

In CLT wall construction min. REI 60 - Ablative Coated Batt

EI 90 (v_e) S [V/H]

- Non-standard CLT wooden wall construction min. REI 60
- Cross laminated timber wall: min. thickness 100 mm, type of wood: European spruce, min. strength class C24, min. fire resistance REI 60, min. reaction to fire D-S2, d0, min. density 380 kg/m³. (e.g. Storaenso SYLVA CLT 100 C3s)
- For connection of following duct → see page 77

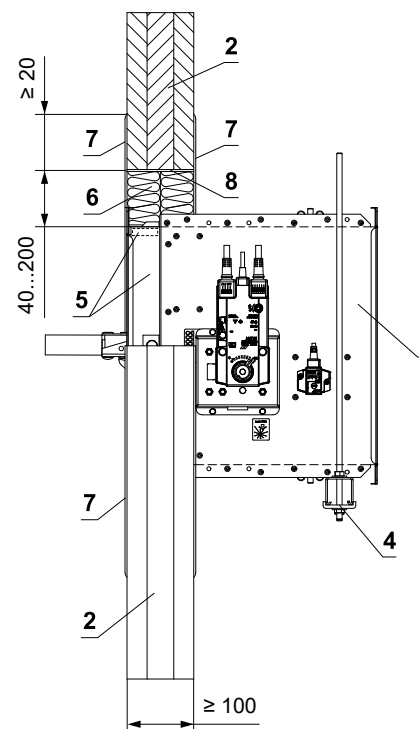
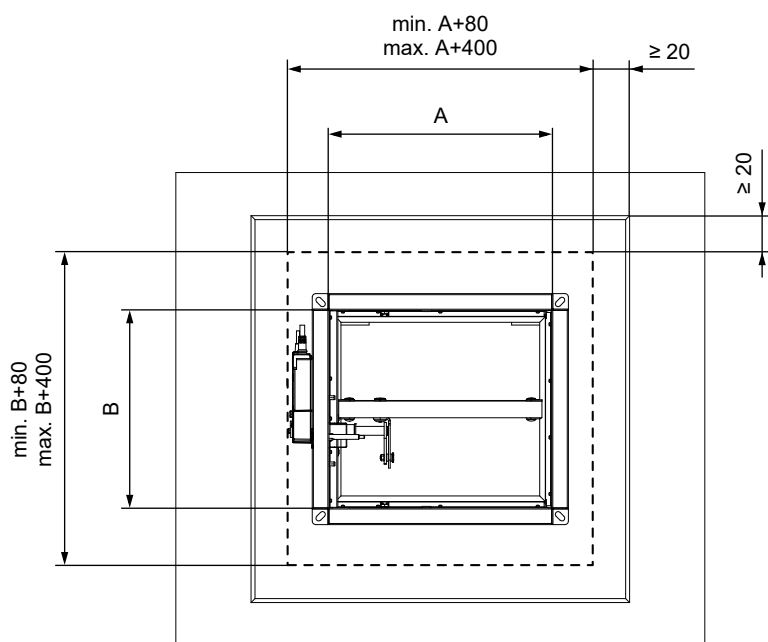
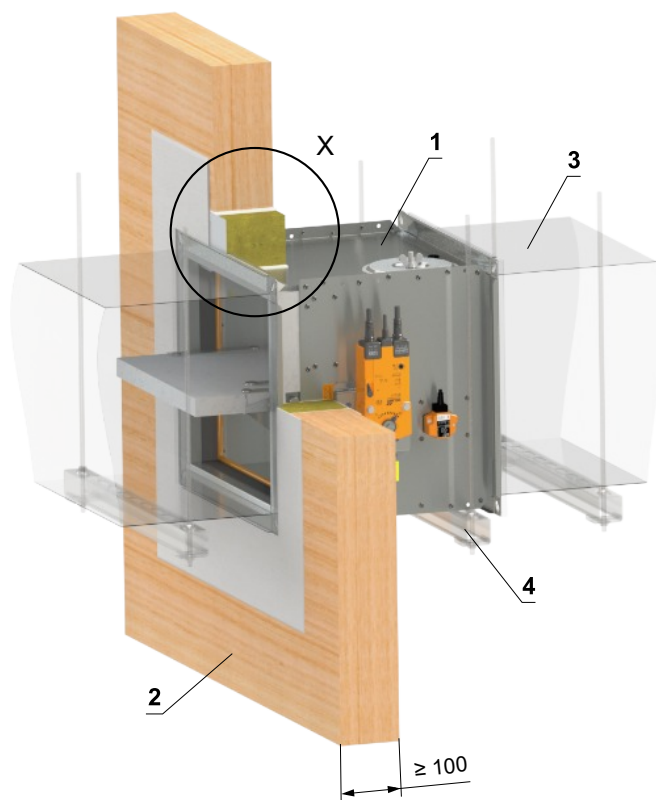
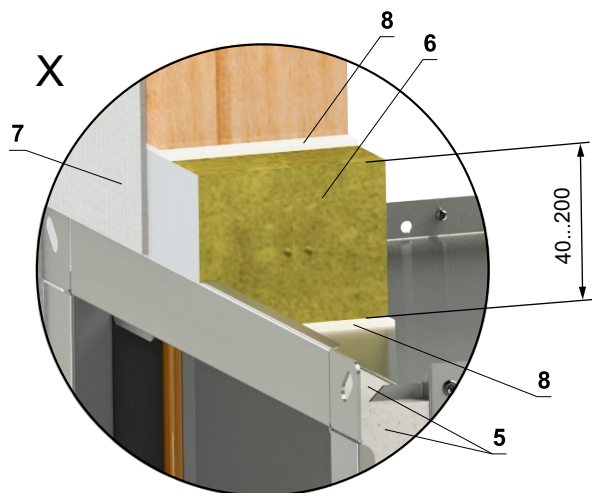

- 1 FDMB
- 2 CLT wall construction
- 3 Duct
- 4 Profile with threaded rod → see pages 73 to 76
- 5 Protective cladding board - min. th. 10 mm, min. density 870 kg/m³ (e.g. PROMATECT-H) → see page 87
Ablative Coated Batt System HILTI*
- 6 Mineral wool board - min. density 140 kg/m³ (HILTI CFS-CT B 1S 140/50...)
- 7 Fire stop coating - th. 1 mm (HILTI CFS-CT...) - coating is overcoated on the support construction and on the damper casing/duct
- 8 Fire-resistant mastic - (HILTI CFS-S ACR...) fill the gap from both sides of the fire separation construction and around the perimeter of penetration and damper casing

* HILTI system can be replaced by a similar system with the same or higher thickness, density, fire reaction class, tested according to EN 1366-3.

In the fire barrier ROCKWOOL Fire Cavity Barrier EN

EI 60 (ve) S [V/H]

- Non-standard lightweight wall construction ROCKWOLL Cavity Barrier EN
- Follow the instructions of ROCKWOOL manufacturer.

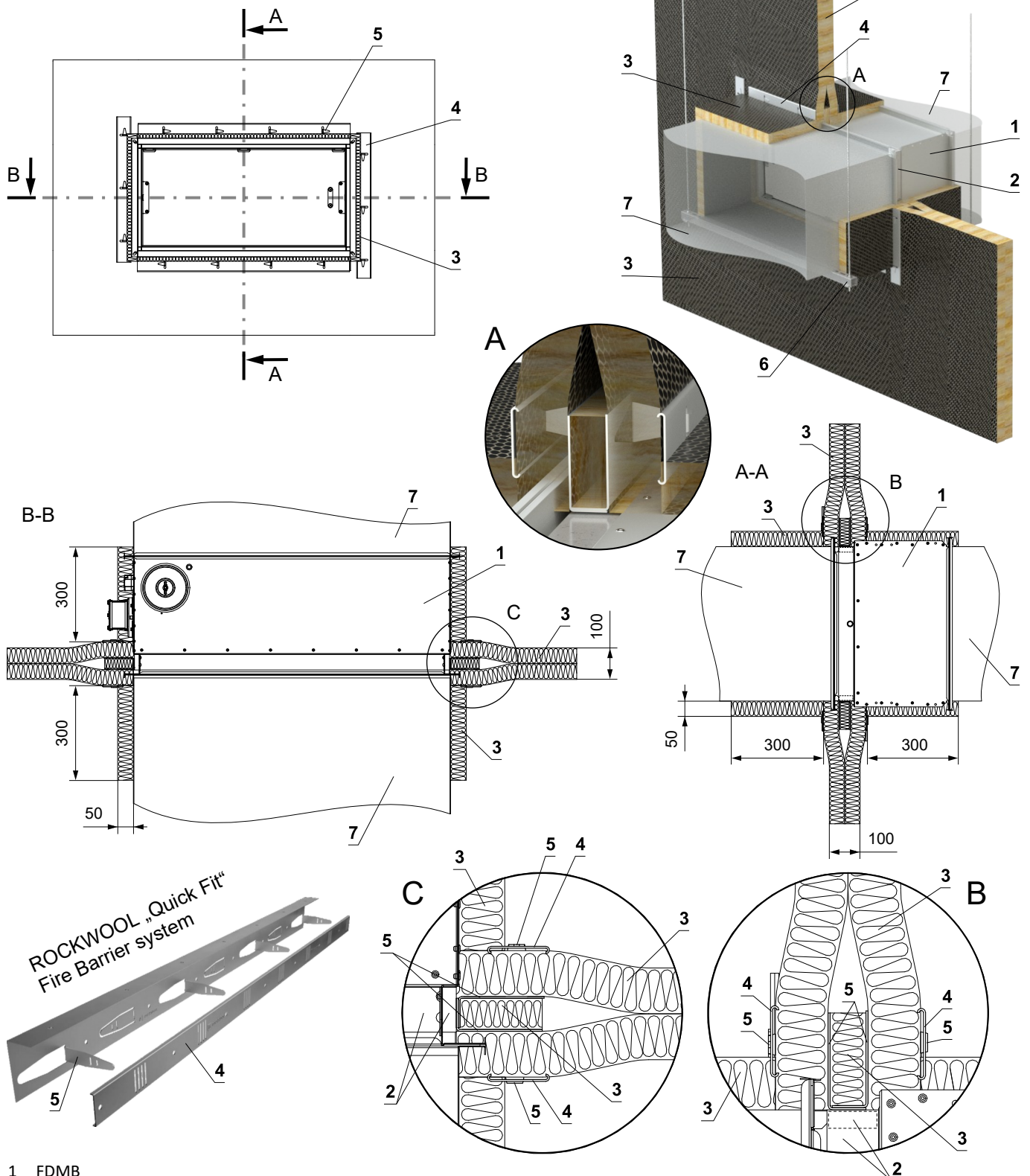

- 1 FDMB
- 2 Protective cladding board - min. th. 10 mm, min. density 870 kg/m³ (e.g. PROMATECT-H) → see page 87
- 3 ROCKWOOL Fire Barrier EN - Stitch all joints of „Fire Barrier EN“ together using steel wire
- 4 Fire Barrier EN Clamping Plate - secure the Fire Barrier insulation with anchor of Angle Support, passing through the insulation - by inserting to hole of Clamping Plate and securing by bending of anchor (sheet metal)
- 5 Fire Barrier EN Angle Support - using 2 pcs of Angle Support make the „U“ channel which secured with screws TEX 4.2x13 mm („U“ channel install around perimeter of damper)
- 6 Profile with threaded rod → see pages 73 to 76
- 7 Duct

In shaft wall construction

EI 60 (v_e) S [V/H]
***EI 90 (v_e) S [V/H]**

In shaft wall construction min. EI 60 - mortar or gypsum

- Non-standard asymm. shaft wall construction, min. EI 60
- For connection of following duct → see page 77
- Damper can be installed on either side of the wall
- It is possible to use e.g. wall type A306002 (EI 60 S), A306003 (EI 90 S)... from www.british-gypsum.com or RNS 103, RNS 104 (EI 60 S)... from www.siniat.co.uk
- It is possible to use walls that have the same or greater thickness and density of boards than the walls listed below (more layers of boards can also be used)
- Follow the instructions of the shaft wall manufacturer.

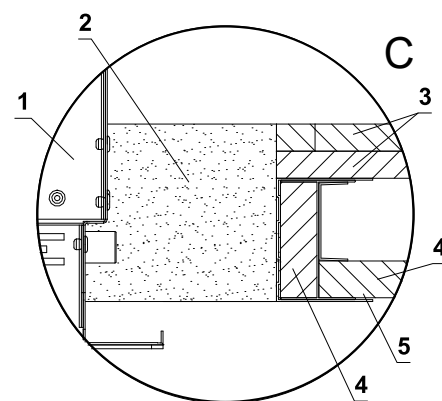
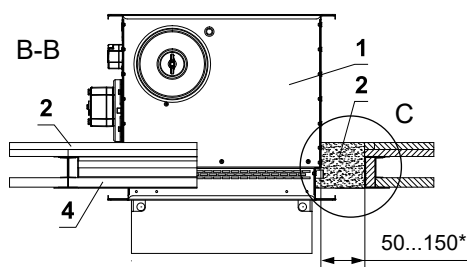
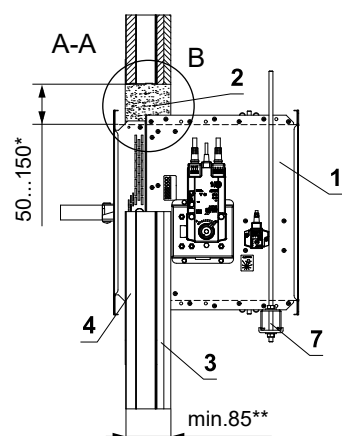
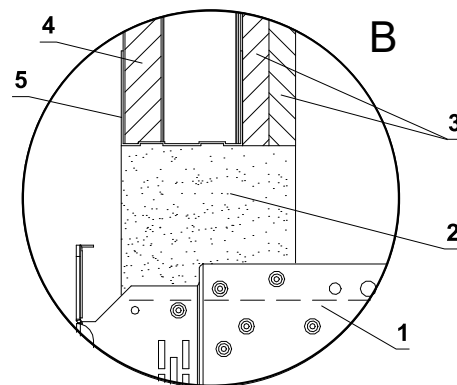
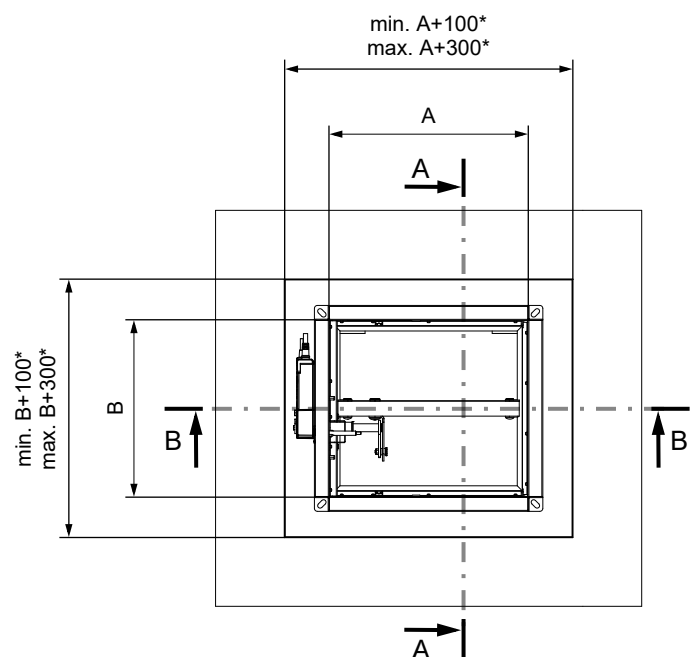
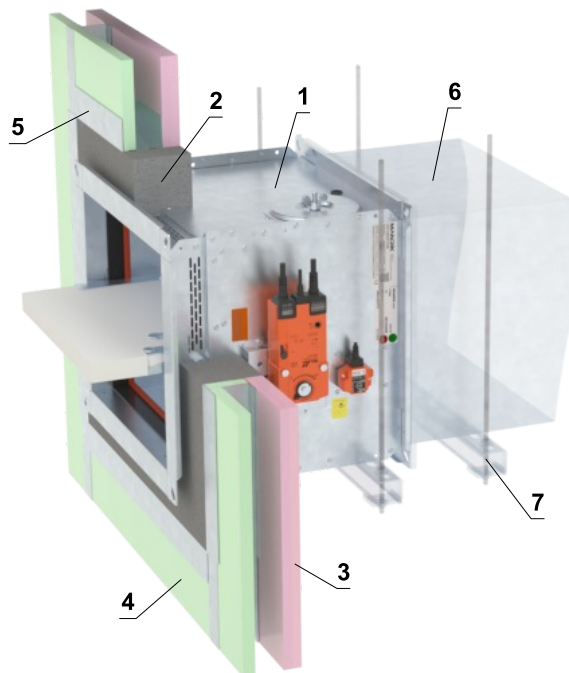

- 1 FDMB
- 2 Mortar or gypsum
- 3 Plasterboard EN 520 - Type F min. 2x12,5 mm**
- 4 Plasterboard EN 520 - Type F min. 1x19 mm**
- 5 Plasteboard profile
- 6 Duct
- 7 Profile with threaded rod → see pages 73 to 76

* In the case of fire resistance EI 90, the installation gap is limited to 50 mm ^{+0/-10}.
 For fire resistance EI 60 or lower, an installation gap range of 50–150 mm is permitted.

** For fire resistance of the shaftwall EI 60 S

In shaft wall construction min. EI 60 - Ablative Coated Batt

EI 60 (ve) S [V/H]
***EI 90 (ve) S [V/H]**

- Non-standard asymm. shaft wall construction, min. EI 60
- For connection of following duct → see page 77
- Damper can be installed on either side of the wall
- It is possible to use e.g. wall type A306002 (EI 60 S), A306003 (EI 90 S)... from www.british-gypsum.com or RNS 103, RNS 104 (EI 60 S)... from www.siniat.co.uk
- It is possible to use walls that have the same or greater thickness and density of boards than the walls listed below (more layers of boards can also be used)
- Follow the instructions of the shaft wall manufacturer.

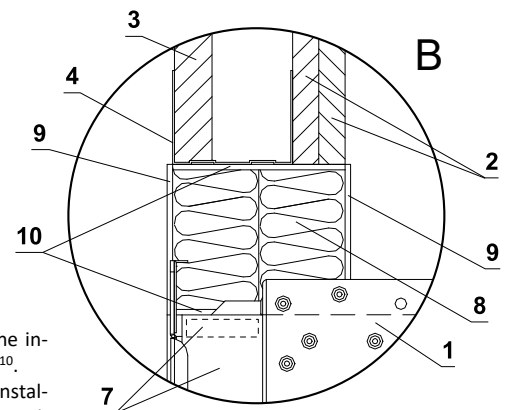
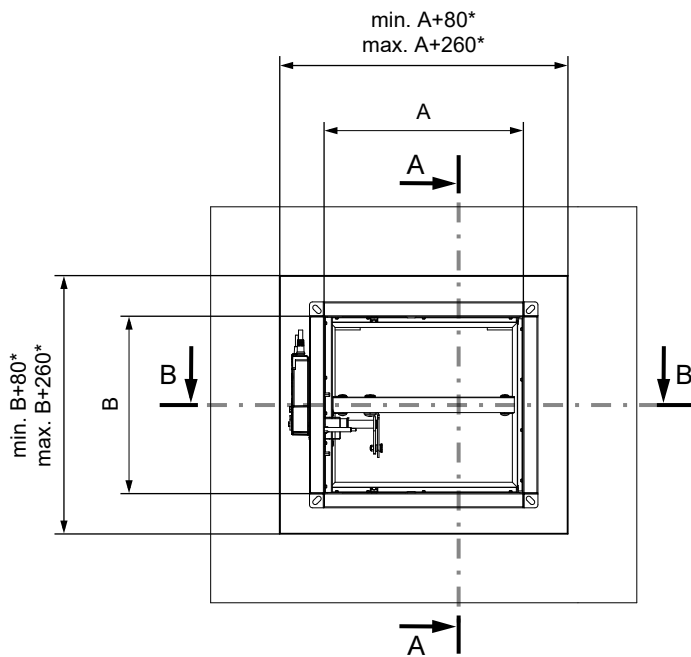
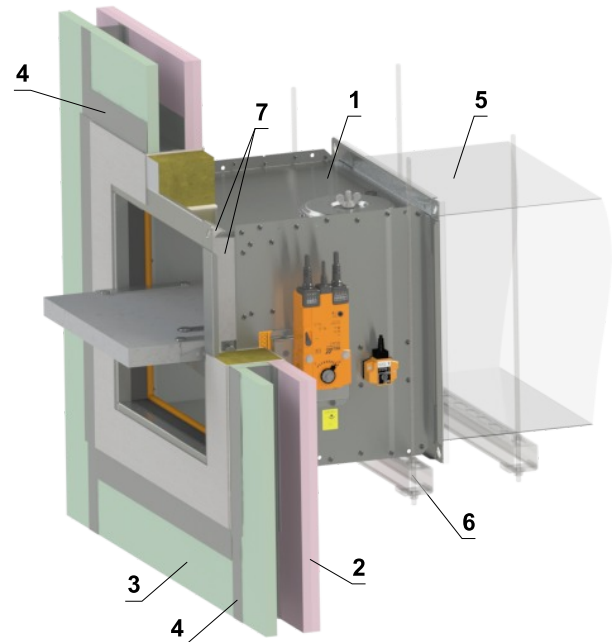

* In the case of fire resistance EI 90, the installation gap is limited to 100 mm ^{+0/-10}. For fire resistance EI 60 or lower, an installation gap range of 40–130 mm is permitted.

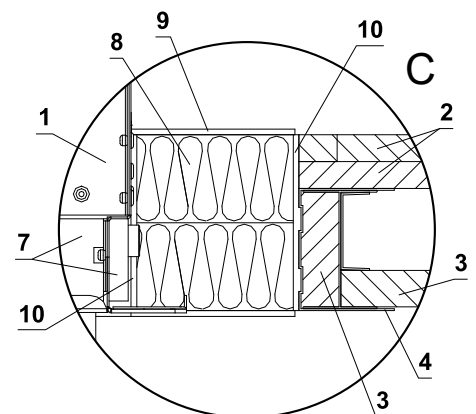
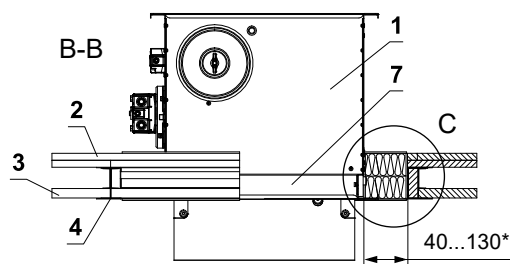
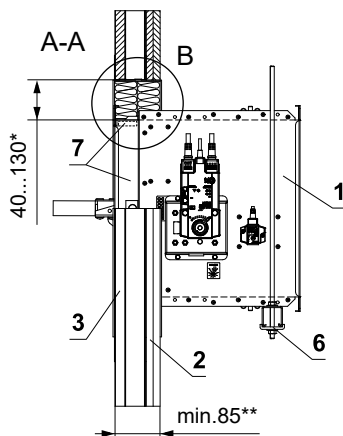

- 1 FDMB
 - 2 Plasterboard EN 520 - Type F min. 2x12,5 mm**
 - 3 Plasterboard EN 520 - Type F min. 1x19 mm**
 - 4 Plasteboard profile
 - 5 Duct
 - 6 Profile with threaded rod → see pages 73 to 76
 - 7 Protective cladding board - min. th. 10 mm, min. density 870 kg/m³ (e.g. PROMATECT-H) → see page 87
Ablative Coated Batt System HILTI***
 - 8 Mineral wool board - min. density 140 kg/m³ (HILTI CFS-CT B 1S 140/50...)
 - 9 Fire stop coating - th. 1 mm (HILTI CFS-CT...) - coating is overcoated on the support construction and on the damper casing/duct
 - 10 Fire-resistant mastic - (HILTI CFS-S ACR...) fill the gap from both sides of the fire separation construction and around the perimeter of penetration and damper casing
- ** For fire resistance of the shaftwall EI 60 S
- *** HILTI system can be replaced by a similar system with the same or higher thickness, density, fire reaction class, tested according to EN 1366-3.

In solid ceiling construction

In solid ceiling construction - mortar or gypsum

- Standard low- and high-density rigid floor construction according to EN 1366-2
- For connection of following duct → see page 77
- The damper can be installed from both sides of the construction, i.e. From the top or the bottom side of the ceiling.

EI 90 (h_o) S [H]
 *EI 120 (h_o) S [H]
 *EI 120 (h_o) S [H] - 500 Pa

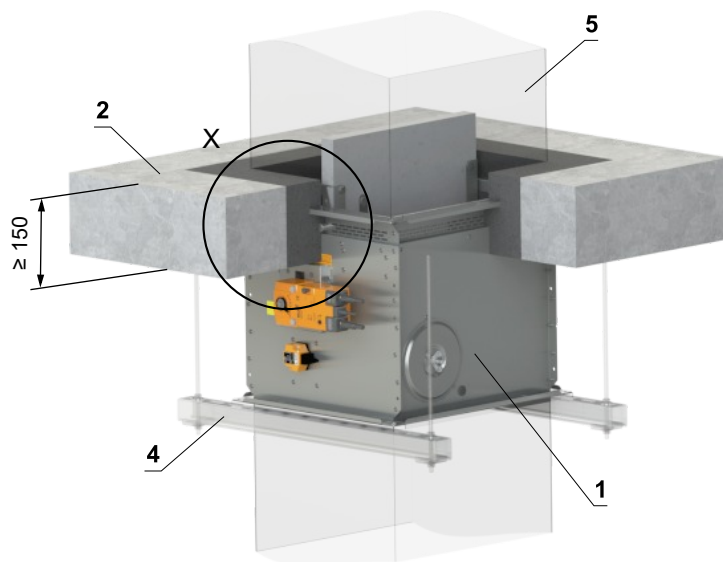
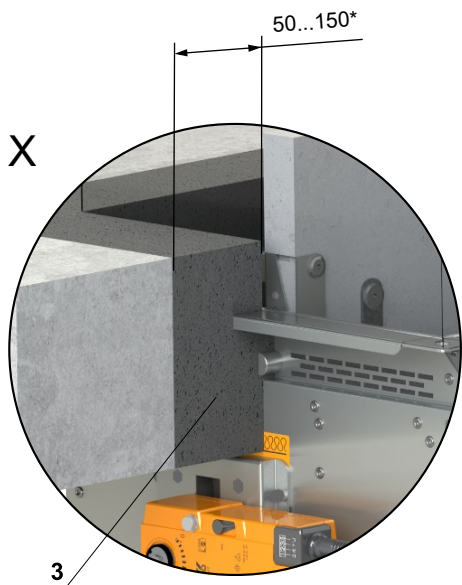

* In the case of fire resistance EI 120, the installation gap is limited to 50 mm ^{+10/-0}.
 For fire resistance EI 90 or lower, an installation gap range of 50–150 mm is permitted.

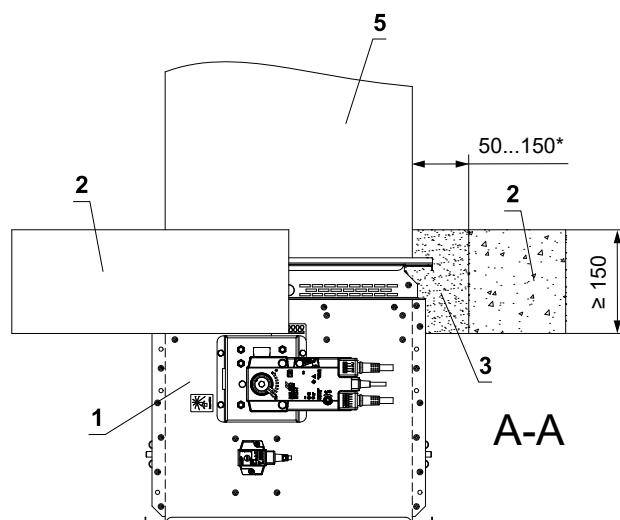
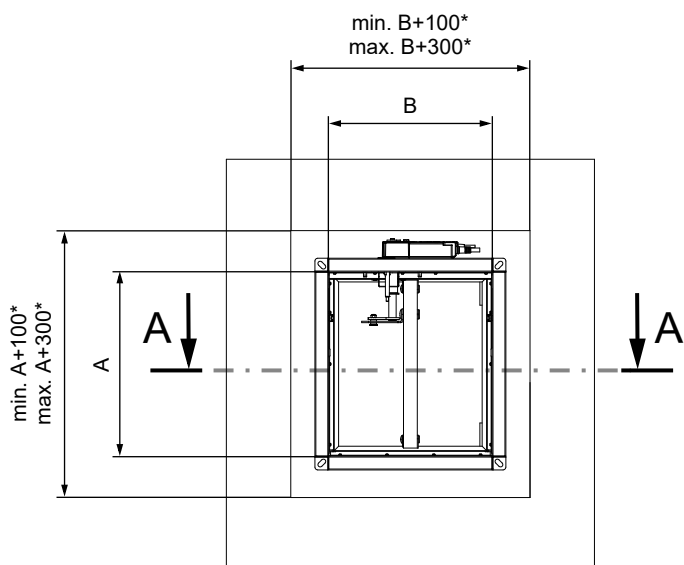

- 1 FDMB
- 2 Solid ceiling construction
- 3 Mortar or gypsum
- 4 Profile with threaded rod → see pages 73 to 76
- 5 Duct

In solid ceiling construction - Ablative Coated Batt

EI 90 (h_o) S [H]

- Standard low- and high-density rigid floor construction according to EN 1366-2
- For connection of following duct → see page 77
- The damper can be installed from both sides of the construction, i.e. From the top or the bottom side of the ceiling.

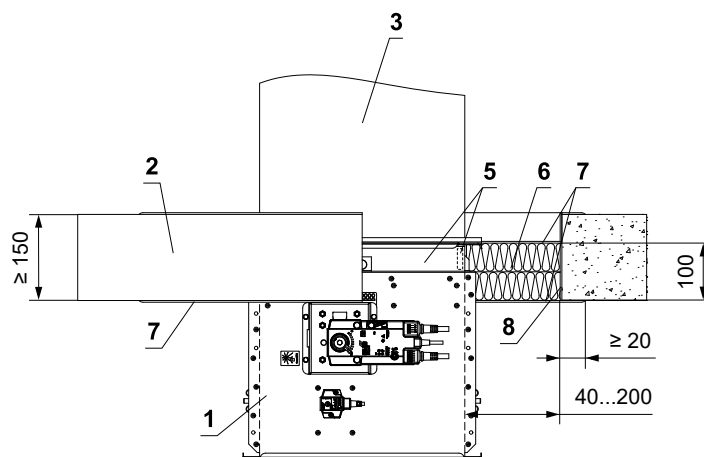
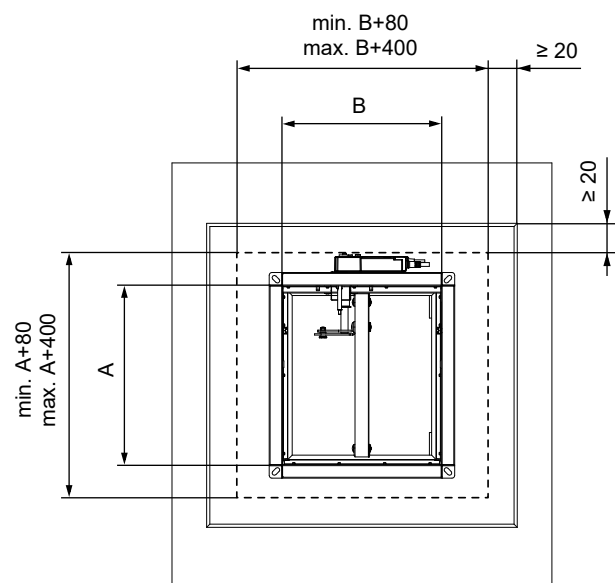
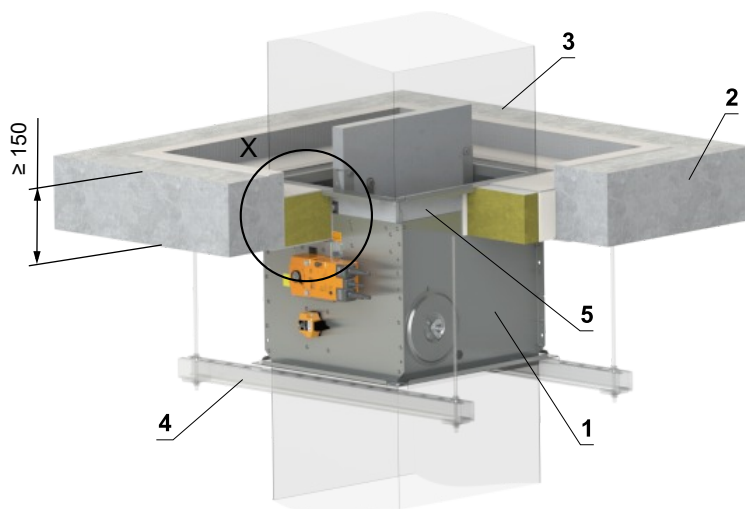
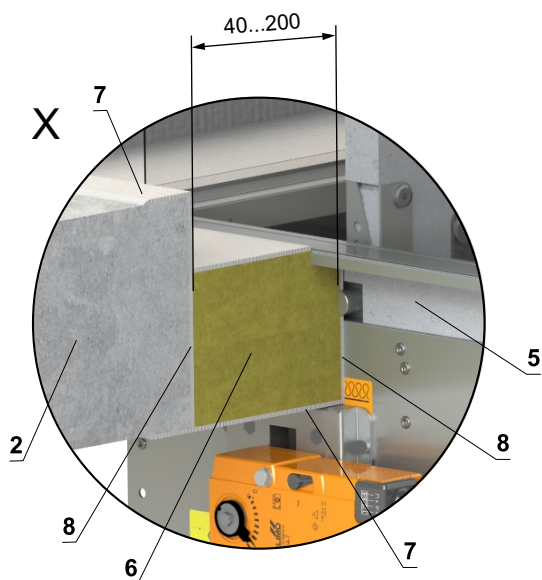

* HILTI system can be replaced by a similar system with the same or higher thickness, density, fire reaction class, tested according to EN 1366-3.

- 1 FDMB
- 2 Solid ceiling construction
- 3 Duct
- 4 Profile with threaded rod → see pages 73 to 76
- 5 Protective cladding board - min. th. 10 mm, min. density 870 kg/m³ (e.g. PROMATECT-H) → see page 87
Ablative Coated Batt System HILTI*
- 6 Mineral wool board - min. density 140 kg/m³ (HILTI CFS-CT B 1S 140/50...)
- 7 Fire stop coating - th. 1 mm (HILTI CFS-CT...) - coating is overcoated on the support construction and on the damper casing/duct
- 8 Fire-resistant mastic - (HILTI CFS-S ACR...) fill the gap from both sides of the fire separation construction and around the perimeter of penetration and damper casing

Outside solid ceiling construction

Outside solid wall construction - mineral wool ROCKWOOL - mortar or gypsum

EI 90 (h_o) S [H]

- Standard low- and high-density rigid floor construction according to EN 1366-2
- For connection of following duct → see page 77
- Minimum and maximum distance between the ceiling and fire damper is unlimited
- When installing the insulation, follow the ROCKWOOL manufacturer's instructions
- The damper and the duct must be suspended separately
- The duct must be suspended on both sides of damper acc. to national rules
- Duct between fire damper and fire separating construction must be suspended by using threaded rods and mounting profiles, or another mounting system acc. to national standards
- Load of the suspension system depends on weight of the fire damper and duct system → see page 73
- Max. distance between two suspension systems is 1500 mm
- Duct at the point of penetration must be fixed to the fire separation structure
- Following air-conditioning duct must be suspended or supported so that all load transfer from the following duct to the fire damper is absolutely excluded. Adjacent duct must be suspended or supported, as required by the duct suppliers
- If the threaded rod is located inside the duct insulation, distance between threaded rod and duct is max 30 mm
- If the threaded rod is located outside the duct isolation, distance between threaded rod and isolation is max. 40 mm
- For this installation VRM-B reinforcement frame must be used → see page 85
- The damper can be installed from both sides of the construction, i.e. from the top or the bottom side of the ceiling.

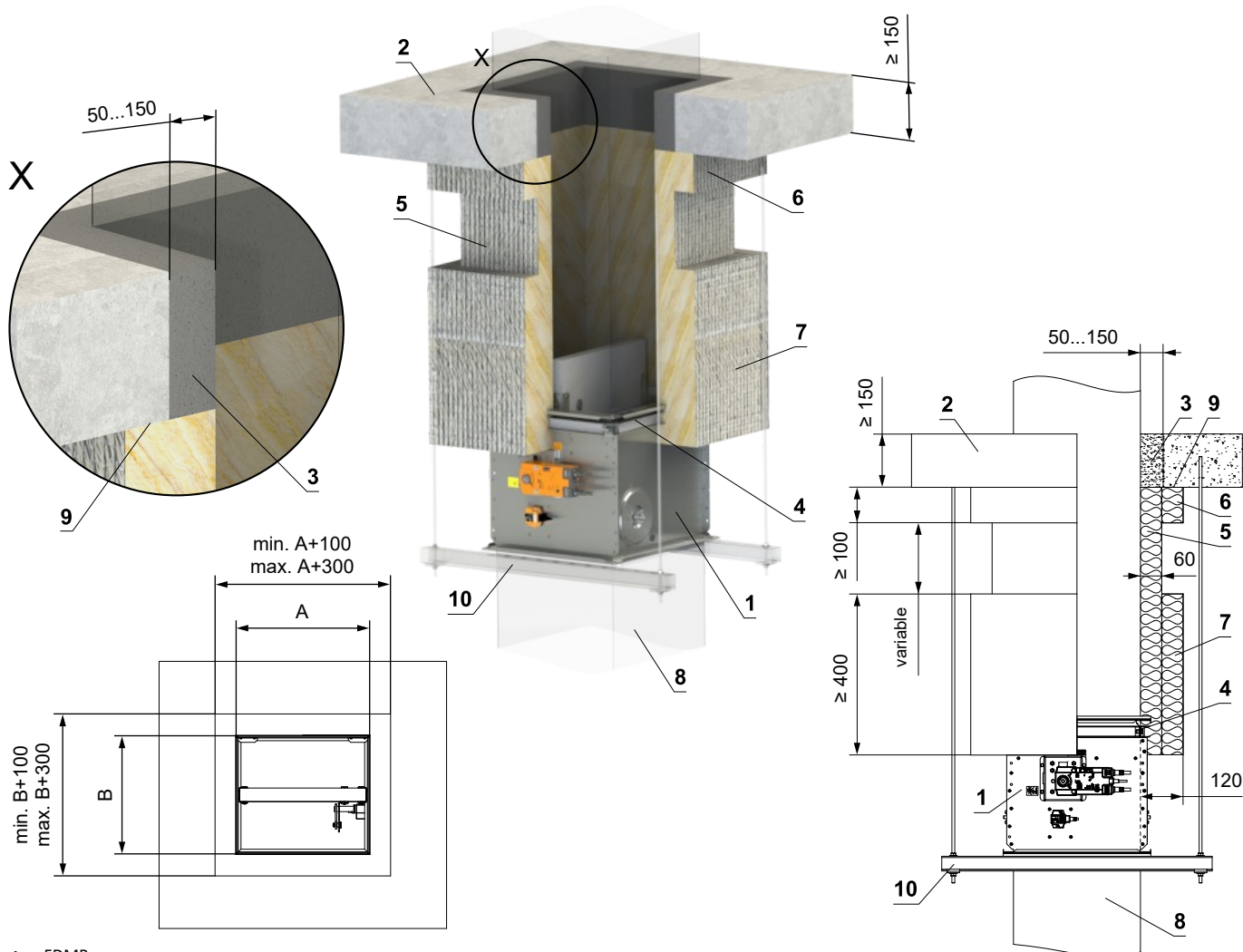

- | | |
|--|--|
| <ol style="list-style-type: none"> 1 FDMB 2 Solid ceiling construction 3 Mortar or gypsum 4 VRM-B → see page 85 5 Insulation board made of mineral wool, with a surface treatment of aluminum foil - th. 60 mm, min. density 300 kg/m³ - (System ROCKWOOL Conlit Ductrock 90) 6 Duct penetration insulation collar - th. 60 mm (System ROCKWOOL Conlit Ductrock 90) - glued (pos. 9) and fixed with screws to the wall construction | <ol style="list-style-type: none"> 7 Insulation collar of the damper and duct connection - th. 60 mm (System ROCKWOOL Conlit Ductrock 90) 8 Standard air duct, made of galvanized sheet metal, thickness according to damper size 9 ROCKWOOL Firepro glue - apply on the insulation and fix it to the fire separation construction 10 Profile with threaded rod → see pages 73 to 76 |
|--|--|

Outside solid ceiling construction - concreting

EI 90 (h_o) S [H]

- Standard low- and high-density rigid floor construction according to EN 1366-2
- For connection of following duct → see page 77
- The duct must be suspended or supported on both sides of the damper acc. to national rules
- Load of the suspension system depends on weight of the fire damper and duct system → see page 73
- Max. distance between two suspension systems is 1500 mm
- Following air-conditioning duct must be suspended or supported so that all load transfer from the following duct to the fire damper is absolutely excluded. Adjacent duct must be suspended or supported, as required by the duct suppliers

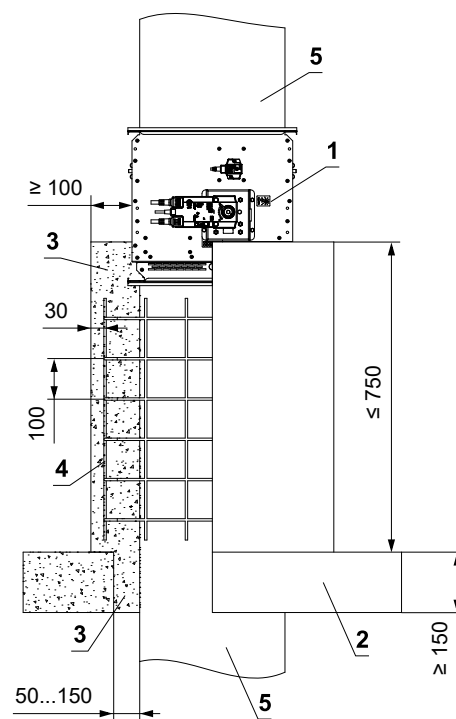
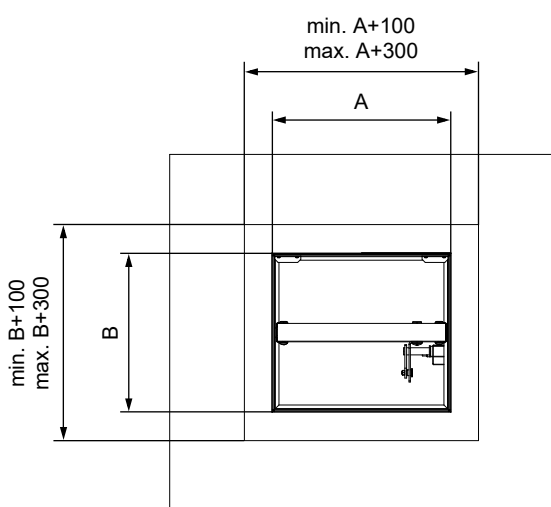
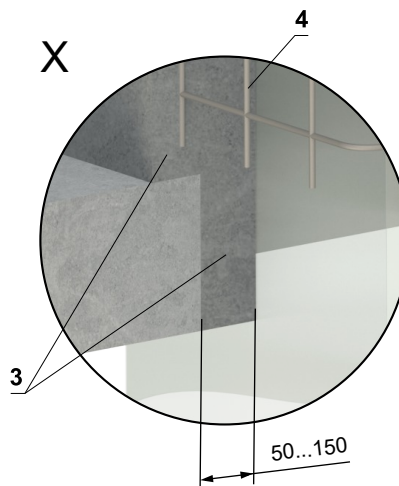
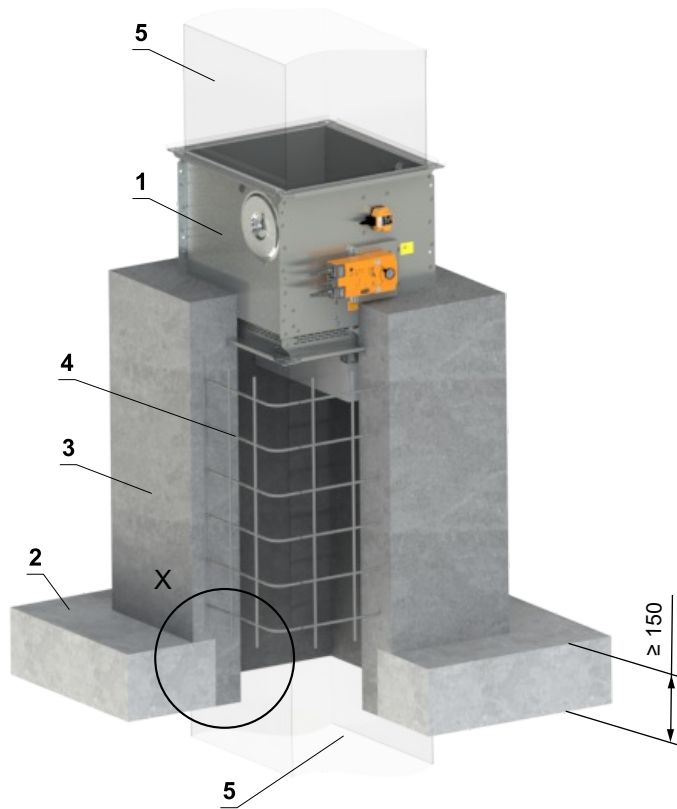

- 1 FDMB
- 2 Solid ceiling construction
- 3 Concrete B20
- 4 Rebar - steel rod \varnothing 6 mm, mesh hole 100 mm
- 5 Standard air duct, made of galvanized sheet metal, thickness according to damper size

In CLT ceiling construction

In CLT ceiling construction min. REI 60 - mortar or gypsum

EI 90 (h_o) S [H]

- Non-standard CLT wooden ceiling construction min. REI 60
- Cross laminated timber floor: min. thickness 140 mm, type of wood: European spruce, min. strength class C24, min. fire resistance REI 60, min. reaction to fire D-S2, d0, min. density 380 kg/m³. (e.g. Storaenso SYLVA CLT 140 L5s)
- For connection of following duct → see page 77
- The damper can be installed from both sides of the construction, i.e. From the top or the bottom side of the ceiling.

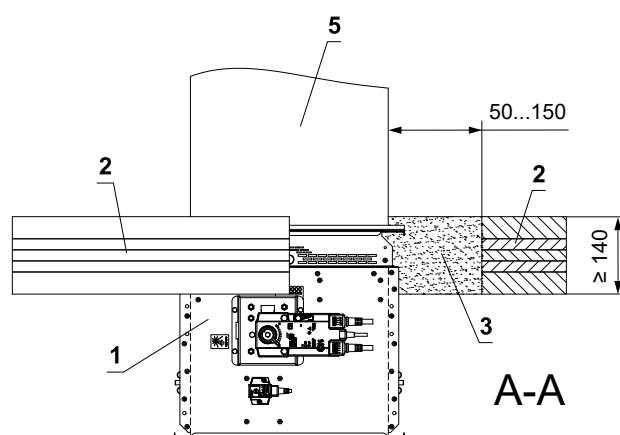
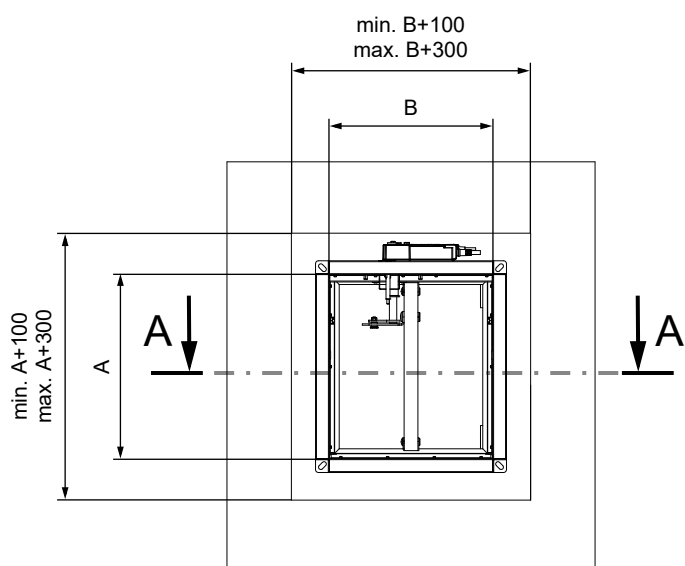
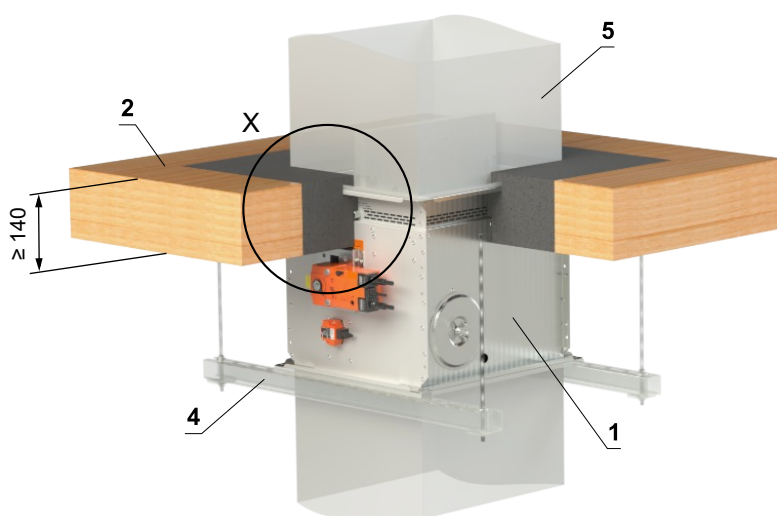
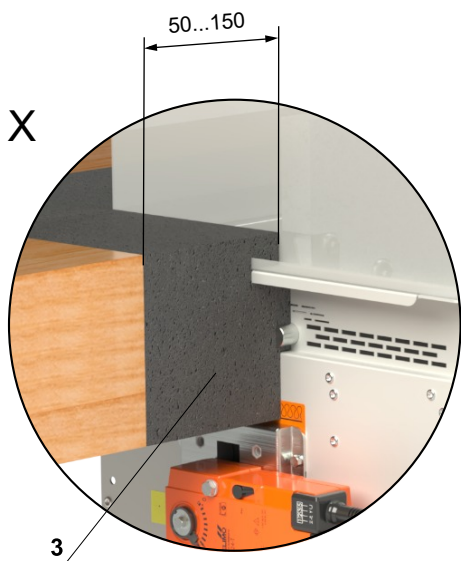

- 1 FDMB
- 2 CLT ceiling construction
- 3 Mortar or gypsum
- 4 Profile with threaded rod → see pages 73 to 76
- 5 Duct

In CLT ceiling construction min. REI 60 - Ablative Coated Batt

EI 90 (h_o) S [H]

- Non-standard CLT wooden ceiling construction min. REI 60
- Cross laminated timber floor: min. thickness 140 mm, type of wood: European spruce, min. strength class C24, min. fire resistance REI 60, min. reaction to fire D-S2, d0, min. density 380 kg/m³. (e.g. Storaenso SYLVA CLT 140 L5s)
- For connection of following duct → see page 77
- The damper can be installed from both sides of the construction, i.e. From the top or the bottom side of the ceiling.

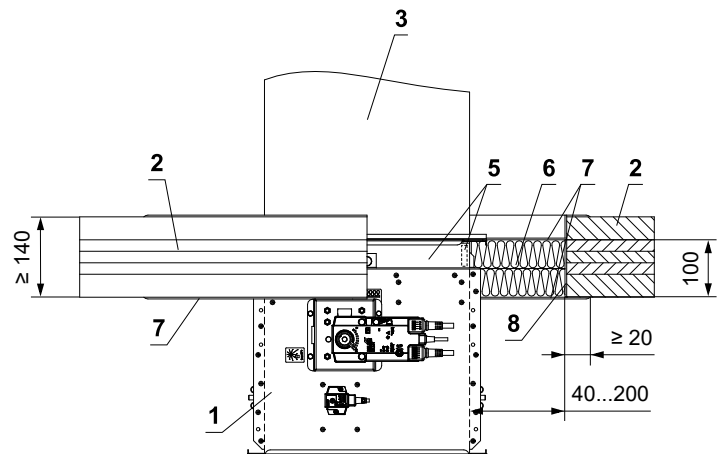
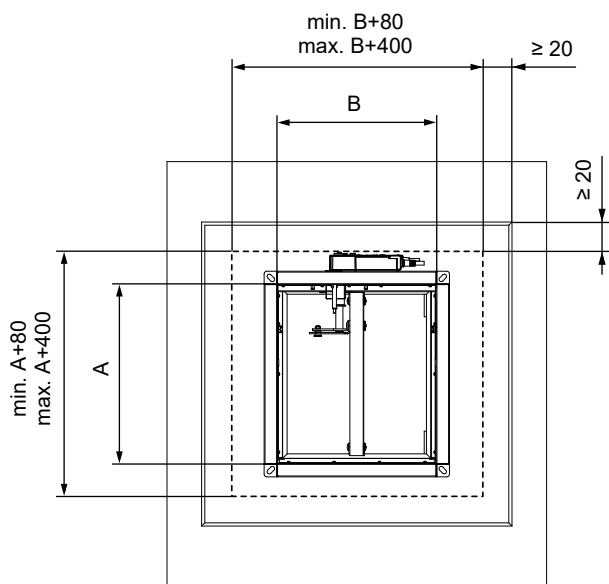
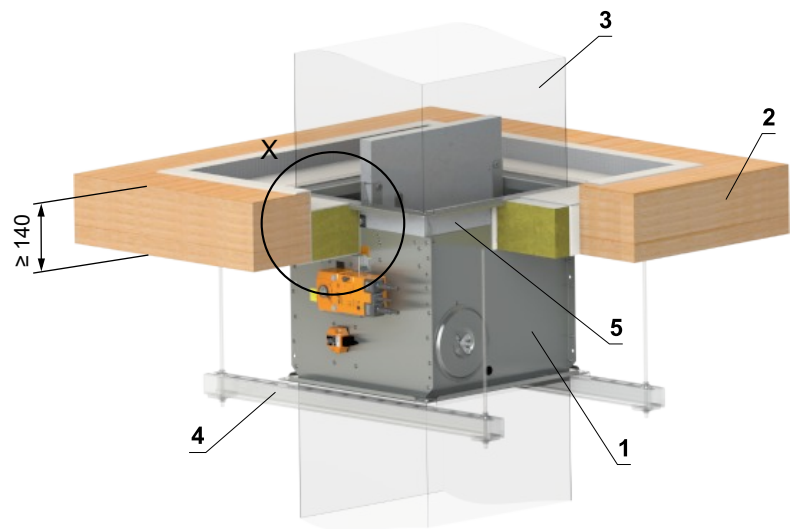
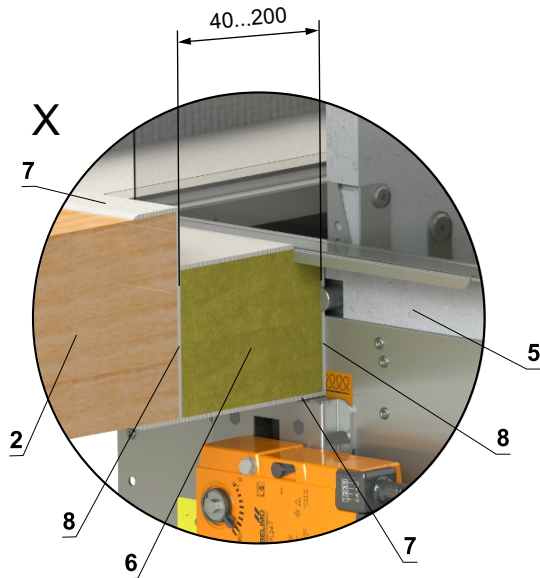

- 1 FDMB
- 2 CLT ceiling construction
- 3 Duct
- 4 Profile with threaded rod → see pages 73 to 76
- 5 Protective cladding board - min. th. 10 mm, min. density 870 kg/m³ (e.g. PROMATECT-H) → see page 87
Ablative Coated Batt System HILTI*
- 6 Mineral wool board - min. density 140 kg/m³ (HILTI CFS-CT B 1S 140/50...)
- 7 Fire stop coating - th. 1 mm (HILTI CFS-CT...) - coating is overcoated on the support construction and on the damper casing/duct
- 8 Fire-resistant mastic - (HILTI CFS-S ACR...) fill the gap from both sides of the fire separation construction and around the perimeter of penetration and damper casing

* HILTI system can be replaced by a similar system with the same or higher thickness, density, fire reaction class, tested according to EN 1366-3.

Installation frames

List of installation frames and installation options

Installation frame	Wall thickness (mm)								
	Solid wall construction			Gypsum wall construction			Solid ceiling construction		
	In construction	Outside construction	On construction	In construction	Outside construction	On construction	In construction	Outside construction	On construction
E1	≥ 100	–	–	≥ 100	–	–	≥ 150	–	–
E2	≥ 100	–	–	–	–	–	≥ 150	–	–
E3	–	–	–	≥ 100	–	–	–	–	–
E4	–	–	≥ 100	–	–	≥ 100	–	≥ 150	≥ 150
E5	–	–	–	≥ 100	–	–	–	–	–
E6	–	≥ 100	–	–	–	–	–	≥ 150	–

Installation frame E1



Installation frame E2

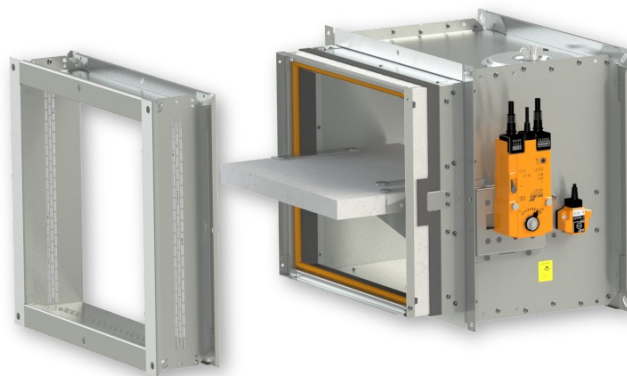

Installation frame E3

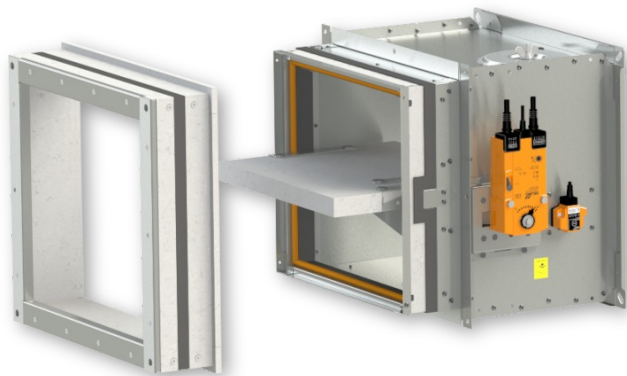

Installation frame E4



Installation frame E5

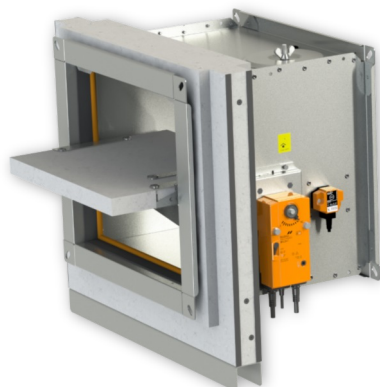

Installation frame E6



- Installation frame can be installed on the damper or delivered separately

Installation frame E1

- Installation frame E1 is designed for installation without additional sealing of the penetration into:
 - Solid wall construction
 - Gypsum wall construction
 - Solid ceiling construction
- Installation frame is equipped with an intumescent sealing on the inside and outside. This sealing fills the gap between the damper casing and frame and between the frame and construction in the event of a fire
- **Solid wall/gypsum wall th. 100 mm or solid ceiling th. 150 mm**
- Material:
 - Installation frame - cement-lime boards
 - Fasteners - galvanized steel

Installation frame E1

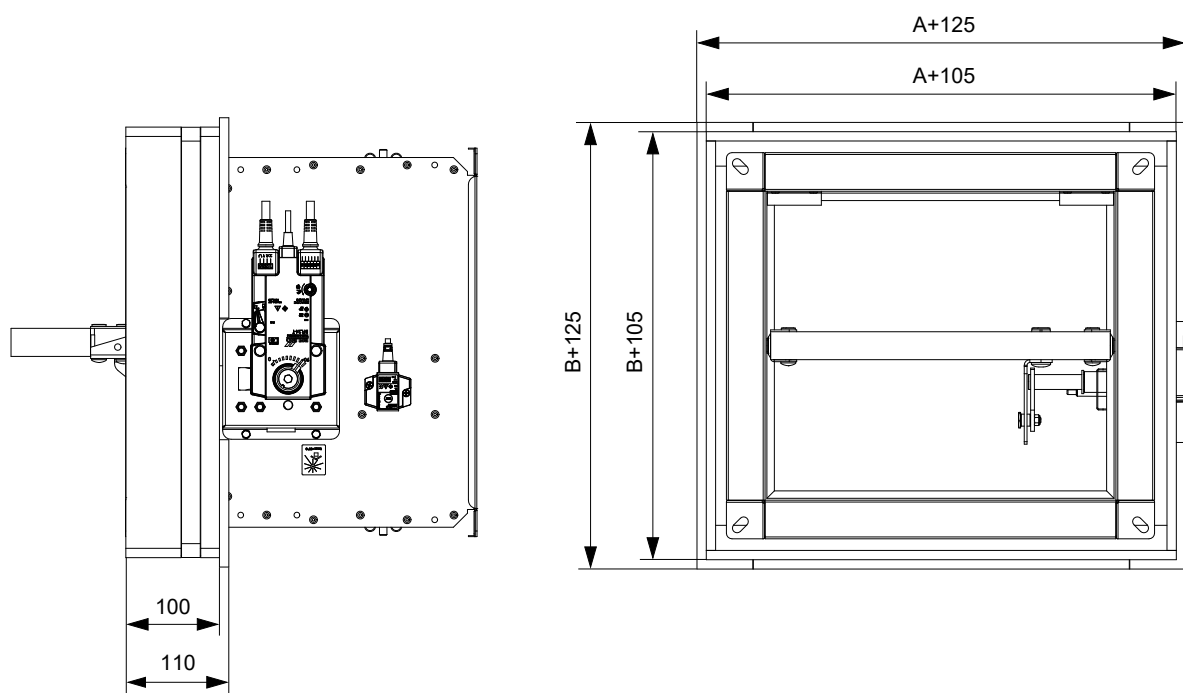

In solid wall construction - installation frame E1

EI 90 (ve) S [V/H]

- For connection of following duct → see page 77
- Installation frame can be installed on the damper or delivered separately

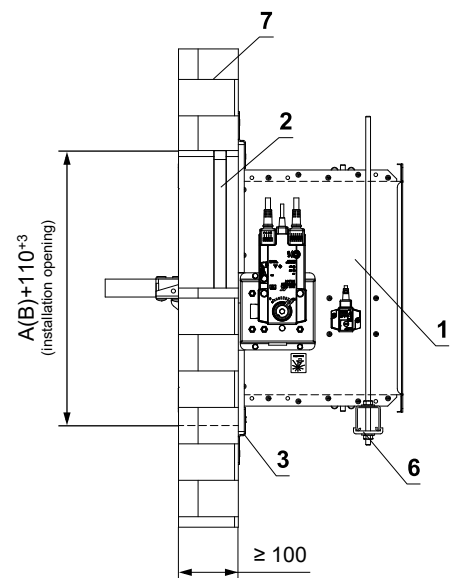
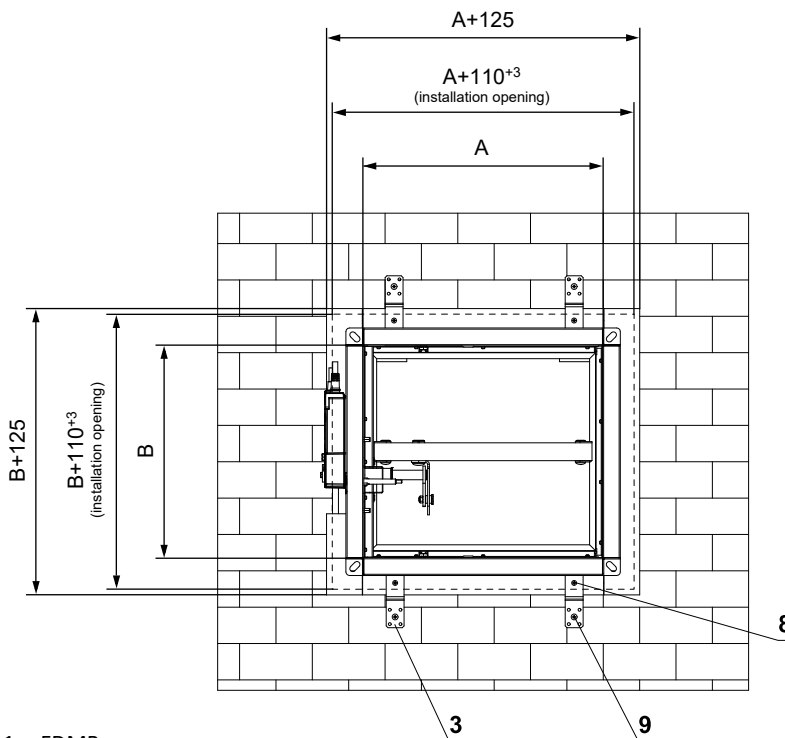
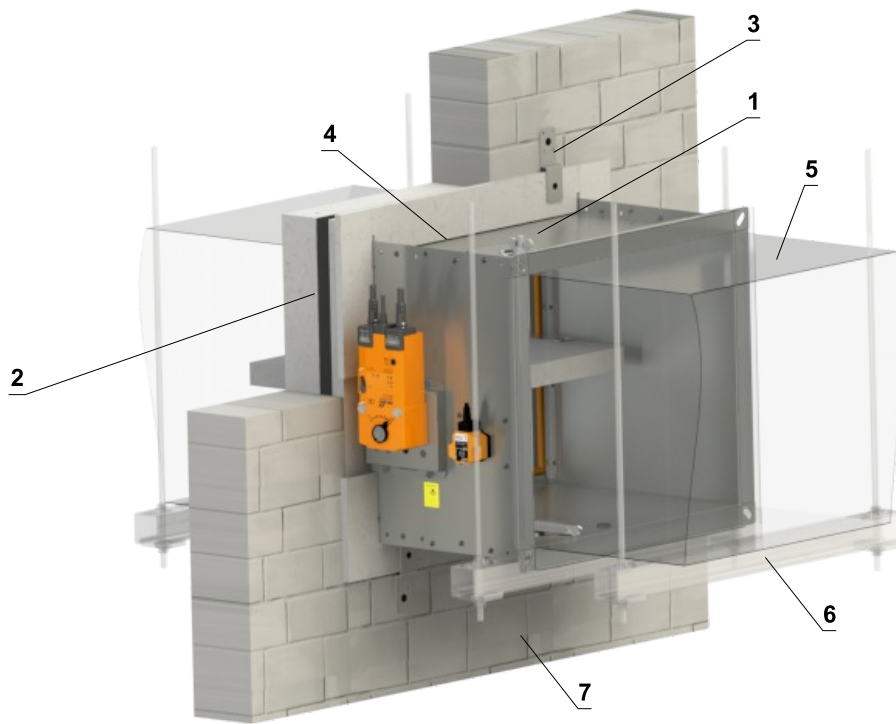

- 1 FDMB
- 2 Installation frame
- 3 Bracket (fastening material included in frame delivery)
- 4 Fill the gaps with glue PROMAT K84
- 5 Duct
- 6 Profile with threaded rod → see pages 73 to 76
- 7 Solid wall construction
- 8 Screw 4x16 mm to attach bracket to the frame
- 9 Screw 5x60 mm to attach bracket to the construction

Number of brackets $X = ZA + ZB$ Number of screws $Y = 2 \times X$

Side A	Number of brackets ZA	Side B	Number of brackets ZB
$A \leq 500$	4	$B \leq 500$	0
$500 < A \leq 1000$	6		

In gypsum wall construction - installation frame E1

EI 90 (ve) S [V/H]

- For connection of following duct → see page 77
- Installation frame can be installed on the damper or delivered separately
- The installation opening is lined with a UW/CW profile.

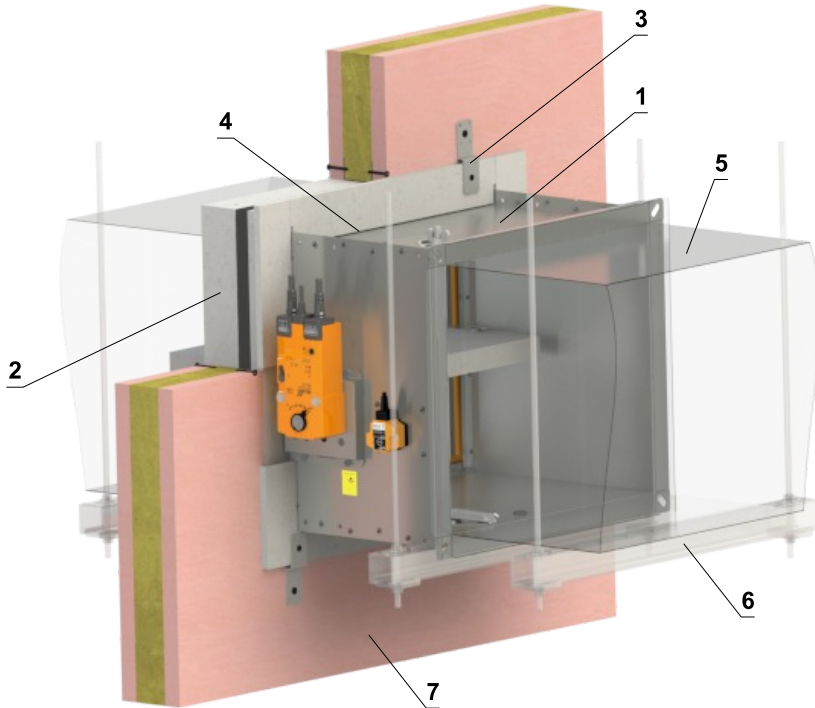

Detail of the wall > 100 mm

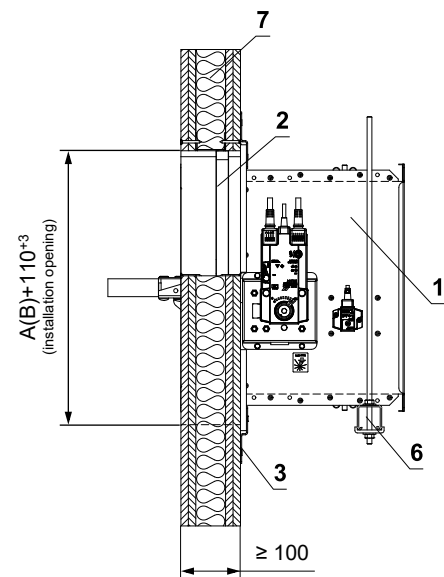
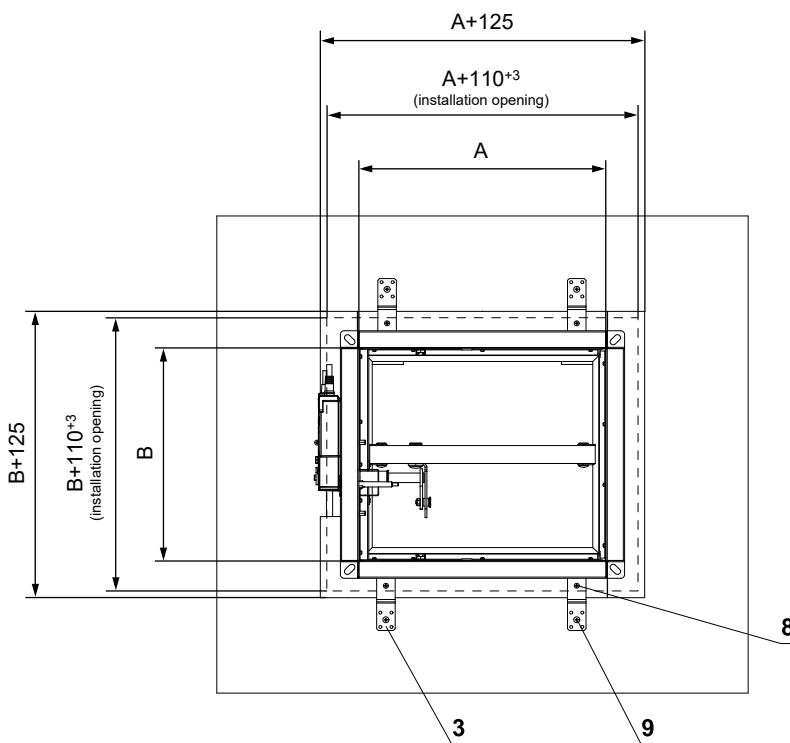
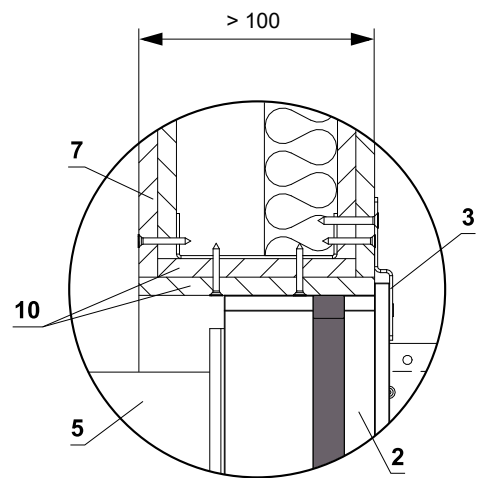

- 1 FDMB
- 2 Installation frame
- 3 Bracket (fastening material included in frame delivery)
- 4 Fill the gaps with glue PROMAT K84
- 5 Duct
- 6 Profile with threaded rod → see pages 73 to 76
- 7 Gypsum wall construction
- 8 Screw 4x16 mm to attach bracket to the frame
- 9 Screw 5x60 mm to attach bracket to the construction
- 10 Additional boards made from plasterboard

Number of brackets $X = ZA + ZB$ Number of screws $Y = 2 \times X$

Side A	Number of brackets ZA	Side B	Number of brackets ZB
$A \leq 500$	4	$B \leq 500$	0
$500 < A \leq 1000$	6		

Solid ceiling construction - installation frame E1

EI 90 (h_o) S [H]

- For connection of following duct → see page 77
- Installation frame can be installed on the damper or delivered separately
- The damper can be installed from both sides of the construction, i.e. From the top or the bottom side of the ceiling.

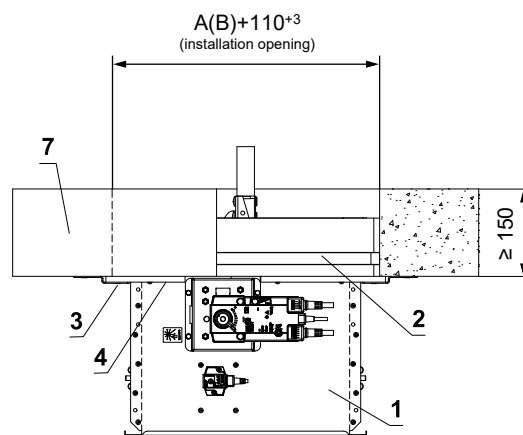
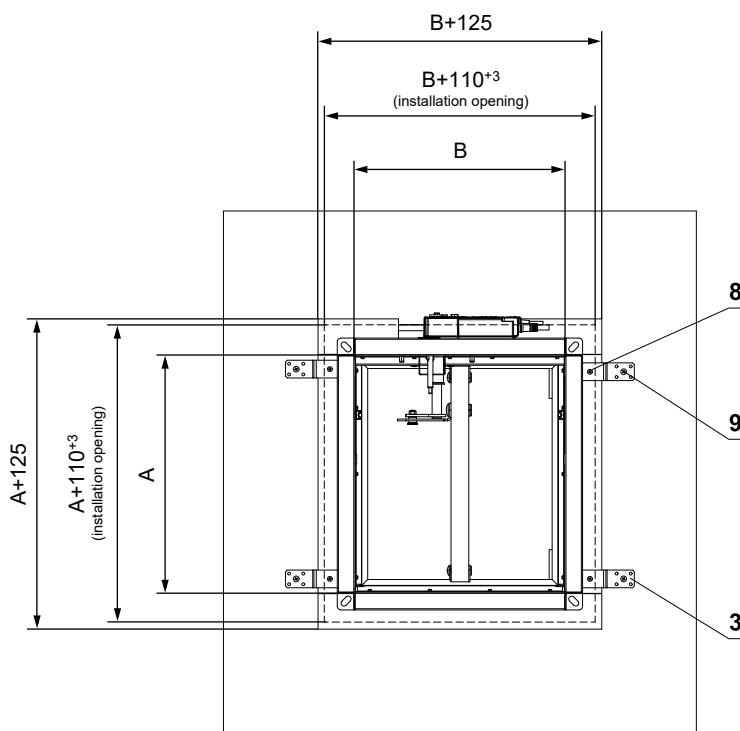
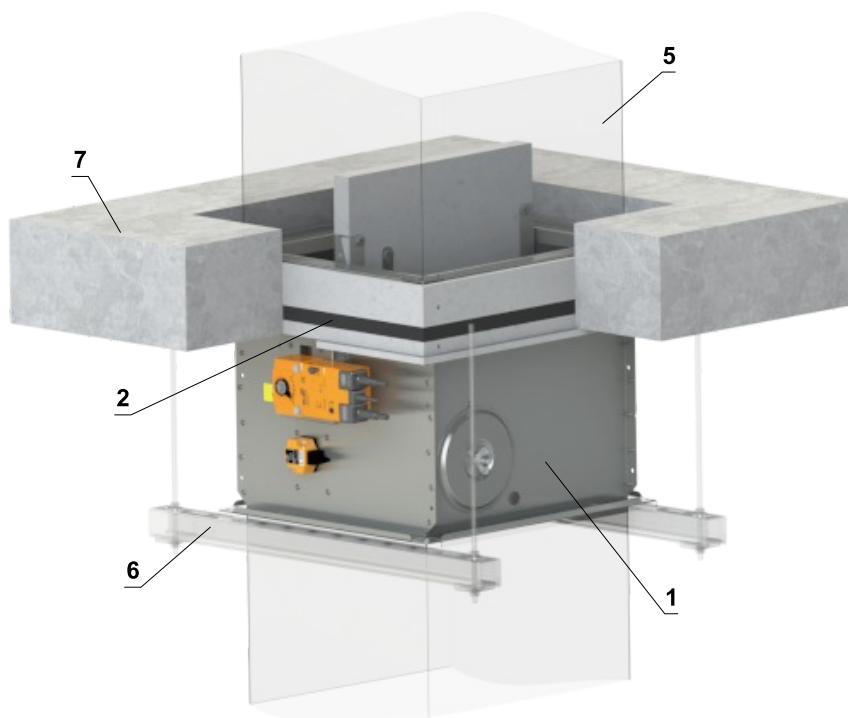

- 1 FDMB
- 2 Installation frame
- 3 Bracket (fastening material included in frame delivery)
- 4 Fill the gaps with glue PROMAT K84
- 5 Duct
- 6 Profile with threaded rod → see pages 73 to 76
- 7 Solid ceiling construction
- 8 Screw 4x16 mm to attach bracket to the frame
- 9 Screw 5x60 mm to attach bracket to the construction

Number of brackets X = ZA + ZB Number of screws Y = 2 x X

Side A	Number of brackets ZA	Side B	Number of brackets ZB
A ≤ 500	4	B ≤ 500	0
500 < A ≤ 1000	6		

Installation frame E2

- Installation frame E2 is designed for installation with steel insert and mortar or gypsum into:
 - Solid wall construction
 - Solid ceiling construction
- The damper is equipped with an intumescent sealing on the casing. This sealing fills the gap between the steel insert and the damper in the event of a fire
- **Solid wall th. 100 mm or solid ceiling th. 150 mm**
- Material:
 - Installation frame - galvanized steel
 - Fasteners - galvanized steel

Installation frame E2

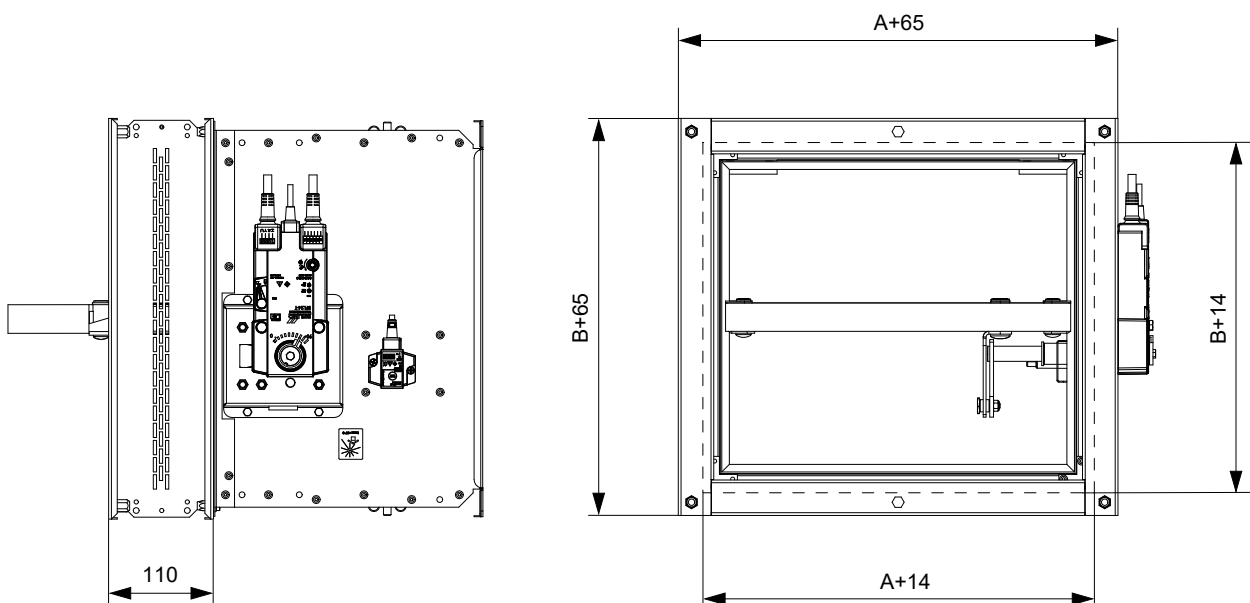
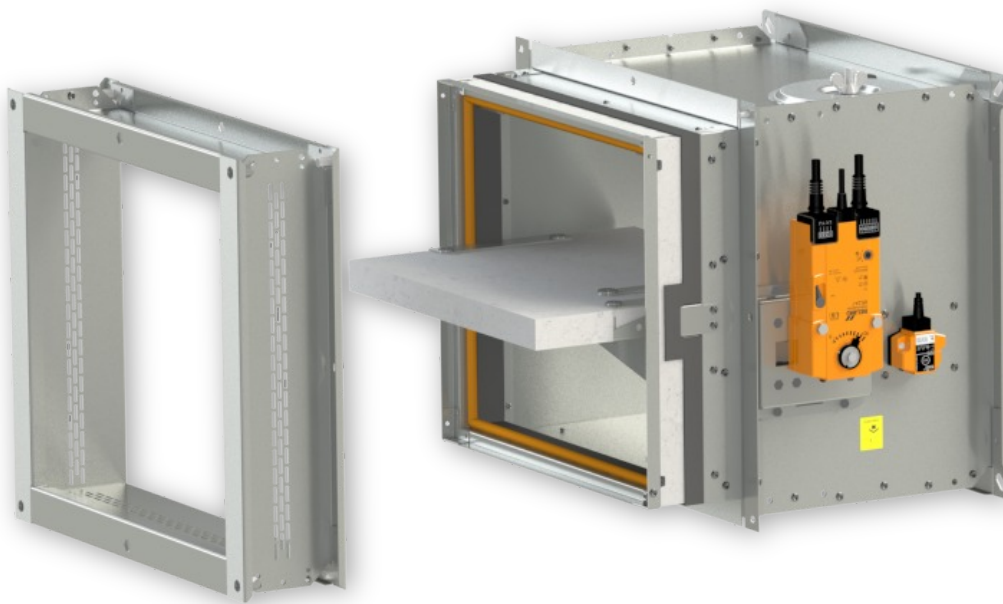

In solid wall construction - installation frame E2

EI 90 (v_e) S [V/H]

- For connection of following duct → see page 77
- The installation frame can only be delivered installed on the damper.

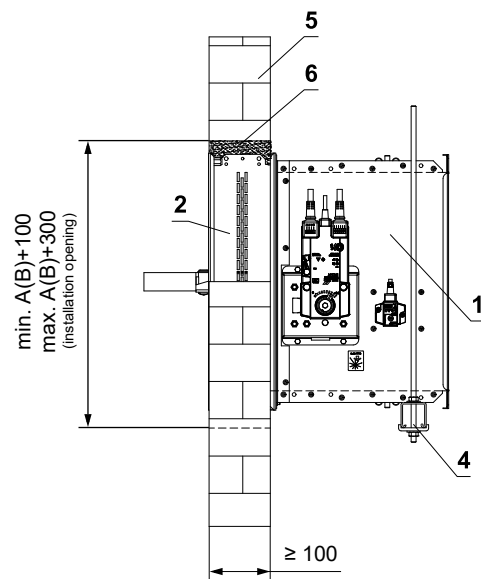
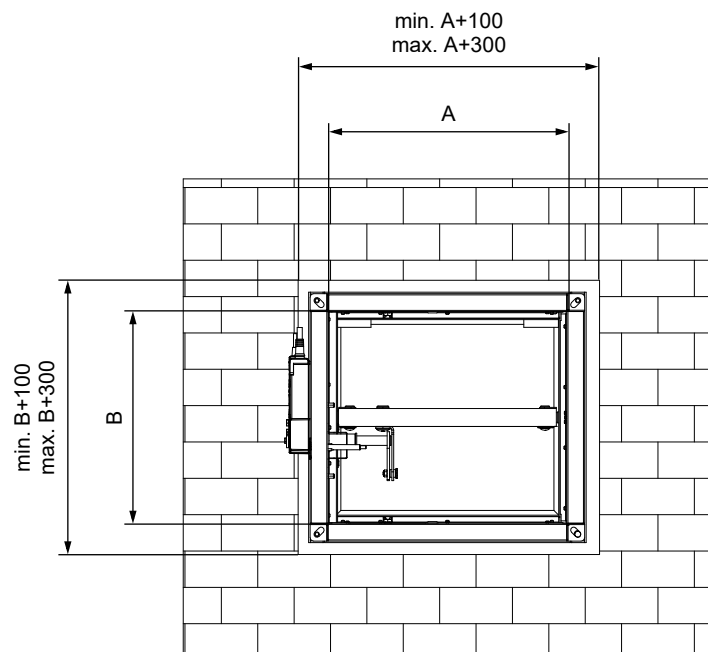
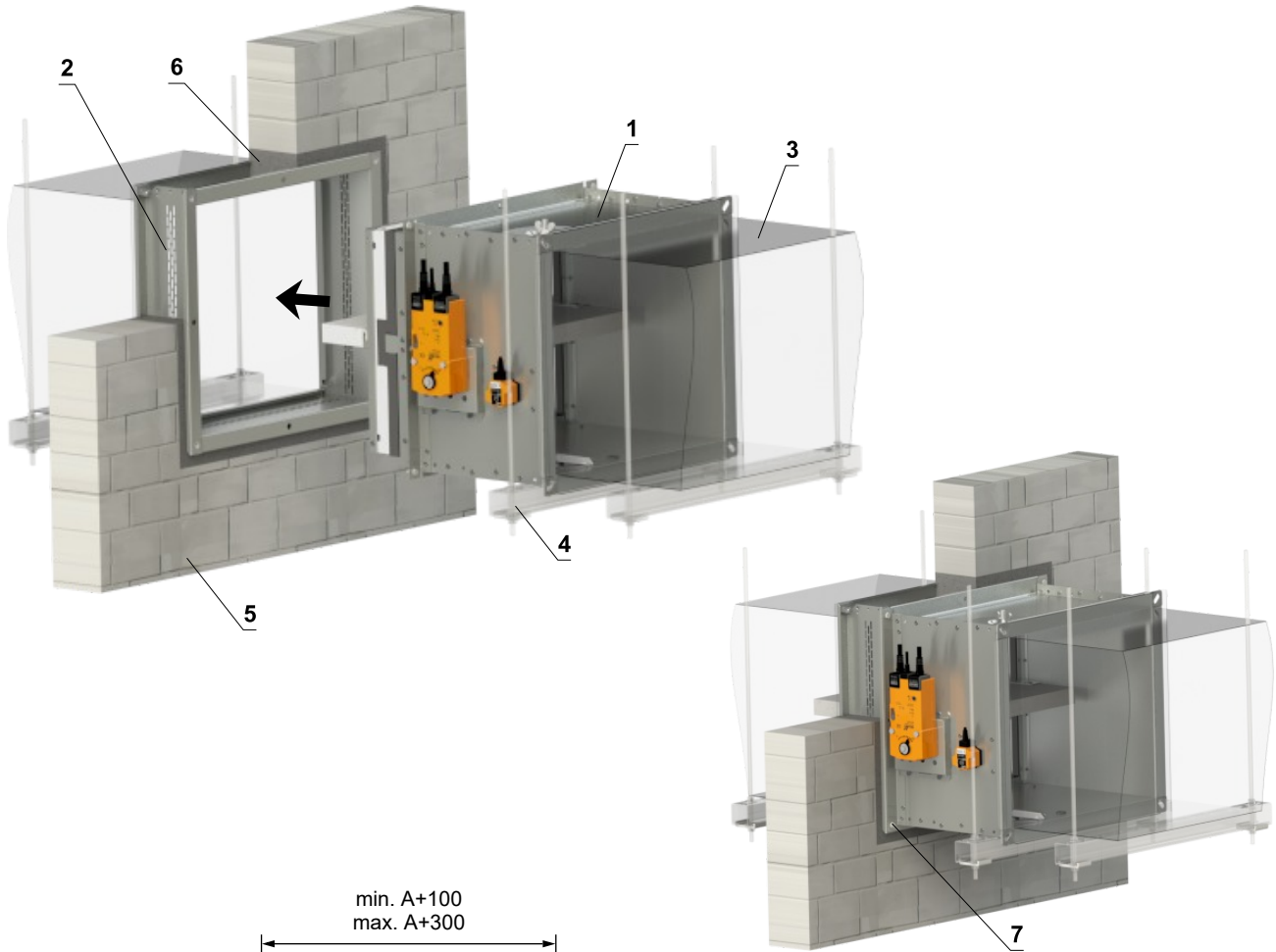

- 1 FDMB
- 2 Installation frame
- 3 Duct
- 4 Profile with threaded rod → see pages 73 to 76
- 5 Solid wall construction
- 6 Mortar or gypsum
- 7 Screw M6x12 (4x)

In solid ceiling construction - installation frame E2

EI 90 (h_o) S [H]

- For connection of following duct → see page 77
- The installation frame can only be delivered installed on the damper.
- The damper can be installed from both sides of the construction, i.e. From the top or the bottom side of the ceiling.

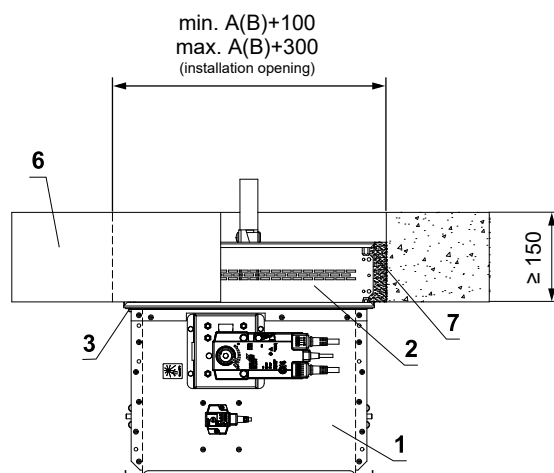
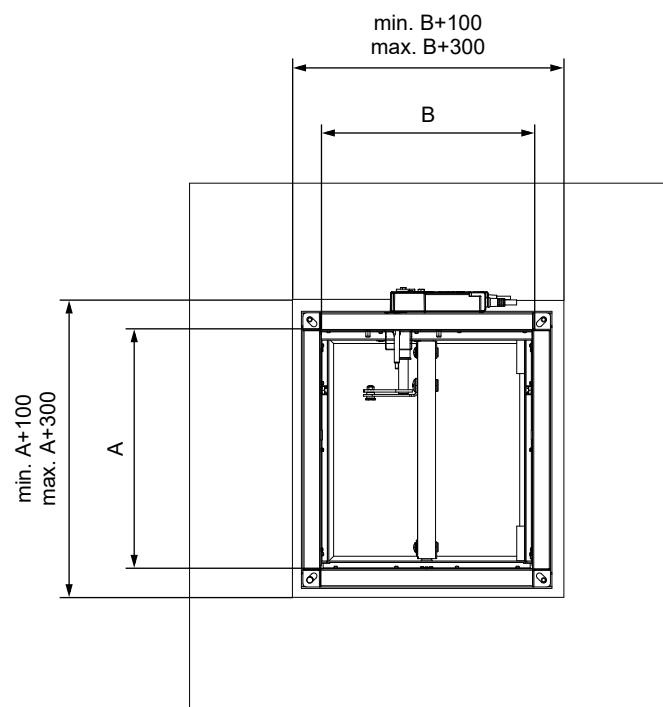
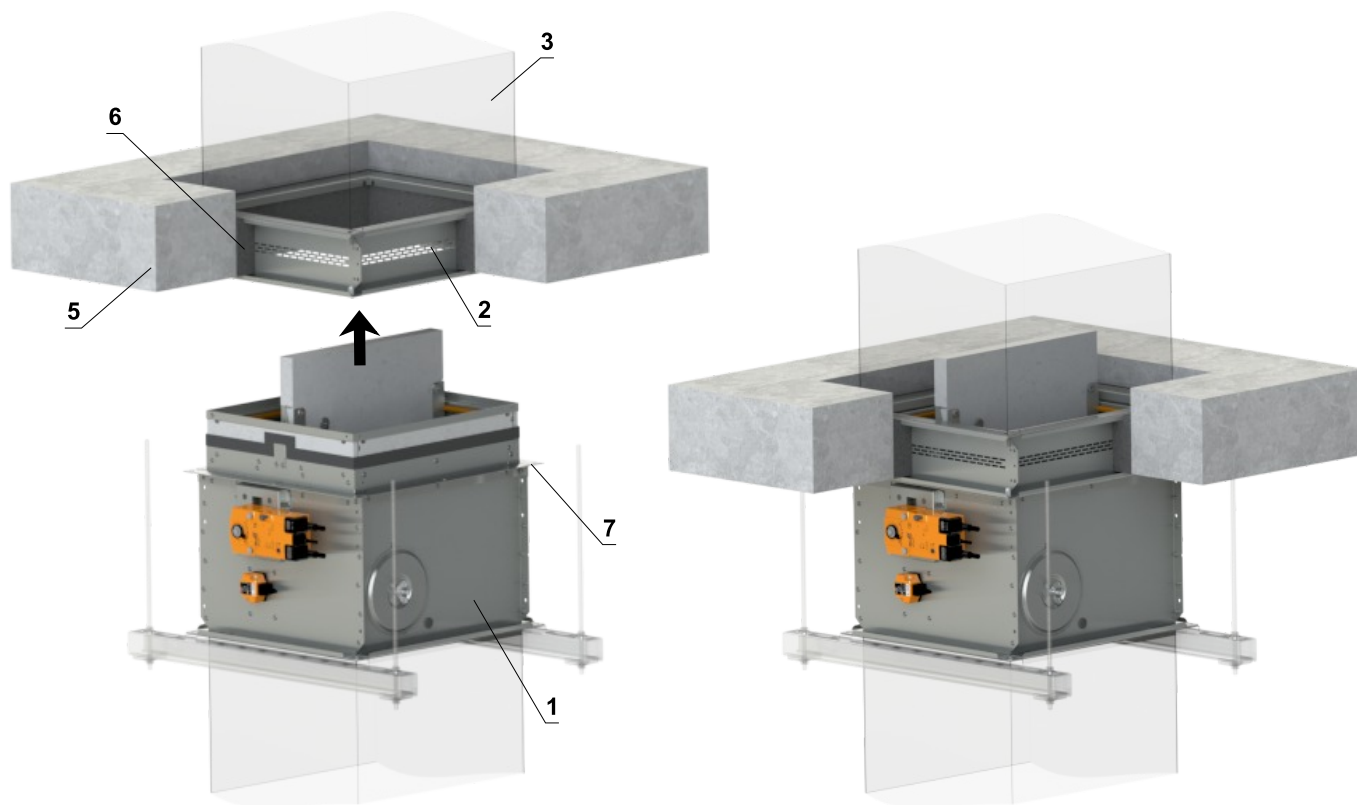

- 1 FDMB
- 2 Installation frame
- 3 Duct
- 4 Profile with threaded rod → see pages 73 to 76
- 5 Solid ceiling construction
- 6 Mortar or gypsum
- 7 Screw M6x12 (4x)

Installation frame E3

- Installation frame E2 is designed for installation into:
 - Gypsum wall construction
- The damper is equipped with an intumescent sealing on the casing. This sealing fills the gap between the damper casing and frame in the event of a fire. The frame is equipped with an intumescent sealing on external side. This sealing fills the gap between the frame and construction in the event of a fire
- **Gypsum wall th. 100 mm**
- Material:
 - Installation frame - cement-lime boards and galvanized steel
 - Fasteners - galvanized steel

Installation frame E3

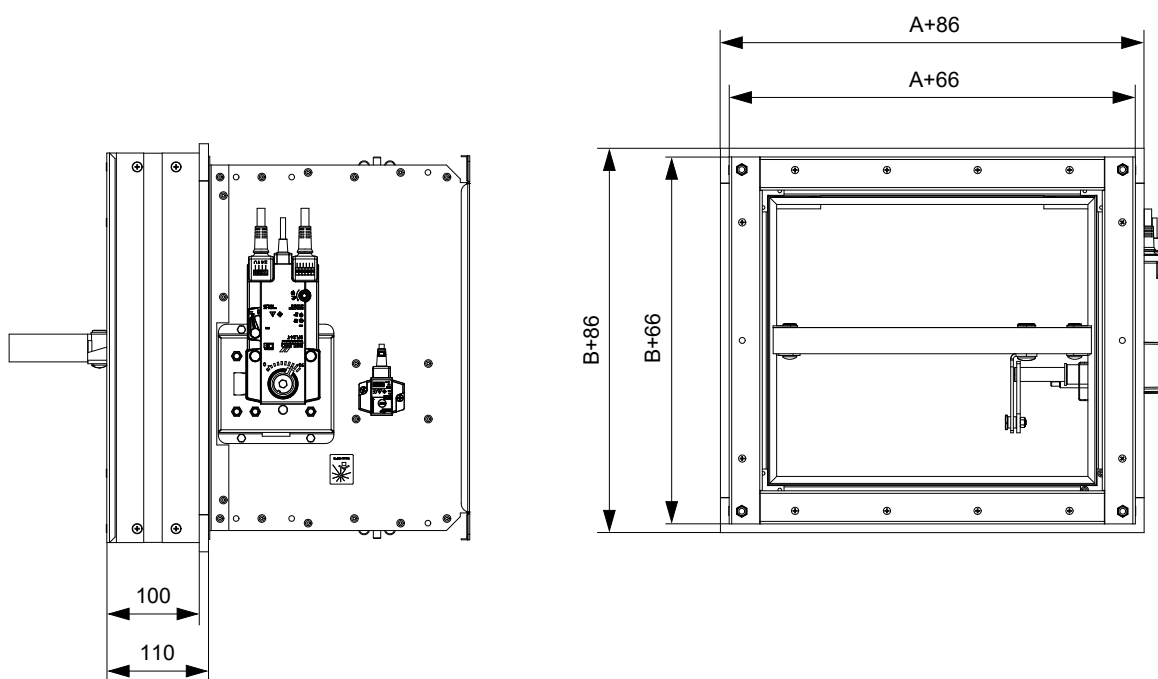
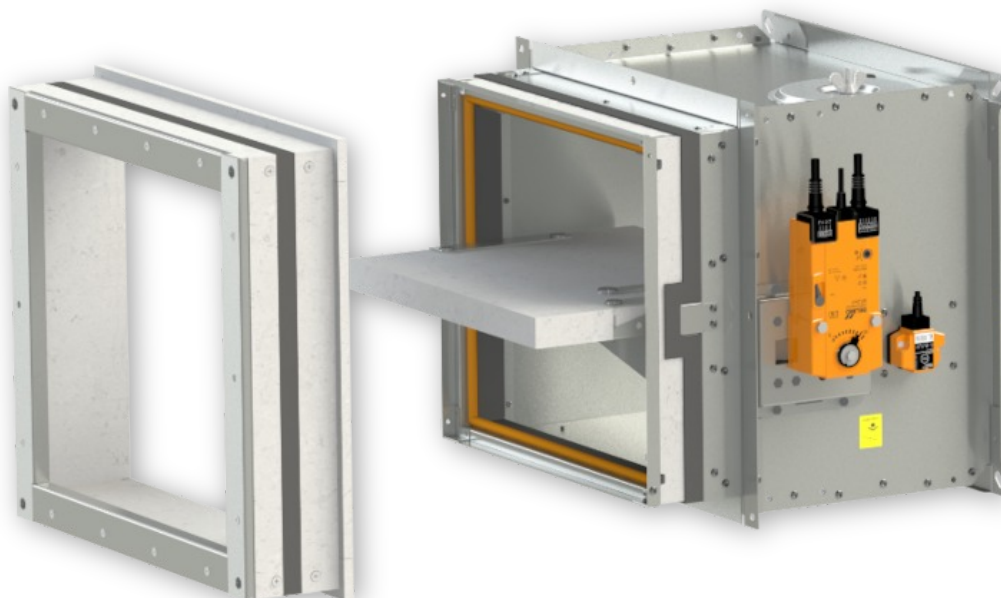

In gypsum wall construction - installation frame E3

EI 90 (ve) S [V/H]

- For connection of following duct → see page 77
- The installation frame can only be delivered installed on the damper.
- The installation opening is lined with a UW/CW profile.

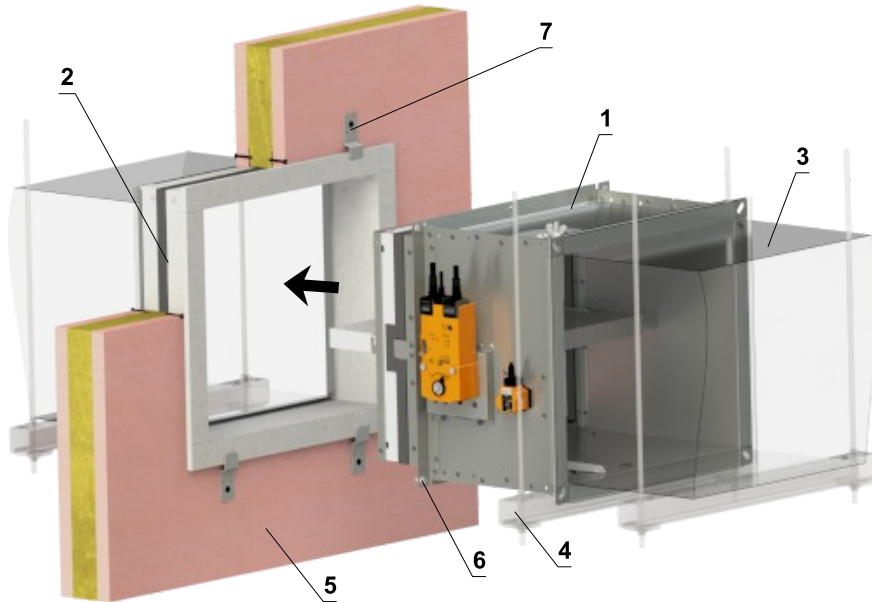
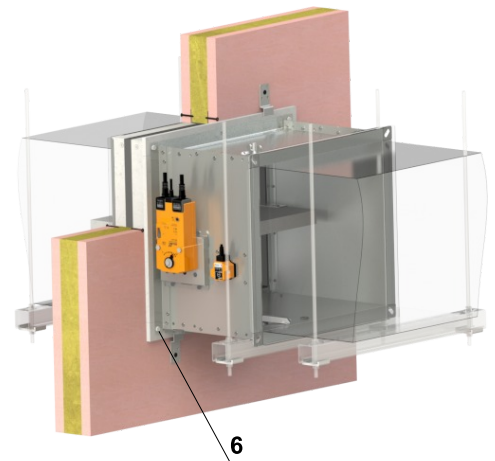

Detail of the wall > 100 mm

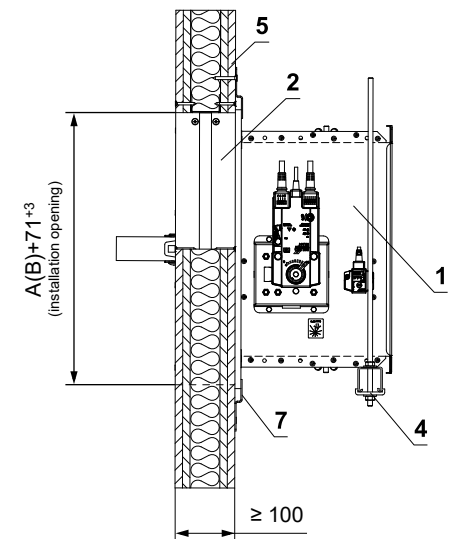
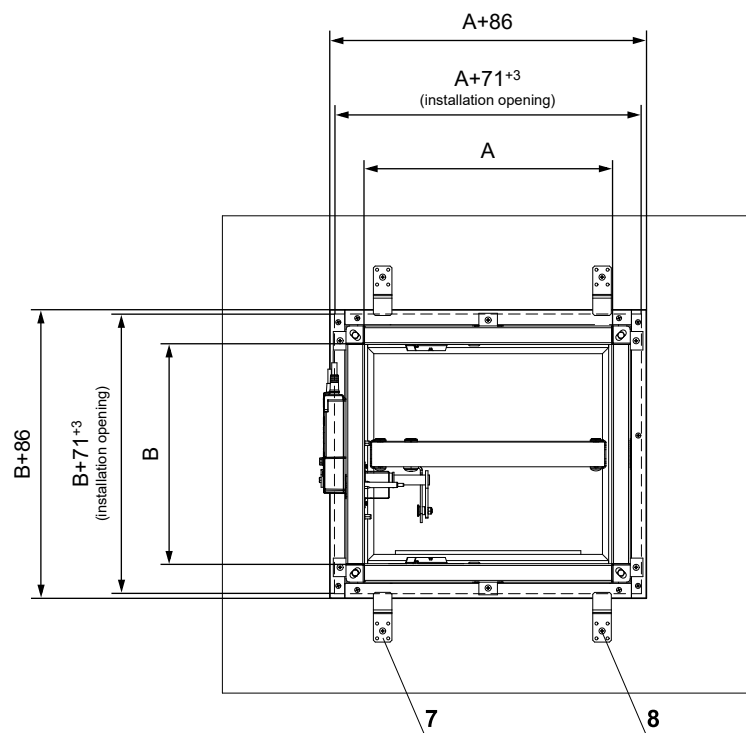
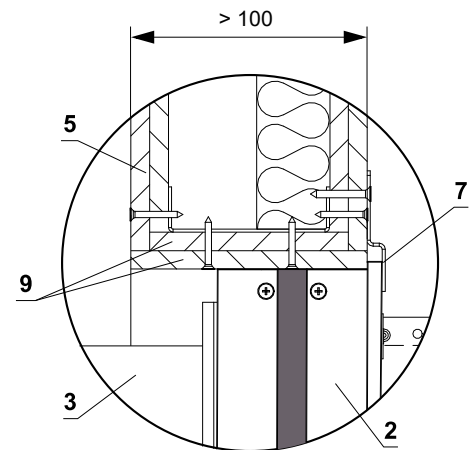

- 1 FDMB
- 2 Installation frame
- 3 Duct
- 4 Profile with threaded rod → see pages 73 to 76
- 5 Gypsum wall construction
- 6 Screw 6x12 mm (4x)
- 7 Bracket (fastening material included in frame delivery)
- 8 Screw 5x60 mm to attach bracket to the construction
- 9 Additional boards made from plasterboard

Number of brackets $X = ZA + ZB$ Number of screws $Y = 2 \times X$

Side A	Number of brackets ZA	Side B	Number of brackets ZB
$A \leq 500$	4	$B \leq 500$	0
$500 < A \leq 1000$	6		

Installation frame E4

- Installation frame E4 is designed for installation on:
 - Solid wall construction
 - Solid ceiling construction
 - Outside solid ceiling construction with concreting
- Installation frame is equipped with an intumescent sealing on the inside. This sealing fills the gap between the damper casing and frame in the event of a fire
- Material:
 - Installation frame - cement-lime boards
 - Fasteners - galvanized steel

Installation frame E4

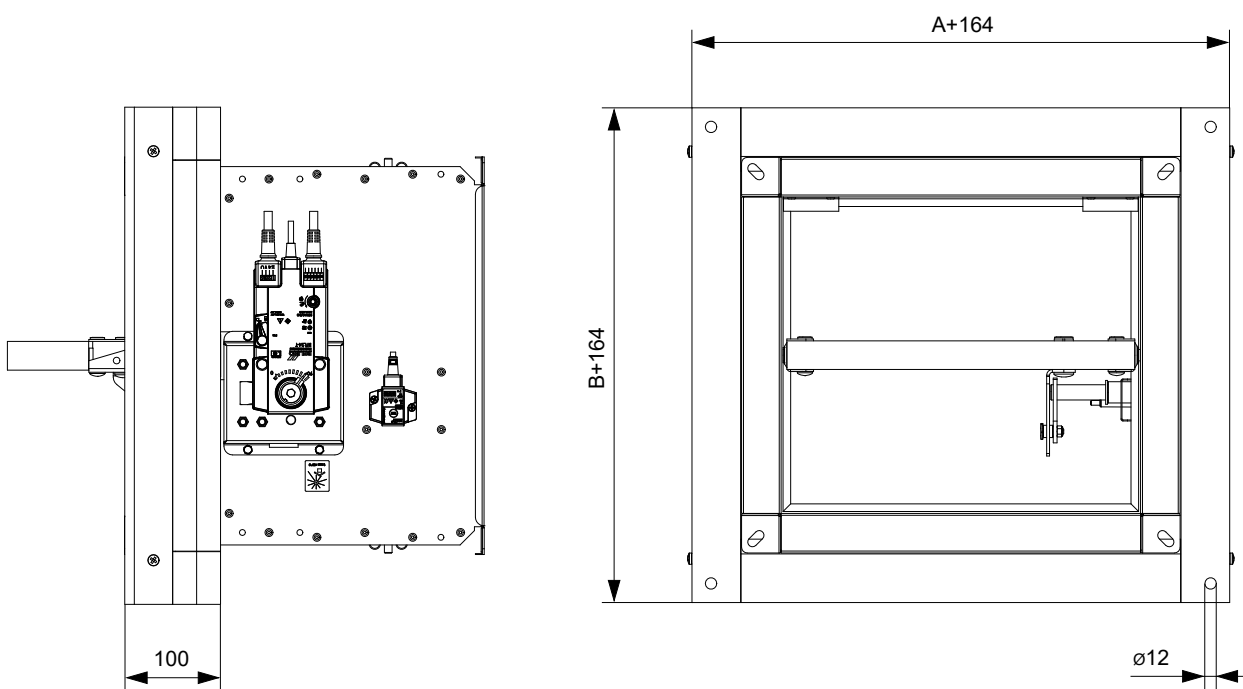

In solid wall construction - installation frame E4

EI 90 (v_e) S [V/H]

- For connection of following duct → see page 77
- Installation frame can be installed on the damper or delivered separately

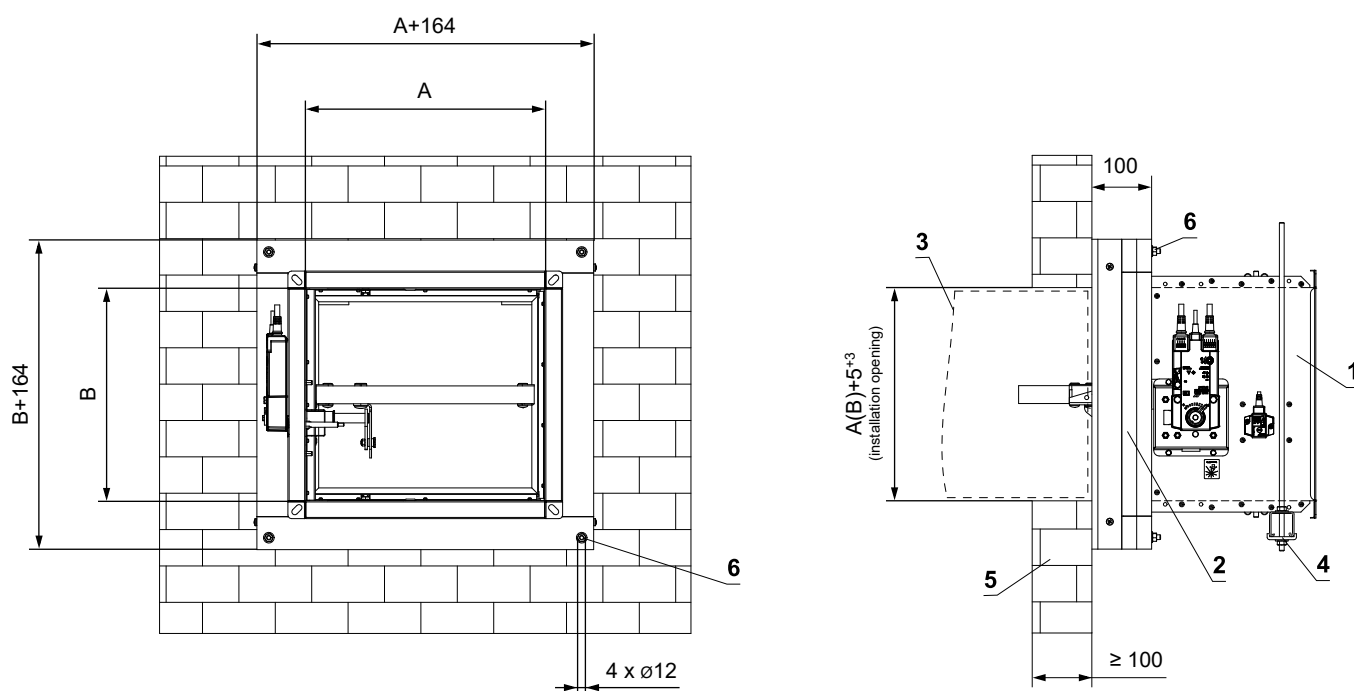
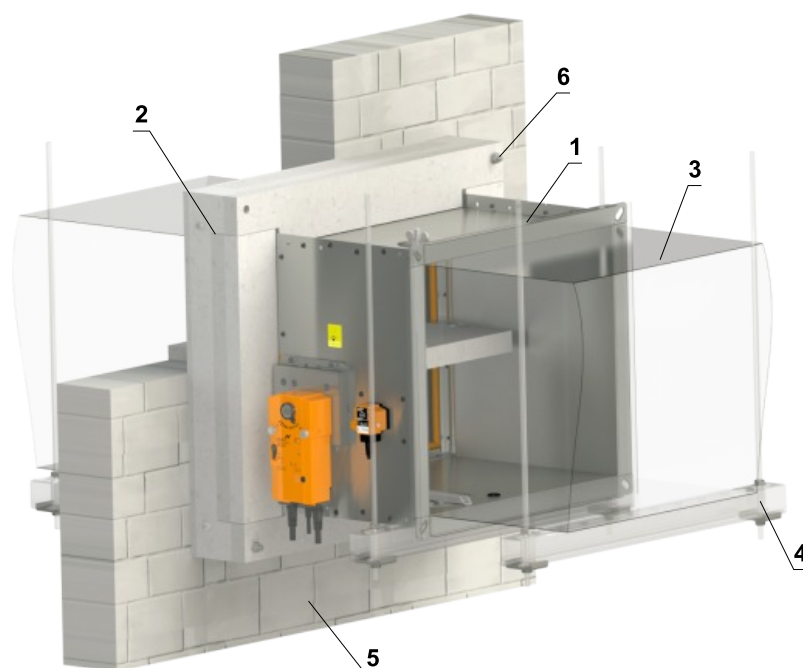

- 1 FDMB
- 2 Installation frame - apply HILTI CFS-S ACR mastic at the entire area and glue it to the fire separating construction
- 3 Duct
- 4 Profile with threaded rod → see pages 73 to 76
- 5 Solid wall construction
- 6 Holes for fixing the frame with threaded rods or steel anchors (material for fixing the frame is not included)

In solid ceiling construction - installation frame E4

EI 90 (h_o) S [H]

- For connection of following duct → see page 77
- Installation frame can be installed on the damper or delivered separately
- The damper can be installed from both sides of the construction, i.e. From the top or the bottom side of the ceiling.

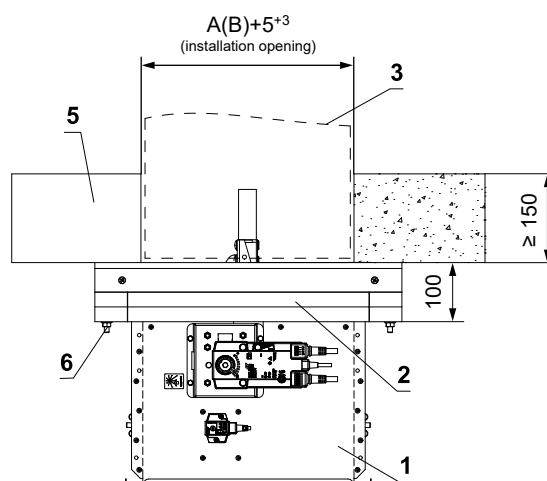
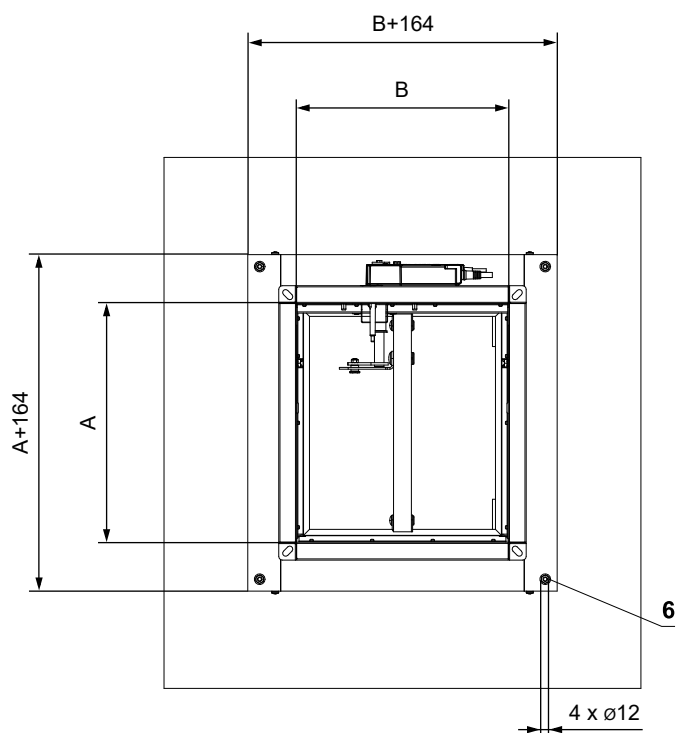
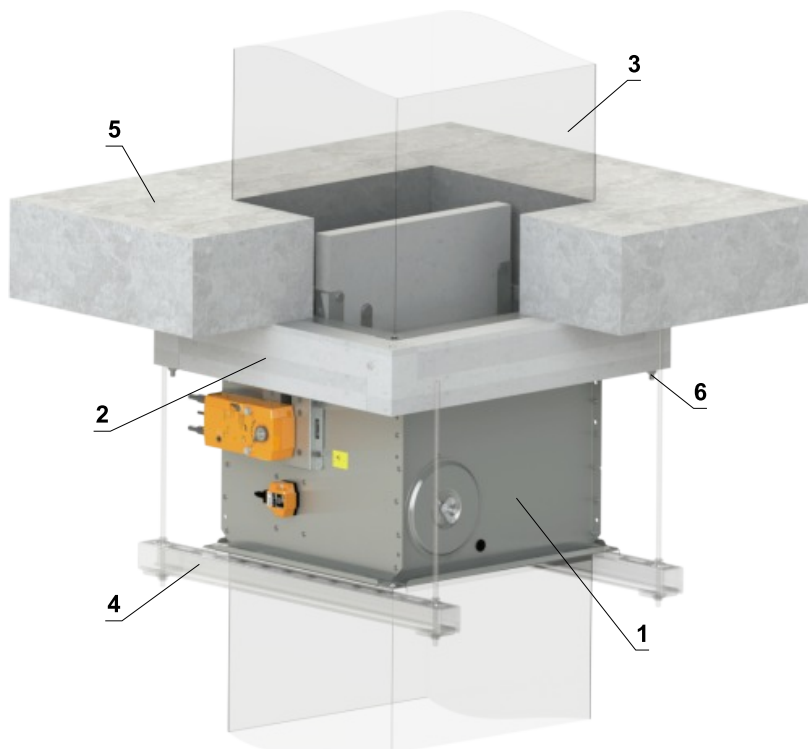

- 1 FDMB
- 2 Installation frame - apply HILTI CFS-S ACR mastic at the entire area and glue it to the fire separating construction
- 3 Duct
- 4 Profile with threaded rod → see pages 73 to 76
- 5 Solid ceiling construction
- 6 Holes for fixing the frame with threaded rods or steel anchors (material for fixing the frame is not included)

Installation frame E5

- Installation frame E5 is designed for installation without additional sealing of the penetration for:
 - Installation in gypsum walls under flexible ceilings with a maximum movement of 40 mm
 - **Wall thicknesses of 100 or ≥ 115 mm**
- Installation frame is equipped with an intumescent sealing on the inside and outside. This sealing fills the gap between the damper casing and frame and between the frame and construction in the event of a fire
- Position of the damper can be directly on the ceiling or at a distance of max. 80 mm from the ceiling
- Material:
 - Installation frame - cement-lime boards and galvanized steel
 - Fasteners - galvanized steel

Installation frame E5

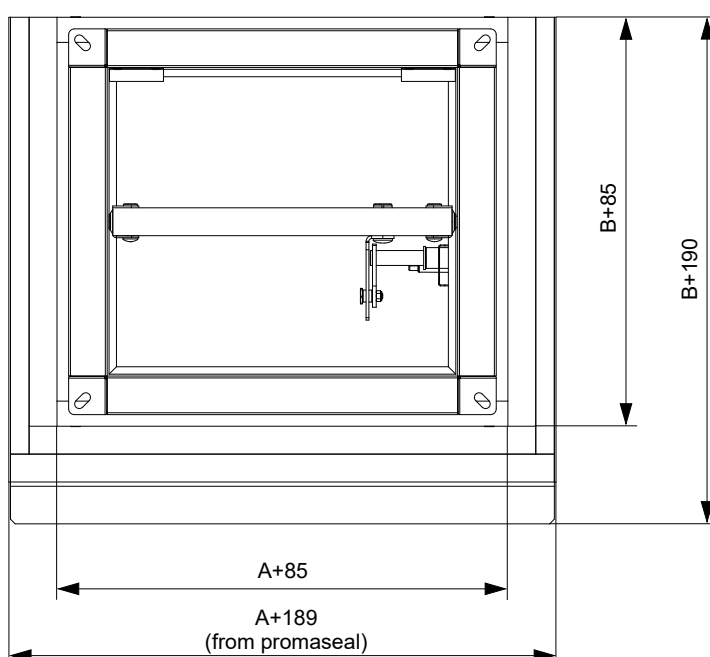
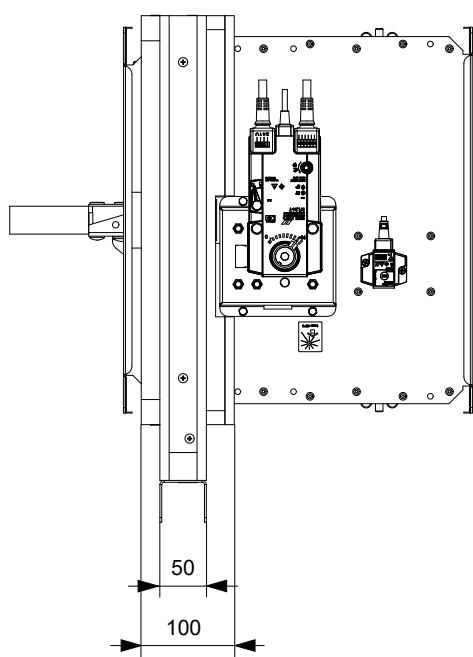
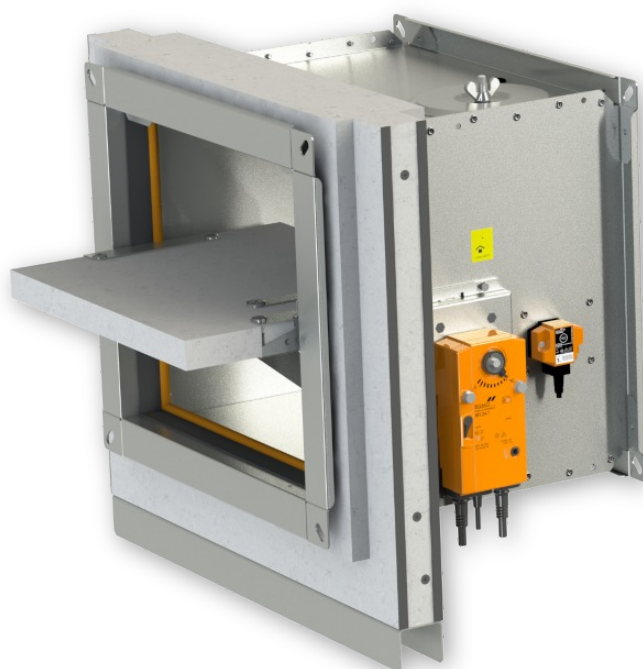

In gypsum wall construction - flexible ceiling - installation frame E5

Installation directly on the ceiling

EI 90 (v_e) S [V/H]

- Detailed instructions for installation E5 frame → see manual
- For connection of following duct → see page 77
- Installation frame can be installed on the damper or delivered separately
- Gypsum construction must be made in accordance with the specifications of the wall system manufacturer

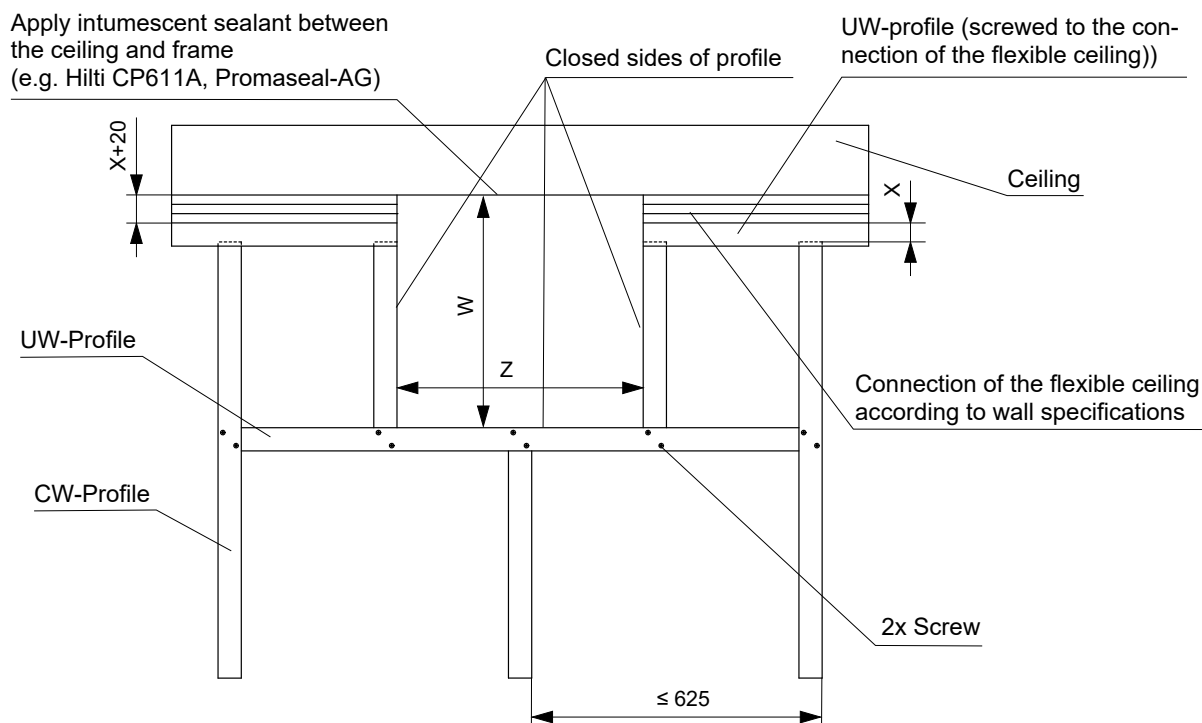
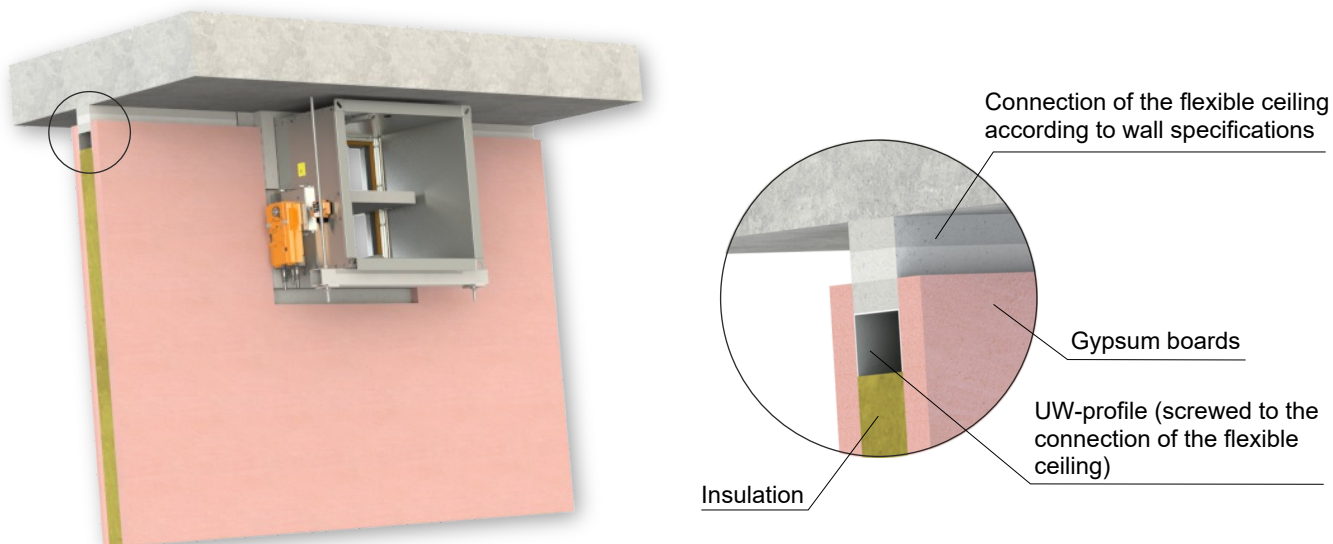

Installation frame	W [mm]	Z [mm]
E5	$B + 190 + X$	$A + 189 + (2 \times F)$

- X = ceiling movement ≤ 40 mm
- F = gap between frame (promaseal) and profile = 2 to 5 mm

Installation at a maximum distance of 80 mm from the ceiling

EI 90 (v_e) S [V/H]

- Detailed instructions for installation E5 frame → see manual
- For connection of following duct → see page 77
- Installation frame can be installed on the damper or delivered separately
- Gypsum construction must be made in accordance with the specifications of the wall system manufacturer

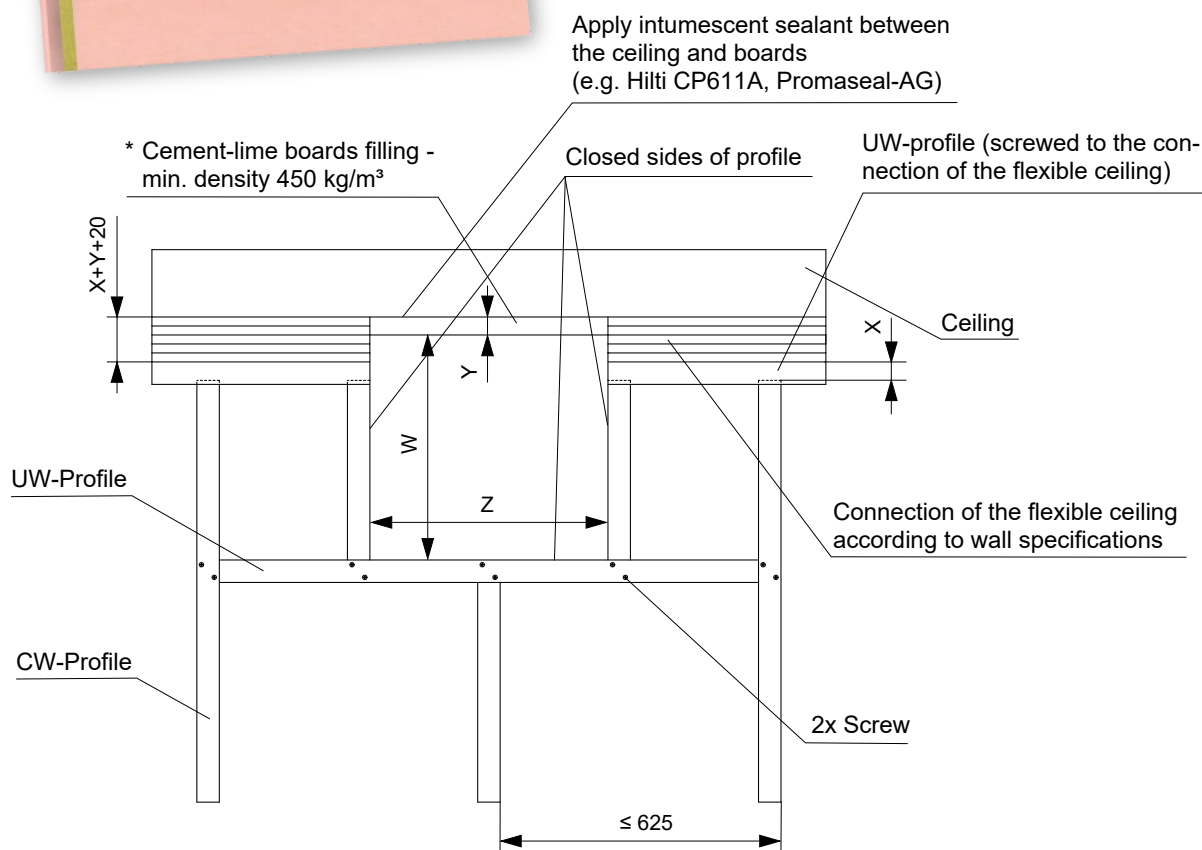
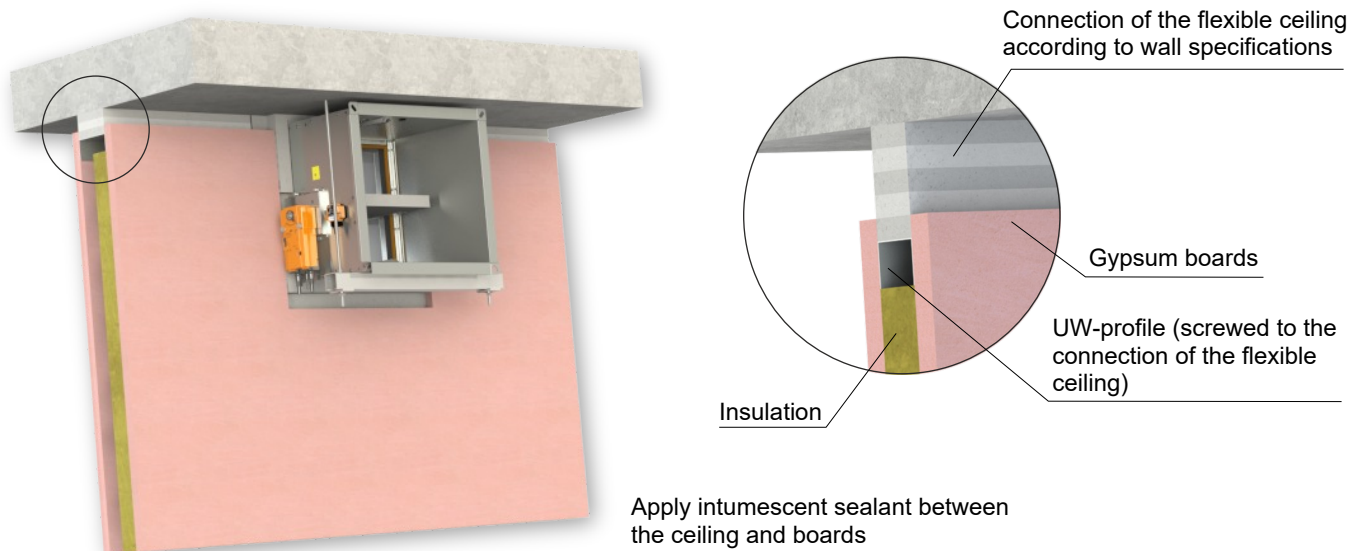

Installation frame	W [mm]	Z [mm]
E5	$B + 190 + X + Y$	$A + 189 + (2 \times F)$

* Width of the boards for frame E5 = 100 mm

- X = ceiling movement ≤ 40 mm
- Y = distance of frame from ceiling max. 80 mm
- F = gap between frame (promaseal) and profile = 2 to 5 mm

Installation frame E6

- Installation frame E6 is designed for installation without additional sealing of the penetration into:
 - Installation outside solid wall/ceiling construction with insulation from fire-resistant boards
- Installation frame is equipped with an intumescent sealing on the inside. This sealing fills the gap between the damper casing and frame in the event of a fire
- Material:
 - Installation frame - cement-lime boards
 - Fasteners - galvanized steel

Installation frame E6

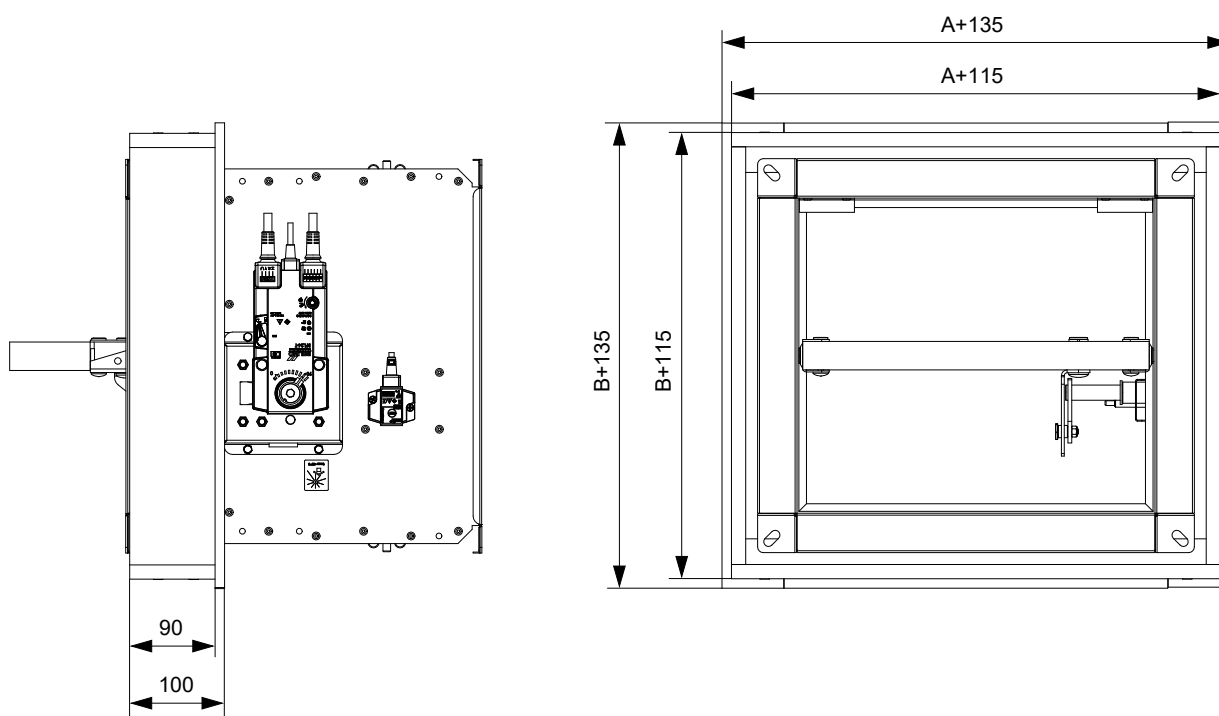

Outside solid wall construction - insulation from fire-resistant boards - mortar or gypsum - installation frame E6

EI 90 (ve) S [V/H]

- For connection of following duct → see page 77
- Minimum and maximum distance between the wall and fire damper is unlimited
- Insulation must be suspended using threaded rods and mounting profiles or other mounting system, according to national standards
- Duct inside the insulation must be suitably supported. The insulation must be suspended at the point of the duct support using threaded rods and mounting profiles
- Load of the suspension system depends on weight of the fire damper, duct system and the insulation → see page 73
- Max. distance between two suspension systems is 1500 mm
- Following air-conditioning duct must be suspended or supported so that all load transfer from the following duct to the fire damper is absolutely excluded
- Adjacent duct must be suspended or supported, as required by the duct suppliers
- Installation frame can be installed on the damper or delivered separately

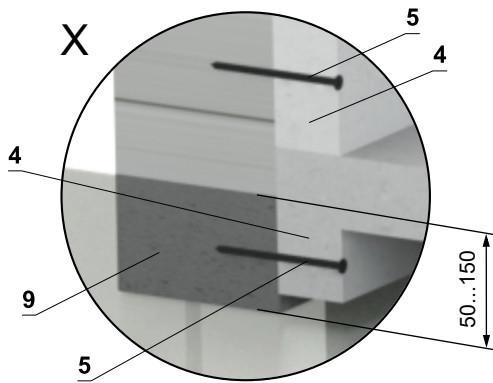

Additional board of duct

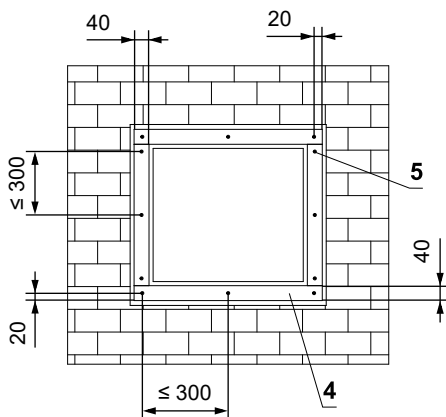

Additional board of frame

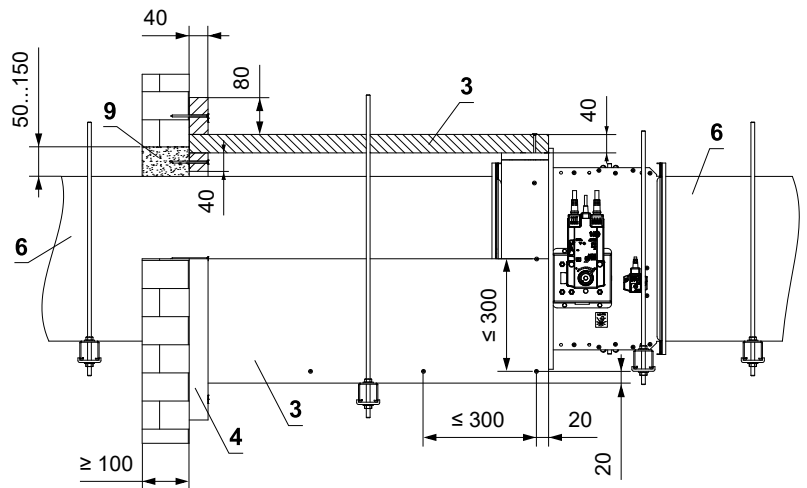
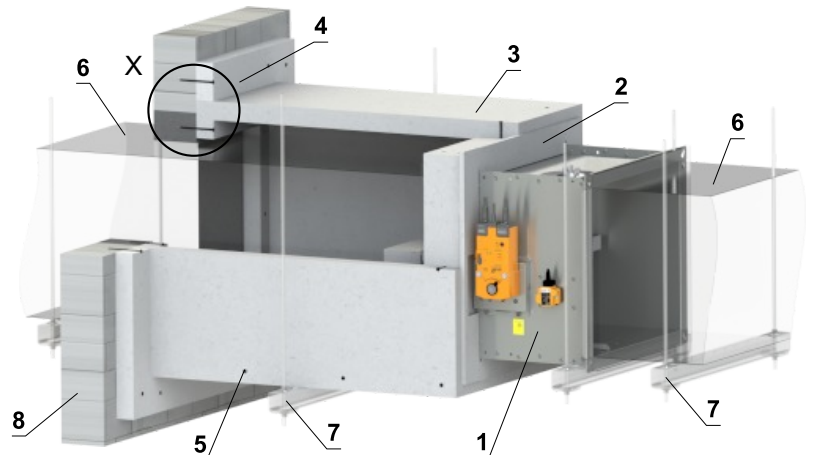
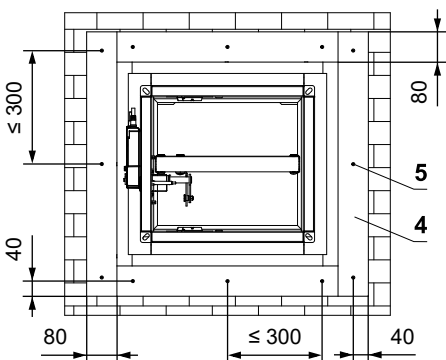

- | | |
|--|---|
| <p>1 FDMB</p> <p>2 Installation frame</p> <p>3 Insulation made of cement-lime board - min. thickness 40 mm, min. density 450 kg/m³ (e.g. PROMATECT-L). All parts are glued with glue Promat K84 and secured with screws 4x80 mm</p> <p>4 Additional board made of cement-lime board - min. thickness 40 mm, min. density 450 kg/m³ (e.g. PROMATECT-L). Apply HILTI CFS-S ACR mastic at the entire area and secure it with screws 4x80 mm</p> | <p>5 Screw 4x80 mm - screws must be firmly fixed in the wall construction, if necessary use steel anchors</p> <p>6 Standard air duct, made of galvanized sheet metal, thickness according to damper size</p> <p>7 Clamp with threaded rod → see pages 73 to 76</p> <p>8 Solid wall construction</p> <p>9 Mortar or gypsum</p> |
|--|---|

V. SUSPENSION SYSTEMS

Mounting to the ceiling wall

- The dampers must be suspended using threaded rods and mounting profiles. Their dimensioning depend on the weight of the damper.
- The dampers and the duct must be suspended separately.
- Following air-conditioning duct must be suspended or supported so that all load transfer from the following duct to the damper flanges is absolutely excluded. Adjacent duct must be suspended or supported, as required by the duct suppliers.
- Threaded rods longer than 1,5 m must be protected by fire insulation.

Examples of anchoring to the ceiling construction Follow the instructions of fixing specialist or installation company

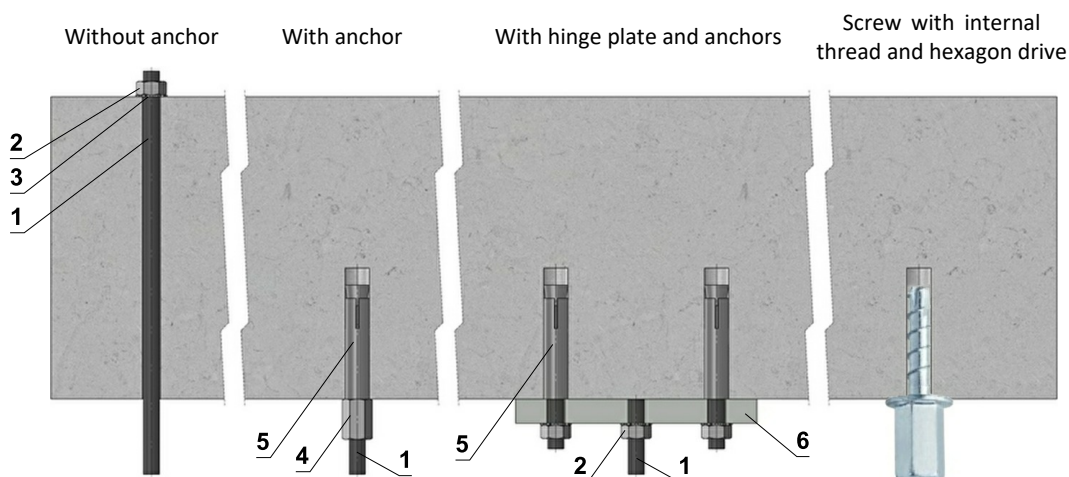

Hinge plates

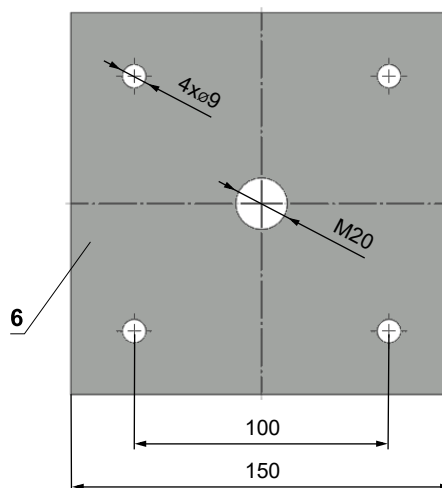
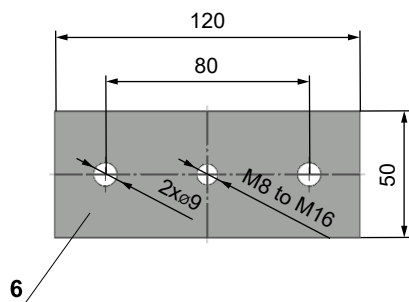

- If in doubt, always consult an anchor specialist engineer such as Halfen or Hilti.

Load capacities of threaded rods at the required fire resistance 60 min. $t \le 120 \text{ min.}$

Size	As [mm ²]	Weight [kg]	
		for 1 rod	for 2 rods
M8	36,6	22	44
M10	58	35	70
M12	84,3	52	104
M16	157	96	192
M18	192	117	234
M20	245	150	300

- 1 Threaded rod M8 - M20
- 2 Nut M8 - M20
- 3 Washer for M8 - M20
- 4 Coupling Nut M8 - M20
- 5 Anchor
- 6 Hinge plate - min. thickness 10 mm
- 7 Concrete screw tested for fire resistance R30-R90, max. Tension up to 0.75 KN (length 35 mm)

Example of placing of mounting profiles HILTI

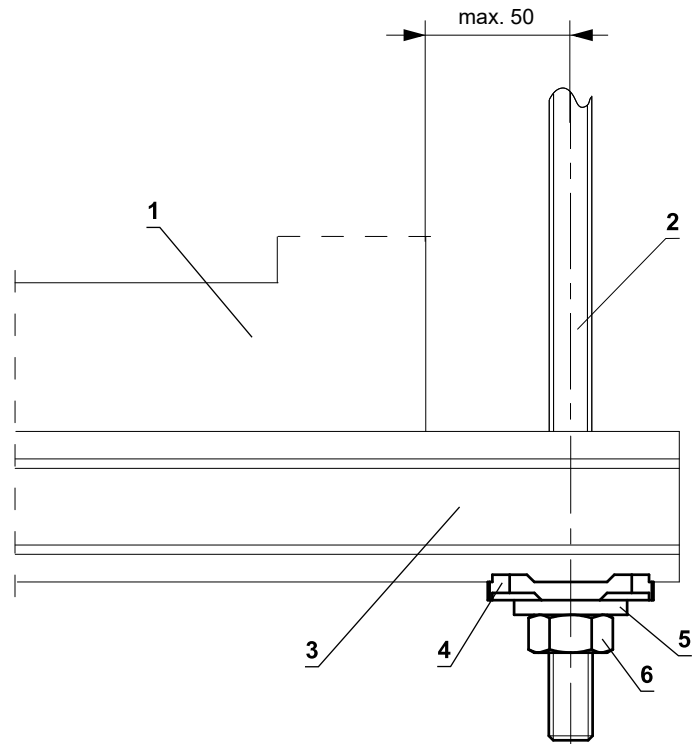
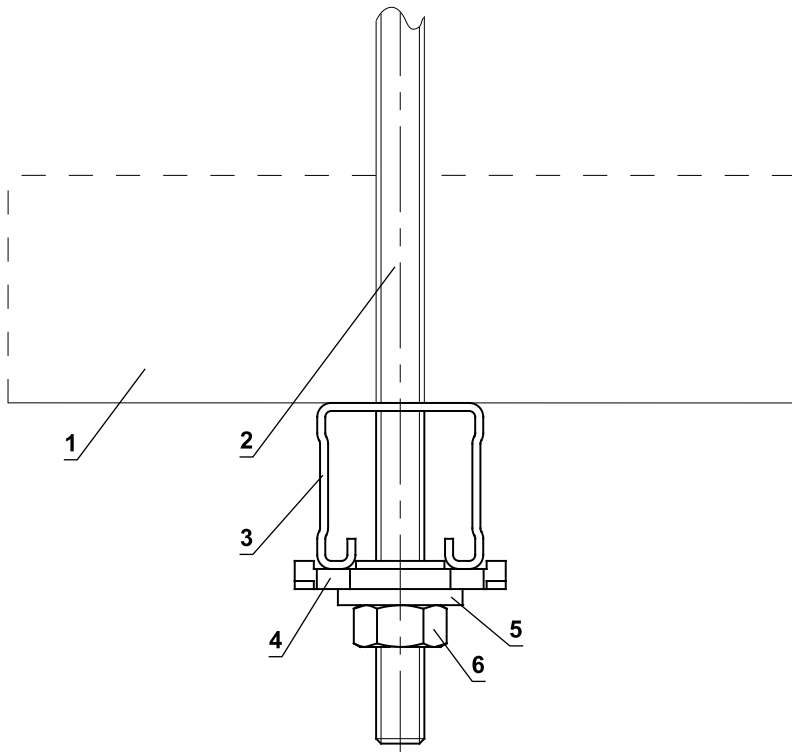

- 1 FDMB
- 2 Threaded rod M8 - M12
- 3 Support HILTI MQ-41 or MQ-41/3
- 4 Bored plate HILTI MQZ-L
- 5 Washer for M8 - M12
- 6 Nut M8 - M12

Example of fixing FDMB to the wall ceiling

In solid wall construction

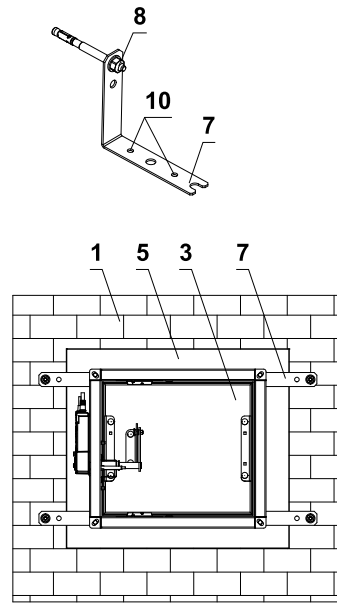
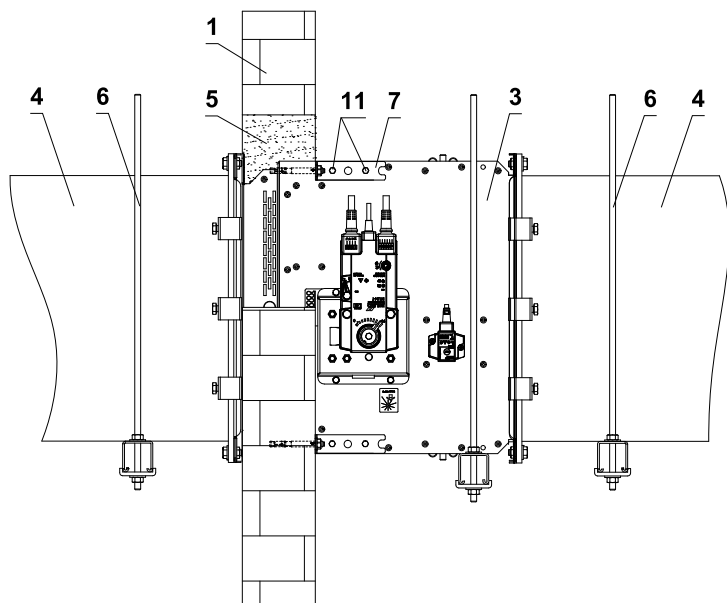

In gypsum wall construction

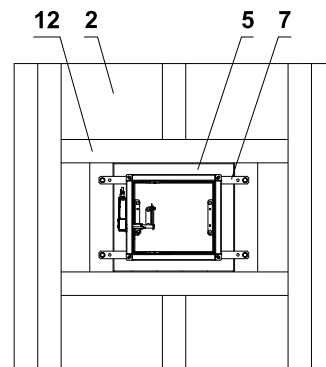
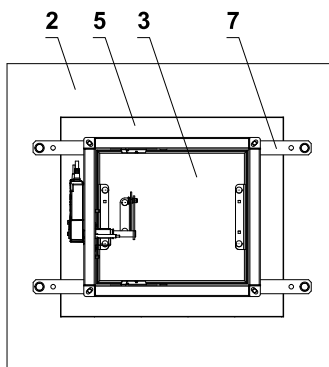
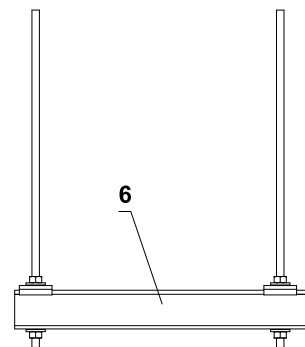
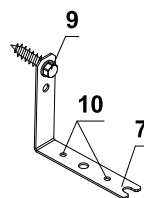
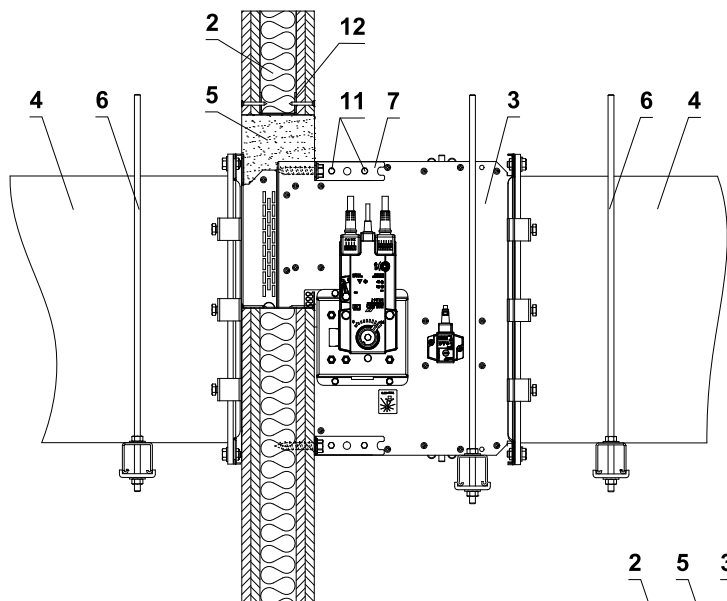

Grid from "U" profile

- 1 Solid wall construction
- 2 Gypsum wall construction
- 3 FDMB
- 4 Duct
- 5 Penetration
- 6 Profile with threaded rod → see page 74
- 7 Fixing element/steel bracket for fixing the damper to the wall (optional accessories from MANDÍK, a.s. or sheet metal min. thickness 2 mm and min. width 25 mm)
- 8 Nut M8 with anchor
- 9 Hexagon head screw
- 10 Installation holes
- 11 Screw assembly M6 (screw M6x10, nut M6)
- 12 Gypsum grid from "U" profile

■ The method of attachment must follow the minimum requirements for attachment and connection of ductwork in accordance with national regulations. Also, the elements can be suspended from the top, or supported from bottom, or fastened from the side.

Example of fixing FDMB to the ceiling

In solid ceiling construction

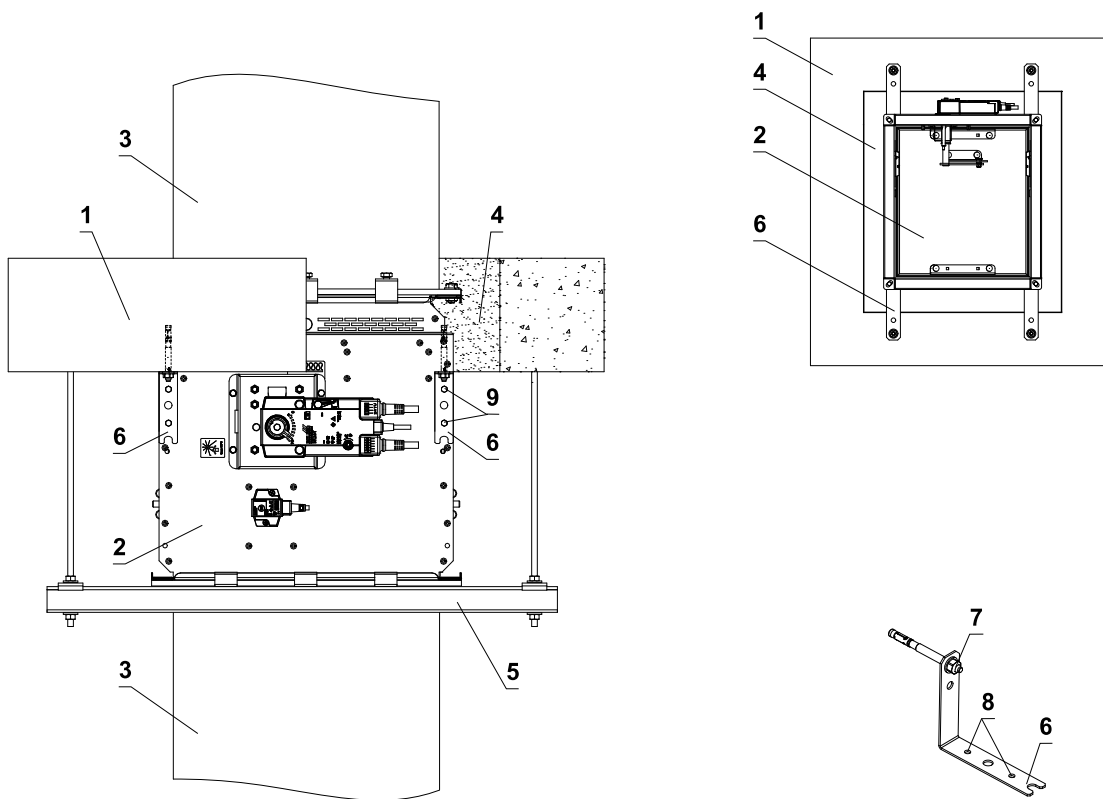

- 1 Solid ceiling construction
- 2 FDMB
- 3 Duct
- 4 Penetration
- 5 Profile with threaded rod → see page 74
- 6 Fixing element/steel bracket for fixing the damper to the wall (optional accessories from MANDÍK, a.s. or sheet metal min. thickness 2 mm and min. width 25 mm)
- 7 Nut M8 with anchor
- 8 Installation holes
- 9 Screw assembly M6 (screw M6x10, nut M6)

■ The method of attachment must follow the minimum requirements for attachment and connection of ductwork in accordance with national regulations. Also, the elements can be suspended from the top, or supported from bottom, or fastened from the side.

Example of duct connection

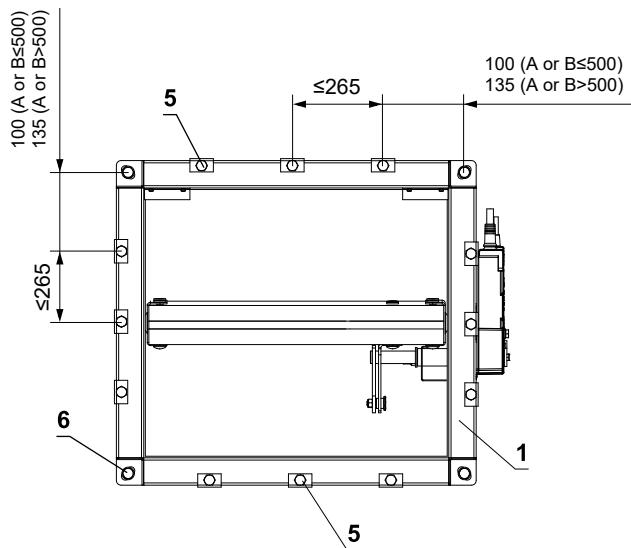
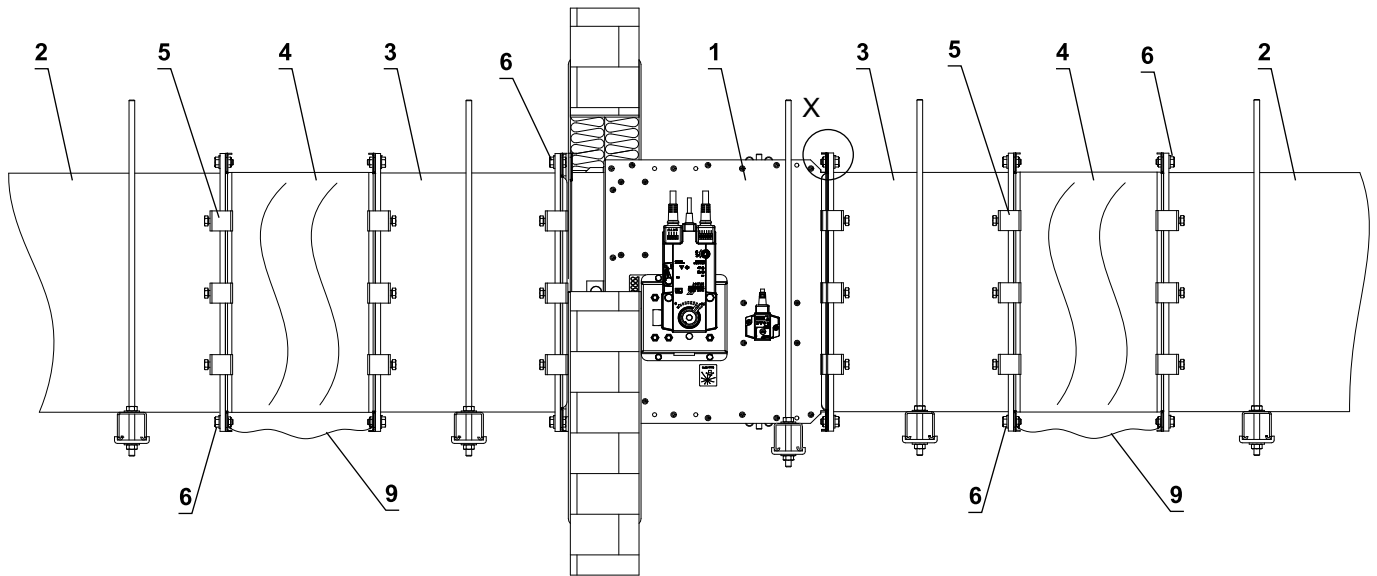

Electrically conductive connection

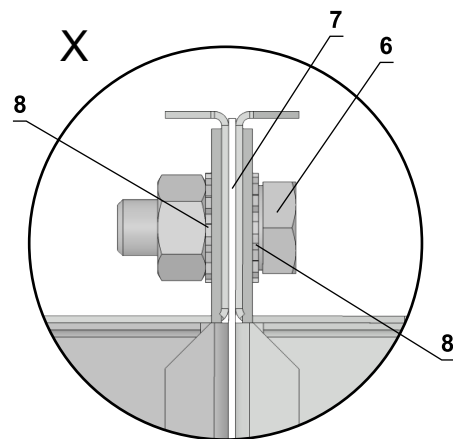

* at least one connection must be electrically conductive

- 1 FDMB
- 2 Duct
- 3 Extension piece (if required)
- 4 Damping pad
- 5 Steel clamp min. screw M8
- 6 Screw assembly M8 (screw M8x20 mm, 2 pcs toothed lock washer M8, nut M8) *
- 7 Sealing
- 8 Toothed lock washer M8
- 9 Protective bonding conductor

VI. TECHNICAL DATA

Pressure loss

Pressure loss calculation

$$\Delta p = \xi \cdot \rho \cdot \frac{w^2}{2}$$

Δp	[Pa]	pressure loss
w	[m/s]	air flow speed in nominal damper section
ρ	[kg/m ³]	air density
ξ	[-]	coefficient of local pressure loss for the nominal damper section → see page 79

Determination of pressure loss by using diagram $\rho = 1,2 \text{ kg/m}^3$

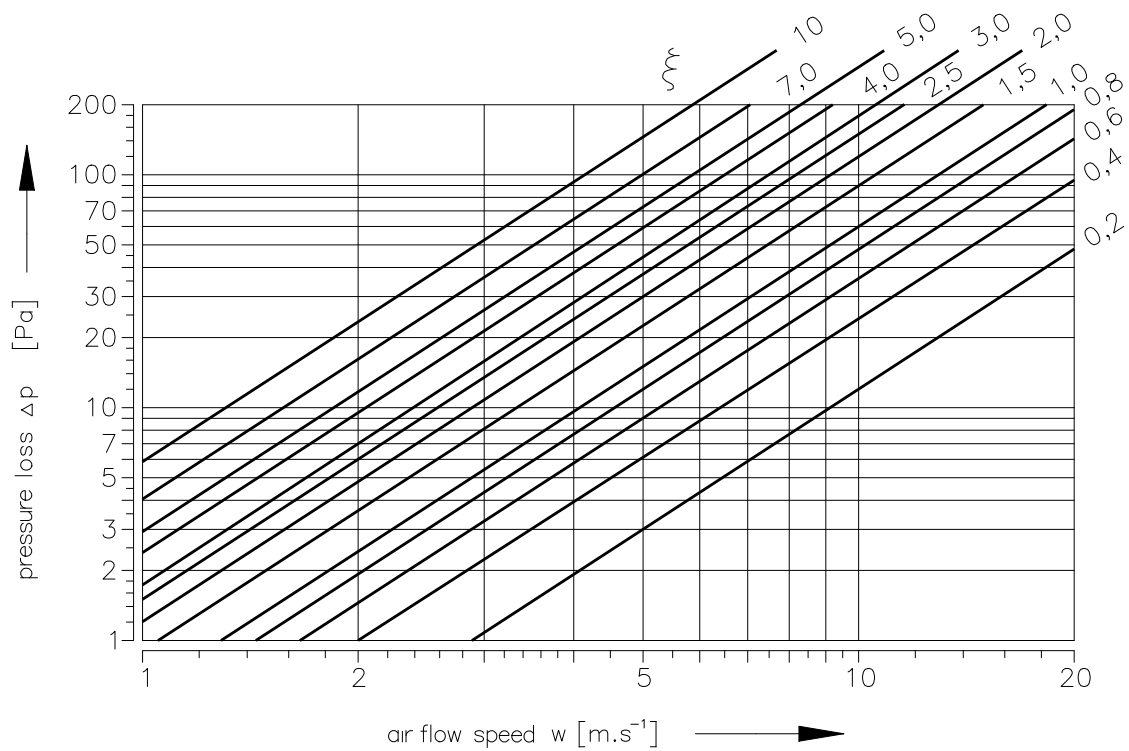

Coefficient of local pressure loss

A	B													
	100	110	125	140	150	160	180	200	225	250	280	300	315	355
100	19,025	15,910	11,370	7,983	6,374	5,264	2,959	2,962	2,162	1,548	1,399	-	-	-
110	15,690	12,678	9,499	6,910	5,576	4,528	2,743	2,649	1,978	1,459	1,299	-	-	-
125	11,247	9,984	7,440	5,444	4,529	3,773	2,461	2,208	1,744	1,327	1,163	-	-	-
140	8,673	7,669	5,933	4,489	3,755	3,195	2,204	1,893	1,552	1,217	1,044	-	-	-
150	7,408	6,620	5,144	4,007	3,388	2,899	2,091	1,728	1,443	1,160	0,985	-	-	-
160	6,659	5,813	4,748	3,683	3,129	4,771	3,458	2,717	2,285	1,813	1,538	1,407	1,327	1,165
180	4,528	4,270	3,630	3,000	2,644	4,102	3,251	2,351	2,016	1,676	1,342	1,221	1,136	0,986
200	4,490	4,170	3,466	2,807	2,446	3,701	2,951	2,105	1,867	1,554	1,302	1,113	1,052	0,933
225	4,220	3,969	3,379	2,767	2,431	3,654	2,873	2,056	1,726	1,475	1,226	1,067	1,029	0,917
250	4,120	3,904	3,306	2,744	2,405	3,588	2,793	2,005	1,675	1,386	1,155	1,033	0,987	0,893
280	3,520	3,404	3,005	2,551	2,266	3,411	2,692	1,975	1,599	1,341	1,123	0,986	0,916	0,822
300	3,307	3,225	2,876	2,457	2,189	3,288	2,599	1,903	1,536	1,315	1,101	0,974	0,911	0,787
315	3,219	3,139	2,760	2,338	2,072	3,102	2,454	1,833	1,489	1,289	0,988	0,933	0,833	0,721
355	2,914	2,842	2,550	2,195	1,963	2,955	2,302	1,796	1,412	1,199	0,956	0,902	0,799	0,678
400	3,291	3,125	2,665	2,196	1,926	2,833	2,159	1,703	1,356	1,126	0,931	0,825	0,711	0,635
450	-	-	2,690	2,176	1,884	2,732	2,055	1,623	1,302	1,103	0,852	0,777	0,677	0,599
500	-	-	2,590	2,110	1,836	2,670	1,988	1,587	1,251	1,025	0,796	0,725	0,618	0,529
550	-	-	1,976	1,885	1,731	4,219	2,941	2,237	1,687	1,402	1,156	1,039	0,968	0,827
560	-	-	1,978	1,884	1,727	4,194	2,922	2,222	1,623	1,392	1,147	1,031	0,910	0,820
600	-	-	-	1,841	1,696	4,104	2,857	2,170	1,573	1,357	1,117	1,004	0,935	0,797
630	-	-	-	1,828	1,682	4,046	2,814	2,137	1,553	1,334	1,098	0,986	0,918	0,782
650	-	-	-	1,814	1,670	4,010	2,788	2,116	1,526	1,320	1,086	0,975	0,908	0,773
700	-	-	-	-	1,664	3,975	2,759	2,098	1,515	1,297	1,071	0,965	0,892	0,761
710	-	-	-	-	1,645	3,918	2,720	2,062	1,496	1,284	1,055	0,947	0,881	0,749
750	-	-	-	-	1,630	3,865	2,682	2,032	1,475	1,264	1,037	0,931	0,866	0,736
800	-	-	-	-	1,612	3,808	2,640	1,999	1,445	1,241	1,018	0,913	0,849	0,721
900	-	-	-	-	-	3,715	2,572	1,946	1,414	1,205	0,988	0,885	0,822	0,697
1000	-	-	-	-	-	3,643	2,519	1,904	1,395	1,177	0,964	0,863	0,801	0,679

A	B													
	400	450	500	550	560	600	630	650	700	710	750	800	900	1000
100	-	-	-	-	-	-	-	-	-	-	-	-	-	-
110	-	-	-	-	-	-	-	-	-	-	-	-	-	-
125	-	-	-	-	-	-	-	-	-	-	-	-	-	-
140	-	-	-	-	-	-	-	-	-	-	-	-	-	-
150	-	-	-	-	-	-	-	-	-	-	-	-	-	-
160	1,040	2,025	1,874	1,761	1,741	1,672	1,627	1,601	1,598	1,532	1,493	1,452	1,386	1,336
180	0,922	1,676	1,548	1,451	1,434	1,375	1,337	1,315	1,289	1,256	1,224	1,180	1,133	1,090
200	0,801	1,445	1,332	1,246	1,232	1,179	1,146	1,126	1,106	1,074	1,046	1,015	0,965	0,928
225	0,781	1,239	1,172	1,075	1,035	0,998	0,965	0,938	0,926	0,905	0,873	0,856	0,822	0,803
250	0,736	1,113	1,021	0,952	0,940	0,898	0,871	0,855	0,831	0,813	0,790	0,765	0,725	0,695
280	0,713	0,996	0,912	0,849	0,880	0,800	0,775	0,760	0,742	0,722	0,701	0,678	0,641	0,613
300	0,692	0,937	0,857	0,797	0,786	0,750	0,726	0,712	0,689	0,675	0,655	0,633	0,599	0,572
315	0,634	0,900	0,822	0,764	0,754	0,718	0,695	0,681	0,662	0,646	0,626	0,605	0,572	0,546
355	0,588	0,821	0,749	0,694	0,685	0,651	0,630	0,617	0,603	0,584	0,566	0,546	0,514	0,490
400	0,527	0,757	0,689	0,637	0,628	0,597	0,577	0,565	0,543	0,534	0,516	0,498	0,468	0,445
450	0,507	0,705	0,640	0,591	0,583	0,553	0,534	0,522	0,503	0,493	0,476	0,458	0,430	0,408
500	0,460	0,666	0,603	0,556	0,548	0,520	0,501	0,490	0,482	0,462	0,446	0,429	0,401	0,380
550	0,719	0,635	0,575	0,529	0,521	0,494	0,476	0,465	0,441	0,437	0,422	0,405	0,379	-
560	0,713	0,630	0,570	0,524	0,517	0,489	0,471	0,461	0,448	0,433	0,418	0,401	-	-
600	0,692	0,611	0,552	0,507	0,500	0,473	0,455	0,445	0,426	0,418	0,403	0,387	-	-
630	0,678	0,598	0,540	0,496	0,489	0,462	0,445	0,435	0,418	0,408	0,393	-	-	-
650	0,670	0,590	0,533	0,490	0,482	0,456	0,439	0,428	0,414	0,402	0,387	-	-	-
700	0,656	0,581	0,527	0,483	0,476	0,444	0,431	0,421	0,409	0,398	-	-	-	-
710	0,648	0,571	0,515	0,472	0,465	0,439	0,422	0,412	0,399	-	-	-	-	-
750	0,636	0,560	0,504	0,462	0,455	0,429	0,413	0,403	-	-	-	-	-	-
800	0,623	0,547	0,493	0,451	0,444	0,419	-	-	-	-	-	-	-	-
900	0,602	0,528	0,474	0,434	-	-	-	-	-	-	-	-	-	-
1000	0,585	0,512	0,460	-	-	-	-	-	-	-	-	-	-	-

Noise data

Level of acoustic output corrected with filter A

$$L_{WA} = L_{W1} + 10 \log(S) + K_A$$

L_{WA}	[dB(A)]	level of acoustic output corrected with filter A
L_{W1}	[dB]	level of acoustic output L_{W1} related to the 1 m ² section
S	[m ²]	duct cross section
K_A	[dB]	correction to the weight filter A

Level of acoustic output in octave ranges

$$L_{Woct} = L_{W1} + 10 \log(S) + L_{rel}$$

L_{Woct}	[dB]	spectrum of acoustic output in octave range
L_{W1}	[dB]	level of acoustic output L_{W1} related to the 1 m ² section
S	[m ²]	duct cross section
L_{rel}	[dB]	relative level expressing the shape of the spectrum

Tables of acoustic values

Level of acoustic output L_{W1} [dB] related to the 1 m ² section															
w [m/s]	ξ [-]														
	0,2	0,3	0,4	0,5	0,6	0,7	0,8	0,9	1	1,5	2	2,5	3	4	5
2	15,5	18,7	20,9	22,6	24	25,2	26,3	27,2	28	31,2	33,4	35,1	36,5	38,8	40,5
3	26,1	29,2	31,5	33,2	34,6	35,8	36,9	37,8	38,6	41,7	44	45,7	47,1	49,4	51,1
4	33,6	36,7	39	40,7	42,1	43,3	44,3	45,3	46,1	49,2	51,5	53,2	54,6	56,9	58,6
5	39,4	42,5	44,8	46,5	47,9	49,1	50,2	51,1	51,9	55	57,3	59	60,4	62,7	64,4
6	44,1	47,3	49,5	51,3	52,7	53,9	54,9	55,8	56,6	59,8	62	63,8	65,2	67,4	69,2
7	48,2	51,3	53,5	55,3	56,7	57,9	58,9	59,8	60,7	63,8	66,1	67,8	69,2	71,4	73,2
8	51,6	54,8	57	58,8	60,2	61,4	62,4	63,3	64,1	67,3	69,5	71,3	72,7	74,9	76,7
9	54,7	57,9	60,1	61,8	63,2	64,4	65,5	66,4	67,2	70,4	72,6	74,3	75,7	78	79,7
10	57,4	60,6	62,8	64,6	66	67,2	68,2	69,1	70	73,1	75,3	77,1	78,5	80,7	82,5
11	59,9	63,1	65,3	67,1	68,5	69,7	70,7	71,6	72,4	75,6	77,8	79,6	81	83,2	85
12	62,2	65,4	67,6	69,3	70,7	71,9	73	73,9	74,7	77,9	80,1	81,8	83,2	85,5	87,2

Correction to the weight filter A											
w [m/s]	2	3	4	5	6	7	8	9	10	11	12
K_A [dB]	-15	-11,8	-9,8	-8,4	-7,3	-6,4	-5,7	-5	-4,5	-4	-3,6

Relative level expressing the shape of the spectrum L_{rel}								
w [m/s]	f [Hz]							
	63	125	250	500	1000	2000	4000	8000
2	-4,5	-6,9	-10,9	-16,7	-24,1	-33,2	-43,9	-56,4
3	-3,9	-5,3	-8,4	-13,1	-19,5	-27,6	-37,4	-48,9
4	-3,9	-4,5	-6,9	-10,9	-16,7	-24,1	-33,2	-43,9
5	-4	-4,1	-5,9	-9,4	-14,6	-21,5	-30,0	-40,3
6	-4,2	-3,9	-5,3	-8,4	-13,1	-19,5	-27,6	-37,4
7	-4,5	-3,9	-4,9	-7,5	-11,9	-17,9	-25,7	-35,1
8	-4,9	-3,9	-4,5	-6,9	-10,9	-16,7	-24,1	-33,2
9	-5,2	-3,9	-4,3	-6,4	-10,1	-15,6	-22,7	-31,5
10	-5,5	-4	-4,1	-5,9	-9,4	-14,6	-21,5	-30
11	-5,9	-4,1	-4	-5,6	-8,9	-13,8	-20,4	-28,8
12	-6,2	-4,3	-3,9	-5,3	-8,4	-13,1	-19,5	-27,6

VII. MATERIAL, FINISHING

- Damper casings are made from galvanized sheet metal without further surface treatment.
- Damper blades are made from fire resistant asbestos free boards made of mineral fibres.
- Manual control have cover made of mechanically resistant and durable plastic and the other parts are galvanized without further surface treatment.
- Thermal fuses are made of sheet brass, thickness 0,5 mm.
- Fasteners and springs are galvanized.
- According to the customer's requirements, dampers can be made of stainless steel material.

Specifications for stainless-steel design:

- Class A2 – Food-grade stainless steel (AISI 304 – EN 1.4301)
- Class A4 – Chemistry-grade stainless steel (AISI 316, 316L – EN 1.4401, EN 1.4404)

The respective stainless steel is the material for all components that are located or entering the damper inner space; components outside the damper casing are typically from galvanised sheet metal (fasteners for mounting the actuator or manual control, mechanical components except Item 4), frame components.

The following components, including the fasteners, are made from stainless steel at all times:

- 1) Damper casing and all components permanently attached
- 2) Blade holders including pins, metal parts of blades
- 3) Control components inside the damper (L-profile, pin with lever, rod, fasteners)
- 4) Parts of a manual control entering the inner space of a damper casing (lower sheet of a manual control, lock holder "1", lock lever "2", closing spring, 8 dia. stopper pin, manual control pin)
- 5) Inspection opening cover including the stirrup and fasteners (if they are parts of the cover)
- 6) Bearing for torque transfer from the lever with pin on the blade L-profile (made from AISI 440C)

The damper blade is made from a board of homogeneous material Promatect-MST, thickness 30 mm.

Thermal fuse is identical for all material variants of the dampers. Upon specification by customer, the thermal fuse can be made from A4 from stainless steel sheet metal.

Thermoelectric activation device BAT is modified for stainless-steel variant of the dampers; standard galvanised screws are replaced with stainless-steel M4 screws of corresponding class. Damper casing has stainless-steel riveting M4 nuts.

Plastic, rubber and silicon components, sealants, foaming tapes, glass-ceramic seals, housings, brass bearings of the blade, actuators, and end switches are identical for all material variants of the dampers.

Some fasteners and components are only available in one class of stainless steel; the type will be used in all stainless-steel variants.

The damper blade in the variant for chemical environments (Class A4) is always treated with a coating of chemically resistant Promat SR.

Any other requirements for the design will be considered atypical and will be addressed on an individual basis.

VIII. TRANSPORTATION, STORAGE AND WARRANTY

Logistic terms

- Dampers are delivered on pallets. As standard, the dampers are wrapped in plastic foil for protection during transport and must not be used for long-term storage. Temperature changes during transport can cause condensation of water inside the packaging and thereby cause corrosion of materials used in the dampers (e.g. white corrosion on zinc-coated items or mould on calcium silicate). Therefore, it is necessary to remove the transport packaging immediately after unloading to allow air to circulate around the product.
- The dampers must be stored in clean, dry, well ventilated and dust-free environment out of direct sunlight. Ensure protection against moisture and extreme temperatures (minimum temperature +5°C). The dampers must be protected against mechanical and accidental damage prior to installation.
- Another required packaging system should be approved and agreed by manufacturer. Packaging material is not returnable in case that another packaging system (material) is required and used and it is not included into final price of damper.
- Dampers are transported by box freight vehicles without direct weather impact, there must not occur any shocks and ambient temperature must not exceed +50°C. Dampers must be protected against impact when transported and manipulated. During transportation, the damper blade must be in the "CLOSED" position.
- Dampers must be stored indoor in environment without any aggressive vapours, gases or dust. Indoor temperature must be in the range from -30°C to +50°C and maximum relative humidity 95%.

Warranty

- The manufacturer provides a warranty of 24 months from the date of dispatch for the dampers.
- In case of using a Schischek actuator, the manufacturer provides a 12-month warranty for the actuator from the date of shipment.
- The warranty for fire dampers FDMB, provided by the manufacturer, is completely void if actuating, closing and control devices are unprofessionally handled by untrained workers or if electric components, i.e. limit switches, actuators, communication and supply devices and thermoelectric activation devices are dismantled.
- The warranty is void if dampers are used for other purposes, devices and working conditions than those allowed by these technical conditions or if the dampers are mechanically damaged during handling.
- If the dampers are damaged by transport, a record must be written down with the forwarder at reception for later complaint.

IX. ASSEMBLY, ATTENDANCE AND MAINTENANCE

- Assembly, maintenance and damper function check can be done only by qualified and trained person, i.e. "AUTHORIZED PERSON" according to the manufacturer documentation. All works done on the fire dampers must be done according international and local norms and laws.
- All effective safety standards and directives must be observed during damper assembly.
- To ensure reliable damper function it is necessary to avoid blocking the actuating mechanism and contact surfaces with collected dust, fibre and sticky materials and solvents.
- Flange and screw joints must be conductively connected to protect against dangerous contact. 2 galvanized lock washers that are placed under the head of one screw and a fastened nut are used for conductive connection.

Manual operation - actuator control without electric voltage

- A special wrench (part of the actuator) can be used to manually turn the damper blade to any position. When the wrench is turned in the direction of the arrow, the damper blade rotates to its open position. As the blade rotation is stopped, in every position, the actuator will be locked. Unlocking is possible even manually as per instructions on the actuator, or by the activation of the supply voltage.
- If the actuator is manually locked, the damper blade will not close in the event of a fire after the activation of the thermoelectric activation device BAT. To restore correct damper operation, the actuator must be unlocked (manually or by applying power supply).

Limit switches

- If the damper is equipped with limit switches and these switches are not used during operation (e.g. because of a project change), they can be left on the damper and not connected (they need not be dismantled).
- On the other hand, if the limit switch is to be added to the damper design, the change can be implemented by change kit.
- These facts must be recorded in the respective operation documentation of the damper (record books of the damper, fire logs, etc.) and subsequently, adequate function checks must be carried out.

Installation / fixing the damper

- The damper casing shall not be deformed in the course of bricking in.
- Once the damper is built in, the damper blade shall not grind on the damper casing during opening or closing.

Protection of the damper casing against buckling during installation, especially for large sizes!

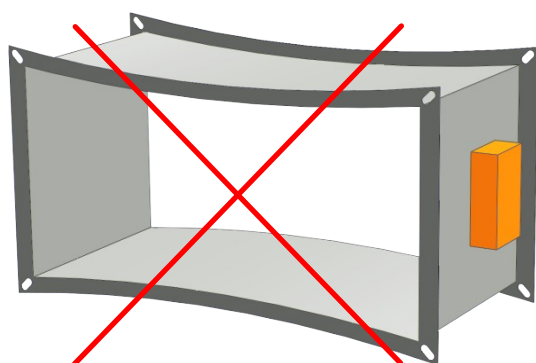

WRONG!

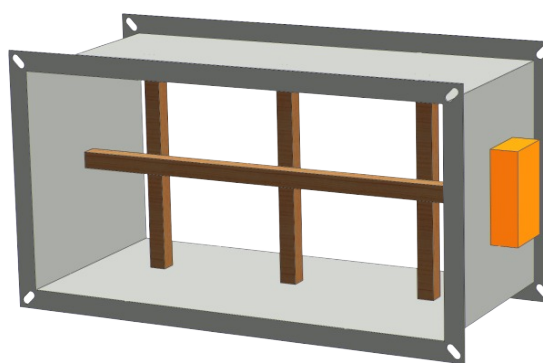

Reinforcement of the casing with wooden beams

Change of manual control for the actuator or vice versa

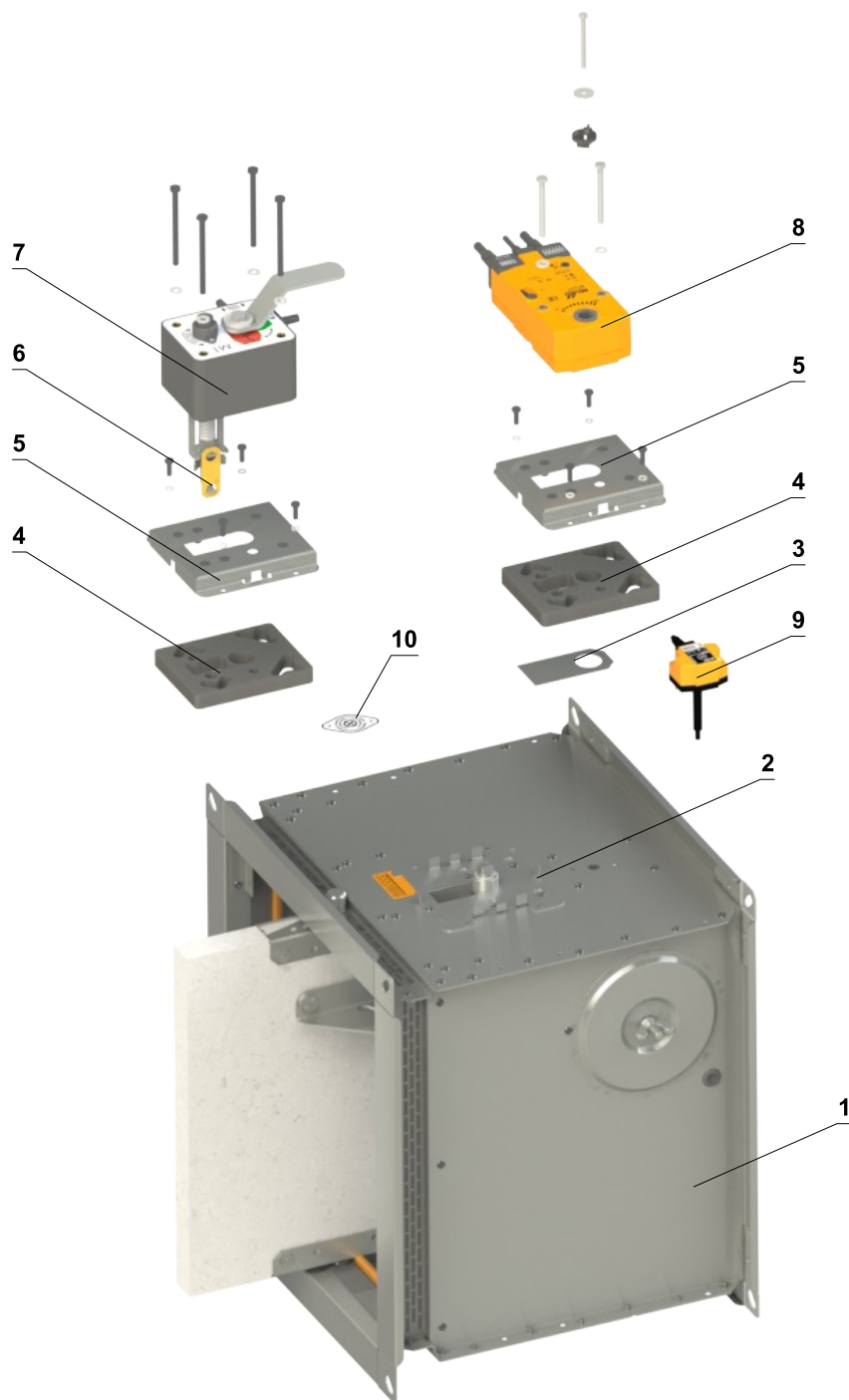

- | | |
|------------------------------|--|
| 1 Damper | 6 Thermal fuse |
| 2 Mouting plate | 7 Manual control |
| 3 Sealing cover | 8 Spring return actuator |
| 4 Sealing of a mouting plate | 9 Thermoelectric activation device BAT |
| 5 Cover of a mouting plate | 10 Sensor sticker |

Reinforcing frame VRM-B

- If the damper is installed outside the fire separation construction with insulation from ROCKWOOL and fire resistance is \geq EI 90 S, VRM-B reinforcement frame must be used.
- For lower fire resistance than EI 90 S, VRM-B reinforcement frame is not necessary!
- Glue K84 is not included in the package

Fixing of reinforcing frame VRM-B to the damper casing

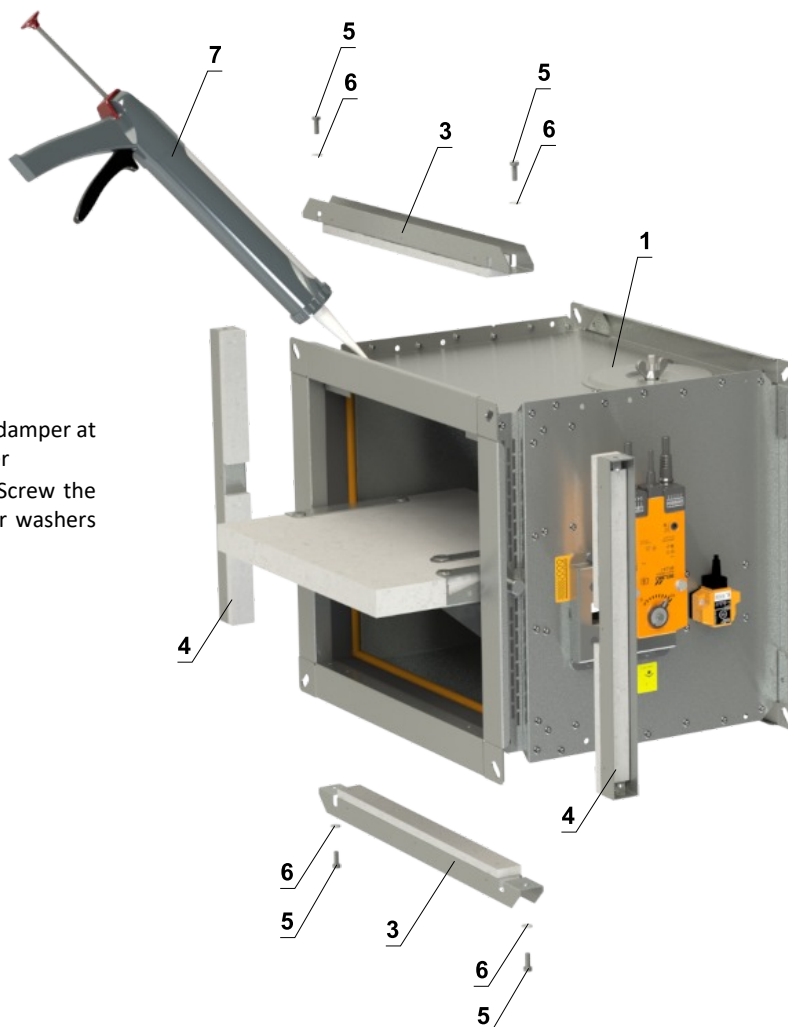
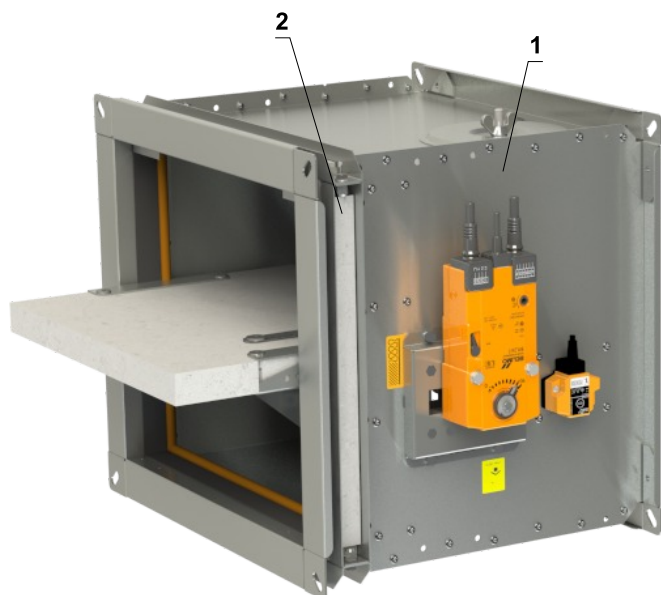

Installation procedure

- 1) Apply glue PROMAT K-84 on the entire surface of the damper at the place of perforation on all four sides of the damper
- 2) Attach parts A and B of the VRM-B to the damper. Screw the parts together using four M6x16 mm DIN 933 + four washers M6/6,4 DIN 7349.

- 1 FDMB
- 2 VRM-B
- 3 Part A of VRM-B
- 4 Part B of VRM-B
- 5 Hexagon socket bolt M6x16 mm DIN 933
- 6 Washer M6/6,4 DIN 7349
- 7 Glue PROMAT K-84

Reinforcing frame VRM2-B

- If the damper is installed outside the fire separation construction with insulation from ISOVER and fire resistance is \geq EI 90 S, VRM2-B reinforcement frame must be used.
- For lower fire resistance than EI 90 S, VRM2-B reinforcement frame is not necessary!
- Glue K84 is not included in the package

Fixing of reinforcing frame VRM2-B to the damper casing

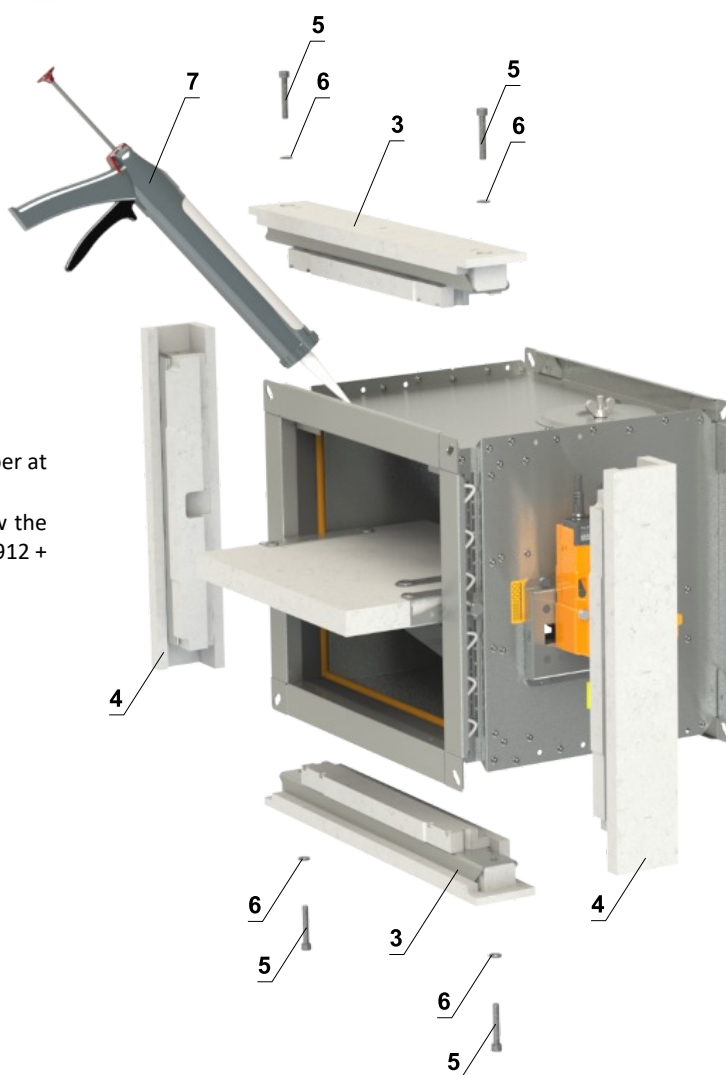
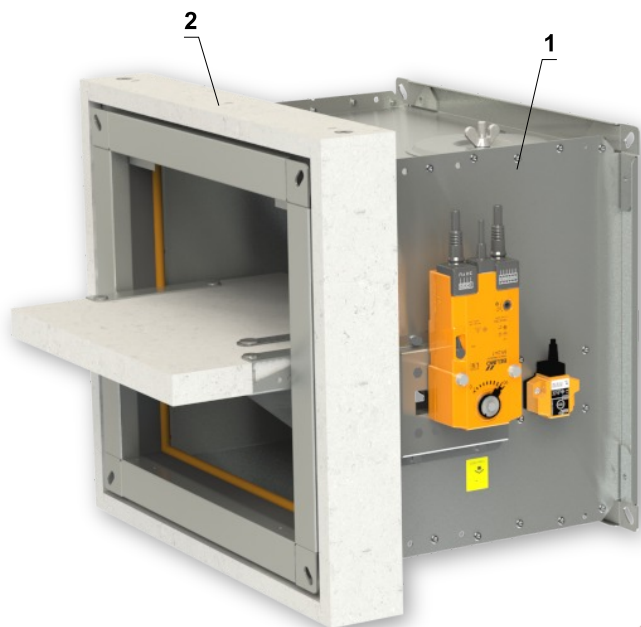

Installation procedure

- 1) Apply glue PROMAT K-84 on the entire surface of the damper at the place of perforation on all four sides of the damper
- 2) Attach parts A and B of the VRM2-B to the damper. Screw the parts together using four M8x50 hexagon socket bolts DIN 912 + four M8 washers DIN 7349.

- 1 FDMB
- 2 VRM2-B
- 3 Part A of VRM2-B
- 4 Part B of VRM2-B
- 5 Hexagon socket bolt M8x50 DIN 912
- 6 Washer M8/8,4 DIN 7349
- 7 Glue PROMAT K-84

Protective cladding boards

- Protective cladding boards must be used as part of the penetration filling of installation with Ablative Coated Batt.
- Can be ordered from MANDIK (installed on the damper or as an accessory) or can be sourced from local supplier
- If protective cladding boards are required, this must be specified in the ordering key
- Boards are made of PROMATECT-H, thickness 10 or 15 mm according to the damper size
- Glue K84 is not included in the package

Installation procedure

- 1) Apply K84 glue over the entire surface
- 2) Attach protective cladding boards to the damper and glue them to the casing

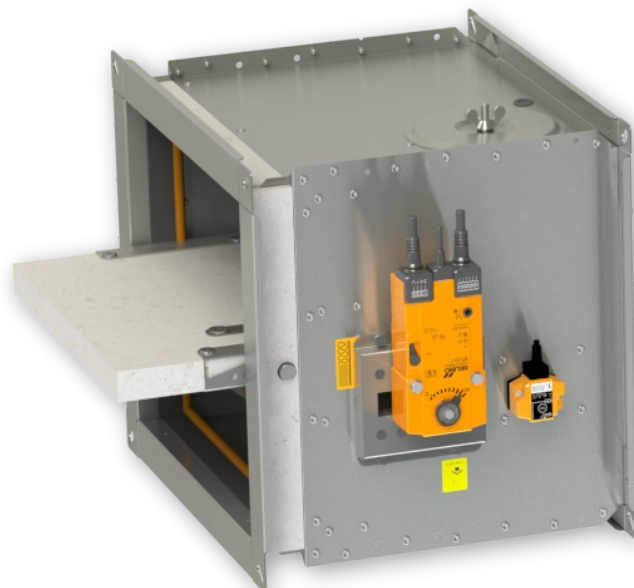
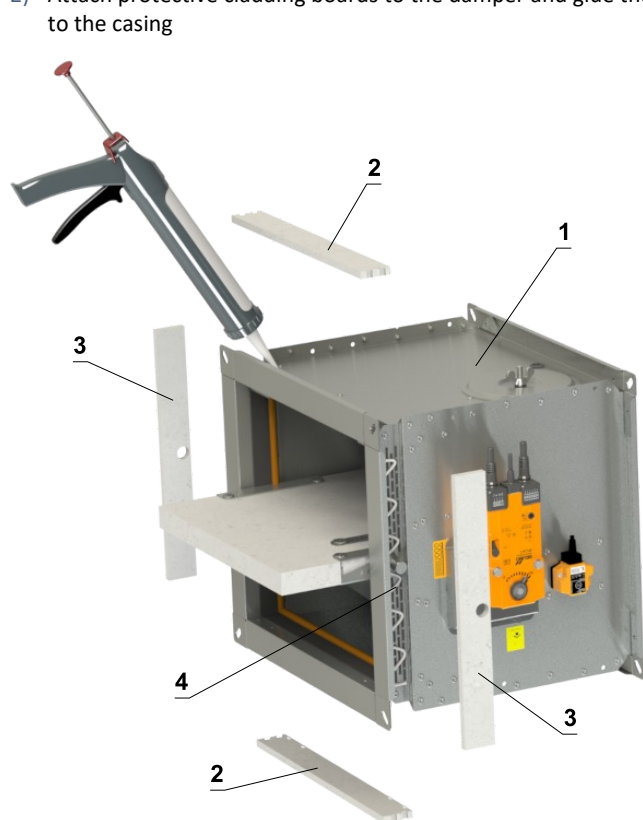

- 1 FDMB
- 2 Part A
- 3 Part B
- 4 Glue K-84 PROMAT

Part A (A ≥ 630)

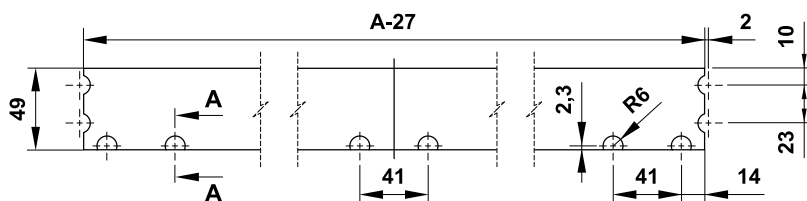

Part A (A < 630)

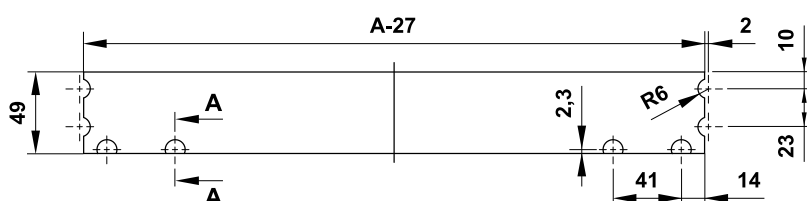

Part B

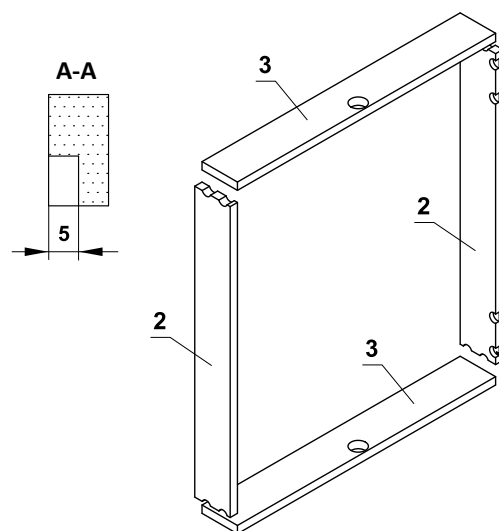
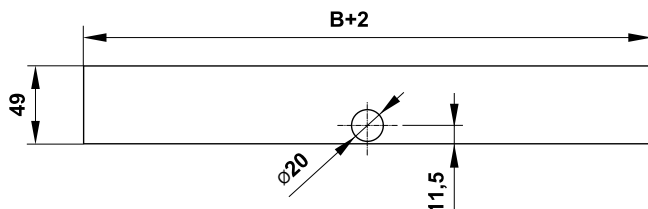

- Thickness of protective cladding boards according to the damper size:
- for AxB ≤ 500x400, thickness 10 mm
- for AxB > 500x400, thickness 15 mm

Commissioning and revisions

- Before putting the damper into operation, serviceability checks and functional tests must be carried out including testing of functionality of all electrical elements. After putting into operation these serviceability checks must be carried out at least twice a year. If no defect is found during two subsequent serviceability checks, these checks can be carried out once a year.
- In case that dampers are found unable to serve for their function for any cause, it must be clearly marked. The operator is obliged to ensure that the damper is put into condition in which it is ready for function and meanwhile he is obliged to provide the fire protection by another appropriate way.
- Results of regular checks, imperfections found and all-important facts connected with the damper function must be recorded in the "FIRE BOOK" and immediately reported to the operator.
- Before entering the dampers with actuator into operation after their assembly and by sequential checks. Check of blade rotation into the breakdown position "CLOSED" can be done after disconnecting the actuator supply (e.g. by pressing the test button at the thermoelectric activation device BAT or disconnecting the supply from ELECTRICAL FIRE SIGNALISATION). Check of blade rotation back into the "OPEN" position can be done after restoration of power supply (e.g. by releasing the test button or restoration of supply from ELECTRICAL FIRE SIGNALISATION). Without power supply, the damper can be operated manually and fixed in any required position. Release of the locking mechanism can be achieved manually or automatically by applying the supply voltage. It is recommended to provide periodical checks, maintenance and service actions on fire equipment by authorized persons. The authorized persons can be trained by producer, or by authorized distributor. All effective safety standards and directives must be observed during fire damper assembly.
- Visual inspection of proper damper installation, inner area of a damper, damper blade, contact surfaces and silicon seal.
- For regular or exceptional inspection of interior of fire damper, micro-camera device can be used. On each fire damper is an inspection opening. In the case of inspection by camera, take out the black rubber cap, insert the camera inside the damper, check interior and at the end of inspection, put the rubber cap back tightly to cover the empty hole.

Following checks must be carried out for dampers with manual control

Check of a manual control and thermal fuse

- **To check the function of the manual control proceed as follows:**
- Turn the damper blade to "CLOSED" position as follows:
 - The damper blade is in "OPEN" position.
 - Press the control button of the manual control to turn the damper blade to "CLOSED" position.
 - Check the damper blade rotation to "CLOSED" position.
 - Damper blade closing shall be smooth and fast, the control lever shall be in „CLOSED“ position.
- Turn the damper blade to "OPEN" position as follows:
 - Turn the control lever by 90°.
 - Check the damper blade rotation to "OPEN" position.
 - The lever will automatically lock in "OPEN" position.
- **Check of function and condition of the thermal fuse:**
 - To check the function and the status of the fuse it's possible to remove the manual control from the casing of the fire damper which is attached to the damper casing with four screws M6.
 - Removing the thermal fuse from the fuse holder of a manual control, checks its correct functionality.
 - The manual control is identified as M1 to M3, depending on the closing spring strength.

Following checks must be carried out for dampers with actuator

- Check the rotation of the blade to "CLOSED" failure position after disconnection the power supply of the actuator (e.g. by pressing the test button on the thermoelectric activation device BAT or by disconnection the power supply from electrical fire signalization). Check the rotation of the blade back to "OPEN" position by restoring the power supply to the actuator (e.g. by releasing the test button or by restoring the power supply from electrical fire signalization).

Following checks must be carried out for dampers with optical smoke detector

- The function checks of the optical smoke detector are to be carried out by employees of an authorized organization who have corresponding electrotechnical qualification and have been properly trained by the manufacturer. The function checks are to be carried out as a part of function checks of the fire dampers, at least 1x a year.
- For the function checks, the damper blade should be in "CLOSED" position with the fan off or with closed air regulation situated between the fan and the fire damper.
- Inspection opening disassembly
 - Release the covering lid by turning the wing nut and while turning the lid right or left release it from the security belt. Then tilt the lid and remove it from its original position.

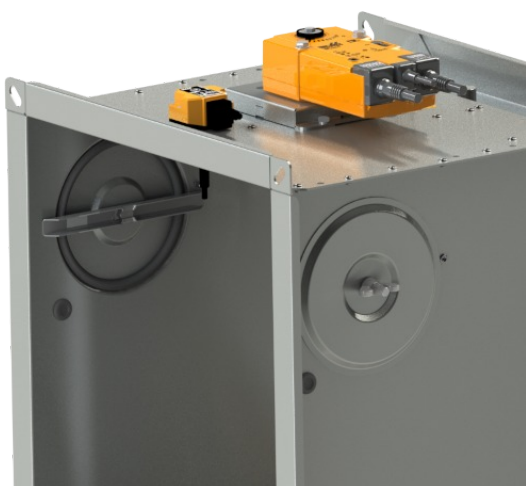

Inspection opening detail

- Ensure each damper is fully checked for operational capability, control should be initiated from the control system or by manual control. Damper blades should open and close correctly and operation should be visually inspected and documented prior to handover.

How to proceed after Tf1 or Tf2 fuses have been activated

- If the thermal fuse **Tf1** is interrupted (due to temperature outside the duct), it is necessary to replace the spring return actuator. → see page 10
- If the thermal fuse **Tf2** is interrupted (due to temperature inside the duct) , only the spare part ZBAT 72 (95/120/140) needs to be replaced (acc.to the activation temperature). → see page 10

X. ORDERING INFORMATIONS

Ordering key



EXAMPLES:

FDMB EN 500x250/375 .40 Q30-ZN

Fire damper FDMB, dimension 500x250 mm, built length 375 mm, control design with spring return actuator AC 230 V, standard activation temperature 72 °C, flange dimension 30 mm, galvanized material variant, without installation kit/frame, standard silicon seal.

FDMB EN 500x250/375 .40 120 E1 Q30-ZN IW G

Fire damper FDMB, dimension 500x250 mm, built length 375 mm, control design with spring return actuator AC 230 V, activation temperature 120 °C, with installation frame E1, flange dimension 30 mm, galvanized material variant, impregnation against humidity, rubber cold seal.

1| Fire damper type - FDMB

2| Country of destination

3| Damper dimensions A x B → see pages 16 to 21

"A" is the width of the damper
 "B" is the height of the damper

4| Built length - 375 mm

5| Damper design

.01	Manual control and thermal
.02	Manual control and thermal (Zone 1,2)
.11	Manual control and thermal with a terminal switch („CLOSED“)
.12	Manual control and thermal with a terminal switch („CLOSED“) (Zone 1,2)
.80	Manual control and thermal with two terminal switches („OPEN“, „CLOSED“)
.81	Manual control and thermal with two terminal switches („OPEN“, „CLOSED“) (Zone 1,2)
.40	With actuator BF 230-TN (BFL, BFN 230-T) - voltage AC 230 V
.41 *	With actuator BF 24-TN (BFL, BFN 24-T), with smoke detector ORS 142 K and with supply device BKN 230-24-MOD (voltage AC 230 V)
.42	With actuator ExMax-15-BF, with thermoelectric activation device ExPro-TT (Zone 1,2) - supply voltage range 24 to 230 VAC/DC
.50	With actuator BF 24-TN (BFL, BFN 24-T) - voltage AC/DC 24 V
.51 *	With actuator BF 24-TN (BFL, BFN 24-T), with smoke detector ORS 142 K (voltage AC/DC 24 V)
.63	With communication and supply device BKN 230-24-MOD, with actuator BF 24-TN-ST (BFL, BFN 24-T-ST)
.63S *	With communication and supply device BKN 230-24-MOD, with actuator BF 24-TN-ST (BFL, BFN 24-T-ST) and with smoke detector ORS 142 K

* For sizes A<160 mm or B<160 mm, the optical smoke detector ORS 142 K is not part of the fire damper and is supplied separately.

■ Detailed information for ATEX dampers (ZONE 1,2) → see Appendix

6| Activation temperature

Manual control		Spring return actuator control	
	72 °C *		72 °C *
104	104 °C	95	95 °C
147	147 °C	120	120 °C
		140	140 °C

* Standard activation temperature

8| Flange dimension

Q30	Flange width 30 mm
-----	--------------------

7| Installation kit/frame

	Without installation kit/frame
A	With protective cladding boards (for Ablative Coated Batt installation)
VRM-B	Reinforcing frame VRM-B
VRM2-B	Reinforcing frame VRM2-B
E1	Installation frame E1
E2*,**	Installation frame E2
E3*,**	Installation frame E3
E4*	Installation frame E4
E5	Installation frame E5
E6	Installation frame E6

* Available only for dampers with a built length of 375 mm

** Only comes installed on the damper and cannot be purchased separately

9| Material and other design options

ZN	Galvanized
A2	Stainless steel 1.4301 (AISI 304)
A4	Stainless steel 1.4404 (AISI 316L) - included damper blade impregnation against chemical - type PROMAT SR

10| Surface treatment

	Without surface treatment
IW	Damper blade impregnation, impregnating agent PROMAT 2000 - impregnation against humidity
IA	Damper blade impregnation, impregnating agent PROMAT SR - impregnation against chemical

11| Cold seal variant

	Silicone rubber *
G	Silicone-free rubber

* Standard cold seal

Accessories

Protective cladding boards



1| Accessory type - cladding boards

2| Fire damper type - FDMB

3| Damper dimensions A x B → see pages 16 to 21

Reinforcing frame VRM-B



1| Accessory type - reinforcing frame VRM-B

2| Fire damper type - FDMB

3| Damper dimensions A x B → see pages 16 to 21

Reinforcing frame VRM2-B



1| Accessory type - reinforcing frame VRM2-B

2| Fire damper type - FDMB

3| Damper dimensions A x B → see pages 16 to 21

Installation frame E





1| Installation frame type E1/E2/E3/E4/E5/E6

2| Fire damper type - FDMB

3| Damper dimensions A x B → see pages 16 to 21

Data label

- Data label is placed on the damper casing (example)

MANDÍK [®]		MANDÍK, a.s. Dobříšská 550, 267 24 Hostomice, Czech Republic	
FIRE DAMPER - XXXX		 MANUAL	
DIMENSION:			
SERIAL.NO.:		WEIGHT (kg):	
CLASSIFICATION:			
TPM XXX/XX	Cert. No.: 1391-CPR-XXXX/XXXX, DoP: PM/XXXX/XX/XX/X	XX	EN 15650:2010
			 1391

The producer reserves the right for innovations of the product.
For actual product information see www.mandik.com

MANDÍK[®]
www.mandik.com

