

MANDÍK[®]

ANEMOSTAT DIFFUSER
ROUND-TYPE WITH VANES

ALKM



These technical conditions state a row of the manufactured sizes and models of ceiling-,lamella- and round-type anemostat diffuser (further only anemostat) ALKM 250,300.400,500,600. It is valid for a production, designing, ordering, delivery, assembly and operation.

I. CONTENT

II. GENERAL	3
1. Description.....	3
2. Design.....	3
3. Dimensions and weights.....	4
4. Installation.....	5
III. TECHNICAL DATA	5
5. Basic parameters.....	5
6. Calculation and determining quantities.....	6
7. Aerodynamic data.....	7
IV. ORDERING INFORMATION	11
8. Ordering key.....	11
V. MATERIAL, FINISHING	11
9. Material.....	11
VI. TRANSPORTATION AND STORAGE	11
10. Logistics terms.....	11

II. GENERAL

1. Description

- 1.1.** Anemostat is a terminal, air-handling element for distribution of air.
It is suitable to be built-in to the ceiling in rooms with the ceiling height of approximately 2.6 - 4 m, for the purpose of inlet and outlet of air.
The outlet areas of anemostats are formed by rigid profiled vanes and their round construction allows for the inlet air to be spread evenly to all directions.
The effective outlet speed w_{ef} shall in no case be less than $2 \text{ m}\cdot\text{s}^{-1}$. If the speed is lower the air stream is torn off the ceiling.
- 1.2.** Anemostats are intended for environment protected against weather impacts with the classification of climatic conditions class 3K5, without condensation, frost, ice formation, and without water even from other sources than rain according to EN 60 72133, change A2.
Air flow must have a temperature between -20 to $+70 \text{ }^\circ\text{C}$.
Anemostats are suitable for systems without abrasive, chemical and adhesive particles.
- 1.3.** If is not noticed other way, all dimensions and weight are in millimeters and kilograms.

2. Design

- 2.1.** Front outlet surfaces are formed as diffuser frame and fixed profiled blades. The front outlet can be mounted and dismounted by using a central screw.
- 2.2.** Design according to connection to ductwork:
- horizontal connection (with round collars and UNIBOX from site according to request with or without regulating flap)
 - vertical connection (with round collars and UNIBOX from the top according to request with or without regulating flap)
 - Detailed description of Unibox is mentioned in technical data sheet TPM 139/19

Fig. 1 ALKM - horizontal connection

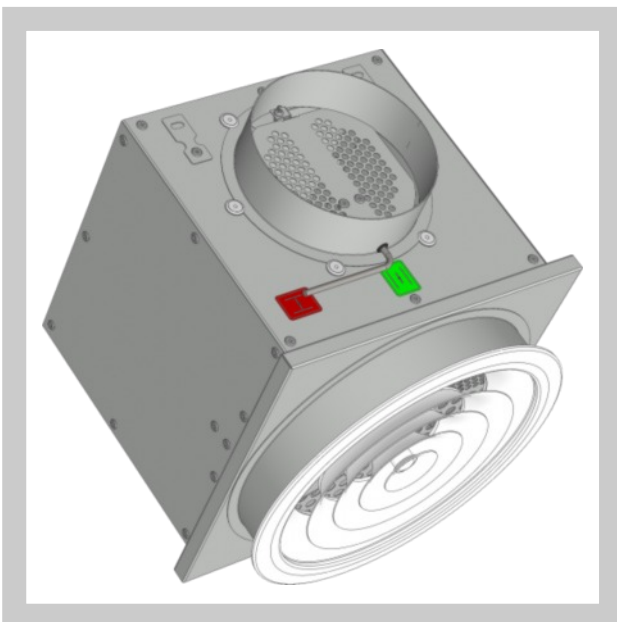
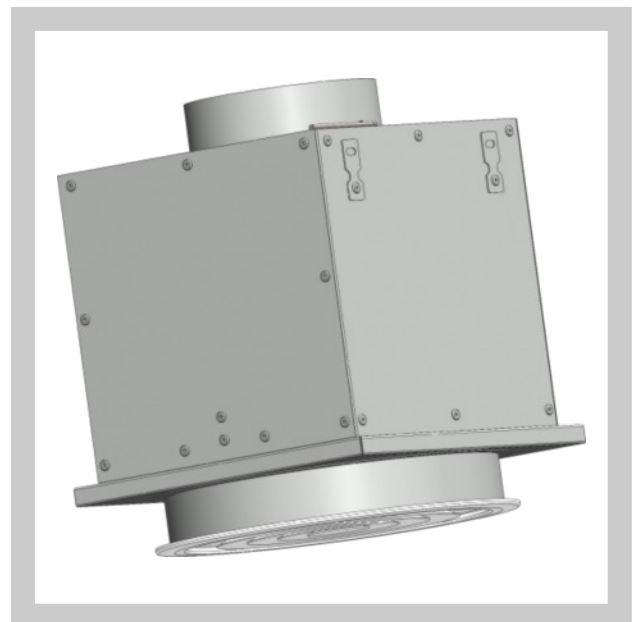

Fig. 2 ALKM - vertical connection



3. Dimensions and weights

3.1. Dimensions and weights of face plates

Tab. 3.1.1. Dimensions and weights of face plates

Size [mm]	øK [mm]	Weights [kg]
250	248	0,7
300	298	0,9
400	398	1,5
500	498	2,5
600	598	3,4

Fig. 3 Face plate

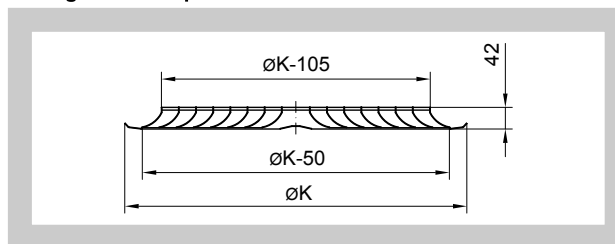

3.2. Connection box for horizontal / vertical connection and circular face plates.

Fig. 4 Horizontal / Vertical connection, circular face plates

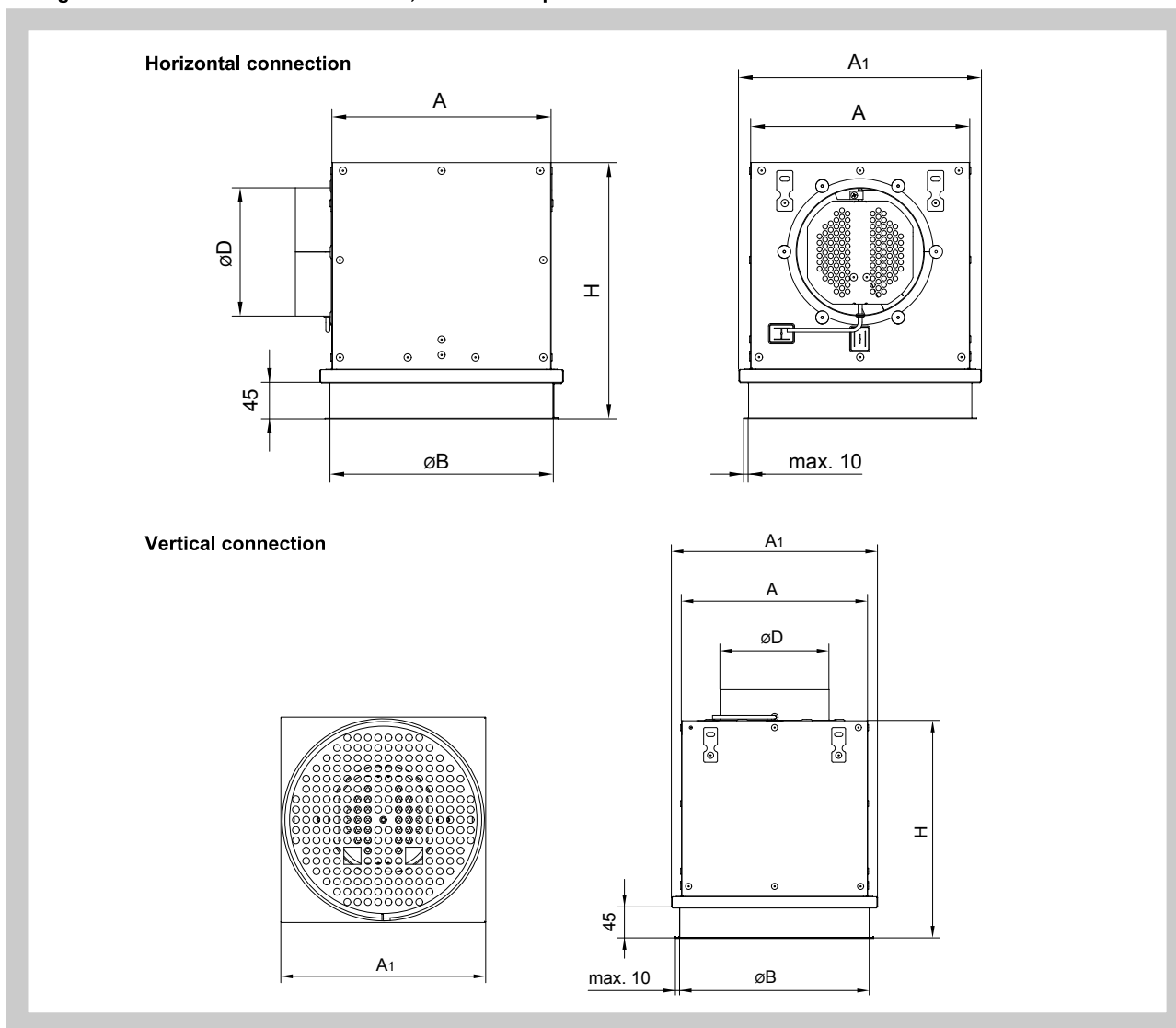

Tab. 3.2.1. Horizontal / Vertical connection, circular face plates - dimensions, weight

Size [mm]	A [mm]	A ₁ [mm]	øB [mm]	H [mm]	øD [mm]	Weights [kg]
250	220	247	215	270	158	2,2
300	270	297	275	290	158	3,1
400	370	390	365	300	198	4,3
500	470	490	465	300	198	5,7
600	572	592	570	350	248	7,8

4. Installation

4.1. Anemostats with the connecting box Location in the lower ceiling soffit and assembly of the front panel.

Fig. 5

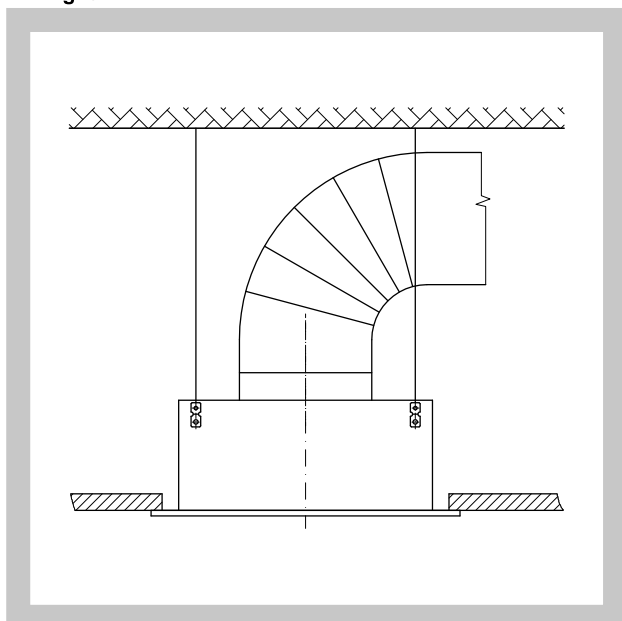
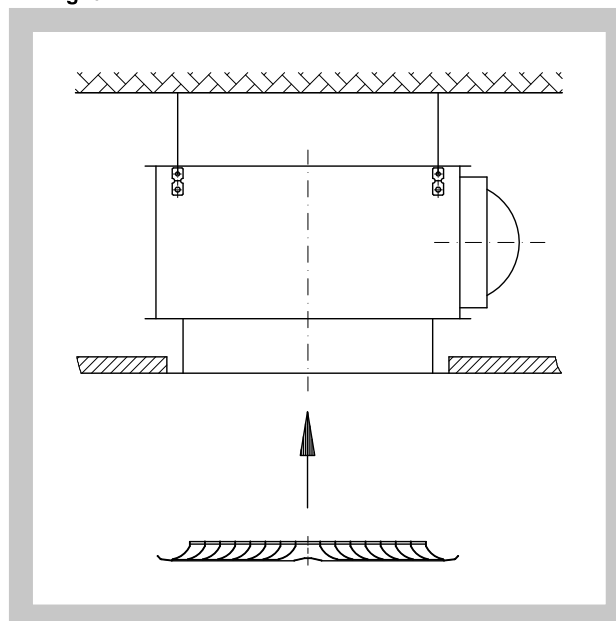

Fig. 6



Installation into lower ceiling and assembly of the face with the help of the central screw.

III. TECHNICAL DATA

5. Basic parameters

5.1. Basic parameters

Tab. 5.1.1. Basic parameters

Size	250	300	400	500	600
\dot{V}_{max} [m ³ .h ⁻¹]	250	400	700	1200	1800
\dot{V}_{min} [m ³ .h ⁻¹]	110	180	350	600	900
LW _{Amax} [dB(A)]	43	42	43	45	44
LW _{Amin} [dB(A)]	21	21	25	22	28
S _{ef} [m ²]	0,0118	0,0194	0,0399	0,0676	0,1026

6. Calculation and determining quantities

Fig. 7

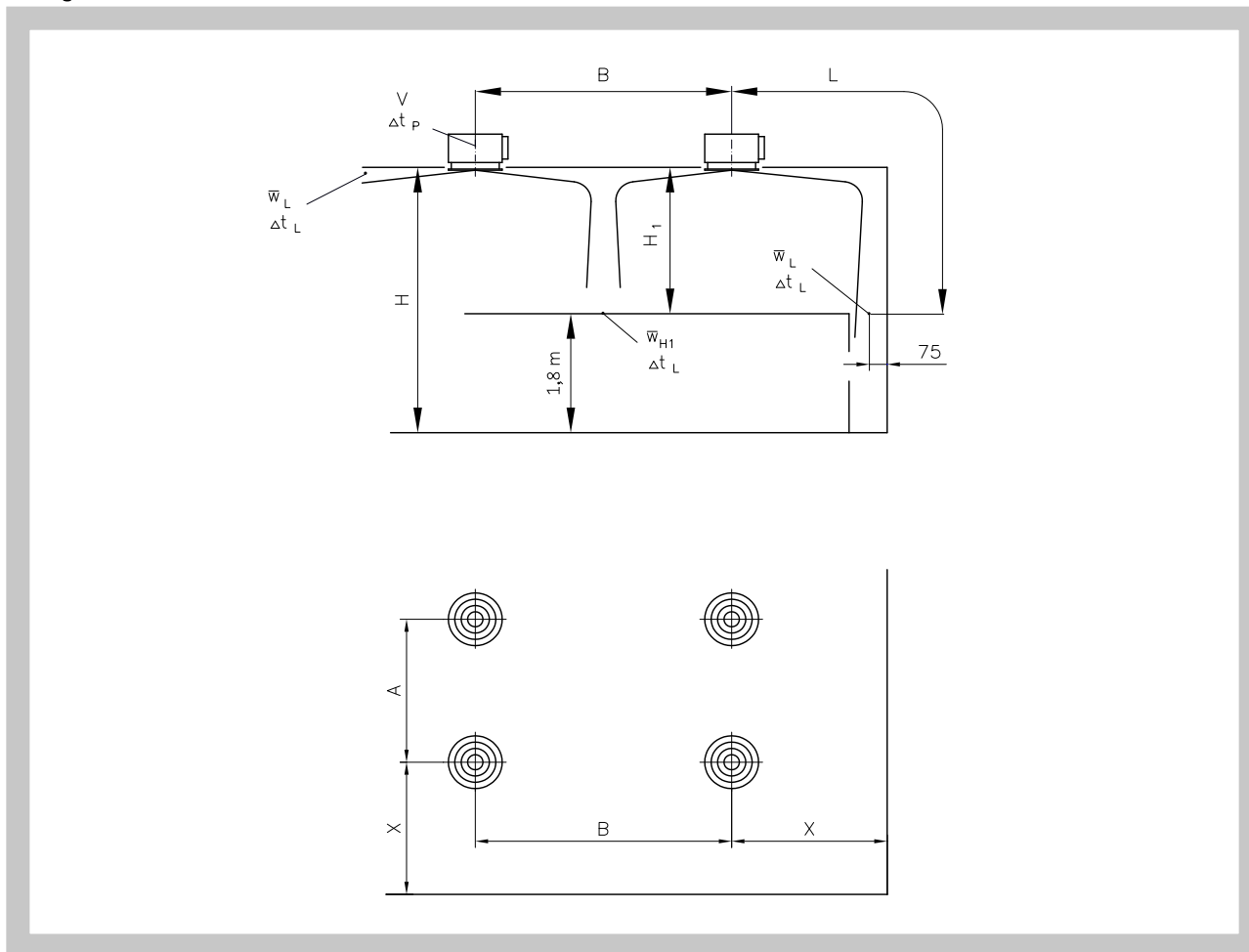

\dot{V}	[m ³ .h ⁻¹]	volume rate of flow of the air for one anemostat
A, B	[m]	distance between two anemostat
L	[m]	horizontal and vertical distance (X + H ₁)
X	[m]	distance of the anemostat center from the wall
H	[m]	height from ceiling
H ₁	[m]	distance between the ceiling and movement zone
\bar{w}_L	[m.s ⁻¹]	medium speed of flow on the wall
\bar{w}_{H1}	[m.s ⁻¹]	medium speed of flow between two anemometers in the distance H ₁
w _{ef}	[m.s ⁻¹]	output effective speed of the air
Δt _p	[K]	difference between the temperature of the supplied air and temperature of the air in the room
Δt _L	[K]	difference between the temperature of the flow in the distance L = A/2 + H ₁ or L = B/2 + H ₁ or L = X + H ₁
Δp _c	[Pa]	total pressure loss by ρ= 1,2 kg.m ³
L _{WA}	[dB(A)]	level of the acoustical output
S _{ef}	[m ²]	effective area of the anemostat

7. Aerodynamic data

7.1. Output effective velocity

Chart 7.1.1. Output effective velocity

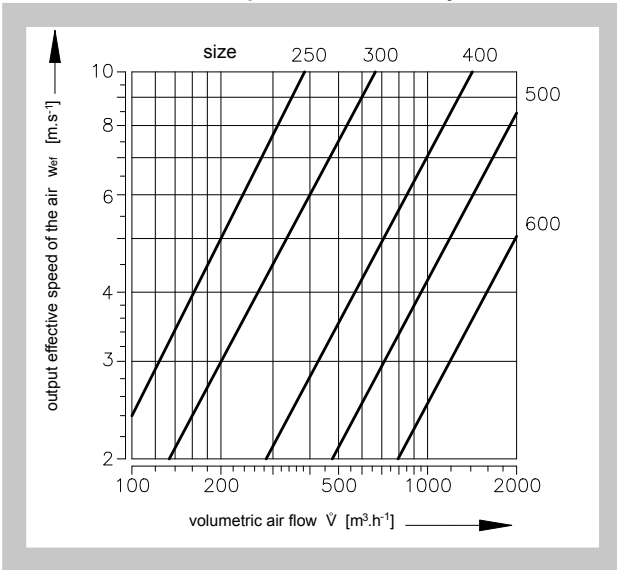
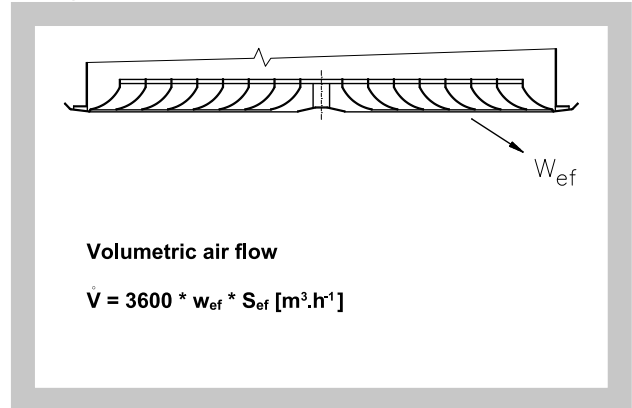

Fig. 8



7.2. Acoustical output and pressure losses

Chart 7.2.1. ALKM - horizontal connection - INLET

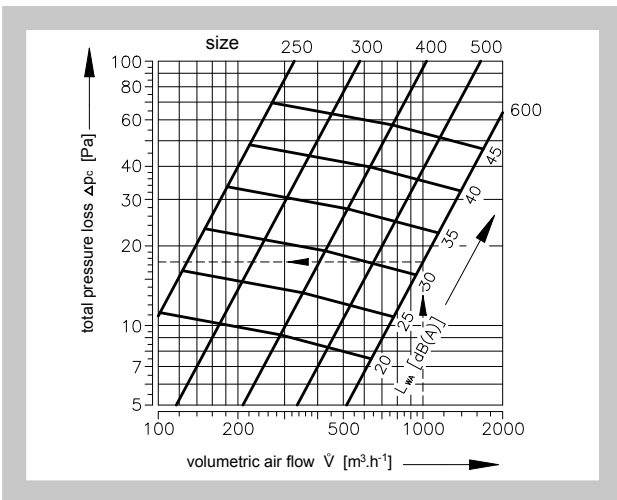

Chart 7.2.2. ALKM - horizontal connection - OUTLET

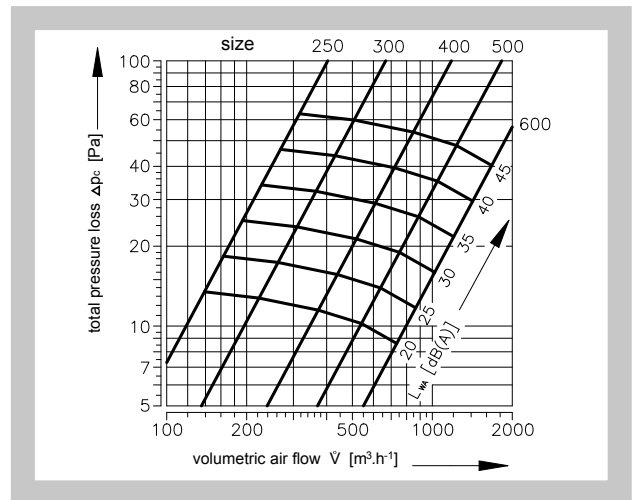

Diagram 7.2.3. ALKM - vertical connection - INLET

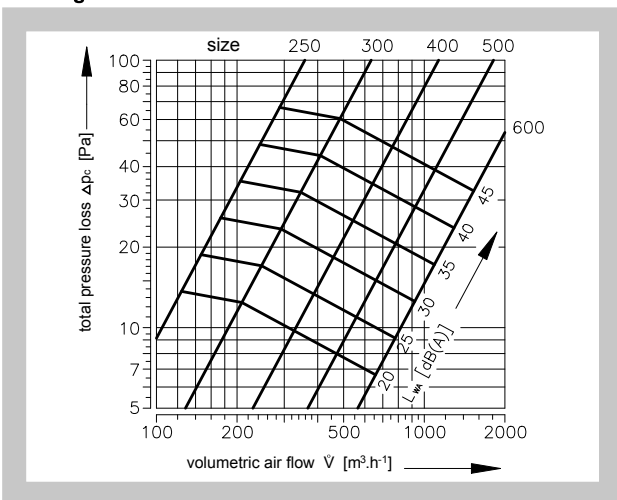
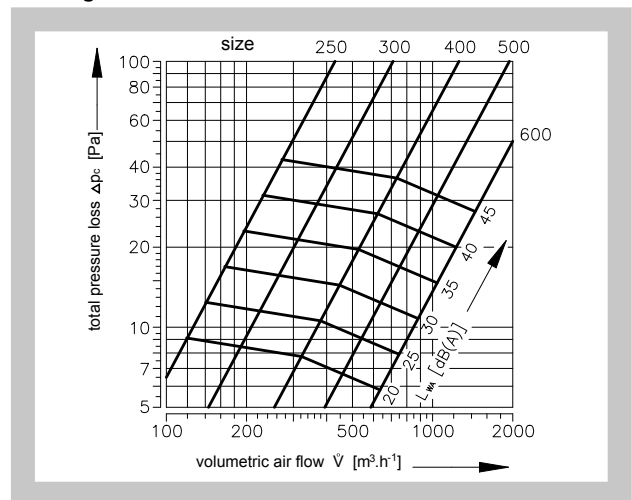

Diagram 7.2.4. ALKM - vertical connection - OUTLET



7.3. Corrective coefficients according to the angle of regulation flap valve adjustment

Tab. 7.3.1. Correction to chart 7.2.1. Adjustment of the adjusting flap

Size		Angle of flap adjustment		
		0°	45°	90°
250	Δp_c	x1,0	x1,3	x3,0
	L_{WA}	-	1	3
300	Δp_c	x1,0	x1,4	x3,4
	L_{WA}	-	1	3
400	Δp_c	x1,0	x1,5	x3,7
	L_{WA}	-	2	4
500	Δp_c	x1,0	x1,6	x3,8
	L_{WA}	-	3	6
600	Δp_c	x1,0	x1,6	x3,8
	L_{WA}	-	4	8

Tab. 7.3.2. Correction to chart 7.2.3. Adjustment of the adjusting flap

Size		Angle of flap adjustment		
		0°	45°	90°
250	Δp_c	x1,0	x1,2	x2,9
	L_{WA}	-	1	3
300	Δp_c	x1,0	x1,2	x3,0
	L_{WA}	-	1	3
400	Δp_c	x1,0	x1,3	x3,2
	L_{WA}	-	2	4
500	Δp_c	x1,0	x1,4	x3,5
	L_{WA}	-	2	5
600	Δp_c	x1,0	x1,5	x3,7
	L_{WA}	-	4	7

7.4. Temperature coefficient

Chart 7.4.1. Temperature coefficient

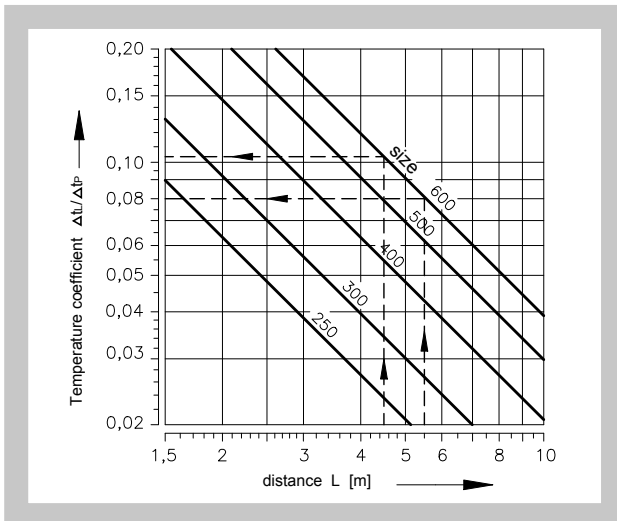

7.5. Velocity of airflow

Chart 7.5.1. Velocity of airflow - size 250

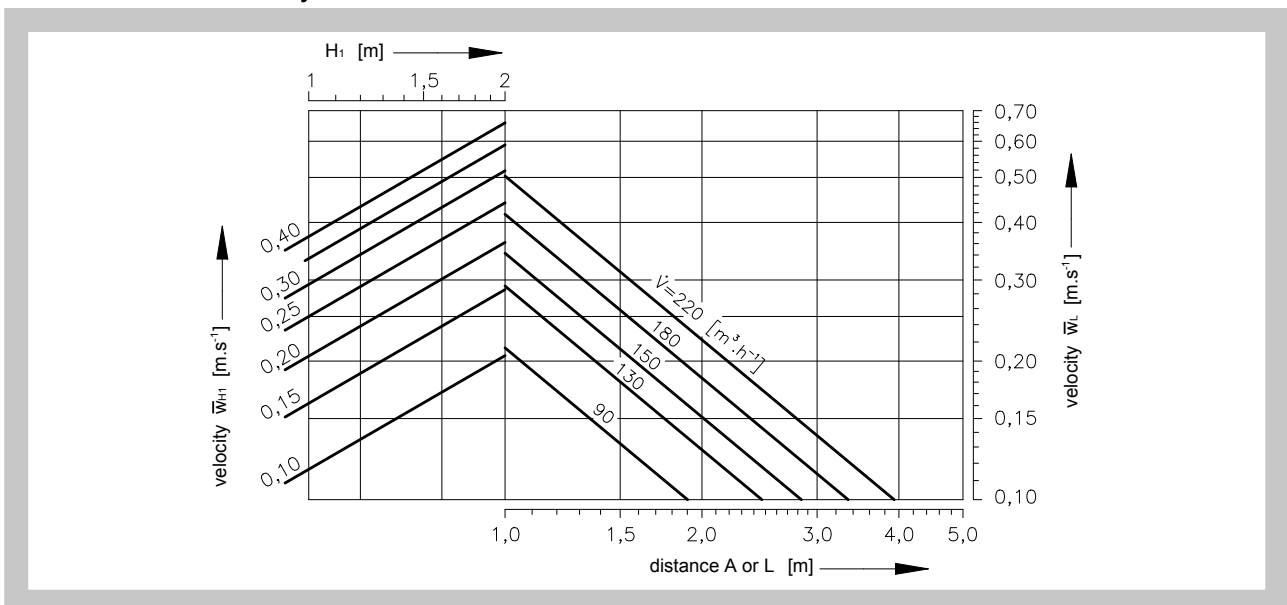

Chart 7.5.2. Velocity of airflow - size 300

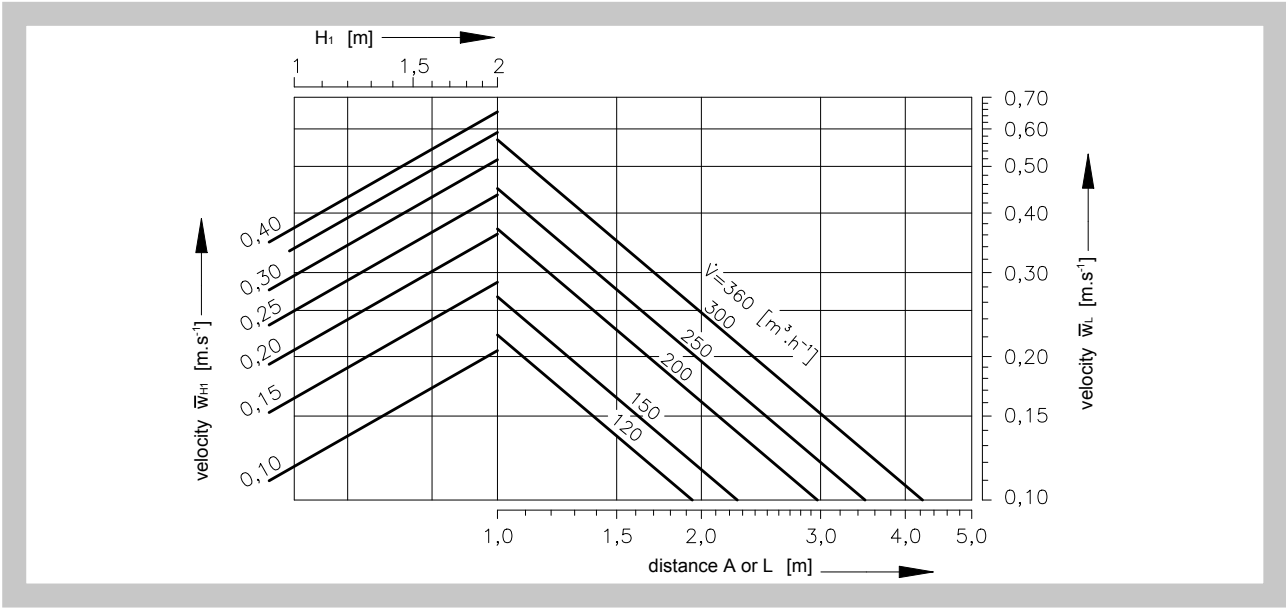

Chart 7.5.3. Velocity of airflow - size 400

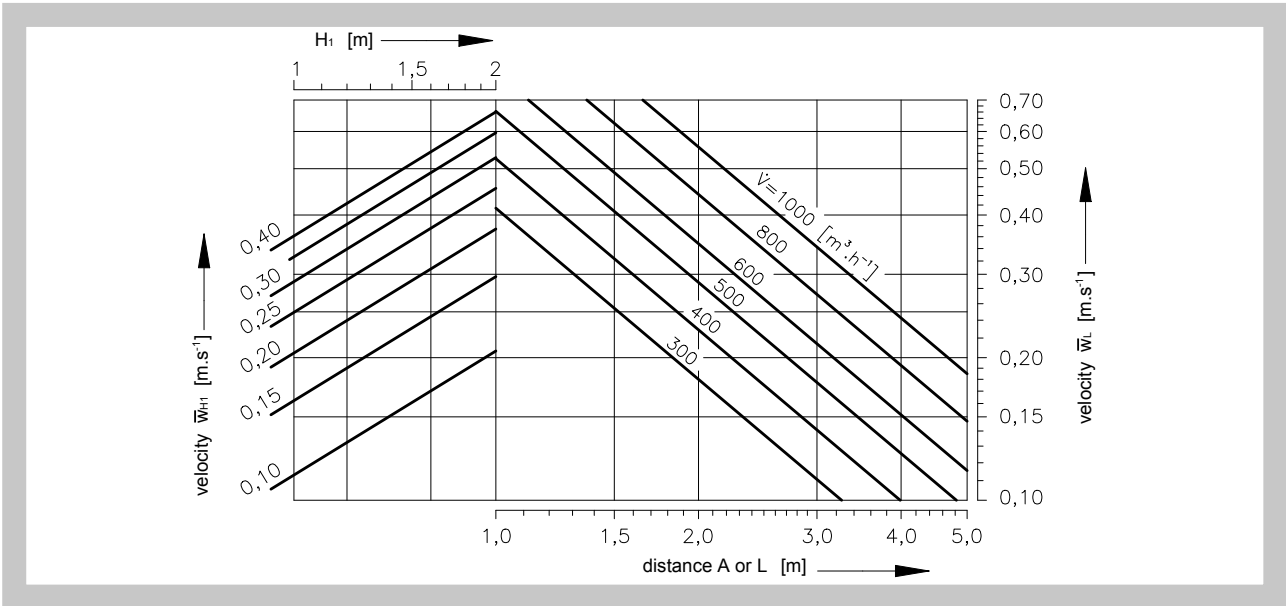

Chart 7.5.4. Velocity of airflow - size 500

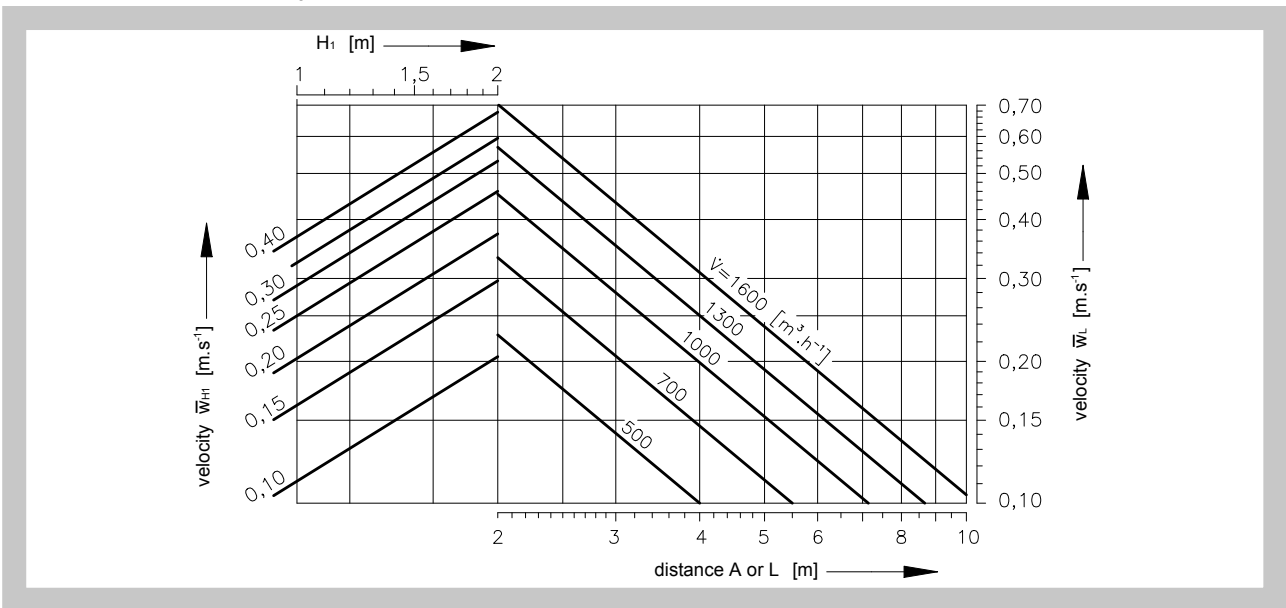

Chart 7.5.5. Velocity of airflow - size 600

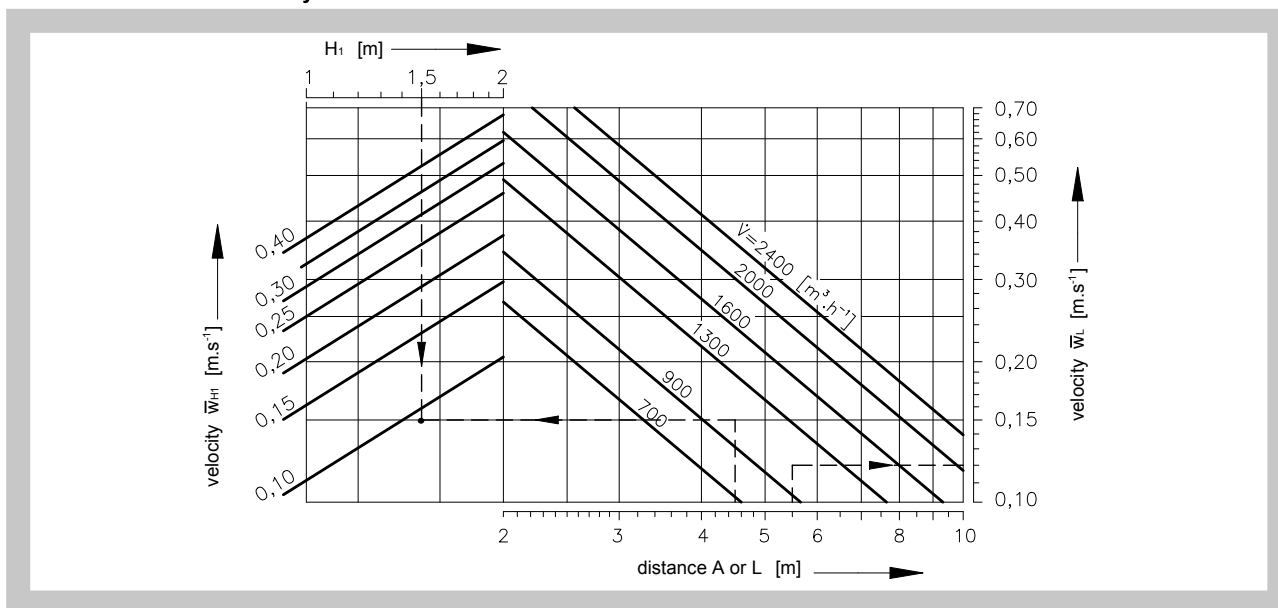

Fig. 9 Example:

Given data:

ALKM 600
 $\dot{V} = 1000 \text{ m}^3 \cdot \text{h}^{-1}$
 $\Delta t_p = -6 \text{ K}$
 $H_1 = 1,5 \text{ m}$
 $A = 6 \text{ m}$
 $X = 4,0 \text{ m}$
 $L = 5,5 \text{ m (to the wall)}$
 $L = 5,5 \text{ m (between anemostats)}$

Chart 7.2.1. :

$L_{WA} = 32 \text{ dB(A)}$
 $\Delta p_c = 17 \text{ Pa}$

Chart 7.4.1. :

$L = A/2 + H_1 = 4,5 \text{ m}$ between anemostats
 $\Delta t_L / \Delta t_p = 0,11$
 $\Delta t_L = -6 * 0,11 = -0,66 \text{ K}$
 $L = X + H_1 = 5,5 \text{ m}$ on the wall
 $\Delta t_L / \Delta t_p = 0,08$
 $\Delta t_L = -6 * 0,08 = -0,48 \text{ K}$

Chart 7.5.5. :

$\bar{w}_{H1} = 0,09 \text{ m} \cdot \text{s}^{-1}$ between anemostats
 $\bar{w}_L = 0,12 \text{ m} \cdot \text{s}^{-1}$ on the wall

IV. ORDERING INFORMATION

8. Ordering key

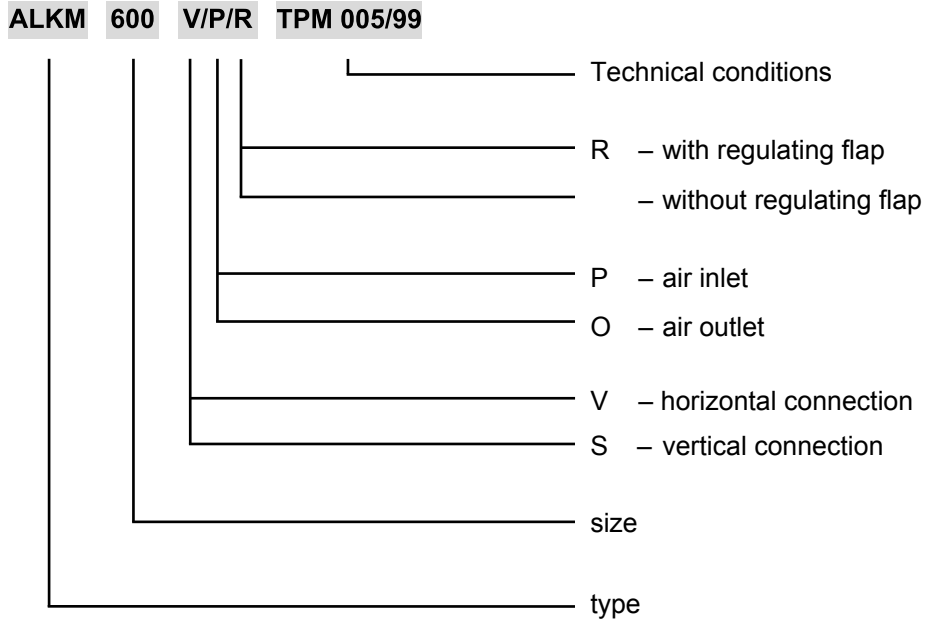

V. MATERIAL, FINISHING

9. Material

- 9.1. Face lamellas and frames are made of steel sheet. The surface is provided with white stove-enamel in shade RAL 9010. There is necessary to discuss the requirements for the other shade of face plates with the manufacturer.
- 9.2. The connection boxes are made of galvanized steel sheet.

VI. TRANSPORTATION AND STORAGE

10. Logistics terms

- 10.1. Anemostats are delivered in cardboard packaging. They are transported in bulk by common means of transport. If agreed with the customer, the outlets can be delivered on pallets. When handling during transport or storage, the outlets must be protected against mechanical damage and weather effects.
- 10.2. If not otherwise agreed, the handover is considered when the goods is forwarded to the carrier.
- 10.3. Anemostats must be stored in closed rooms, in environment without aggressive vapours, gases and dust. The temperature in the rooms must be maintained from -5 to +40°C and relative humidity max. 80%.

MANDÍK, a.s.
Dobříšská 550
26724 Hostomice
Czech Republic
Tel.: +420 311 706 706
E-Mail: mandik@mandik.cz
www.mandik.com

The producer reserves the right for innovations of the product. For actual product information see
www.mandik.com