

030/13 EN

VALID FROM: 23/4/19

MANDÍK[®]

INSTALLATION INSTRUCTIONS

FIRE DAMPER FDMD



FIRE damper type FDMD, is in all variants classified: as **EI 120 ve, ho (i↔o) S** or **EI 90 ve, ho (i↔o) S** acc. EN 13501-3 and tested acc. EN 1366-2 and acc. EN 15650.

Examples of installation (damper blade inside fire separating construction)

Installation in a solid wall construction

EIS 120

Legend:

- 1 Fire damper FDMD
- 2 Solid wall construction
- 3 Mortar or gypsum
- 4 Duct

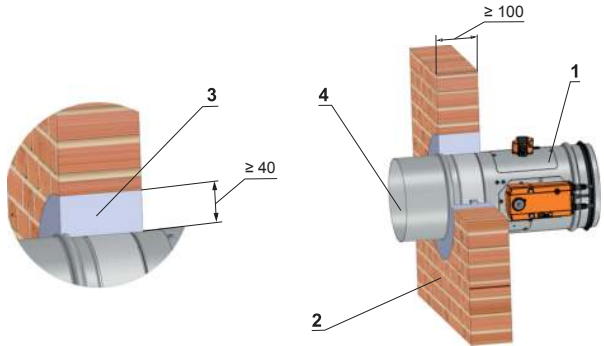

Installation in a solid wall construction

EIS 90

Legend:

- 1 Fire damper FDMD
- 2 Solid wall construction
- 3 Stuffing box (mineral stone wool min. density 140 kg/m³)
- 4 Fire protection mastic min. thickness 1 mm
- 5 Duct

Example materials used*:

- 3 Promapyr, Rockwool Steprock HD
- 4 Promastop - P, K

** Stuffing box and fire protection mastic can be replaced by another approved fire sealing system for damper installation with equivalent material properties.

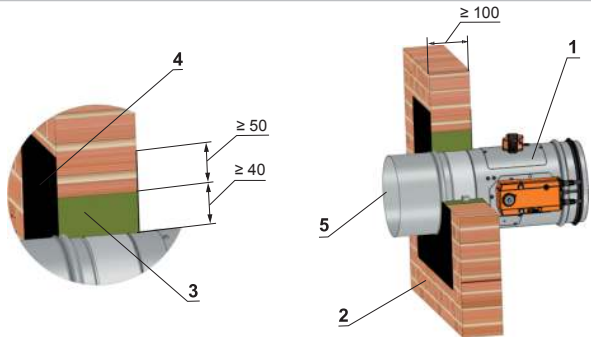

Installation in a solid wall construction (Weichschott system)

EIS 90

Legend:

- 1 Fire damper FDMD
- 2 Solid wall construction
- 3 Fire protection plate of mineral wool
- 4 Fire protection mastic min. thickness 1 mm
- 5 Duct

Example materials used:

- 3 Hilti CP673 PF
- 4 Hilti CP673

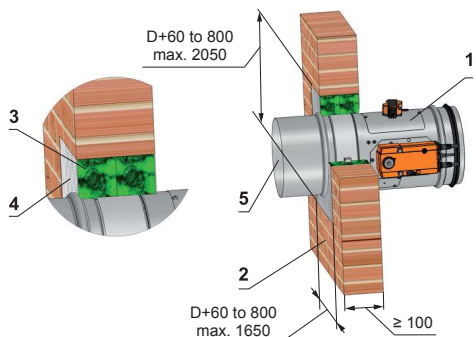

Installation in a gypsum wall construction

EIS 120

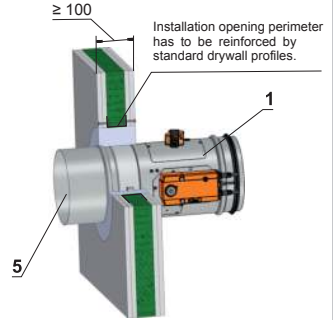
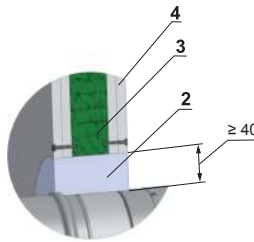

Legend:

- 1 Fire damper FDMD
- 2 Mortar or gypsum
- 3 Fire protection plate of mineral wool
- 4 Gypsum wall construction
- 5 Duct

Installation in a gypsum wall construction

EIS 90

Legend:

- 1 Fire damper FDMD
- 2 Gypsum wall construction
- 3 Fire protection plate of mineral wool
- 4 Stuffing box (mineral stone wool min. density 140 kg/m³)
- 5 Fire protection mastic min. thickness 1 mm
- 6 Duct

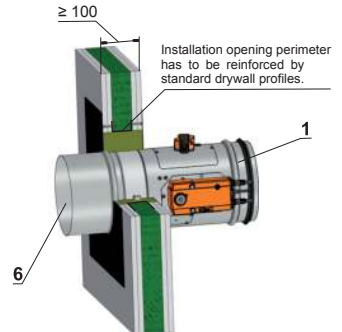
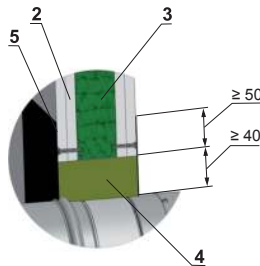

Example materials used*:

- 3 Promapyr, Rockwool Steprock HD
- 4 Promastop - P, K

** Stuffing box and fire protection mastic can be replaced by another approved fire sealing system for damper installation with equivalent material properties.

Installation in a gypsum wall construction (Weichschott system)

EIS 90

Legend:

- 1 Fire damper FDMD
- 2 Gypsum wall construction
- 3 Fire resistant board
- 4 Fire protection plate of mineral wool
- 5 Fire protection mastic min. thickness 1 mm
- 6 Duct

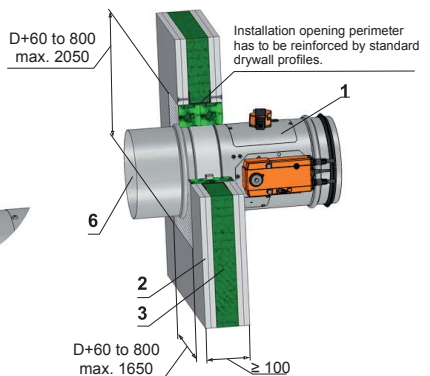
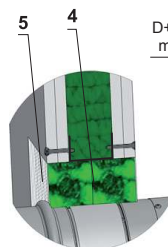

Example materials used:

- 3 Hilti CP673 PF
- 4 Hilti CP673

Installation in a solid ceiling construction

EIS 120

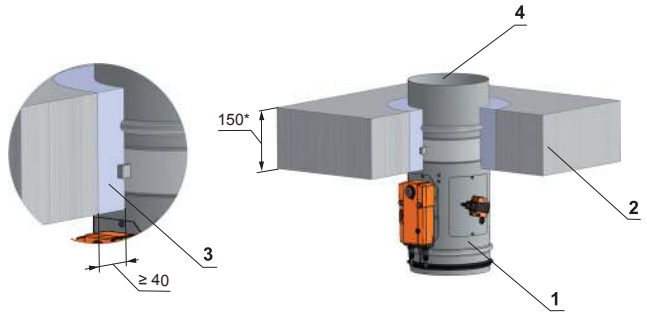

Legend:

- 1 Fire damper FDMD
- 2 Solid ceiling construction
- 3 Mortar or gypsum
- 4 Duct

* min. 110 - Concrete/ min. 125 - Aerated Concrete

Installation in a solid ceiling construction

EIS 90

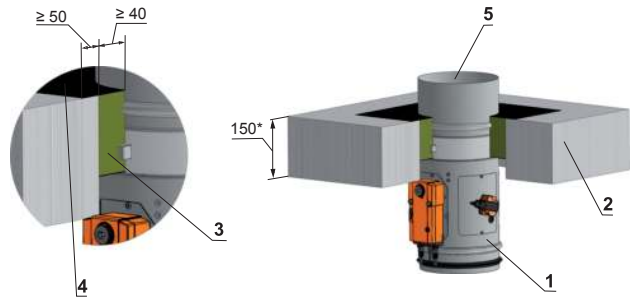

Legend:

- 1 Fire damper FDMD
- 2 Solid ceiling construction
- 3 Stuffing box (mineral stone wool min. density 140 kg/m³)
- 4 Fire protection mastic min. thickness 1 mm
- 5 Duct

Example materials used:**

- 3 Promapyr, Rockwool Steprock HD
- 4 Promastop - P, K

* min. 110 - Concrete/ min. 125 - Aerated Concrete

** Stuffing box and fire protection mastic can be replaced by another approved fire sealing system for damper installation with equivalent material properties.

Installation in a solid ceiling construction (Weichschott system)

EIS 90

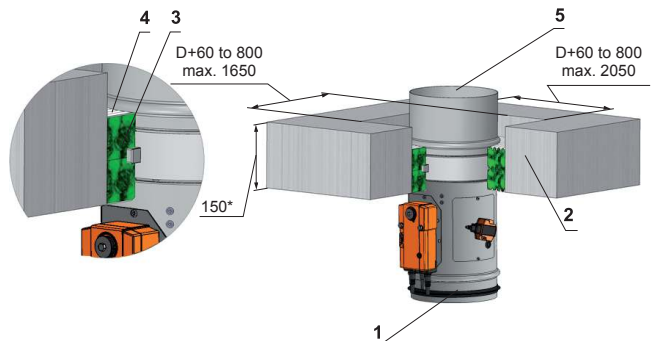

Legend:

- 1 Fire damper FDMD
- 2 Solid ceiling construction
- 3 Fire protection plate of mineral wool
- 4 Fire protection mastic min. thickness 1 mm
- 5 Duct

Example materials used:

- 3 Hilti CP673 PF
- 4 Hilti CP673

* min. 110 - Concrete/ min. 125 - Aerated Concrete

Another methods installation of fire dampers are available in TPM 092/13.

Examples of installation fire dampers in to the mounting frame in a solid wall construction

Installation frame D1, D2

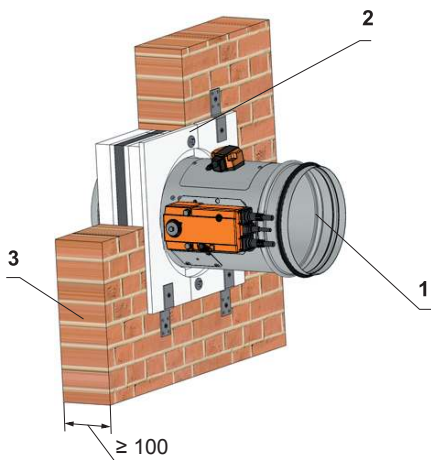

Installation frame D3, D4

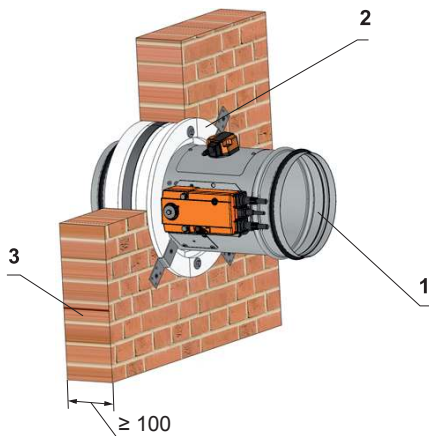

Installation frame D5

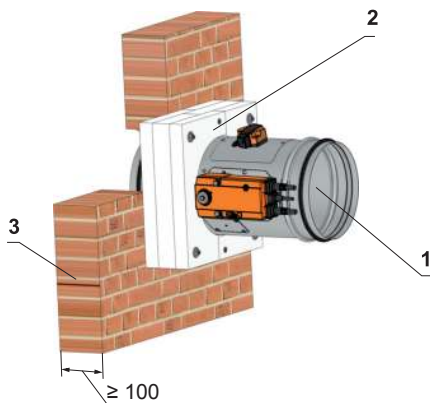

Legend:

- 1 Fire damper FDMD
- 2 Installation frame
- 3 Solid wall construction

Detailed description of installation using Installation frame is available in TPM 092/13.

Examples of installation fire dampers in to the mounting frame in a gypsum wall construction

Installation frame D1, D2

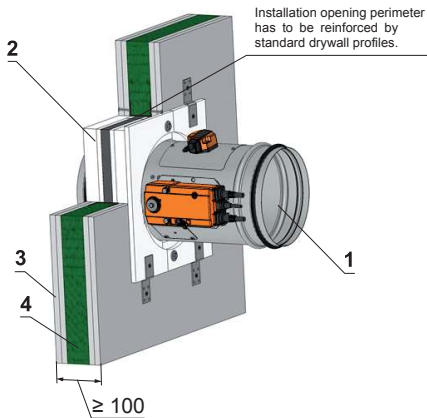

Installation frame D3, D4

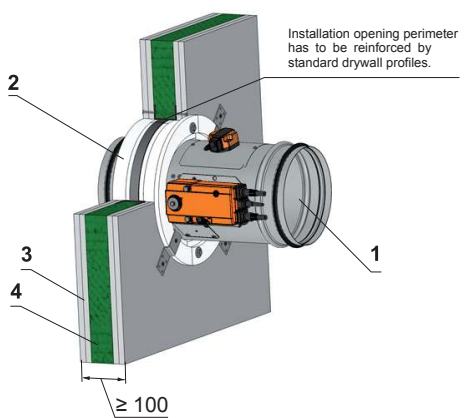

Installation frame D5

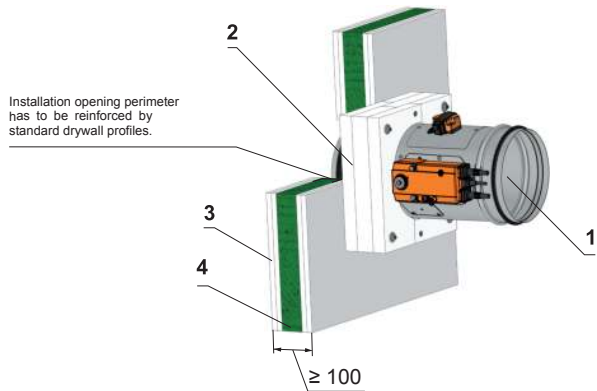

Legend:

- 1 Fire damper FDMD
- 2 Installation frame
- 3 Gypsum wall construction
- 4 Fire protection plate of mineral wool

Detailed description of installation using Installation frame is available in TPM 092/13.

Examples of installation fire dampers in to the mounting frame in a solid ceiling construction

Installation frame D1, D2

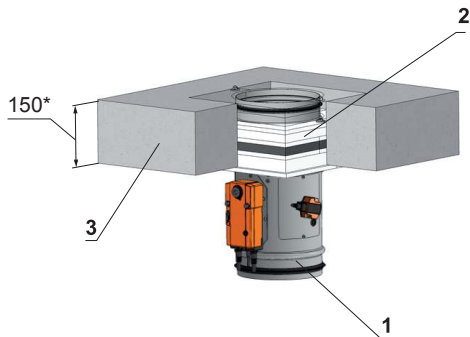

Installation frame D3, D4

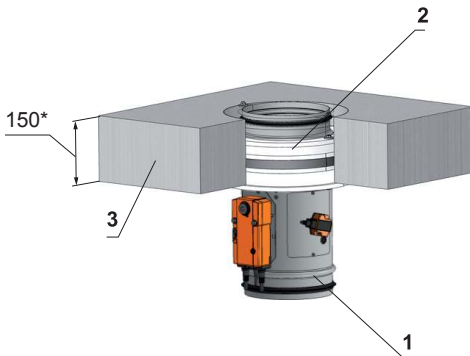

Installation frame D5

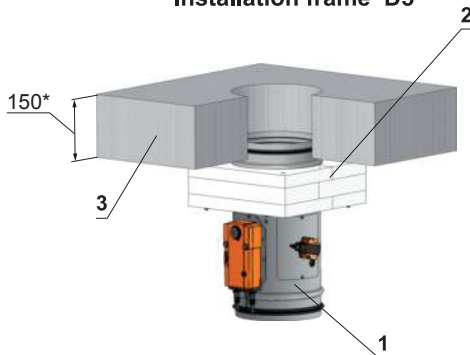

Legend:

- 1 Fire damper FDMD
- 2 Installation frame
- 3 Solid ceiling construction

* min. 110 - Concrete/ min. 125 - Aerated Concrete

Detailed description of installation using Installation frame is available in TPM 092/13.

Damper dimensions

FDMD with mechanical control

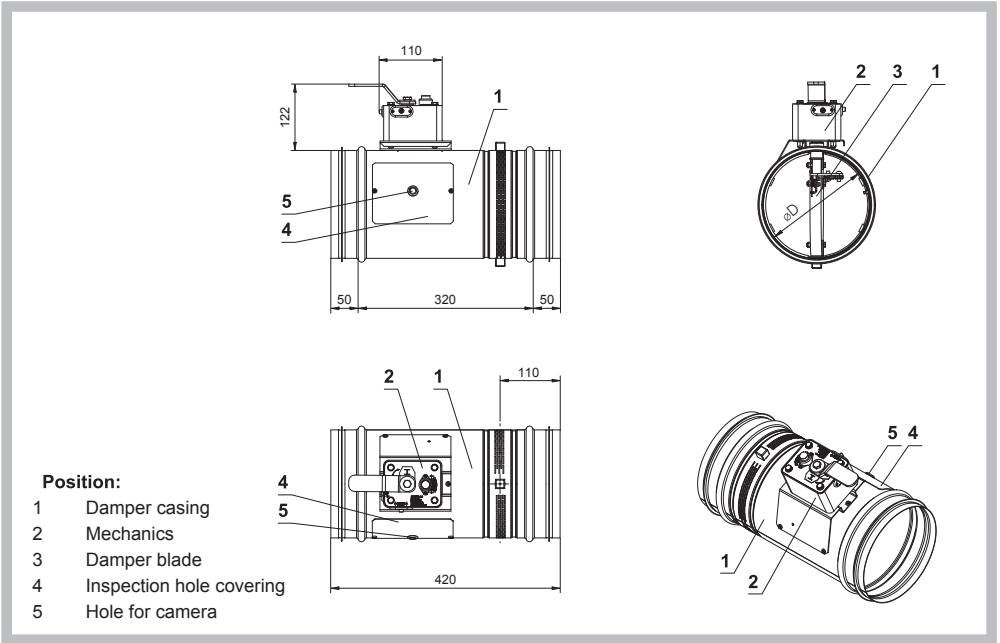

FDMD with actuating mechanism

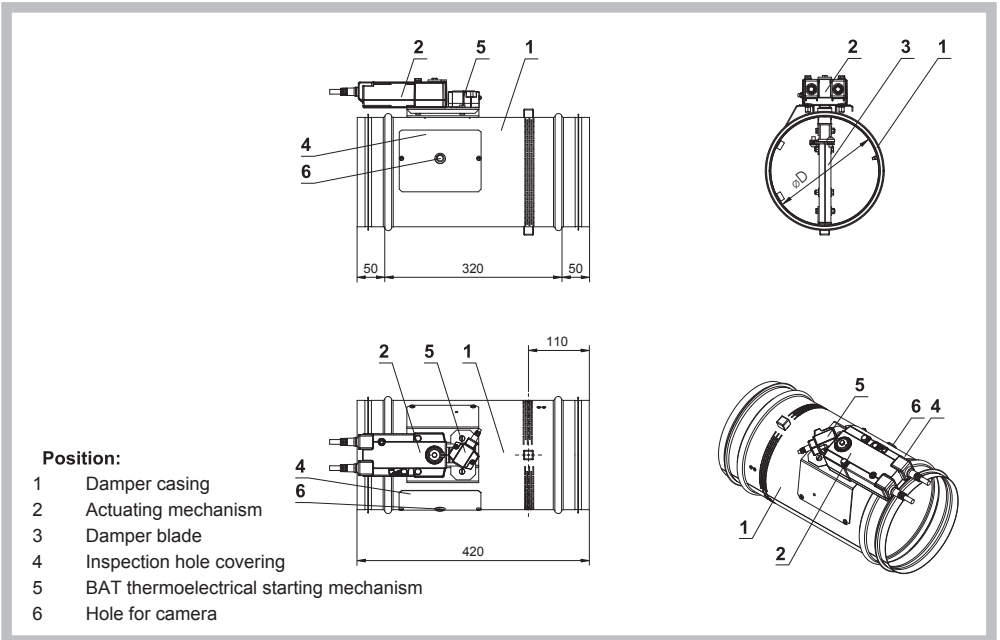

Installation instructions

- 1.) All fire dampers has to be closed during installation process.
- 2.) The control mechanism has to be protected (covered) against damage and pollution during installation process.
- 3.) Min. gap for installation (installation opening) is 25 mm (circular dimension $\varnothing D + 50$ mm).
- 4.) Installation gap must be filled by approved material perfectly in all the installation space volume (installation gap).
- 5.) The distance between the fire damper and the construction (wall, ceiling) must be minimum 75 mm according to EN 1366-2. In case that two or more dampers are supposed to be installed in one fire separating construction, the distance between the adjacent dampers must be at least 200 mm according to EN 1366-2 paragraph 13.5.
- 6.) Installation openings.

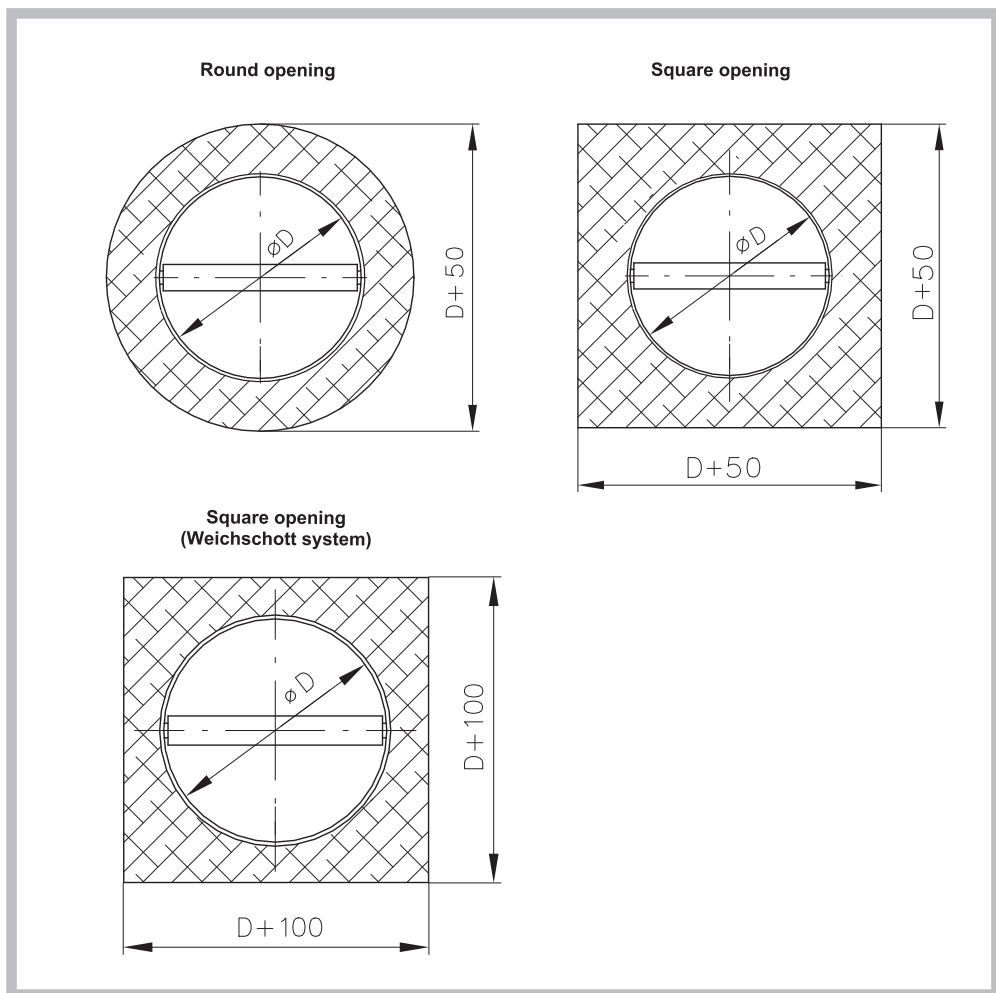

7.) Placement of the openings in the wall.

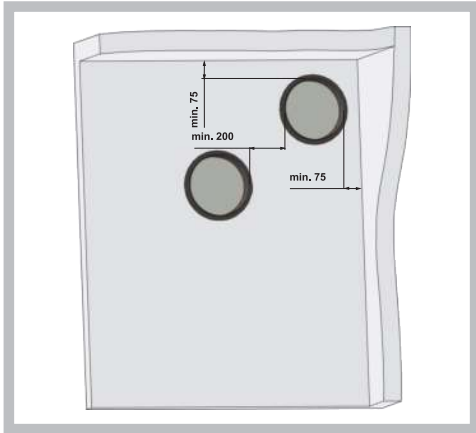

NOTICE

Damper assembly procedures must be done so as all load transfer from the fire separating constructions to the damper body is absolutely excluded. Back-to-back air - conditioning piping must be hung or supported so as all load transfer from the back-to-back piping to the damper is absolutely excluded.

8. The fire damper can be integrated into a solid or gypsum wall construction or into solid ceiling construction. Damper blade has to be inside of construction (labelled with BUILT IN EDGE on the damper body).

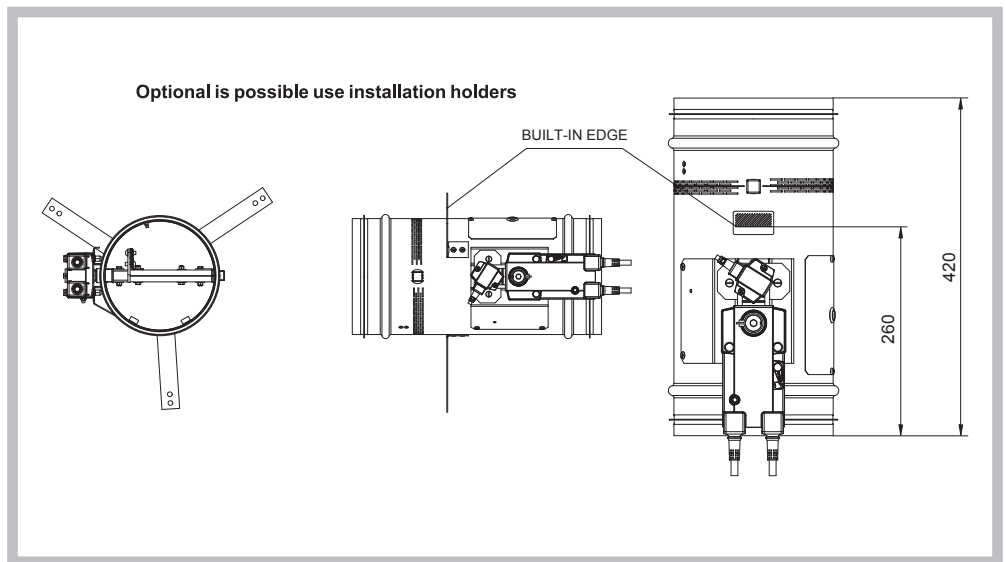

9. All fire dampers has to be closed during installation process. The damper body should not be deformed in the course of bricking in. Once the damper is built in, its blade should not grind on the damper body during opening or closing.
10. To provide needed access space to the control device, all other objects must be situated at least 350 mm from the control parts of the damper. Inspection hole must be accessible.
11. Electrical components, wiring diagrams.

Actuating mechanism BELIMO BLF 24-T(-ST)

AC/DC 24

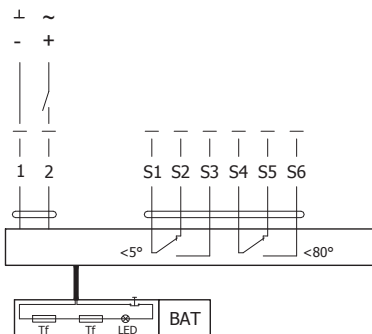

Actuating mechanism BELIMO BLF 230-T

AC230 V

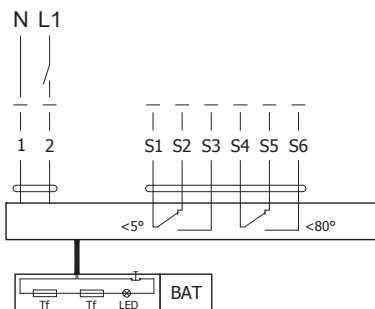

12. Before entering the dampers into operation after assembly and after sequential revisions, checks and functionality tests of all designs including operation of the electrical components must be done. After entering into operation, these revisions must be done according to requirement set by national regulations.
13. Before entering the dampers into operation after their assembly and by sequential checks, the following checks must be carried out.

Visual inspection of proper damper integration, inside damper area, damper blade, contact surfaces and silicon sealing.

Inspection hole disassembly: release the covering lid by removing the two screws in the corners of inspection hole. Then remove lid from its original position.

14. Before entering the dampers with manual control into operation after their assembly and by sequential checks, checks according 13. and following checks must be carried out.

Check of thermal protective fuse and closing mechanism.

Push initiation lever lock "OPEN" to release the control lever and check its displacement into the position "CLOSED". Closing must be smart and the control lever must be firmly locked with a lever lock "CLOSED". In case that the closing is not smart enough and the control lever is not locked with the lever lock in the position "CLOSED", higher pre-stretch of the closing spring must be set by using new hole in base plate or using new spring.

Proper function of the thermal fuse can be checked when the fuse is removed from the starting mechanism. The initiation lever must be turned over and control lever is moved to position "CLOSED". If this is not possible, then the starting mechanism spring must be checked or the base plate must be replaced. The base plate is attached to the damper body with four M5 screws.

Displacing the damper blade into "OPEN" position is done the following way:

Push lever lock "CLOSED" and move control lever from "CLOSED" position towards position "OPEN" until control lever is locked in lever lock "OPEN".

15. Before entering the dampers with actuating mechanism into operation after their assembly and by sequential checks, checks according 13. and following checks must be carried out.

Check of blade displacement into the breakdown position "CLOSED" can be done after cutting off the actuating mechanism supply (e.g. by pressing the RESET button at the thermoelectrical starting mechanism BAT or cutting off the supply from ELECTRICAL FIRE SIGNALISATION). Check of blade displacement back into the "OPEN" position can be done after restoration of power supply (e.g. By releasing the RESET button or restoration of supply from ELECTRICAL FIRE SIGNALISATION).

16. Manual operation

Without power supply, the damper can be operated manually and fixed in any required position. Release of the locking mechanism can be achieved manually or automatically by applying the supply voltage.

17. It is recommended to provide periodical checks, maintenance and service actions on Fire Equipment by Authorized persons schooled by Producer.

18. All effective safety standards and directives must be observed during fire damper assembly.

Material

1. Damper bodies are supplied in the standard design made of galvanized plate without any other surface finish.
2. Damper blades are made of fire resistant asbestos free boards made of mineral fibres.
3. Damper controls are made of galvanized materials with no other surface finish.
4. Springs are galvanized.
5. Thermal protective fuses are made of sheet brass, thickness = 0.5 mm.
6. Fasteners is galvanized.

Comment

Comment

MANDÍK, a.s.
Dobříšská 550
26724 Hostomice
Czech Republic
Tel.: +420 311 706 706
e-mail: mandik@mandik.cz
www.mandik.com
