

**MANDÍK<sup>®</sup>**

**INSTALLATION INSTRUCTIONS**

**FIRE DAMPER WITH  
INSTALLATION FRAME E1-E6  
FDMB-S**

## Installation instructions

### Fire damper FDMB-S with installation frame E1

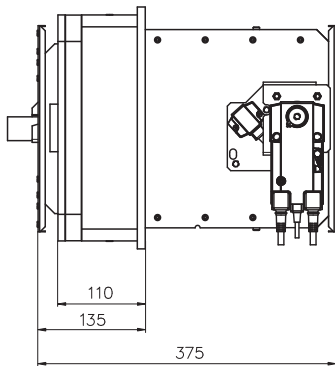

#### Packaging:

Description	Number
Fire damper FDMB-S	1
Installation frame E1	1
Holder	X
Screw 4x50 mm	Y

#### Installation opening:

$$a \times b = (A + 105^{+3} \text{ mm}) \times (B + 105^{+3} \text{ mm})$$

$$X = (2 \times ZB) + (2 \times ZH)$$

$$Y = 2 \times X$$

#### Solid wall construction

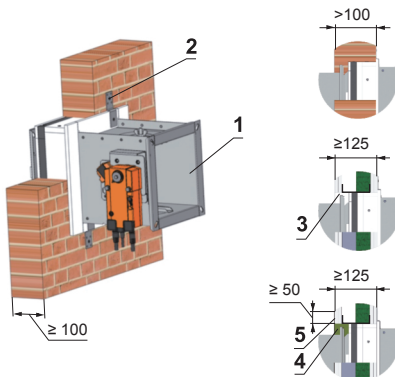

#### Gypsum wall construction

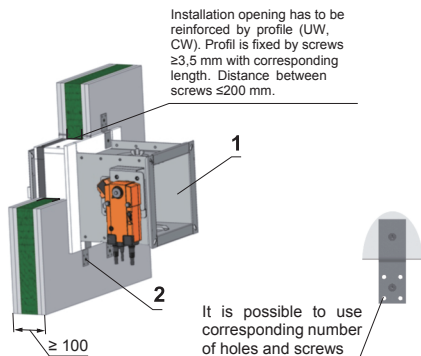

#### Solid ceiling construction

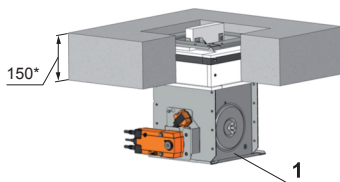

\* min. 110 - Concrete/ min. 125 - Aerated concrete

Holders No.  $X = (2 \times ZB) + (2 \times ZH)$   
Screws No.  $Y = 2 \times X$

Dimensions	Number ZB1	Number ZH1
$A, B \leq 400$	1	1
$400 < A, B \leq 800$	2	2
$800 < A \leq 1000$	3	3

#### POSITION:

- 1 Fire damper FDMB-S with Installation frame E1
- 2 Holder with screws
- 3 Gypsum plate
- 4 Mineral stone wool min. density  $140 \text{ kg/m}^3$
- 5 Fire protection mastic min. thickness 1 mm

**Notice:** Gap between frame end damper body and frame and solid (gypsum) wall construction must be filled by glue (PROMAT K84). Dampers has to be suspended in an appropriate manner see TPM 075/09, chapter 8.

## Installation instructions

### Fire damper FDMB-S with installation frame E2

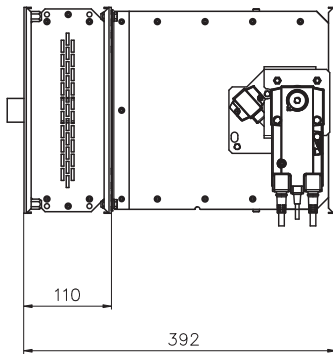

#### Packaging:

Description	Number
Fire damper FDMB-S	1
Installation frame E2	1
Screw M6x16 mm	X
Washer 6,4 mm	X

#### Installation opening:

$$a \times b = (A + 100^{+3} \text{ mm}) \times (B + 100^{+3} \text{ mm})$$

$$X = (2 \times ZB) + (2 \times ZH - 4)$$

#### Solid wall construction

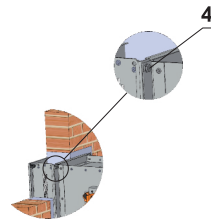
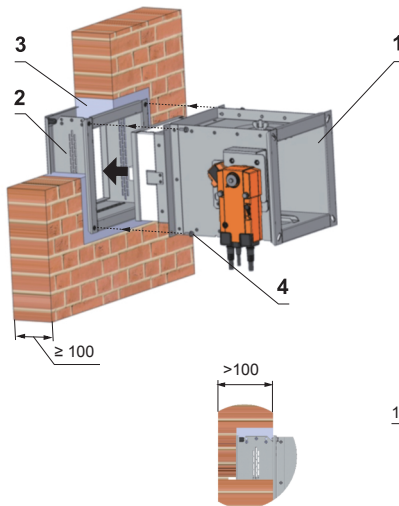

#### Solid ceiling construction

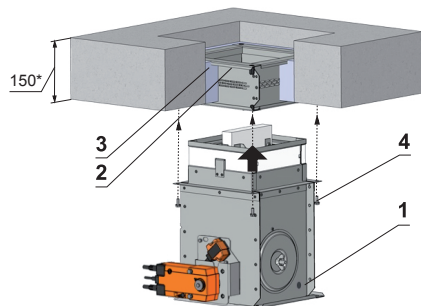

#### POSITION:

- 1 Fire damper FDMB-S
- 2 Installation frame E2
- 3 Mortar or gypsum
- 4 Holder with screws

\* min. 110 - Concrete/ min. 125 - Aerated concrete

**Notice:** Dampers has to be suspended in an appropriate manner see TPM 075/09, chapter 8.

**Installation instructions**

**Fire damper FDMB-S with installation frame E3**

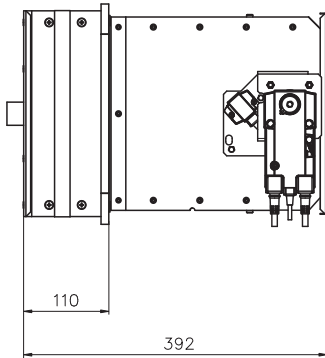

**Packaging:**

Description	Number
Fire damper FDMB-S	1
Installation frame E3	1
Screw 5x30 mm	X

**Installation opening:**

$$a \times b = (A + 67^{+3} \text{ mm}) \times (B + 67^{+3} \text{ mm})$$

$$X = (2 \times ZB) + (2 \times ZH - 4)$$

**Gypsum wall construction**

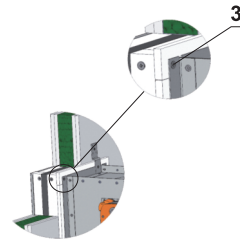
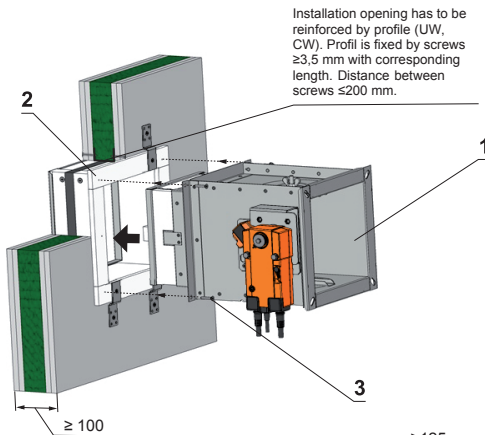

It is possible to use corresponding number of holes and screws.

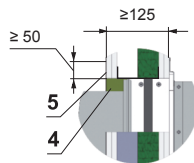

**POSITION:**

- 1 Fire damper FDMB-S
- 2 Installation frame E3
- 3 Screw
- 4 Mineral stone wool min. density 140 kg/m<sup>3</sup>
- 5 Fire protection mastic min. thickness 1 mm

Holders No. X = (2xZB) + (2xZH)  
Screws No. Y = 2xX

Dimensions	Number ZB1	Number ZH1
A, B ≤ 400	1	1
400 < A, B ≤ 800	2	2
800 < A ≤ 1000	3	3

**Notice:** Gap between frame end damper body and frame and solid (gypsum) wall construction must be filled by glue (PROMAT K84). Dampers has to be suspended in an appropriate manner see TPM 075/09, chapter 8.

## Installation instructions

### Fire damper FDMB-S with installation frame E4

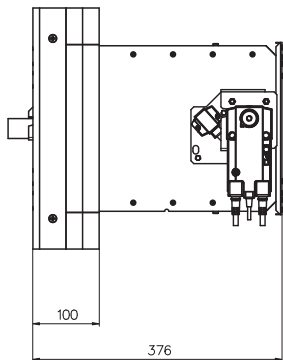

**Packaging:**

Description	Number
Fire damper FDMB-S	1
Installation frame E4	1

**Installation opening:**

$a \times b = (A + 5^{+3} \text{ mm}) \times (B + 5^{+3} \text{ mm})$

$a \times b = (A + 100^{+3} \text{ mm}) \times (B + 100^{+3} \text{ mm})^*$

\*installation with concrete

**On solid wall construction**

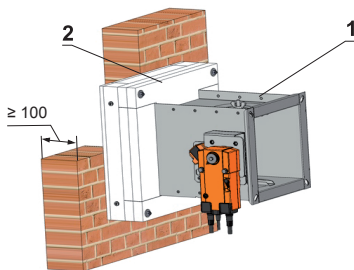

**On gypsum wall construction**

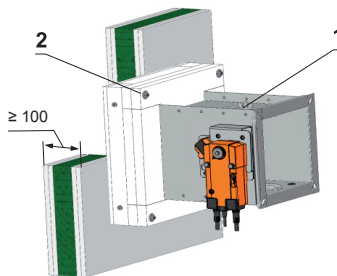

**Outside solid ceiling, concrete and installation frame**

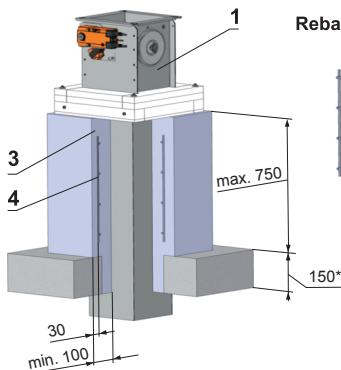

Rebar - Steel wire O 6 mm

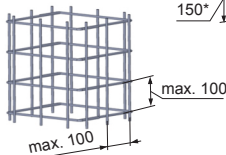

**On ceiling wall construction**

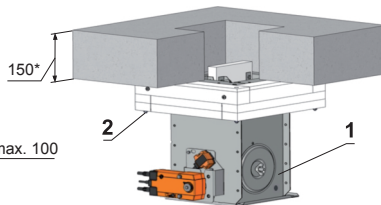

**POSITION:**

- 1 Fire damper FDMB-S with installation frame E4
- 2 Fitting with threaded rods or steel bracket
- 3 Concrete B20
- 4 Rebar

\* min. 110 - Concrete/ min. 125 - Aerated concrete

**Notice:** Dampers has to be suspended in an appropriate manner see TPM 075/09, chapter 8.

**Installation instructions**

**Fire damper FDMB-S with installation frame E5**

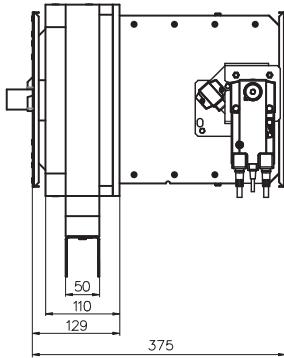

**Packaging:**

Description	Number
Fire damper FDMB-S	1
Installation frame E5	1

**Installation:**

- Directly on the ceiling
  - In distance from ceiling max. 80 mm
- X = Ceiling movement (max. 40 mm)  
 Y = Distance of movement (max. 80 mm)

**Gypsum wall construction with ceiling movement possibility**

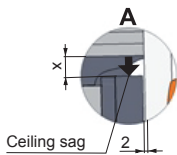

**Directly on the ceiling**

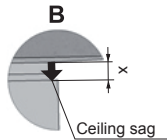

**In distance "y" with filling**

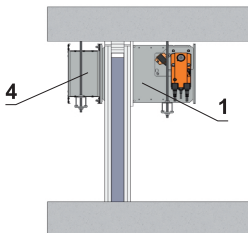
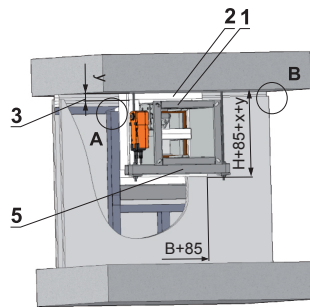
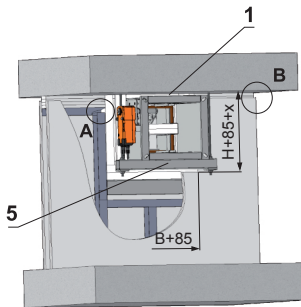

**POSITION:**

- 1 Fire damper FDMB-S with installation frame E5
- 2 Cement lime filling min. density  $450 \text{ kg/m}^3$
- 3 Ceiling movement: construction thickness 100 mm
- 4 Extension part
- 5 Suspension

**Notice:** Fitting with threaded rods or steel bracket

## Installation instructions

### Fire damper FDMB-S with installation frame E6

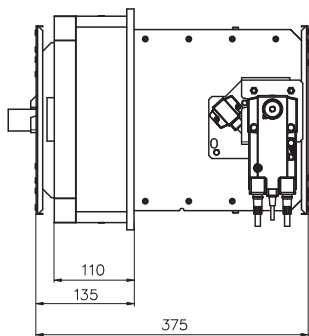

#### Packaging:

Description	Number
Fire damper FDMB-S	1
Installation frame E6	1

#### Installation opening:

$$a \times b = (A + 105^{+3} \text{ mm}) \times (B + 105^{+3} \text{ mm})$$

#### Outside solid wall

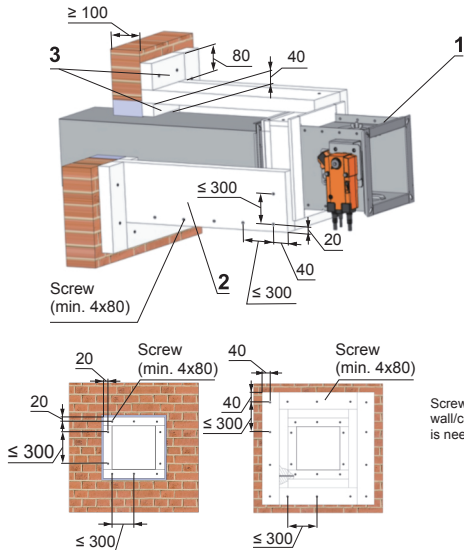

#### POSITION:

- 1 Damper with installation frame E6
- 2 Cement lime plates min. thickness 40 mm (min. density 450 kg/m<sup>3</sup>)
- 3 Cement lime prisms min. thickness 40 mm (min. density 450 kg/m<sup>3</sup>)

#### Outside solid ceiling

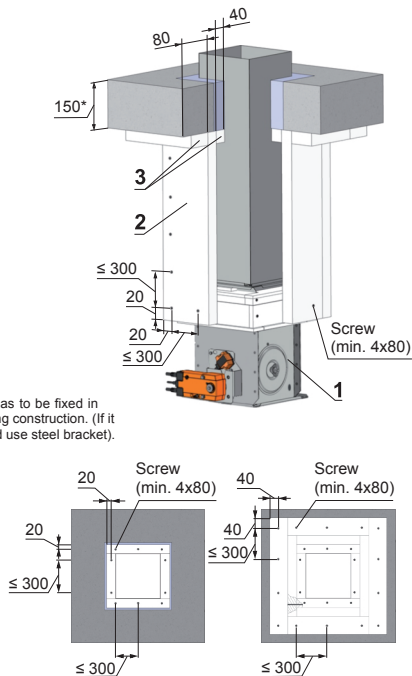

Screws has to be fixed in wall/ceiling construction. (If it is needed use steel bracket).

\* min. 110 - Concrete/ min. 125 - Aerated concrete

**Notice:** All parts are glued with glue Promat K84 and secured by screws.  
Dampers has to be suspended in an appropriate manner see chapter 8.

MANDÍK, a.s.  
Dobříšská 550  
26724 Hostomice  
Czech Republic  
Tel.: +420 311 706 706  
E-Mail: [mandik@mandik.cz](mailto:mandik@mandik.cz)  
[www.mandik.com](http://www.mandik.com)