

FDML

Multi blade fire damper

Technical Documentation

Installation, Commissioning, Operation, Maintenance and Service Manual



These technical specifications state a row of manufactured sizes and models of fire dampers FDML
It is valid for production, designing, ordering, delivery, maintenance and operation.

CONTENT

I. GENERAL.....	3
Description.....	3
II. DESIGN.....	4
Design with spring return actuator.....	4
III. DIMENSIONS.....	11
Technical parameters.....	12
IV. INSTALLATION.....	16
Placement and installation.....	16
Statement of installations.....	17
In solid wall construction.....	18
In gypsum wall construction.....	20
In solid ceiling construction.....	22
Examples of installation situations.....	23
Examples of fixing FDML.....	24
Example of duct connection.....	27
V. TECHNICAL DATA.....	28
Pressure loss.....	28
VI. MATERIAL, FINISHING.....	30
VII. TRANSPORTATION, STORAGE AND WARRANTY.....	30
Logistic terms.....	30
Warranty.....	30
VIII. ASSEMBLY, ATTENDANCE AND MAINTENANCE.....	31
Commissioning and revisions.....	32
IX. ORDERING INFORMATIONS.....	33
Ordering key.....	33
Data label.....	33

I. GENERAL

Description

Fire dampers are shutters in ducts of air-conditioning devices that prevent the spread of fire and combustion products from one fire segment to the other one. FDML multi blade fire dampers are in motorised design only with actuator and they have the following two main applications:

For use as a fire shutter without following air duct with cover grilles for closing ventilation openings in fire separating walls, constructions, elevator and other shafts, cable and other ducts, preventing the spread of heat and combustion products.

For use as a multi blade fire damper with following air duct on both sides (without cover grilles) or with duct on one side (with one cover grille), preventing the spread of heat and combustion products through this duct system.

Damper blades automatically closes air duct using a spring return actuator. The return spring of the actuator is actuated when a thermoelectric activation device BAT is activated, when a test button on BAT is pressed or when power supply of the actuator is interrupted.

After closing blades, the damper is sealed with silicon against smoke penetration. On request by customer, the damper can be supplied silicon-free. In the closed position, the damper is also sealed with material which increases its volume due to increasing temperature and air proofs the air duct.

Damper characteristics

- CE certified acc. to EN 15650
- Tested in accordance with EN 1366-2
- Classified acc. to EN 13501-3+A1
- Fire resistance EI 90 S, E 120 S
- Leakage acc. to EN 1751, through the casing class ATC 4 (old marking "B") and through the damper blades class 3
- Cycling tests in class C₁₀₀₀ acc. to EN 15650
- Corrosion resistant acc. to EN 15650
- Certificate of constancy of performance No. 1391-CPR-XXXX/XXXX
- Declaration of Performance No. PM/FDML/01/XX/X
- Hygienic assessment of fire dampers - Report No. 1.6/pos/19/19b

Working conditions

- Exact damper function is provided under the following conditions:
 - maximum air velocity 12 m/s
 - maximum pressure difference 1500 Pa
 - Even distribution of air flow in complete damper cross section area
- Damper operating characteristics are independent on airflow direction through the damper. The damper can be installed with blade axis vertically or horizontally, temperature sensor (BAT) must always be in damper upper part.
- Dampers are suitable for systems without abrasive, chemical and adhesive particles.
- Dampers are designed for macroclimatic areas with mild climate according to EN IEC 60 721-3-3 ed.2., class 3K22. (Environment 3K22 is typically protected place with regulated temperature).
- Temperature in the place of installation is permitted to range from -30°C to +50°C.
- Optical smoke detector ORS 142K with socket 143A is intended for environments protected from weathering of categories 3K5/3Z1/3Z8/3B1/3C2/3S1/3M2 within temperature scope -25°C to +70°C, max. relative humidity 95% at 40°C, without condensing, icing and ice formation according to EN 60 721-3-3 amend.A2.
- If the damper is used for self-ventilation it must be equipped with cover grilles from both sides.



II. DESIGN

Design with spring return actuator

Design .40 and .50

- Fire dampers are equipped with Belimo spring return actuators with thermoelectric activation device BAT. The spring return actuator types are BFL, BFN or BF depending on the damper size. (Further mentioned as „actuator“).
- After being connected to power supply 230V or AC/DC 24V, the actuator rotates the damper blades to the operating position "OPEN" and at the same time prestretches its return spring. When the actuator is power supplied, the damper blades are in the position "OPEN" and the return spring is prestretched. Time needed for full opening of the damper blades from the position "CLOSED" to the position "OPEN" is maximum 120 sec.
- If the actuator power supply is interrupted (due to loss of supply voltage, or pressing a test button on the thermoelectric activation device BAT), the actuator rotates the damper blades to the breakdown position "CLOSED". The time of closing the damper blades from the position "OPEN" to the position "CLOSED" takes maximum 20 sec.
- In case that the power supply is restored again (the blades can be in any position), the actuator starts to rotate the damper blades back to the position "OPEN".
- A thermoelectric activation device BAT, which contains two thermal fuses Tf1 and Tf2, is an integral part of the actuator.
- These fuses are activated when temperature +72°C has been reached (the fuse Tf1 due to temperature outside the duct and the fuse Tf2 due to temperature inside the duct). The thermoelectric activation device can also be equipped with a Tf2 thermal fuse type ZBAT 95/120/140 (must be specified in the order). In this case, the activation temperature inside the duct is +95°C, +120°C or +140°C (depending on the type).
- After the thermal fuse Tf1 or Tf2 has been activated, the power supply is permanently and irreversibly interrupted and the actuator, by means of the pre-stretched spring, rotate the damper blades into the breakdown position "CLOSED".
- Signalisation of damper blades position "OPEN" and "CLOSE" is provided by two microswitches.

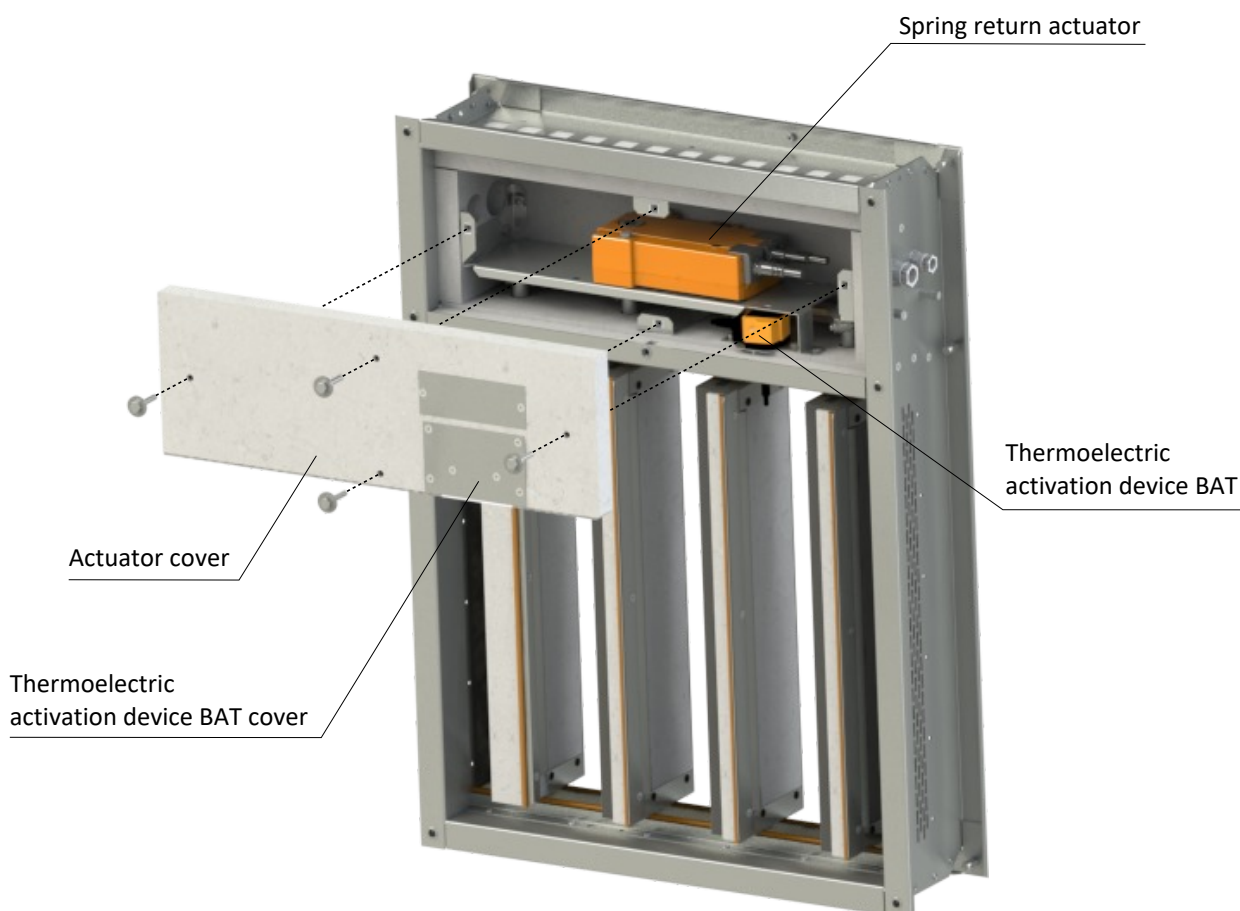

Actuator BELIMO BFL 230-T(-ST)

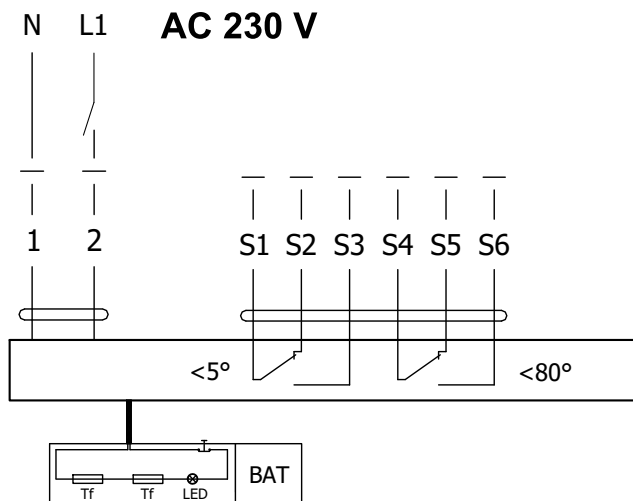

Actuator BELIMO BFL 24-T(-ST)

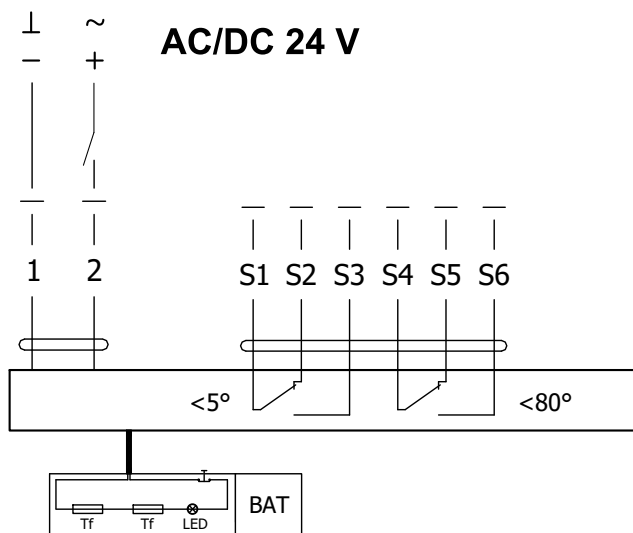

Actuator BELIMO BFL 230-T(-ST), BFL 24-T(-ST)

Actuator BELIMO - 4 Nm/ 3 Nm Spring	BFL 230-T(-ST)	BFL 24-T(-ST)
Power voltage	AC 230 V 50/60Hz	AC/DC 24 V 50/60Hz
Power consumption - in operation - in rest position	3,5 W 1,1 W	2,5 W 0,8 W
Dimensioning	6,5 VA (Imax 4 A @ 5 ms)	4 VA (Imax 8,3 A @ 5 ms)
Protection class	II	III
Degree of protection	IP 54	
Running time - motor - spring return	< 60 s ~ 20 s	
Ambient temperature - normal duty - safety duty - non-operating temperature	-30°C ... +55°C The safe position will be attained up to max. +75°C -40°C ... +55°C	
Connection - supply/control - auxiliary switch	cable 1 m, 2 x 0,75 mm ² (BFL 2xx-T-ST) with 3-pin plug-in connectors cable 1 m, 6 x 0,75 mm ² (BFL 2xx-T-ST) with 6-pin plug-in connectors	
Response temperature thermal fuse	duct outside temperature +72°C duct inside temperature +72°C	

Actuator BELIMO BFN 230-T(-ST)

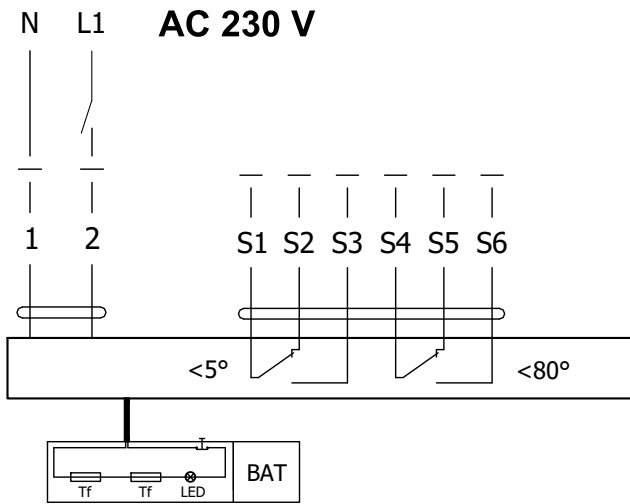

Actuator BELIMO BFN 24-T(-ST)

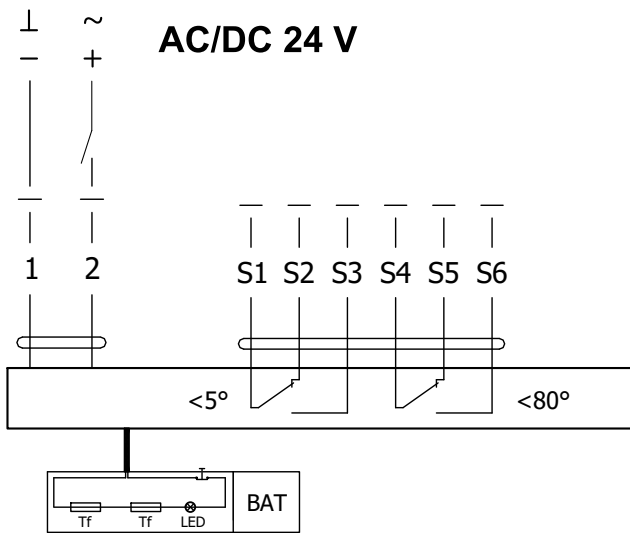

Actuator BELIMO BFN 230-T(-ST), BFN 24-T(-ST)

Actuator BELIMO - 9 Nm/ 7 Nm Spring	BFN 230-T(-ST)	BFN 24-T(-ST)
Power voltage	AC 230 V 50/60Hz	AC/DC 24 V 50/60Hz
Power consumption - in operation - in rest position	5 W 2,1 W	4 W 1,4 W
Dimensioning	10 VA (I _{max} 4 A @ 5 ms)	6 VA (I _{max} 8,3 A @ 5 ms)
Protection class	II	III
Degree of protection	IP 54	
Running time - motor - spring return	< 60 s ~ 20 s	
Ambient temperature - normal duty - safety duty - non-operating temperature	-30°C ... +55°C The safe position will be attained up to max. +75°C -40°C ... +55°C	
Connection - supply/control - auxiliary switch	cable 1 m, 2 x 0,75 mm ² (BFN 2xx-T-ST) with 3-pin plug-in connectors cable 1 m, 6 x 0,75 mm ² (BFN 2xx-T-ST) with 6-pin plug-in connectors	
Response temperature thermal fuse	duct outside temperature +72°C duct inside temperature +72°C	

Actuator BELIMO BF 230-TN(-ST)

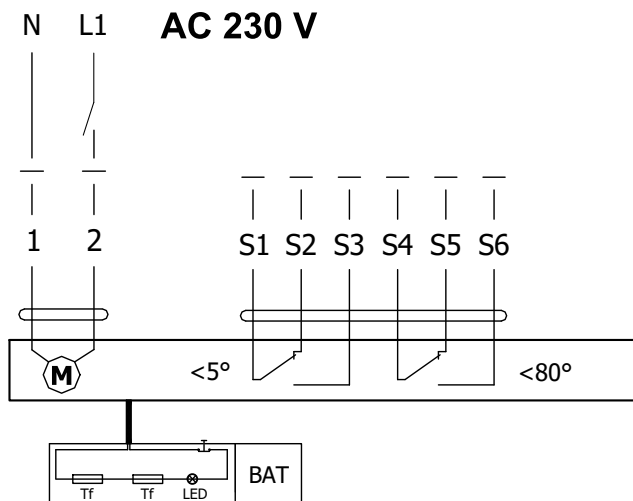

Actuator BELIMO BF 24-TN (-ST)

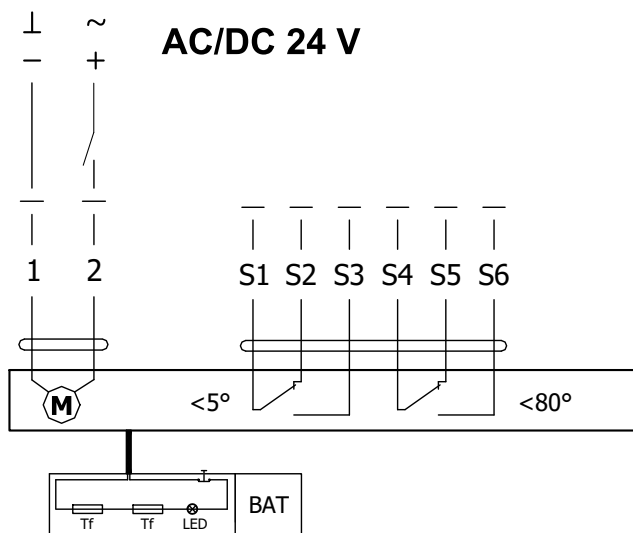

Actuator BELIMO BF 230-TN(-ST), BF 24-TN(-ST)

Actuator BELIMO - 18 Nm/ 12 Nm Spring	BF 230-TN(-ST)	BF 24-TN(-ST)
Power voltage	AC 230 V 50/60Hz	AC/DC 24 V 50/60Hz
Power consumption - in operation - in rest position	8,5 W 3 W	7 W 2 W
Dimensioning	11 VA (I _{max} 8,3 A @ 5 ms)	10 VA (I _{max} 8,3 A @ 5 ms)
Protection class	II	III
Degree of protection	IP 54	
Running time - motor - spring return	120 s ~ 16 s	
Ambient temperature - normal duty - safety duty - non-operating temperature	-30°C ... +50°C The safe position will be attained up to max. +75°C -40°C ... +50°C	
Connection - supply/control - auxiliary switch	cable 1 m, 2 x 0,75 mm ² (BF 2xx-TN-ST) with 3-pin plug-in connectors cable 1 m, 6 x 0,75 mm ² (BF 2xx-TN-ST) with 6-pin plug-in connectors	
Response temperature thermal fuse	duct outside temperature +72°C duct inside temperature +72°C	

Thermoelectric activation device BAT

- If the thermal fuse Tf1 is interrupted (due to temperature outside the duct), it is necessary to replace the spring return actuator. Thermoelectric activation device BAT is integral part of the actuator.
- If the thermal fuse Tf2 is interrupted (due to temperature inside the duct), only the spare part ZBAT 72 (95/120/140) needs to be replaced (acc.to the activation temperature).
- When one of the thermal fuses responds, the supply voltage is interrupted permanently and irreversibly.
- The function (interruption of the supply voltage) can be checked by pressing the test button.
- Installation is carried out with the pre-assembled, self-tapping screws.



BELIMO ZBAT 72
Black (BK) = 72°C (standard)

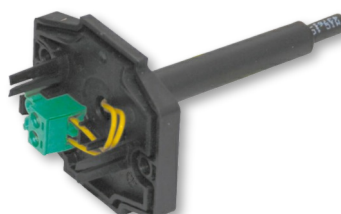

BELIMO ZBAT 95
Grey (GY) = 95°C

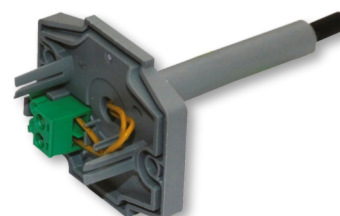

BELIMO ZBAT 120
Orange (OG) = 120°C

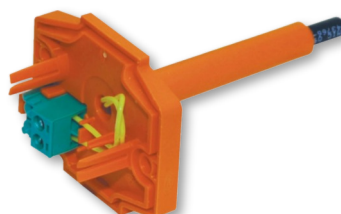

BELIMO ZBAT 140
Red (RD) = 140°C

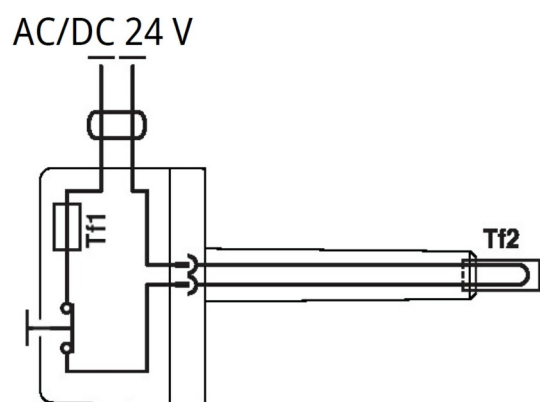
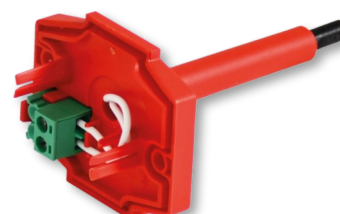

Thermoelectric activation device BAT 72 (95/120/140)

Power voltage	AC/DC 24 V 50/60Hz
Rated current	1 A
AC/DC throughput resistance	<1 Ω
Protection class	III
Degree of protection	IP 54
Probe length	65 mm
Ambient temperature	-30°C ... +50°C
Storage temperature	-40°C ... +50°C
Ambient humidity	Max. 95% RH, non-condensing
Connection supply	Cable 1 m, 2 x 0.5 mm ² , Betaflam cable heatresistant up to 145°C
Response temperature thermal fuse	Duct inside temperature +72 (95/120/140)°C Duct outside temperature +72 (95/120/140)°C

Design .41 and .51

- Design .41 or .51 with actuator and smoke detector ORS 142 K. The voltage can be AC 230 V or 24 V DC. Design .41 with voltage AC 230 V is equipped with power supply device ZNP-10-24 and with actuator BF 24-TN (BFL 24-T, BFN 24-T).
- The smoke detector is activated when smoke spreads in air duct system. Deactivation of the smoke detector alarm

status is provided by interruption of supply voltage for min. 2s.

- Signalisation of damper blades position "OPEN" and "CLOSE" is provided by two microswitches.
- Optical smoke detectors ORS 142K and power supply unit ZPN-10-24 are delivered in bulk

Design .41 with actuator BF 24-TN (BFL, BFN 24-T), with smoke detector ORS 142 K and with power supply device ZNP-10-24 (voltage AC 230 V)

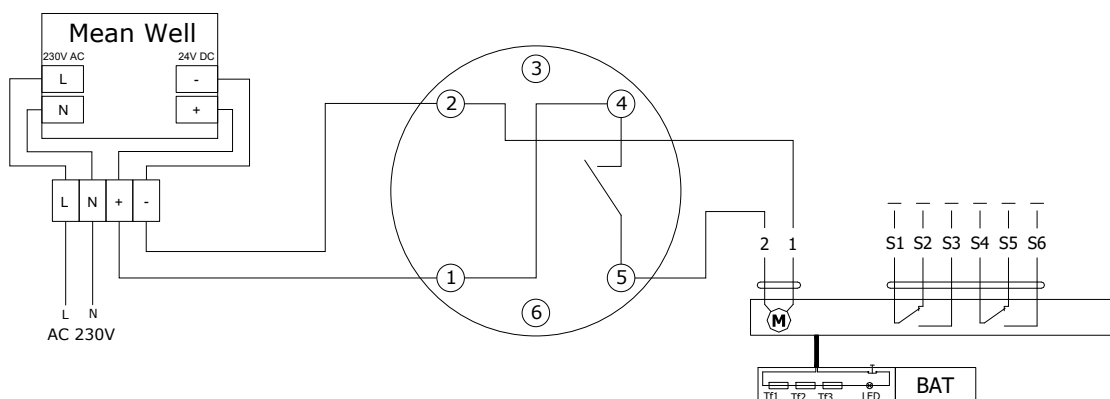

Design .51 with actuator BF 24-TN (BFL, BFN 24-T), with smoke detector ORS 142 K (voltage 24 V DC)

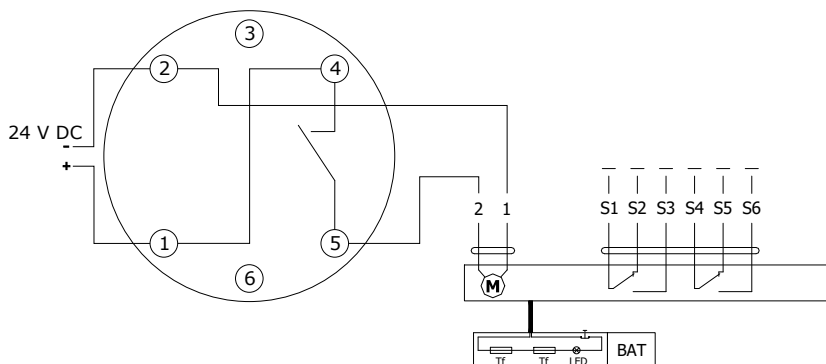

Power supply device ZNP-10-24

Supply voltage	AC 230 V (50-60Hz)
Power consumption - no-load (max.)	9 VA/2 W
Power consumption - under load (max.)	16 VA/13 W
Output voltage	DC 24 V volatile AC 24 V
Voltage - no-load AC (max.)	32 V
Voltage - no-load DC (max.)	43 V
Degree of protection	IP40 front panel / IP20 clamps
Ambient temperature	-20°C ... +40°C
Storage temperature	-20°C ... +60°C
Dimensions	90 x 52 x 65 mm
Weight	368 g

Optical smoke detector ORS 142 K with the socket 143A

- The smoke detector ORS 142 K is used for early smoke detection in rooms or inside the ventilation system.
- The sensor operates on the light scatter principle. Inside the scanning chamber is a light source and a light sensor, in the normal state the light from the source does not fall on the sensor. Only when smoke enters the scanning chamber the light is scattered and falls on the sensor.
- The smoke detector can be connected directly to the actuator (design .51) or to the ZNP-10-24 power supply unit (design .41)
- By early detection of smoke, it can be effectively prevented from spreading of smoke through the

ventilation system. In addition to smoke detection, the sensor can distinguish and signal slight and heavy contamination, e.g. the presence of large amounts of dust.

- The ORS 142 K smoke detector has an alarm memory, i.e. if the alarm is triggered, the safety relay opens and stays in this state even if the smoke disappears from the scanning chamber. The sensor remains in the alarm state until the power supply is briefly reset.
- On the pin 3, an external device can be connected via RS-Bus communication to report the status of the sensor.
- Pin 6 has no connection to the detector and is designed as a load-bearing structure in the base.

ORS 142 K



Socket 143A



RS-Bus communication

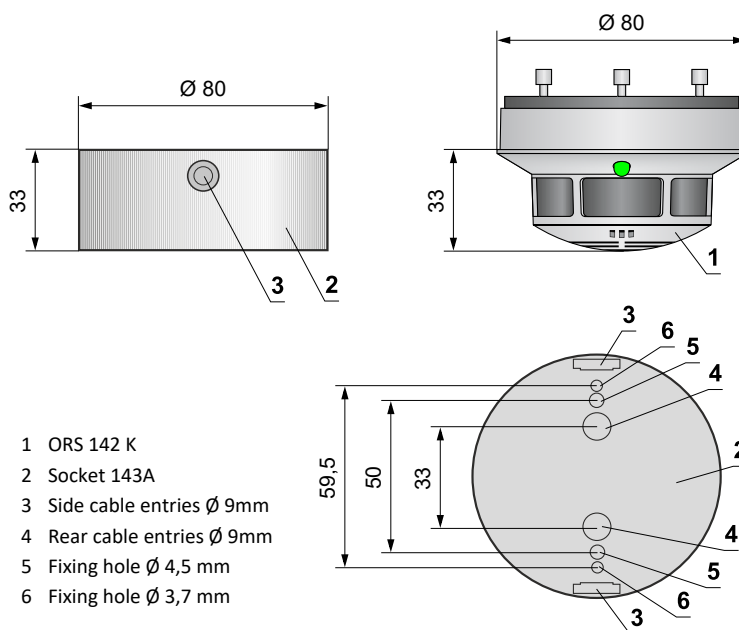
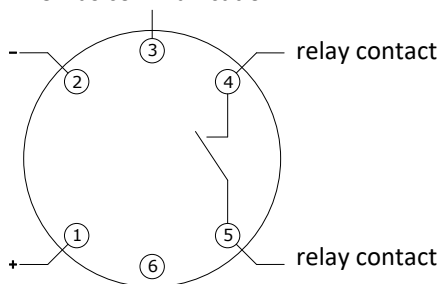

Relay contact		LED	
In operation		Green	Shines
Slight contamination		Green / Yellow	Flashes
Heavy contamination		Green / Yellow	Flashes
Fault		Yellow	Shines
Alarm		Red	Shines
Power Off		Off	-

Optical smoke detector ORS 142 K with the socket 143A

Operating voltage	18 ... 28 V DC
Residual ripple	≤ 200 mV
Power Consumption Socket (without actuator)	max. 22 mA
Degree of protection	IP 42
Ambient temperature	-20°C ... +75°C
Additional temperature sensor	+70°C
Connection - net	Cabel 1m, connected to terminals 1, 2 and 4
- motor	Actuator connected on the terminals 2 and 5
- power supply device ZNP-10-24	Cabel 1m, connected to terminals 1, 2, 4 and 5

III. DIMENSIONS

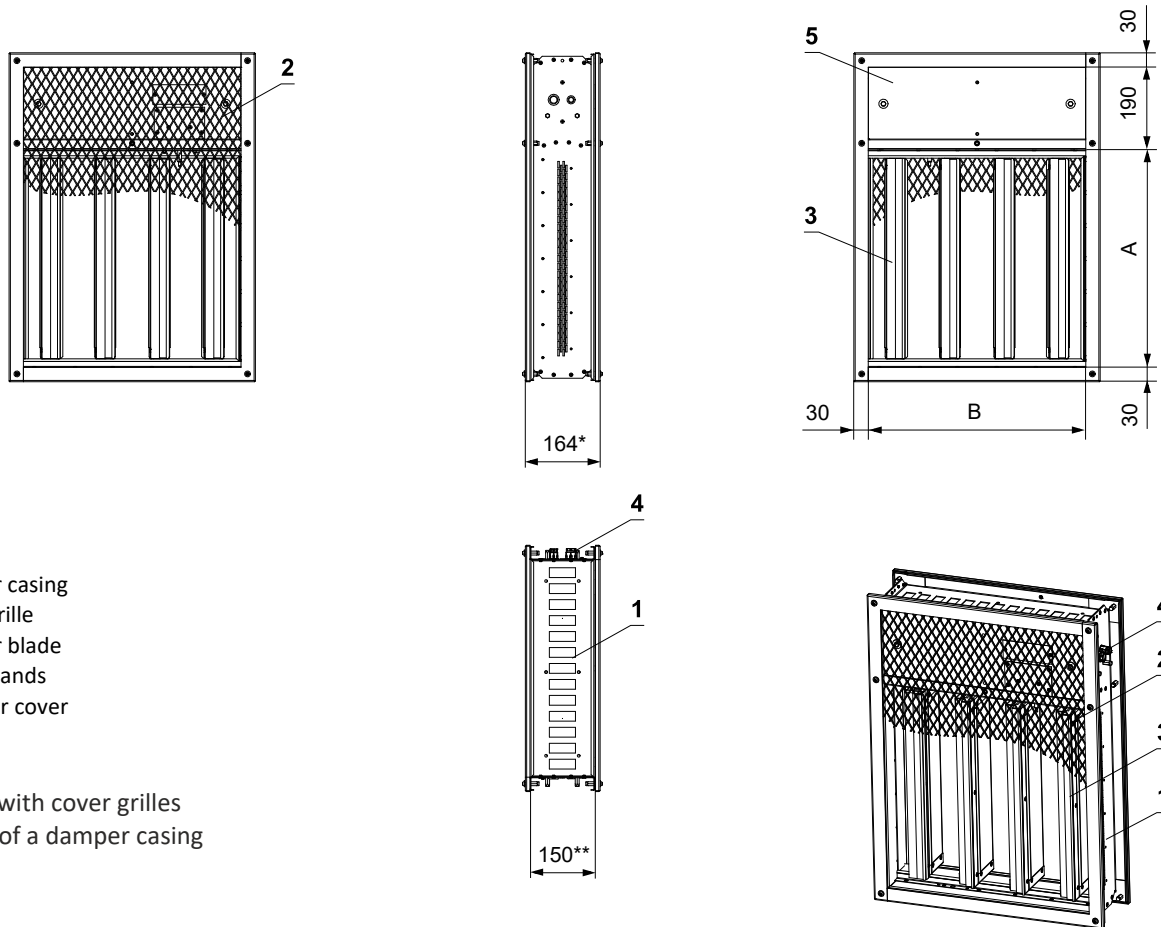

- 1 Damper casing
- 2 Cover grille
- 3 Damper blade
- 4 Cable glands
- 5 Actuator cover

* Depth with cover grilles
 ** Depth of a damper casing

Connecting dimensions of nuts M6

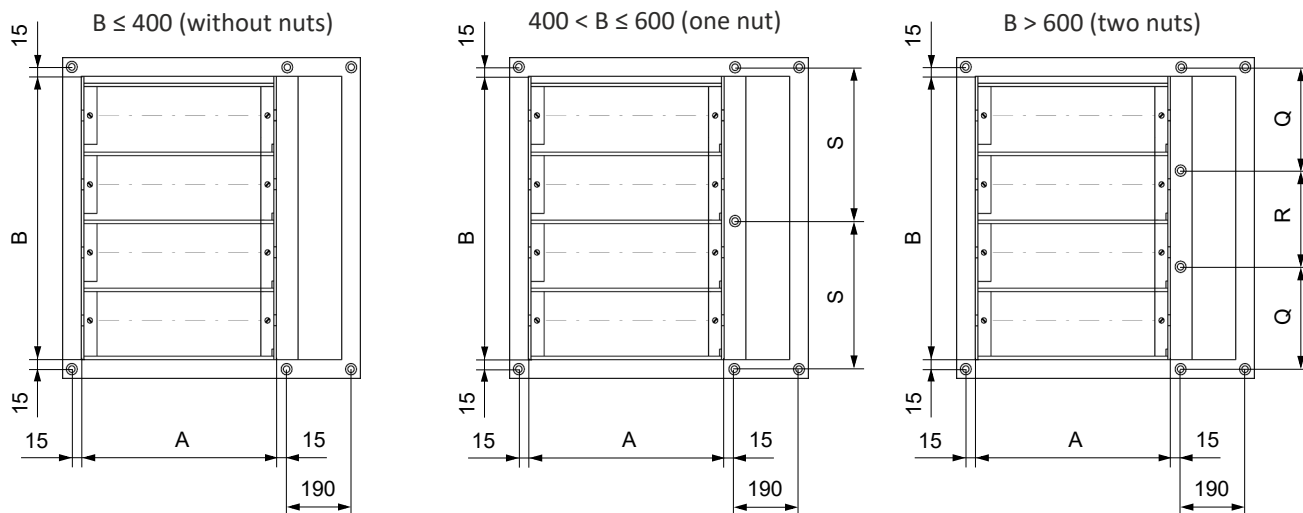

B [mm]	R [mm]	Q [mm]	S [mm]	B [mm]	R [mm]	Q [mm]	S [mm]
300	/	/	/	650	220	230	/
315	/	/	/	700	240	245	/
355	/	/	/	710	240	250	/
400	/	/	/	750	250	265	/
450	/	/	240	800	270	280	/
500	/	/	265	850	290	295	/
560	/	/	295	900	300	315	/
600	/	/	315	950	320	330	/
630	210	225	/	1000	340	345	/

Technical parameters

A x B [mm]	Number of blades	Weight [kg]		Effective area Sef [m ²]	Actua.	A x B [mm]	Number of blades	Weight [kg]		Effective area Sef [m ²]	Actua.
		FDML*	1 KMM					FDML*	1 KMM		
200 x	300	2	15,3	1,0	0,0276	300 x	300	2	17,2	1,2	0,0444
	315	2	15,9	1,1	0,0284		315	2	17,9	1,2	0,0457
	355	3	17,1	1,1	0,0349		355	3	19,2	1,3	0,0562
	400	3	18,8	1,2	0,0423		400	3	21,1	1,4	0,0681
	450	4	20,8	1,3	0,0440		450	4	23,3	1,5	0,0708
	500	4	22,8	1,4	0,0522		500	4	25,5	1,6	0,0840
	560	4	25,0	1,5	0,0554		560	4	28,1	1,8	0,0892
	600	5	26,1	1,6	0,0620		600	5	29,3	1,9	0,0998
	630	5	27,4	1,7	0,0669		630	5	30,6	2,3	0,1077
	650	5	28,0	1,7	0,0702		650	5	31,3	2,4	0,1130
	700	6	29,7	1,8	0,0718		700	6	33,6	2,5	0,1156
	710	6	30,3	1,8	0,0735		710	6	34,2	2,5	0,1183
	750	6	31,9	1,9	0,0800		750	6	35,9	2,6	0,1288
	800	6	33,6	2,4	0,0833		800	6	38,0	2,7	0,1341
	850	7	35,2	2,5	0,0899		850	7	39,7	2,8	0,1447
	900	7	37,4	2,6	0,0981		900	7	41,8	3,0	0,1579
950	8	38,8	2,7	0,0997	950	8	43,7	3,1	0,1605		
1000	8	41,0	2,9	0,1079	1000	8	45,9	3,2	0,1737		
250 x	300	2	16,3	1,1	0,0360	315 x	300	2	17,5	1,2	0,0469
	315	2	16,9	1,2	0,0370		315	2	18,2	1,3	0,0483
	355	3	18,1	1,2	0,0456		355	3	19,5	1,4	0,0594
	400	3	19,9	1,3	0,0552		400	3	21,4	1,5	0,0720
	450	4	22,0	1,4	0,0574		450	4	23,7	1,6	0,0748
	500	4	24,2	1,5	0,0681		500	4	25,9	1,7	0,0887
	560	4	26,5	1,7	0,0723		560	4	28,5	1,8	0,0943
	600	5	27,7	1,7	0,0809		600	5	29,7	2,3	0,1055
	630	5	29,0	1,8	0,0873		630	5	31,1	2,3	0,1138
	650	5	29,7	1,8	0,0916		650	5	31,8	2,4	0,1194
	700	6	31,8	2,3	0,0937		700	6	34,1	2,5	0,1222
	710	6	32,3	2,4	0,0959		710	6	34,7	2,5	0,1250
	750	6	34,0	2,4	0,1044		750	6	36,5	2,6	0,1362
	800	6	36,0	2,6	0,1087		800	6	38,6	2,8	0,1417
	850	7	37,6	2,7	0,1173		850	7	40,3	2,9	0,1529
	900	7	39,6	2,8	0,1280		900	7	42,4	3,0	0,1668
950	8	41,4	2,9	0,1301	950	8	44,4	3,2	0,1696		
1000	8	43,4	3,0	0,1408	1000	8	46,6	3,3	0,1836		
280 x	300	2	16,8	1,2	0,0410	355 x	300	2	18,3	1,3	0,0536
	315	2	17,5	1,2	0,0422		315	2	19,0	1,3	0,0552
	355	3	18,7	1,3	0,0520		355	3	20,3	1,4	0,0679
	400	3	20,6	1,4	0,0630		400	3	22,3	1,5	0,0823
	450	4	22,8	1,5	0,0654		450	4	24,7	1,6	0,0855
	500	4	25,0	1,6	0,0776		500	4	27,0	1,8	0,1014
	560	4	27,5	1,7	0,0825		560	4	29,8	2,3	0,1078
	600	5	28,6	1,8	0,0922		600	5	31,3	2,4	0,1206
	630	5	30,0	1,9	0,0996		630	5	32,7	2,5	0,1302
	650	5	30,7	2,3	0,1044		650	5	33,5	2,5	0,1365
	700	6	32,9	2,4	0,1069		700	6	35,6	2,6	0,1397
	710	6	33,4	2,4	0,1093		710	6	36,1	2,7	0,1429
	750	6	35,2	2,5	0,1191		750	6	38,0	2,8	0,1557
	800	6	37,2	2,7	0,1240		800	6	40,2	2,9	0,1621
	850	7	38,8	2,8	0,1337		850	7	42,0	3,0	0,1748
	900	7	40,9	2,9	0,1459		900	7	44,2	3,2	0,1908
950	8	42,8	3,0	0,1484	950	8	46,3	3,3	0,1940		
1000	8	44,9	3,1	0,1606	1000	8	48,5	3,4	0,2099		

* For design with ZNP-10-24 power supply, a weight of 0,4 kg must be added.

A x B [mm]	Number of blades	Weight [kg]		Effective area Sef [m²]	Actua.	A x B [mm]	Number of blades	Weight [kg]		Effective area Sef [m²]	Actua.	
		FDML*	1 KMM					FDML*	1 KMM			
400 x	300	2	19,1	1,4	0,0612	560 x	300	2	22,2	1,7	0,0880	
	315	2	19,9	1,4	0,0630		315	2	23,1	1,7	0,0907	BFL
	355	3	21,2	1,5	0,0775		355	3	24,8	1,8	0,1116	BFL
	400	3	23,3	1,6	0,0939		400	3	27,2	2,3	0,1352	
	450	4	25,8	1,7	0,0976		450	4	30,0	2,5	0,1404	BFL
	500	4	28,2	1,9	0,1158		500	4	32,8	2,6	0,1666	
	560	4	31,1	2,4	0,1230		560	4	36,3	2,8	0,1771	BFL
	600	5	32,7	2,5	0,1376		600	5	37,7	2,9	0,1981	
	630	5	34,2	2,6	0,1485		630	5	39,4	3,0	0,2138	BFN
	650	5	35,0	2,6	0,1558		650	5	40,3	3,1	0,2243	
	700	6	37,2	2,8	0,1594		700	6	42,9	3,3	0,2295	BFN
	710	6	37,8	2,8	0,1631		710	6	43,5	3,3	0,2348	
	750	6	39,7	2,9	0,1776		750	6	45,7	3,4	0,2557	BFN
	800	6	42,1	3,0	0,1849		800	6	48,6	3,6	0,2662	
	850	7	43,9	3,2	0,1995		850	7	52,3	3,7	0,2872	BFN
	900	7	46,2	3,3	0,2177		900	7	54,9	3,9	0,3134	
950	8	48,4	3,5	0,2213	950	8	57,5	4,0	0,3186	BF		
1000	8	50,7	3,6	0,2395	1000	8	60,1	4,2	0,3448			
450 x	300	2	20,1	1,5	0,0696	600 x	300	2	22,9	1,7	0,0948	BFL
	315	2	20,9	1,5	0,0716		315	2	23,9	1,8	0,0976	BFL
	355	3	22,2	1,6	0,0882		355	3	25,6	1,9	0,1201	BFL
	400	3	24,7	1,7	0,1068		400	3	28,1	2,4	0,1455	
	450	4	27,3	1,8	0,1110		450	4	31,0	2,6	0,1512	BFL
	500	4	29,8	2,4	0,1317		500	4	33,8	2,7	0,1794	
	560	4	33,0	2,5	0,1399		560	4	37,6	2,9	0,1906	BFL
	600	5	34,2	2,6	0,1565		600	5	38,9	3,1	0,2132	
	630	5	35,8	2,7	0,1689		630	5	40,7	3,1	0,2301	BFN
	650	5	36,6	2,8	0,1772		650	5	41,6	3,2	0,2414	
	700	6	39,0	2,9	0,1813		700	6	44,3	3,4	0,2470	BFN
	710	6	39,6	3,0	0,1855		710	6	45,0	3,4	0,2527	
	750	6	41,6	3,1	0,2020		750	6	47,2	3,5	0,2752	BFN
	800	6	44,1	3,2	0,2103		800	6	50,2	3,7	0,2865	
	850	7	46,0	3,3	0,2269		850	7	53,9	3,8	0,3091	BFN
	900	7	48,4	3,5	0,2476		900	7	56,6	4,0	0,3373	
950	8	50,7	3,6	0,2517	950	8	59,3	4,2	0,3429	BF		
1000	8	53,2	3,8	0,2724	1000	8	62,1	4,3	0,3711			
500 x	300	2	21,0	1,6	0,0780	630 x	300	2	23,5	1,8	0,0998	BFL
	315	2	21,9	1,6	0,0803		315	2	24,5	1,8	0,1028	BFL
	355	3	23,3	1,7	0,0988		355	3	26,2	1,9	0,1265	BFL
	400	3	25,9	1,8	0,1197		400	3	28,7	2,5	0,1533	
	450	4	28,5	2,3	0,1244		450	4	31,8	2,6	0,1592	BFL
	500	4	31,2	2,5	0,1476		500	4	34,6	2,8	0,1889	
	560	4	34,5	2,7	0,1568		560	4	38,5	3,0	0,2008	BFL
	600	5	35,8	2,8	0,1754		600	5	39,9	3,1	0,2245	
	630	5	37,4	2,9	0,1893		630	5	41,6	3,2	0,2424	BFN
	650	5	38,3	2,9	0,1986		650	5	42,6	3,3	0,2542	
	700	6	40,7	3,1	0,2032		700	6	45,4	3,5	0,2602	BFN
	710	6	41,4	3,1	0,2079		710	6	46,1	3,5	0,2661	
	750	6	43,5	3,2	0,2264		750	6	48,4	3,6	0,2899	BFN
	800	6	46,2	3,4	0,2357		800	6	51,5	3,8	0,3018	
	850	7	48,1	3,5	0,2543		850	7	55,2	3,9	0,3255	BFN
	900	7	50,6	3,7	0,2775		900	7	58,0	4,1	0,3552	
950	8	54,7	3,8	0,2821	950	8	60,7	4,3	0,3612	BF		
1000	8	57,2	4,0	0,3053	1000	8	63,5	4,4	0,3909			

* For design with ZNP-10-24 power supply, a weight of 0,4 kg must be added.

A x B [mm]	Number of blades	Weight [kg]		Effective area Sef [m ²]	Actua.	A x B [mm]	Number of blades	Weight [kg]		Effective area Sef [m ²]	Actua.
		FDML*	1 KMM					FDML*	1 KMM		
650 x	300	2	23,9	1,8	0,1032	750 x	300	2	25,8	2,0	0,1200
	315	2	24,9	1,9	0,1062		315	2	26,9	2,0	0,1235
	355	3	26,6	2,0	0,1308		355	3	28,7	2,6	0,1521
	400	3	29,2	2,5	0,1584		400	3	31,4	2,8	0,1842
	450	4	32,3	2,7	0,1646		450	4	34,8	2,9	0,1914
	500	4	35,2	2,9	0,1953		500	4	37,9	3,1	0,2271
	560	4	39,1	3,1	0,2075		560	4	42,2	3,3	0,2413
	600	5	40,5	3,2	0,2321		600	5	43,6	3,5	0,2699
	630	5	42,3	3,3	0,2505		630	5	45,5	3,6	0,2913
	650	5	43,3	3,4	0,2628		650	5	46,6	3,6	0,3056
	700	6	47,7	3,5	0,2689		700	6	51,3	3,8	0,3127
	710	6	48,4	3,6	0,2751		710	6	52,0	3,9	0,3199
	750	6	50,7	3,7	0,2996		750	6	54,5	4,0	0,3484
	800	6	53,9	3,8	0,3119		800	6	58,0	4,2	0,3627
	850	7	56,1	4,0	0,3365		850	7	60,3	4,3	0,3913
	900	7	58,9	4,2	0,3672		900	7	63,3	4,5	0,4270
950	8	61,7	4,3	0,3733	950	8	66,3	4,7	0,4341		
1000	8	64,5	4,5	0,4040	1000	8	69,3	4,9	0,4698		
700 x	300	2	24,8	1,9	0,1116	800 x	300	2	26,8	2,1	0,1284
	315	2	25,9	1,9	0,1149		315	2	27,9	2,6	0,1322
	355	3	27,7	2,5	0,1414		355	3	29,7	2,7	0,1627
	400	3	30,3	2,6	0,1713		400	3	32,6	2,8	0,1971
	450	4	33,5	2,8	0,1780		450	4	36,0	3,0	0,2048
	500	4	36,5	3,0	0,2112		500	4	39,2	3,2	0,2430
	560	4	40,6	3,2	0,2244		560	4	43,7	3,5	0,2582
	600	5	42,0	3,3	0,2510		600	5	46,8	3,6	0,2888
	630	5	43,9	3,4	0,2709		630	5	48,8	3,7	0,3117
	650	5	44,9	3,5	0,2842		650	5	49,9	3,8	0,3270
	700	6	49,5	3,7	0,2908		700	6	53,1	4,0	0,3346
	710	6	50,2	3,7	0,2975		710	6	53,8	4,0	0,3423
	750	6	52,6	3,8	0,3240		750	6	56,4	4,1	0,3728
	800	6	56,0	4,0	0,3373		800	6	60,0	4,3	0,3881
	850	7	58,2	4,2	0,3639		850	7	62,4	4,5	0,4187
	900	7	61,1	4,4	0,3971		900	7	65,5	4,7	0,4569
950	8	64,0	4,5	0,4037	950	8	68,6	4,9	0,4645		
1000	8	66,9	4,7	0,4369	1000	8	71,8	5,1	0,5027		
710 x	300	2	25,0	1,9	0,1132	850 x	300	2	28,0	2,6	0,1368
	315	2	26,1	2,0	0,1166		315	2	29,2	2,7	0,1408
	355	3	27,9	2,5	0,1436		355	3	30,8	2,8	0,1734
	400	3	30,5	2,7	0,1739		400	3	33,7	3,0	0,2100
	450	4	33,8	2,8	0,1806		450	4	37,2	3,2	0,2182
	500	4	36,8	3,0	0,2143		500	4	40,6	3,4	0,2589
	560	4	40,9	3,2	0,2278		560	4	45,2	3,6	0,2751
	600	5	42,4	3,4	0,2548		600	5	48,4	3,7	0,3077
	630	5	44,2	3,5	0,2750		630	5	50,4	3,8	0,3321
	650	5	45,3	3,5	0,2885		650	5	51,6	3,9	0,3484
	700	6	49,9	3,7	0,2952		700	6	54,9	4,1	0,3565
	710	6	50,6	3,7	0,3020		710	6	55,6	4,1	0,3647
	750	6	53,0	3,9	0,3289		750	6	58,3	4,3	0,3972
	800	6	56,4	4,0	0,3424		800	6	62,1	4,5	0,4135
	850	7	58,6	4,2	0,3694		850	7	64,5	4,7	0,4461
	900	7	61,5	4,4	0,4031		900	7	67,7	4,9	0,4868
950	8	64,5	4,6	0,4098	950	8	71,0	5,1	0,4949		
1000	8	67,4	4,7	0,4435	1000	8	74,2	5,2	0,5356		

* For design with ZNP-10-24 power supply, a weight of 0,4 kg must be added.

A x B [mm]	Number of blades	Weight [kg]		Effective area Sef [m ²]	Actua.	A x B [mm]	Number of blades	Weight [kg]		Effective area Sef [m ²]	Actua.
		FDML*	1 KMM					FDML*	1 KMM		
900 x	300	2	28,9	2,7	0,1452	950 x	650	5	54,9	4,2	0,3912
	315	2	30,2	2,8	0,1495		700	6	58,4	4,4	0,4003
	355	3	31,8	2,9	0,1840		710	6	59,3	4,4	0,4095
	400	3	34,8	3,1	0,2229		750	6	62,0	4,6	0,4460
	450	4	38,5	3,3	0,2316		800	6	66,2	4,8	0,4643
	500	4	41,9	3,5	0,2748		850	7	68,7	5,0	0,5009
	560	4	46,8	3,7	0,2920		900	7	72,1	5,2	0,5466
	600	5	49,9	3,9	0,3266		950	8	75,6	5,4	0,5557
	630	5	52,0	4,0	0,3525		1000	8	79,1	5,6	0,6014
	650	5	53,2	4,1	0,3698		1000 x	300	2	30,8	2,9
700	6	56,7	4,3	0,3784	315	2		32,2	3,0	0,1668	
710	6	57,4	4,3	0,3871	355	3		33,8	3,1	0,2053	
750	6	60,2	4,5	0,4216	400	3		37,1	3,3	0,2487	
800	6	64,1	4,6	0,4389	450	4		42,6	3,5	0,2584	
850	7	66,6	4,8	0,4735	500	4		46,2	3,7	0,3066	
900	7	69,9	5,0	0,5167	560	4		51,5	4,0	0,3258	
950	8	73,3	5,2	0,5253	600	5		53,1	4,1	0,3644	
1000	8	76,6	5,4	0,5685	630	5		55,3	4,3	0,3933	
950 x	300	2	29,9	2,8	0,1536	650		5	56,6	4,4	0,4126
	315	2	31,2	2,9	0,1581	700	6	60,2	4,6	0,4222	
	355	3	32,8	3,0	0,1947	710	6	61,1	4,6	0,4319	
	400	3	35,9	3,2	0,2358	750	6	63,9	4,8	0,4704	
	450	4	39,7	3,4	0,2450	800	6	68,2	5,0	0,4897	
	500	4	43,2	3,6	0,2907	850	7	70,8	5,2	0,5283	
	560	4	48,3	3,8	0,3089	900	7	74,3	5,4	0,5765	
	600	5	51,5	4,0	0,3455	950	8	78,0	5,6	0,5861	
	630	5	53,6	4,1	0,3729	1000	8	81,5	5,8	0,6343	

* For design with ZNP-10-24 power supply, a weight of 0,4 kg must be added.

IV. INSTALLATION

Placement and installation

- The damper can be installed with blade axis vertically or horizontally, temperature sensor (BAT) must always be in damper upper part. The damper installation procedures must be done so that all load transfer from the fire separating constructions to the damper is absolutely excluded. Following air-conditioning duct must be suspended or supported so that all load transfer from the following duct to the fire damper is absolutely excluded. The gap between the installed damper and the fire separating construction must be perfectly filled with approved material.
- During the installation and plastering process, the actuating mechanism must be protected (covered) against damage and pollution. The damper casing should not be deformed during bricking in. Once the damper is built in, the damper blades should not grind against the damper casing during opening or closing.
- The distance between the fire damper and the construction (wall, ceiling) must be 75 mm at the minimum, according to EN 1366-2. If two or more dampers are to be installed in one fire separating construction, the distance between adjacent dampers must be 200 mm at the minimum, according to EN 1366-2.
- Fire dampers can be installed without following duct on one or both sides. In the case of this installation, the fire dampers must be equipped with cover grilles.
- For designs with an optical smoke detector, the best conditions for detecting smoke and combustion products must be ensured, i.e. the smoke detector must be located at the upper part of the room.
- It is recommended to install the dampers according to the local disposition in such a way that the side of the damper with the thermoelectric activation device is in line with the wall and the opening on the other side of the wall is permanently covered by a second cover grille fixed e.g. in the frame. The minimum thickness of the standard wall construction is 100 mm. In the case of an installation where one side of the damper is in line with the surface of the construction and the other side extends more than 25 mm from the construction, the extending part must be covered with fire-resistant boards. In the case of installation in a gypsum wall, the opening must be lined with reinforcement profiles.
- Dampers are not equipped with inspection openings. If these dampers are used as dampers for simple maintenance and revision they must be completed with connecting inspection part installed just behind the damper.
- The dampers must be installed so that the actuator cover can be easily removed from at least one side. It is recommended that the cover be accessible from the side where the thermoelectric activation device cover is located for easy access.

Minimum distance between the fire dampers and the construction

- minimum distance 200 mm between dampers, according to EN 1366-2
- minimum distance 75 mm between damper and construction (wall/ceiling), according to EN 1366-2

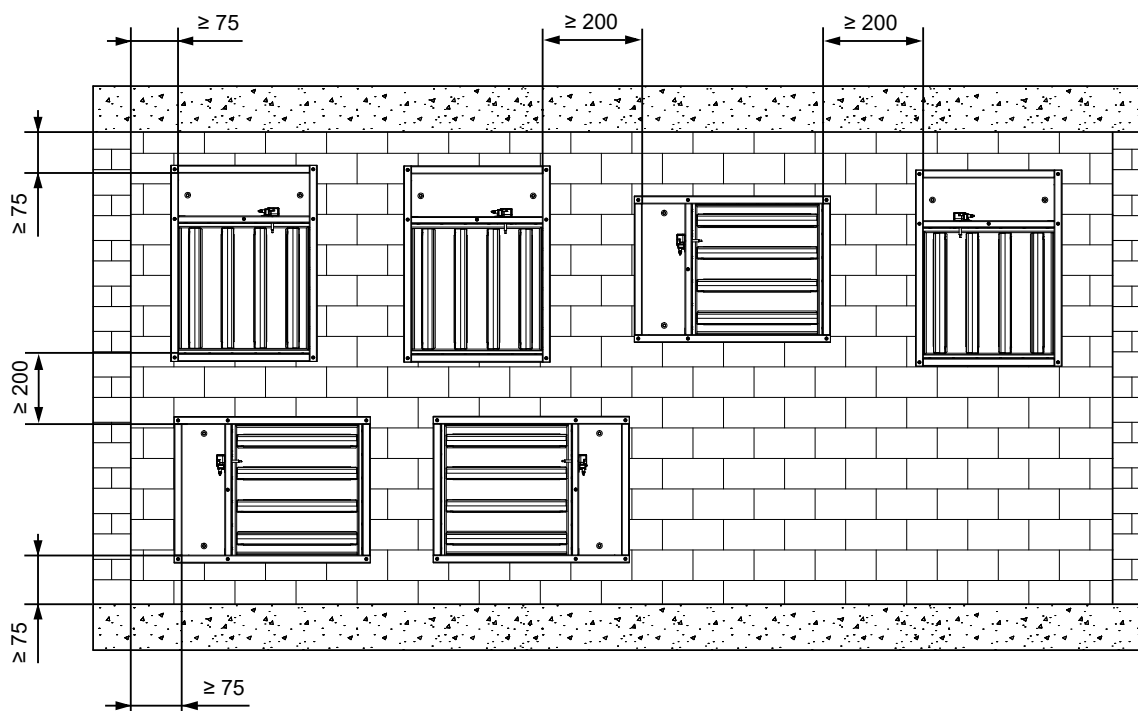

Dimensions of an installation opening

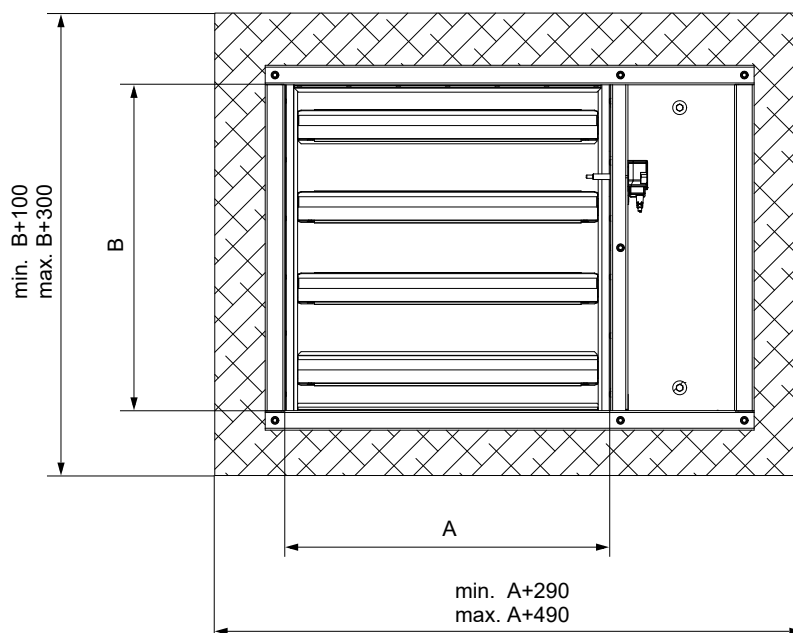

Grounding of the damper

- It is necessary to ground the damper casing before installation.

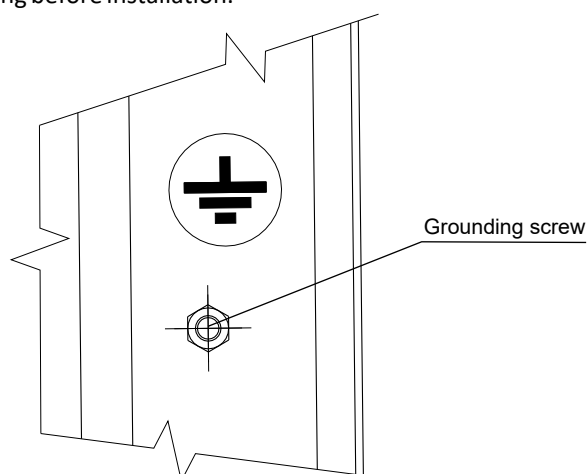

Statement of installations

Placement	wall/ceiling min. thickness [mm]	Method of installation	Fire resistance	Page
In solid wall construction	100	Mortar or gypsum	EI 90 (v _e i↔o) S	18
		Ablative Coated Batt		19
In gypsum wall construction	100	Mortar or gypsum	EI 90 (v _e i↔o) S	20
		Ablative Coated Batt		21
In solid ceiling construction	150	Mortar or gypsum	EI 90 (h _o i↔o) S	22

In solid wall construction

In solid wall construction - mortar or gypsum

EI 90 (v_e i↔o) S*
EI 120 (v_e i↔o)**

■ For connection of following duct → see page 27

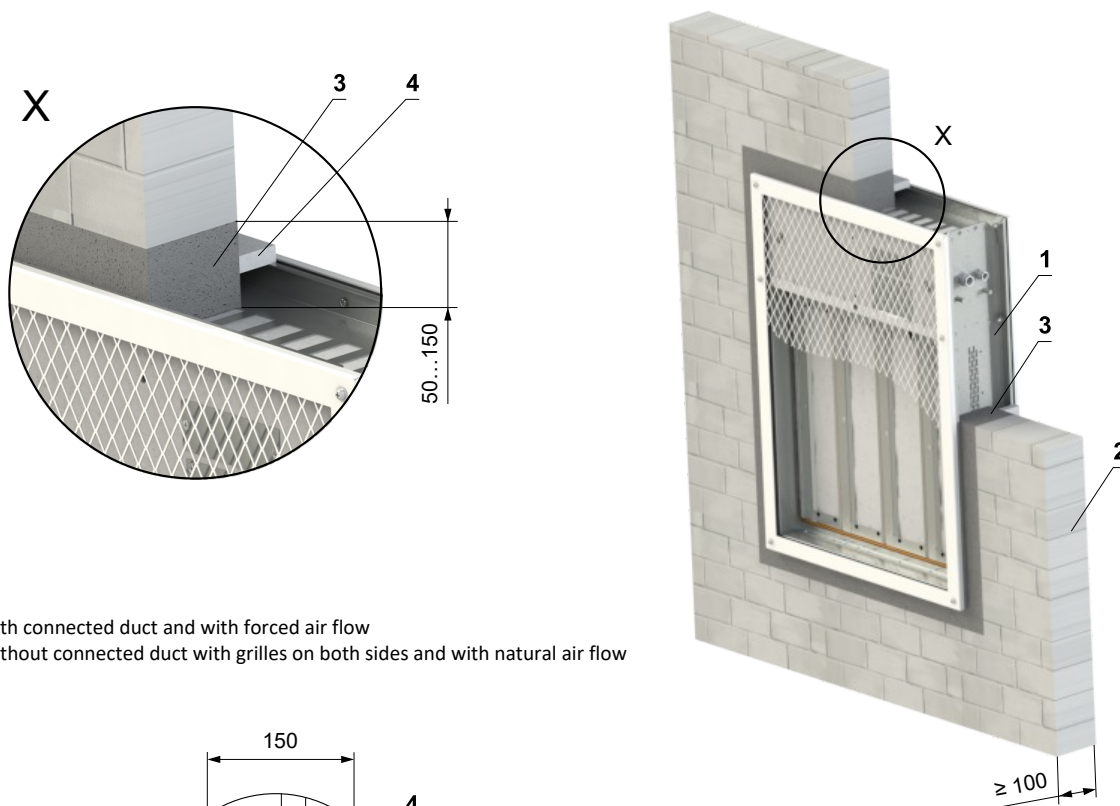

* In case with connected duct and with forced air flow
** In case without connected duct with grilles on both sides and with natural air flow

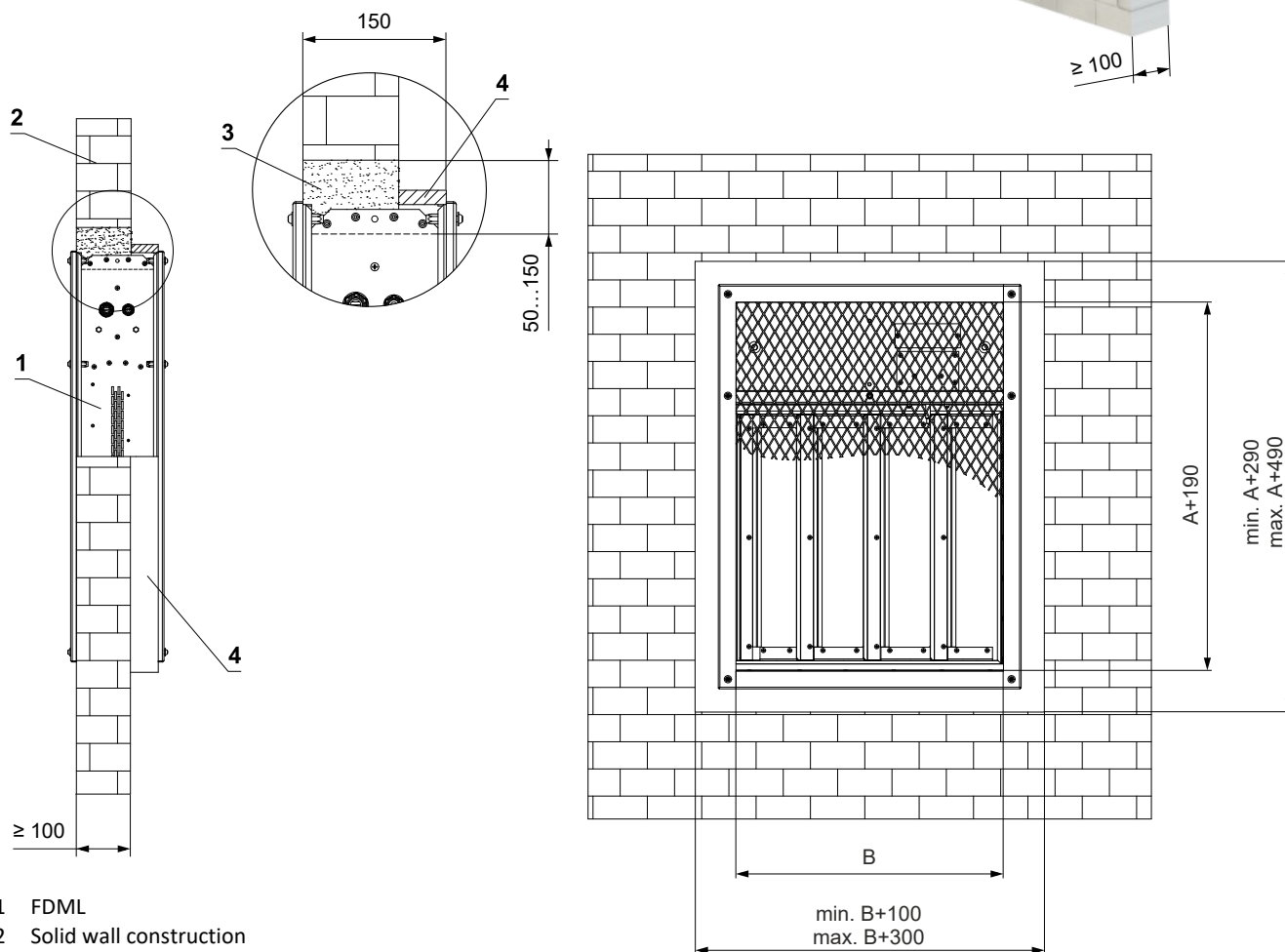

- 1 FDML
- 2 Solid wall construction
- 3 Mortar or gypsum
- 4 Fire-resistant cover boards - only if one side of the damper is in line with the surface of the construction and the other side extends more than 25 mm from the construction - (Promatect-H...) min. thickness 15 mm - connect the boards together with screws

In solid wall construction - Ablative Coated Batt

EI 90 (v_e i↔o) S*
EI 120 (v_e i↔o)**

■ For connection of following duct → see page 27

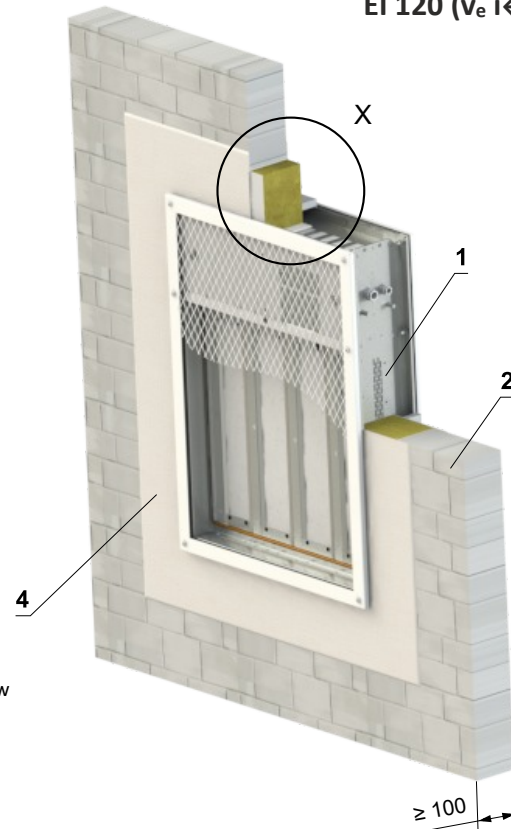
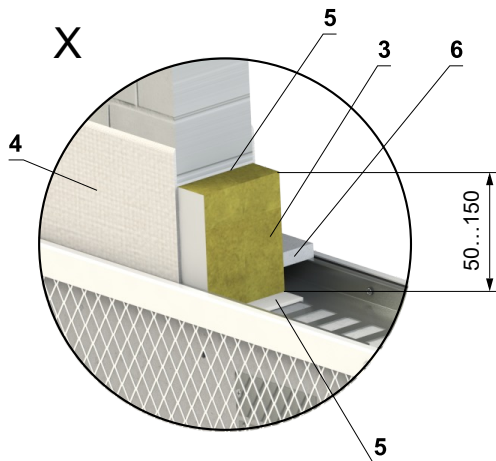

- * In case with connected duct and with forced air flow
- ** In case without connected duct with grilles on both sides and with natural air flow
- *** HILTI system can be replaced by a similar system with the same or higher thickness, density, fire reaction class, tested according to EN 1366-3.

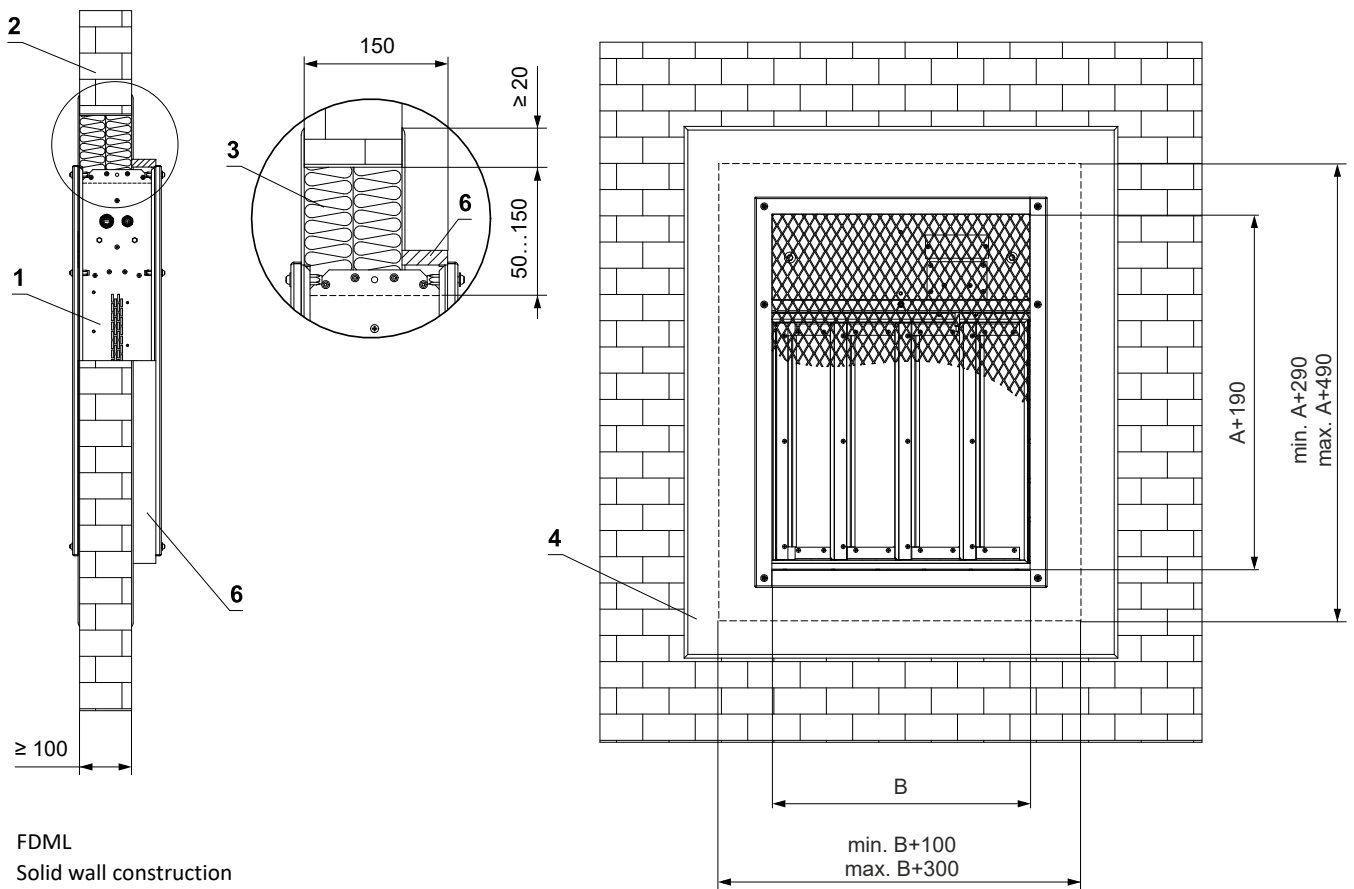

- 1 FDML
- 2 Solid wall construction
Ablative Coated Batt System HILTI***
- 3 Mineral wool board - min. density 140 kg/m³ (HILTI CFS-CT B 1S 140/50...)
- 4 Fire stop coating - th. 1 mm (HILTI CFS-CT...) - coating is overcoated on the support construction and on the damper casing/duct
- 5 Fire-resistant mastic - (HILTI CFS-S ACR...) fill the gap from both sides of the fire separation construction and around the perimeter of penetration and damper casing
- 6 Fire-resistant cover boards - only if one side of the damper is in line with the surface of the construction and the other side extends more than 25 mm from the construction - (Promatect-H...) min. thickness 15 mm - connect the boards together with screws

In gypsum wall construction

In gypsum wall construction - mortar or gypsum

EI 90 ($v_e i \leftrightarrow o$) S*
EI 120 ($v_e i \leftrightarrow o$)**

■ For connection of following duct → see page 27

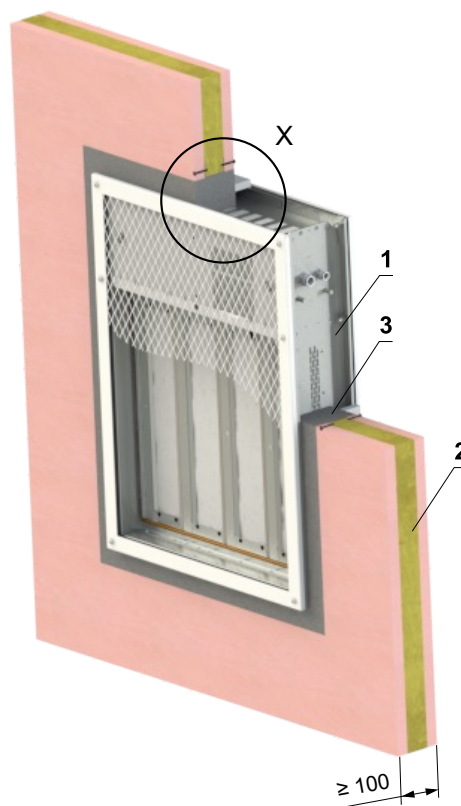
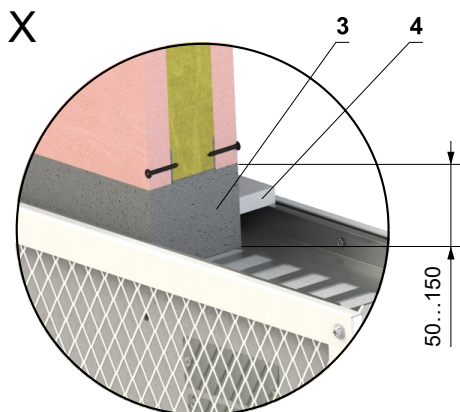

* In case with connected duct and with forced air flow

** In case without connected duct with grilles on both sides and with natural air flow

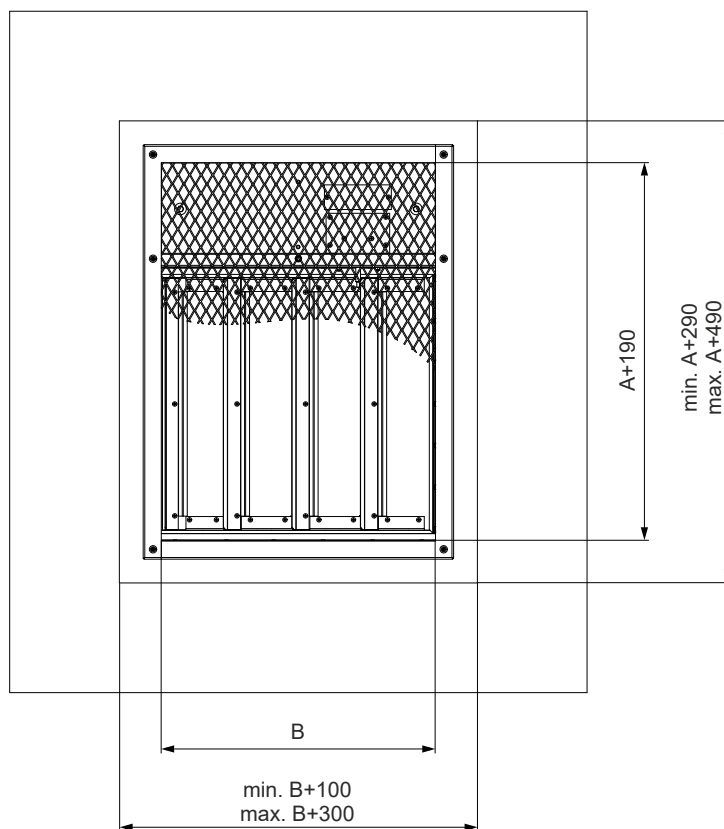
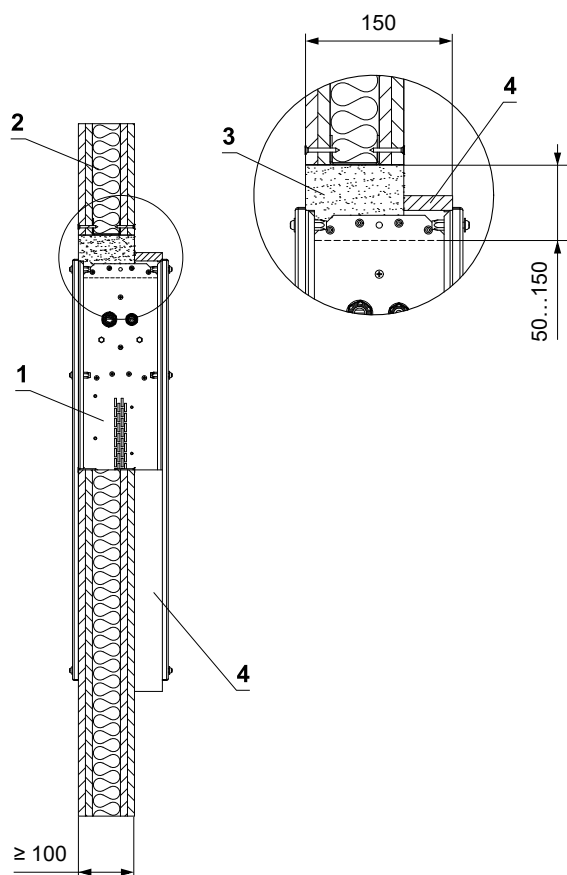

- 1 FDML
- 2 Gypsum wall construction
- 3 Mortar or gypsum
- 4 Fire-resistant cover boards - only if one side of the damper is in line with the surface of the construction and the other side extends more than 25 mm from the construction - (Promatect-H...) min. thickness 15 mm - connect the boards together with screws

In gypsum wall construction - Ablative Coated Batt

EI 90 (v_e i↔o) S*
EI 120 (v_e i↔o)**

- For connection of following duct → see page 27

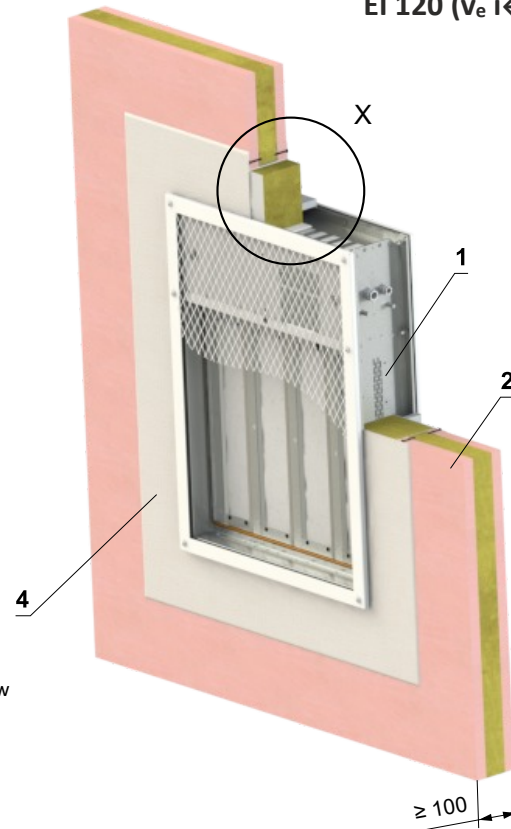
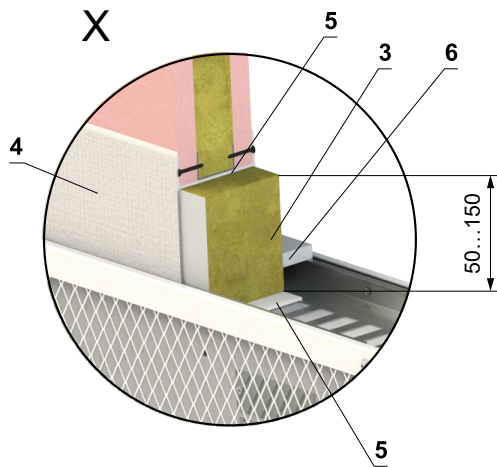

- * In case with connected duct and with forced air flow
- ** In case without connected duct with grilles on both sides and with natural air flow
- *** HILTI system can be replaced by a similar system with the same or higher thickness, density, fire reaction class, tested according to EN 1366-3.

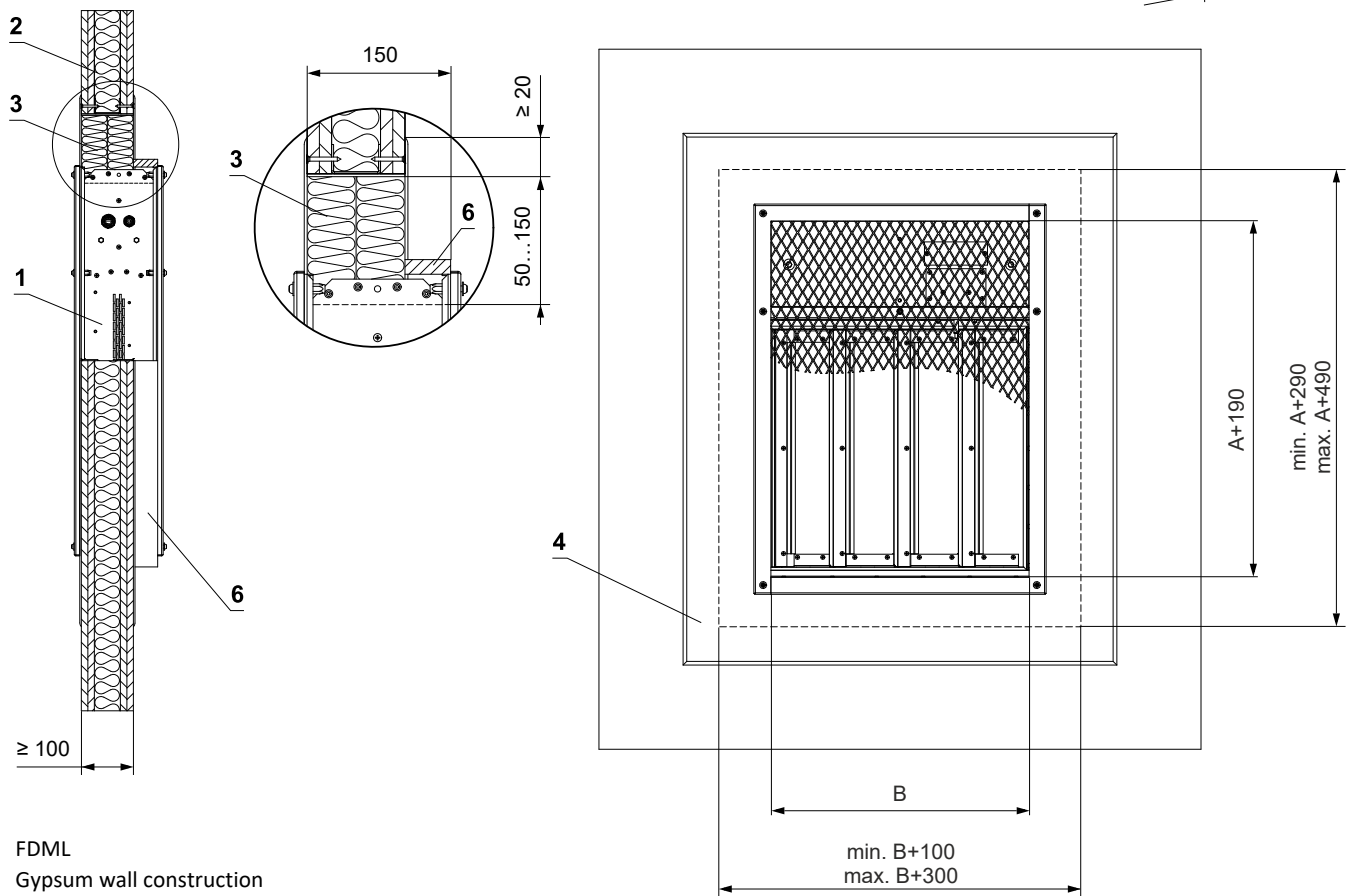

- 1 FDML
- 2 Gypsum wall construction
Ablative Coated Batt System HILTI***
- 3 Mineral wool board - min. density 140 kg/m³ (HILTI CFS-CT B 1S 140/50...)
- 4 Fire stop coating - th. 1 mm (HILTI CFS-CT...) - coating is overcoated on the support construction and on the damper casing/duct
- 5 Fire-resistant mastic - (HILTI CFS-S ACR...) fill the gap from both sides of the fire separation construction and around the perimeter of penetration and damper casing
- 6 Fire-resistant cover boards - only if one side of the damper is in line with the surface of the construction and the other side extends more than 25 mm from the construction - (Promatect-H...) min. thickness 15 mm - connect the boards together with screws

In solid ceiling construction

In solid ceiling construction - mortar or gypsum

- For connection of following duct → see page 27

EI 90 (h_o i↔o) S*
EI 120 (h_o i↔o)**

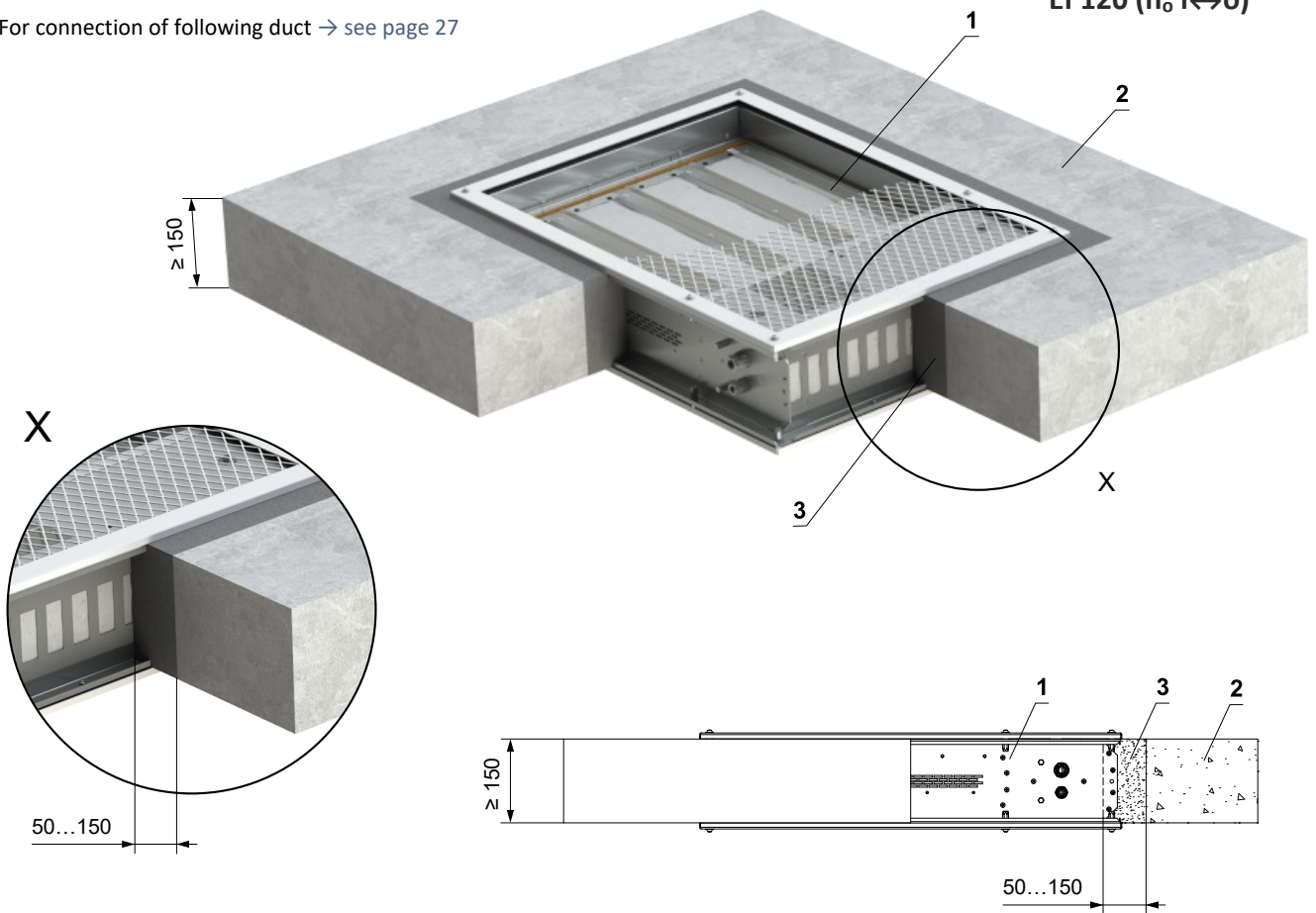

- * In case with connected duct and with forced air flow
- ** In case without connected duct with grilles on both sides and with natural air flow

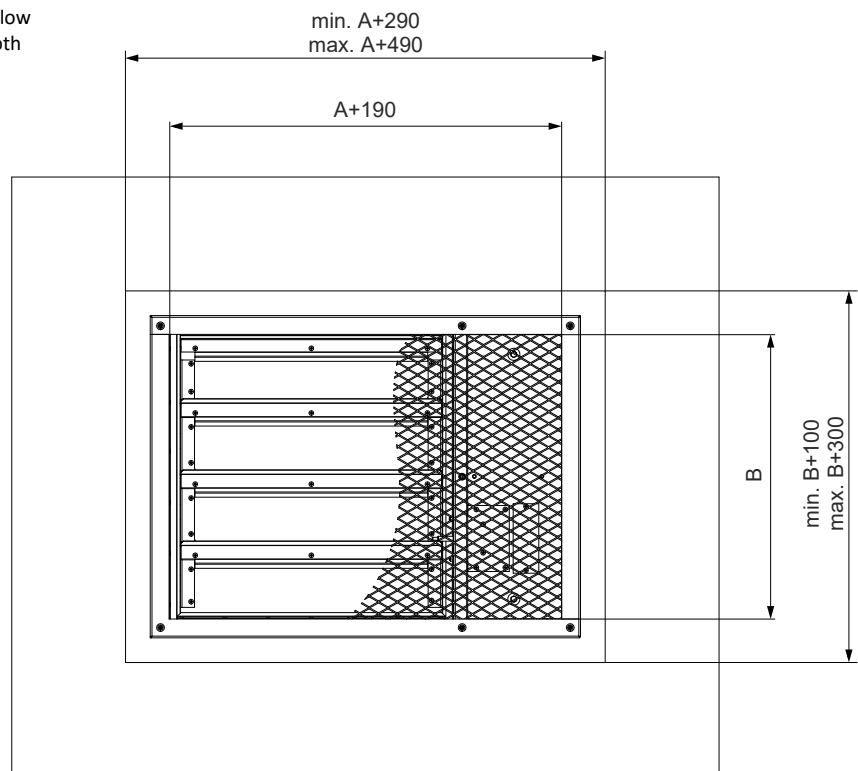

- 1 FDML
- 2 Solid ceiling construction
- 3 Mortar or gypsum

Examples of installation situations

Damper in line with the wall
(fire-resistant cover boards
required)

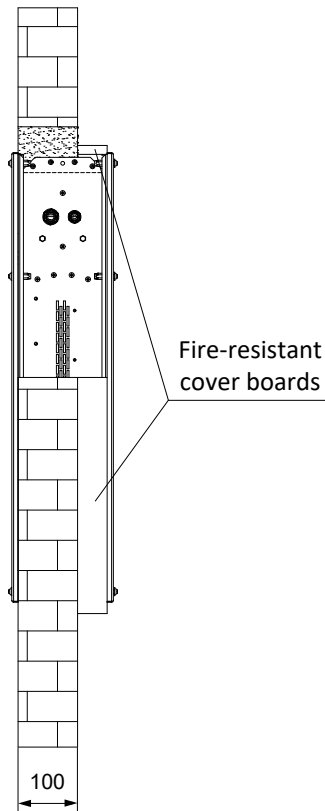

Damper in the centre of the wall
(fire-resistant cover
boards not required)

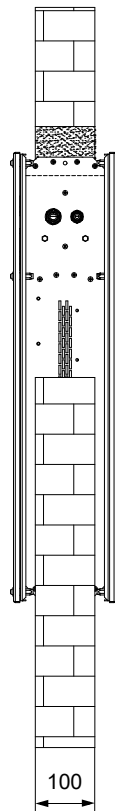

Damper in the wall 150 mm

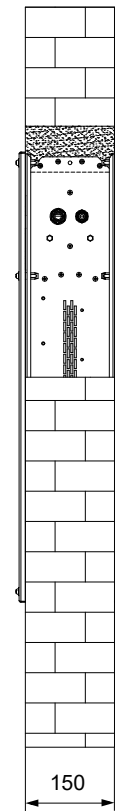

Damper with
grille on the wall

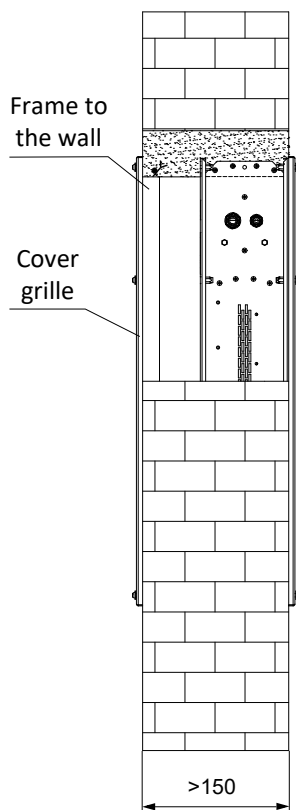

Damper with duct
and grille on the wall

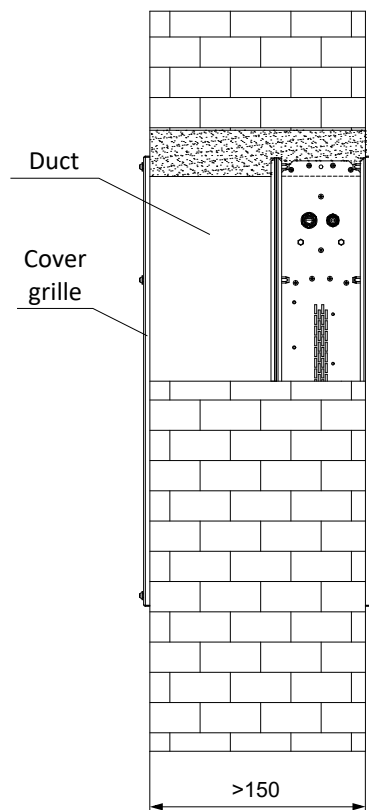

Damper with grille
inside the wall

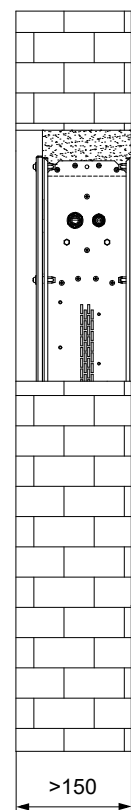

Examples of fixing FDML

In solid wall construction - mortar or gypsum/Ablative Coated Batt

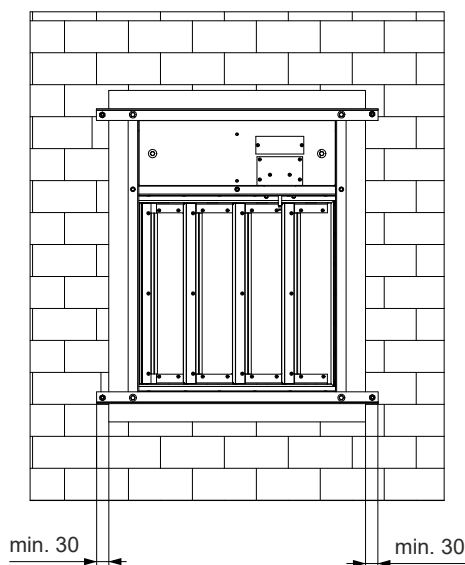
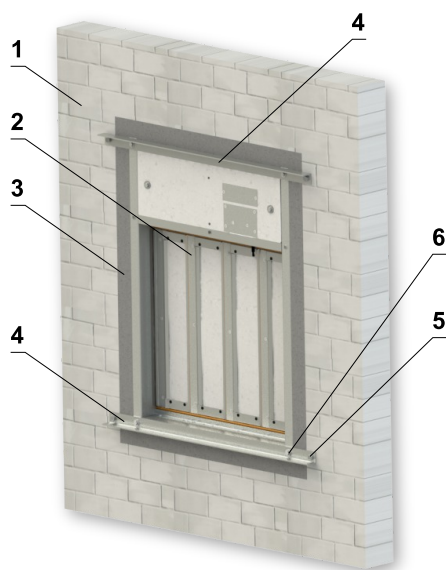

In gypsum wall construction - mortar or gypsum/Ablative Coated Batt

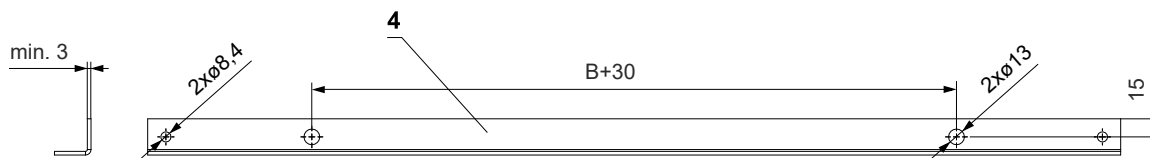
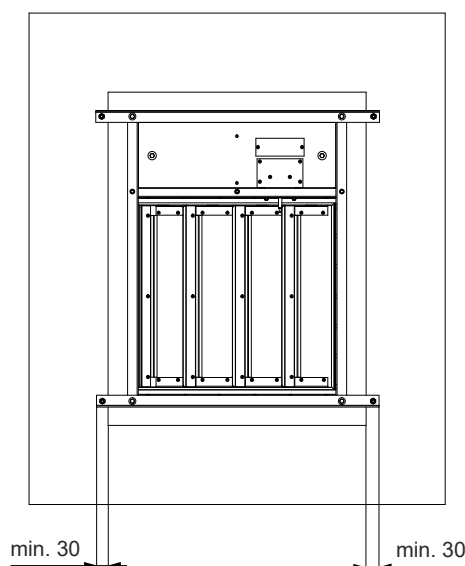
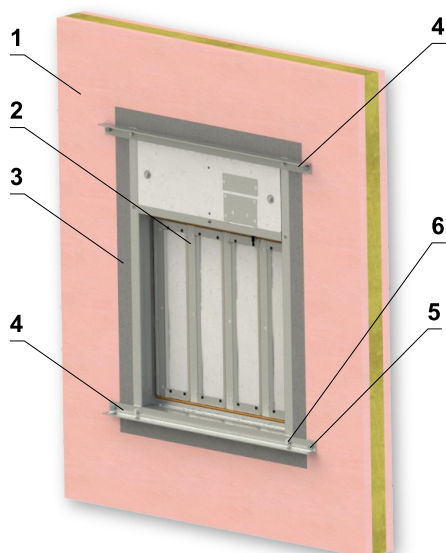

- Screw two L-profiles to the damper using M6x20 screws + washers and fix the L-profiles to the wall using M8 anchors and nuts (solid wall construction) or screws (gypsum wall construction - screws must go through a gypsum profile). Fill the gap between the damper and the wall with approved material. L-profiles must be removed before installing grilles or duct and are not part of the installation, they are only used to help install the damper.

- 1 Solid wall construction/Gypsum wall construction
- 2 FDML
- 3 Mortar or gypsum/Ablative Coated Batt
- 4 L-profile - min. 30x30x3, length according to size of the installation opening (min. profile overlap 30 mm on each side) - L-profile is not part of the delivery
- 5 Nut M8 with anchor - Solid wall construction or Screw with hexagon head - Gypsum wall construction
- 6 Bolt M6x20 + large-area washer

In solid ceiling construction - mortar or gypsum

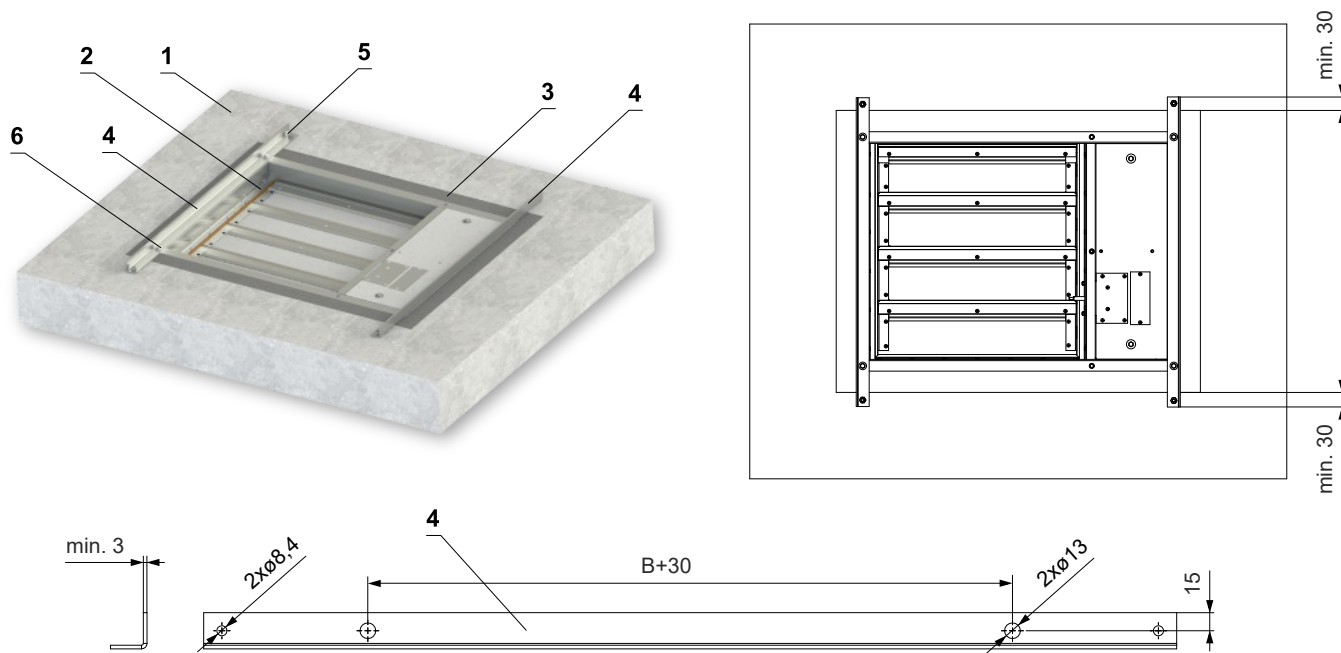

- Screw two L-profiles to the damper using M6x20 screws + washers and fix the L-profiles to the ceiling using M8 anchors and nuts. Fill the gap between the damper and the ceiling with mortar or gypsum. L-profiles must be removed before installing grilles or duct and are not part of the installation, they are only used to help install the damper.

- 1 Solid ceiling construction
- 2 FDML
- 3 Mortar or gypsum
- 4 L-profile - min. 30x30x3, length according to size of the installation opening (min. profile overlap 30 mm on each side) - L-profile is not part of the delivery
- 5 Nut M8 with anchor
- 6 Bolt M6x20 + large-area washer

In solid wall construction - mortar or gypsum/Ablative Coated Batt

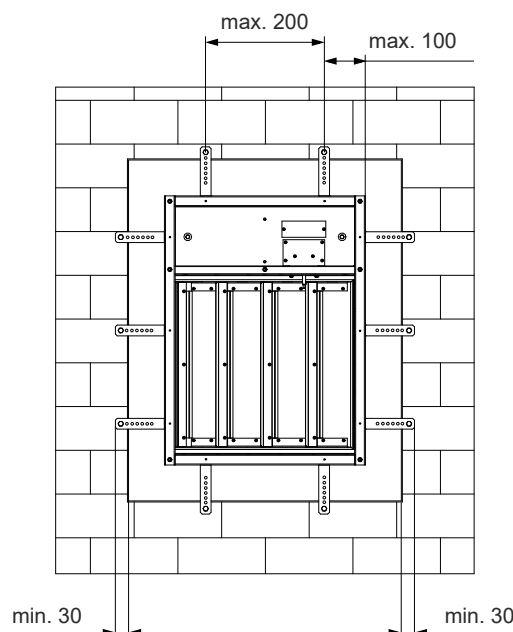
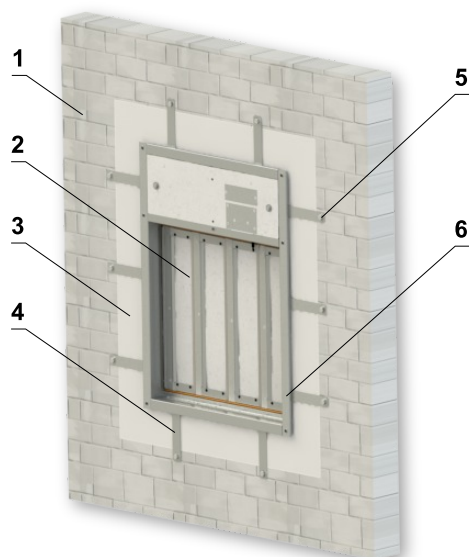

In gypsum wall construction - mortar or gypsum/Ablative Coated Batt

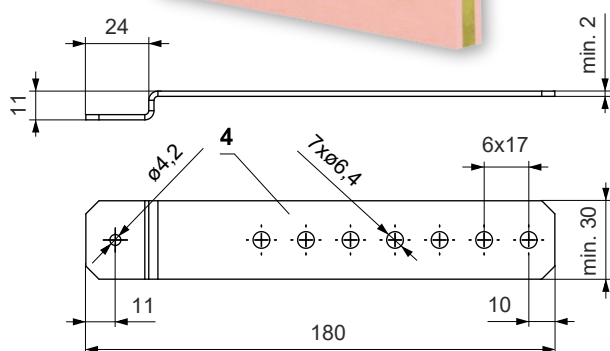
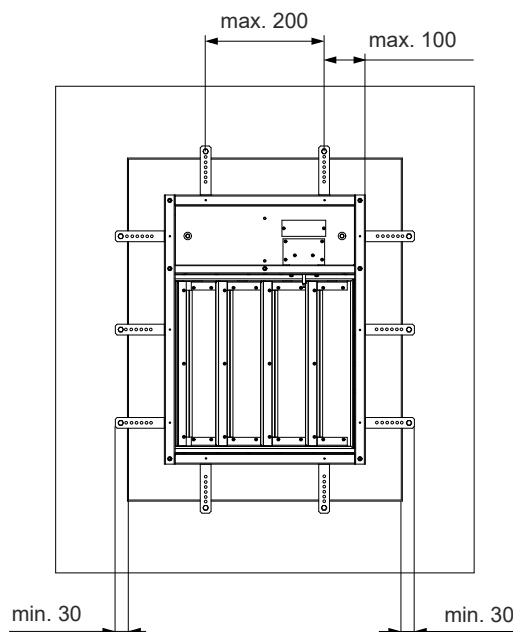
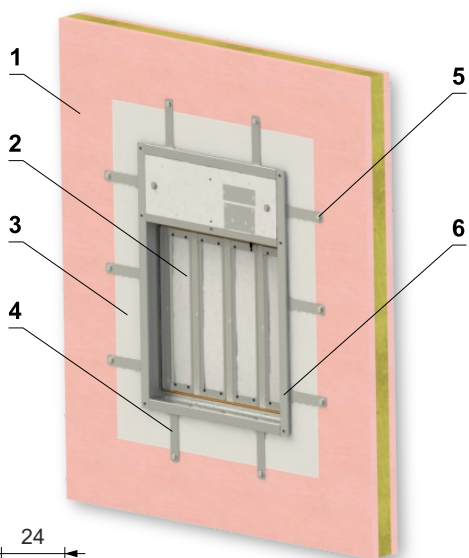

- Drill holes for rivets in the damper flange and rivet the damper holders. There must be at least 2 holders on each side of the damper with a maximum spacing of 200 mm and a maximum distance from the edge of the damper of 100 mm. Fix the holders to the wall using M6 anchors and nuts (solid wall construction) or screws (gypsum wall construction - screws must go through a gypsum profile). Fill the gap between the damper and the wall with approved material. The holders cannot be removed afterwards and will remain as a part of the installation. Install grilles or duct on the damper.

- 1 Solid wall construction/Gypsum wall construction
- 2 FDML
- 3 Mortar or gypsum/Ablative Coated Batt
- 4 Damper holder - holders can be ordered from Mandík a.s. or custom-made according to the required dimensions of the installation opening (min. width 30 mm, min. thickness 2 mm and min. overlap of holders 30 mm)
- 5 Nut M6 with anchor - Solid wall construction or Screw with hexagon head - Gypsum wall construction
- 6 Rivet 4x6

Example of duct connection

- The air duct is not connected to the damper in the entire cross-section of the damper, but only through the area of the damper with blades. The actuator cover must be accessible from at least one side. It is recommended that the cover be accessible from the side where the thermoelectric activation device cover is located for easy access.

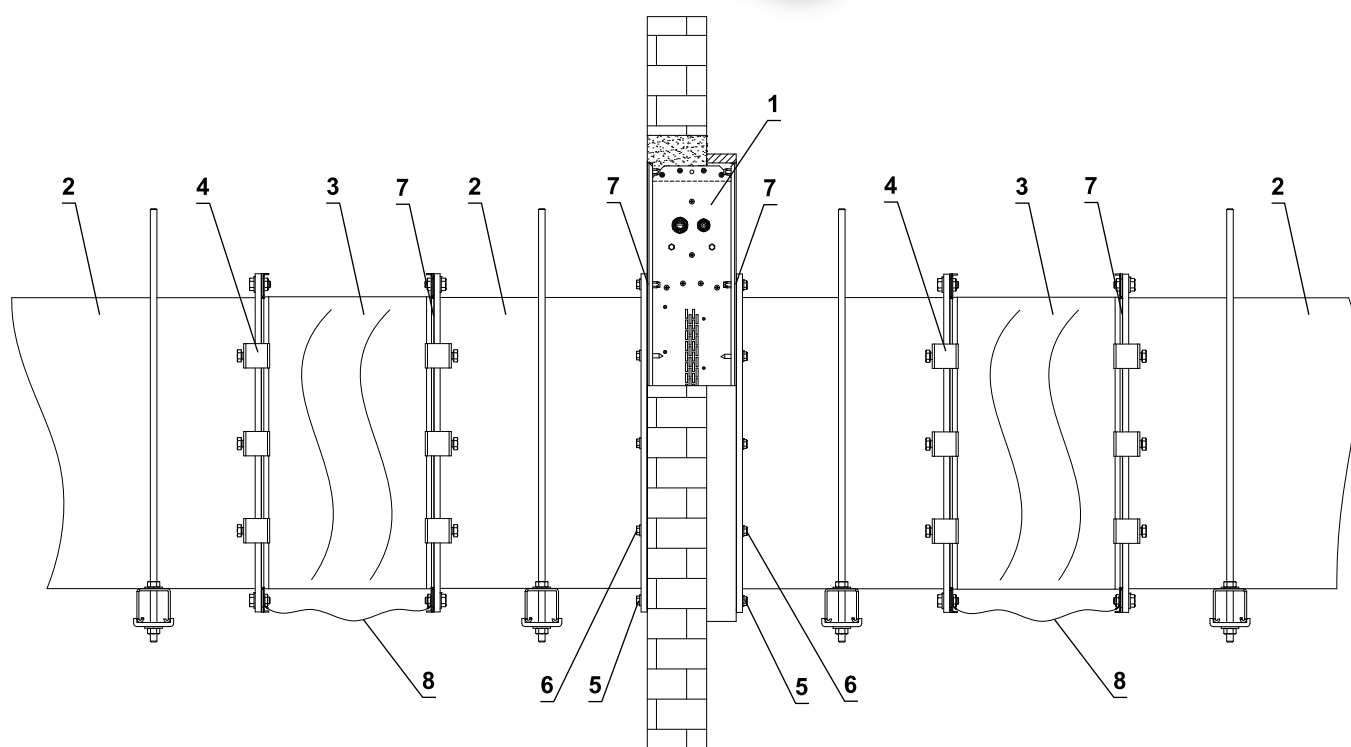
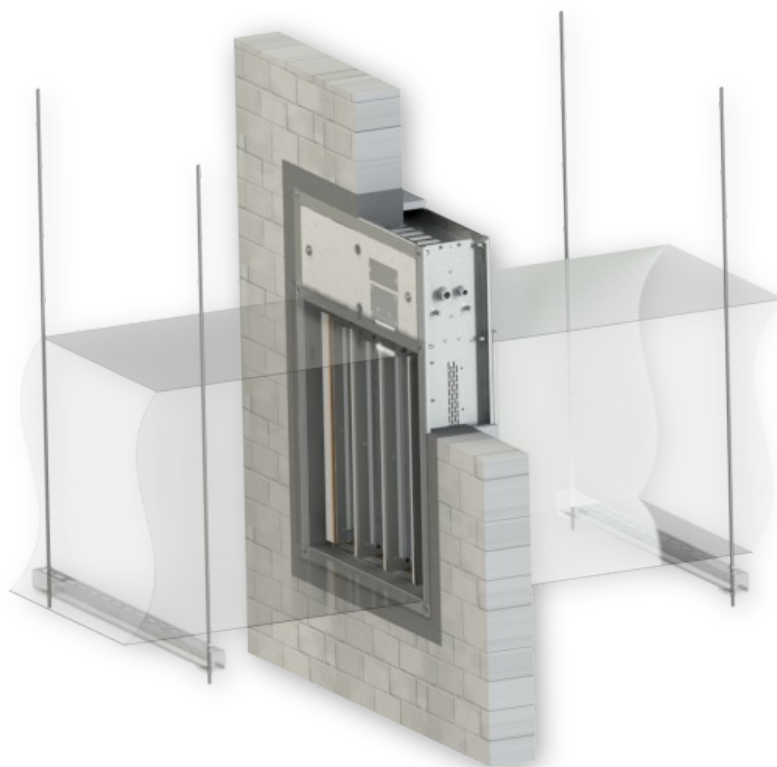

- 1 FDML
- 2 Duct
- 3 Damping pad
- 4 Steel clamp min. screw M8
- 5 Screws M6 in corners (more about connecting dimensions → see page 11)
- 6 Self-drilling screw - connection of the flanges of the damper and the duct
- 7 Sealing
- 8 Protective bonding conductor

V. TECHNICAL DATA

Pressure loss

Pressure loss calculation

$$\Delta p = \xi \cdot \rho \cdot \frac{w^2}{2}$$

Δp	[Pa]	pressure loss
w	[m/s]	air flow speed in nominal damper section
ρ	[kg/m ³]	air density
ξ	[-]	coefficient of local pressure loss for the nominal damper section → see page 29

Determination of pressure loss by using diagram $\rho = 1,2 \text{ kg/m}^3$

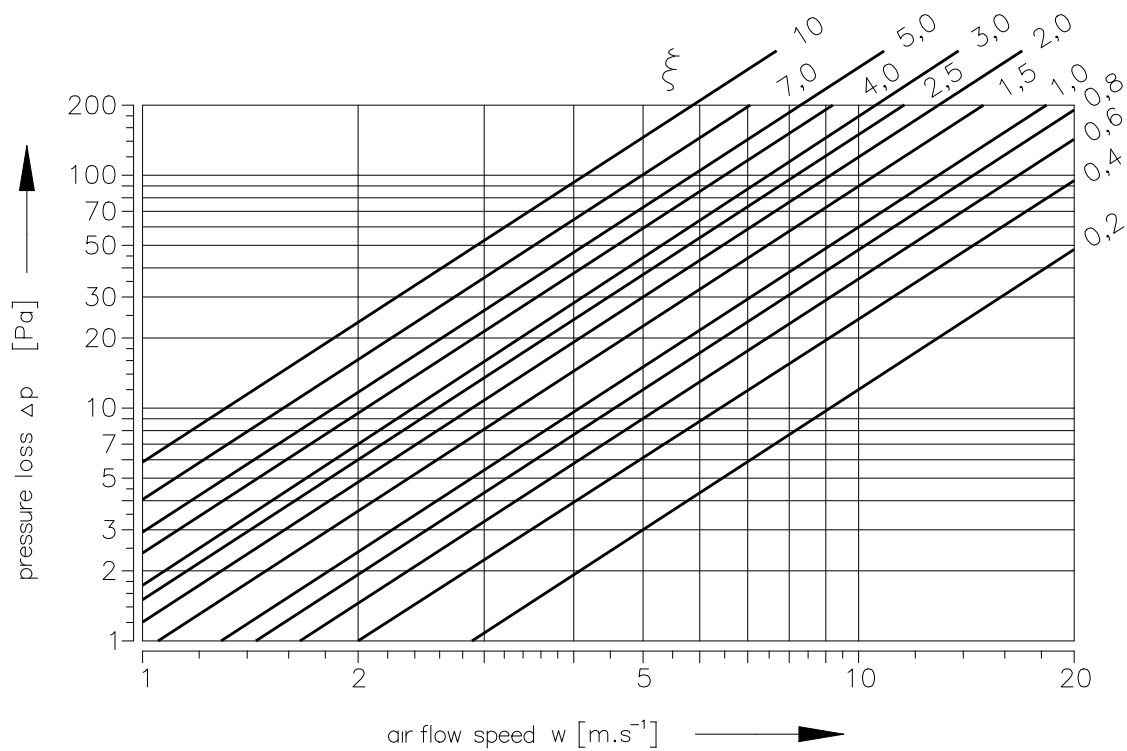

Coefficient of local pressure loss

	A									
B	200	250	280	300	315	355	400	450	500	560
300	4,185	4,069	4,000	3,954	3,919	3,827	3,723	3,608	3,492	3,354
315	4,347	4,226	4,154	4,106	4,070	3,974	3,865	3,745	3,625	3,480
355	3,660	3,543	3,472	3,426	3,390	3,297	3,191	3,074	2,957	2,816
400	2,828	2,742	2,690	2,656	2,630	2,561	2,484	2,397	2,311	2,208
450	3,803	3,689	3,622	3,576	3,542	3,452	3,350	3,236	3,123	2,987
500	2,866	2,791	2,747	2,717	2,694	2,635	2,567	2,493	2,418	2,329
560	3,391	3,286	3,223	3,181	3,149	3,065	2,971	2,866	2,761	2,634
600	3,169	3,073	3,015	2,976	2,947	2,869	2,782	2,685	2,589	2,472
630	2,721	2,644	2,597	2,566	2,543	2,481	2,412	2,335	2,258	2,165
650	2,661	2,578	2,527	2,494	2,469	2,402	2,326	2,243	2,159	2,059
700	3,195	3,099	3,042	3,004	2,975	2,898	2,812	2,716	2,620	2,505
710	3,012	2,924	2,871	2,836	2,809	2,739	2,659	2,571	2,483	2,377
750	2,652	2,574	2,527	2,495	2,472	2,409	2,339	2,260	2,182	2,088
800	2,741	2,664	2,617	2,586	2,563	2,501	2,431	2,354	2,276	2,183
850	2,647	2,573	2,528	2,498	2,476	2,417	2,350	2,275	2,201	2,112
900	2,344	2,276	2,236	2,209	2,188	2,134	2,073	2,006	1,938	1,857
950	2,777	2,699	2,652	2,621	2,597	2,535	2,465	2,387	2,309	2,215
1000	2,616	2,538	2,491	2,459	2,436	2,373	2,302	2,223	2,145	2,050

	A										
B	600	630	650	700	710	750	800	850	900	950	1000
300	3,261	3,192	3,146	3,031	3,007	2,915	2,800	2,684	2,569	2,453	2,338
315	3,384	3,312	3,264	3,144	3,119	3,023	2,903	2,783	2,662	2,542	2,422
355	2,722	2,652	2,605	2,488	2,464	2,370	2,253	2,136	2,019	1,901	1,784
400	2,139	2,087	2,053	1,967	1,949	1,880	1,794	1,708	1,622	1,536	1,450
450	2,897	2,829	2,783	2,670	2,648	2,557	2,444	2,330	2,217	2,104	1,991
500	2,269	2,224	2,194	2,119	2,105	2,045	1,970	1,896	1,821	1,746	1,672
560	2,550	2,487	2,445	2,340	2,319	2,235	2,130	2,025	1,920	1,815	1,710
600	2,395	2,337	2,298	2,201	2,182	2,105	2,008	1,911	1,814	1,717	1,621
630	2,103	2,057	2,026	1,949	1,933	1,871	1,794	1,717	1,640	1,563	1,485
650	1,992	1,941	1,908	1,824	1,808	1,741	1,657	1,573	1,489	1,406	1,322
700	2,429	2,371	2,333	2,237	2,218	2,141	2,045	1,949	1,853	1,758	1,662
710	2,306	2,254	2,218	2,130	2,112	2,042	1,954	1,865	1,777	1,689	1,601
750	2,025	1,978	1,947	1,869	1,853	1,790	1,712	1,634	1,555	1,477	1,399
800	2,121	2,075	2,044	1,967	1,951	1,889	1,812	1,734	1,657	1,579	1,502
850	2,052	2,008	1,978	1,904	1,889	1,830	1,755	1,681	1,607	1,532	1,458
900	1,803	1,762	1,735	1,668	1,654	1,600	1,532	1,465	1,397	1,330	1,262
950	2,153	2,106	2,074	1,996	1,981	1,918	1,840	1,762	1,684	1,606	1,528
1000	1,987	1,940	1,909	1,830	1,814	1,751	1,673	1,594	1,516	1,437	1,358

VI. MATERIAL, FINISHING

- Damper casings are made from galvanized sheet metal without further surface treatment.
- Cover grilles are made of sheet metal and coated with RAL 9010 burning varnish. Requests for other colours must be discussed in advance with the manufacturer.
- Damper blades are made from fire resistant asbestos free boards made of mineral fibres.
- The cover housing for the actuator is covered with fire resistant asbestos free boards made of mineral fibres.
- Closing mechanism and fasteners are galvanized.
- Damper blades are made from boards of homogeneous material Promatect-H.
- Plastic, rubber and silicon components, sealants, foaming tapes, glass-ceramic seals, housings, brass bearings of the blades, actuators, and end switches are identical for all material variants of the dampers.
- Cover grilles are always made of common steel sheet metal with a burning varnish.
- The damper blades in the variant for chemical environments (Class A4) are always treated with a coating of chemically resistant Promat SR.
- Any other requirements for the design will be considered atypical and will be addressed on an individual basis.

VII. TRANSPORTATION, STORAGE AND WARRANTY

Logistic terms

- Dampers are delivered in bulk. As standard, the dampers are wrapped in plastic foil for protection during transport and must not be used for long-term storage. Temperature changes during transport can cause condensation of water inside the packaging and thereby cause corrosion of materials used in the dampers (e.g. white corrosion on zinc-coated items or mould on calcium silicate). Therefore, it is necessary to remove the transport packaging immediately after unloading to allow air to circulate around the product.
- The dampers must be stored in clean, dry, well ventilated and dust-free environment out of direct sunlight. Ensure protection against moisture and extreme temperatures (minimum temperature +5°C). The dampers must be protected against mechanical and accidental damage prior to installation.
- Another required packaging system should be approved and agreed by manufacturer. Packaging material is not returnable in case that another packaging system (material) is required and used and it is not included into final price of damper.
- Dampers are transported by box freight vehicles without direct weather impact, there must not occur any shocks and ambient temperature must not exceed +50°C. Dampers must be protected against impact when transported and manipulated. During transportation, the damper blades must be in the "CLOSED" position.
- Dampers must be stored indoor in environment without any aggressive vapours, gases or dust. Indoor temperature must be in the range from -30°C to +50°C and maximum relative humidity 95%.

Warranty

- The manufacturer provides a warranty of 24 months from the date of dispatch for the dampers.
- The warranty for fire dampers FDML, provided by the manufacturer, is completely void if actuating, closing and control devices are unprofessionally handled by untrained workers or if electric components, i.e. actuators, supply devices and thermoelectric activation devices are dismantled.
- The warranty is void if dampers are used for other purposes, devices and working conditions than those allowed by these technical conditions or if the dampers are mechanically damaged during handling.
- If the dampers are damaged by transport, a record must be written down with the forwarder at reception for later complaint.

VIII. ASSEMBLY, ATTENDANCE AND MAINTENANCE

- Assembly, maintenance and damper function check can be done only by qualified and trained person, i.e. "AUTHORIZED PERSON" according to the manufacturer documentation. All works done on the fire dampers must be done according international and local norms and laws.
- All effective safety standards and directives must be observed during damper assembly.
- To ensure reliable damper function it is necessary to avoid blocking the actuating mechanism and contact surfaces with collected dust, fibre and sticky materials and solvents.

Manual operation - actuator control without electric voltage

- A special wrench (part of the actuator) can be used to manually turn the damper blades to any position. When the wrench is turned in the direction of the arrow, the damper blades rotate to open position. As the blades rotation is stopped, in every position, the actuator will be locked. Unlocking is possible even manually as per instructions on the actuator, or by the activation of the supply voltage.
- If the actuator is manually locked, the damper blades will not close in the event of a fire after the activation of the thermoelectric activation device BAT. To restore correct damper operation, the actuator must be unlocked (manually or by applying power supply).

Installation / fixing the damper

- It is necessary to ground the damper casing before installation.
- The damper casing shall not be deformed in the course of bricking in.
- Once the damper is built in, the damper blades shall not grind on the damper casing during opening or closing.
- Dampers are not equipped with inspection openings. If these dampers are used as dampers for simple maintenance and revision they must be completed with connecting inspection part installed just behind the damper.

Commissioning and revisions

- Before putting the damper into operation, serviceability checks and functional tests must be carried out including testing of functionality of all electrical elements. After putting into operation these serviceability checks must be carried at least twice a year. If no defect is found during two subsequent serviceability checks, these checks can be carried out once a year.
- In case that dampers are found unable to serve for their function for any cause, it must be clearly marked. The operator is obliged to ensure that the damper is put into condition in which it is ready for function and meanwhile he is obliged to provide the fire protection by another appropriate way.
- Results of regular checks, imperfections found and allimportant facts connected with the damper function must be recorded in the "FIRE BOOK" and immediately reported to the operator.
- Before entering the dampers with actuator into operation after their assembly and by sequential checks. Check of blades rotation into the breakdown position "CLOSED" can be done after disconnecting the actuator supply (e.g. by pressing the test button at the thermoelectric activation device BAT or disconnecting the supply from ELECTRICAL FIRE SIGNALISATION). Check of blades rotation back into the "OPEN" position can be done after restoration of power supply (e.g. by releasing the test button or restoration of supply from ELECTRICAL FIRE SIGNALISATION). Without power supply, the damper can be operated manually and fixed in any required position. Release of the locking mechanism can be achieved manually or automatically by applying the supply voltage. It is recommended to provide periodical checks, maintenance and service actions on fire equipment by authorized persons. The authorized persons can be trained by producer, or by authorized distributor. All effective safety standards and directives must be observed during fire damper assembly.
- Visual inspection of proper damper installation, inner area of a damper, damper blades, contact surfaces and silicon seal.

Following checks must be carried out for all dampers

- Check the rotation of the blades to "CLOSED" failure position after disconnection the power supply of the actuator (e.g. by pressing the test button on the thermoelectric activation device BAT or by disconnection the power supply from electrical fire signalization). Check the rotation of the blades back to "OPEN" position by restoring the power supply to the actuator (e.g. by releasing the test button or by restoring the power supply from electrical fire signalization).

Following checks must be carried out for dampers with optical smoke detector

- The function checks of the optical smoke detector are to be carried out by employees of an authorized organization who have corresponding electrotechnical qualification and have been properly trained by the manufacturer. The function checks are to be carried out as a part of function checks of the fire dampers, at least 1x a year.
- For the function checks, the damper blades should be in "CLOSED" position with the fan off or with closed air regulation situated between the fan and the fire damper.

How to proceed after Tf1 or Tf2 fuses have been activated

- If the thermal fuse **Tf1** is interrupted (due to temperature outside the duct), it is necessary to replace the spring return actuator. → see page 8.
- If the thermal fuse **Tf2** is interrupted (due to temperature inside the duct), only the spare part ZBAT 72 (95/120/140) needs to be replaced (acc.to the activation temperature). → see page 8

IX. ORDERING INFORMATIONS

Ordering key

Fire damper

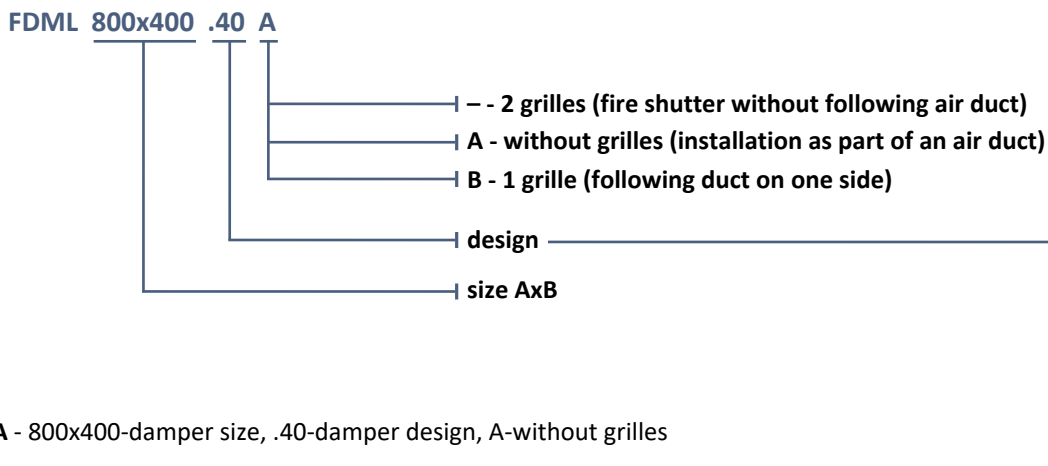

EXAMPLE:

FDML 800x400 .40 A - 800x400-damper size, .40-damper design, A-without grilles

Damper design	Additional digit
With actuator BF 230-TN (BFL, BFN 230-T) - voltage AC 230 V	.40
With actuator BF 24-TN (BFL, BFN 24-T), with smoke detector ORS 142 K and with supply device ZNP-10-24 (voltage 230 V AC)*	.41
With actuator BF 24-TN (BFL, BFN 24-T) - voltage AC/DC 24 V	.50
With actuator BF 24-TN (BFL, BFN 24-T), with smoke detector ORS 142 K (voltage 24V DC)*	.51

* Optical smoke detectors ORS 142K and power supply unit ZPN-10-24 are delivered in bulk

Data label

- Data label is placed on the damper casing (example)

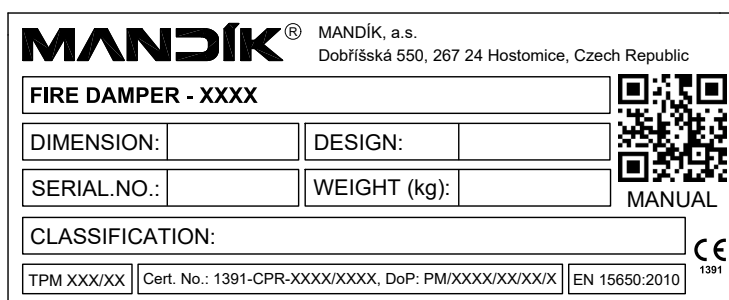

The producer reserves the right for innovations of the product.
For actual product information see www.mandik.com

MANDÍK[®]
www.mandik.com