

MANDÍK®

COVERING/PROTECTION GRILLE

KMM



These technical specifications state a row of manufactured sizes and models of covering/protection grilles (further only grilles) KMM. It is valid for production, designing, ordering, delivery, assembly and operation.

I. CONTENT

II. GENERAL INFORMATION	3
1. Description.....	3
2. Design.....	3
3. Dimestions and weights.....	4
III. TECHNICAL DATA	5
4. Basic parameters.....	5
IV. MATERIAL, FINISHING	5
5. Material.....	5
V. PACKING, TRANSPORTATION, TAKE-OVER, STORAGE AND GUARANTEE	5
6. Logistic terms.....	5
7. Guarantee.....	5
VI. ORDERING INFORMATION	6
8. Ordering key.....	6

II. GENERAL INFORMATION

1. Description

- 1.1. Grilles are used to cover side holes and free ends of piping, or to be fitted into the wall. Grilles prevent passing larger objects.
Grilles are fixed to side holes or free ends of duct with screws 6.3 x 16 according to EN ISO 1481. Free ends of duct are adapted by notching in corners up to length of "C" and bending. Corners remain free. Notching, bending, cutting the side holes out, boring, and fitting the grill is made during assembly.
- 1.2. Grilles with frame for fitting to the wall are supplied as a unit.
- 1.3. Grilles are designed for macroclimatic areas with mild climate according to EN 60 721-3-3 zm.A2. Grilles are suitable for systems without abrasive, chemical and adhesive particles.
If is not noticed other way, all dimensions and weight are in millimeters and kilograms.

2. Design

- 2.1. Grilles consist of a flange, panel made of tensile metal, and frame for fitting to wall if required. Dimensions A = 800 and higher have grilles provided with a central stiffening belt.
- 2.2. Design of grilles by location is marked by first supplementary number next to dash in the ordering key.
- 2.2. Design of grilles by location
Marked by first supplementary number next to dash in the ordering key.

Tab. 2.2.1. Design of grilles by location

Design	Location	First supplementary number
grilles with flanges	to sides of piping or free ends of piping	.2
grilles with flanges, frame and holders		.3

- 2.3. Design of grilles by surface painting
Marked by second supplementary number next to dash in the ordering key.

Tab. 2.3.1. Design of grilles by surface painting

Design	Second supplementary number	
Surface treatment by painting	- ground coat	.x0
	- RAL 9010 - shade - white	.x1
	- RAL 9001 - shade - cream	.x2
	- RAL 9006 - shade - aluminium	.x3
AtyFigal shade - agreement with the manufacturer	.x9	

- 2.4. Detail of mounting

Fig. 1 Detail of mounting

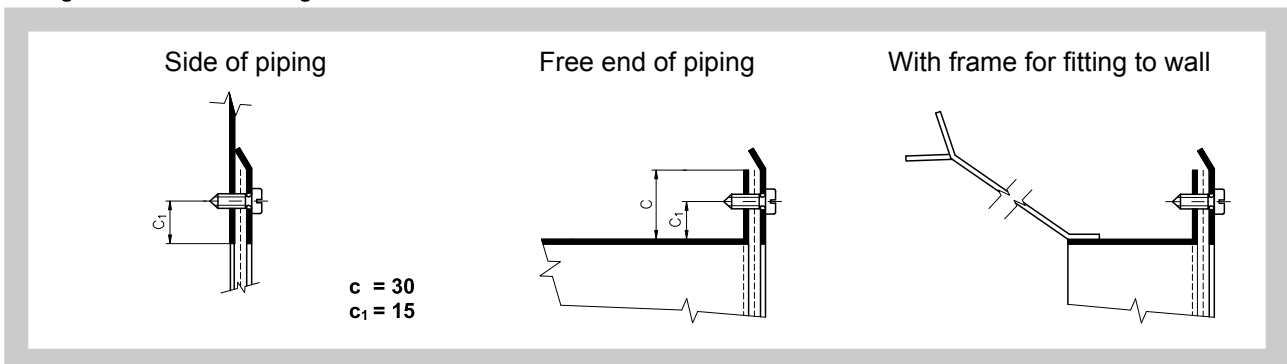

3. Dimestions and weights

Fig. 2 Dimensional diagram

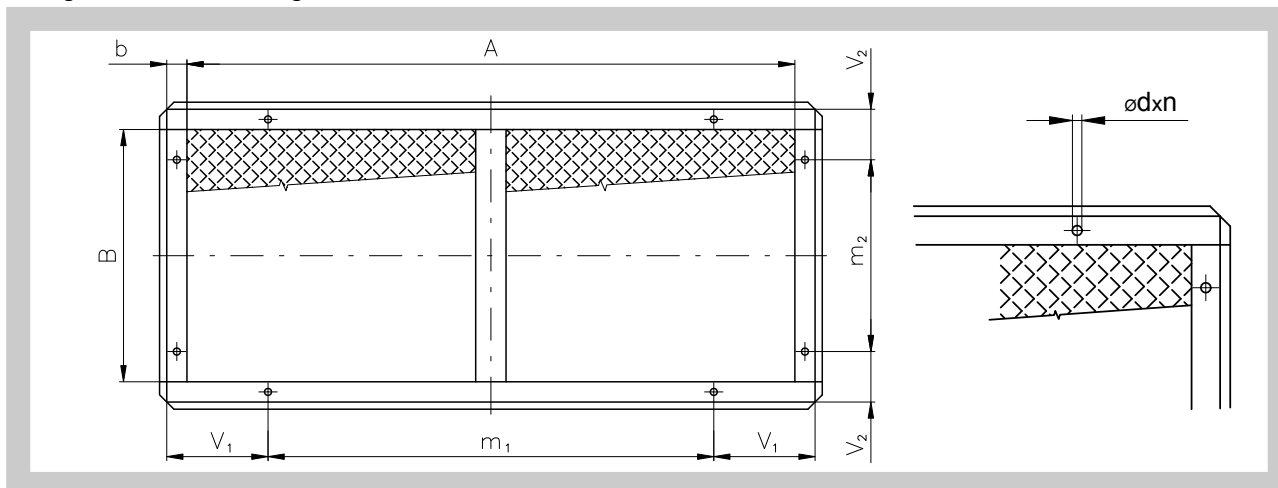

Tab. 3.1.1. Dimestions and weights

A x B	V ₁	m ₁	V ₂	m ₂	b	d	n	Holders pcs.	Weigth				
									Design				
									.2	.3			
125 x 125	92,5	-	92,5	-	30	7	4	2	0,30	0,80			
160 x 125	110	-	92,5	-					6	2	0,35	0,90	
x 160			110								0,40	1,00	
200 x 125	130	-	92,5	-						8	2	0,40	1,00
x 160			110									0,45	1,10
x 200			130									0,50	1,25
250 x 125	60	190	92,5	-				6		2	0,45	1,15	
x 160			110						0,50		1,25		
x 200			130						0,60		1,30		
x 250			60						190		0,65	1,55	
315 x 125	60	255	92,5	-				6	2	0,60	1,60		
x 160			110							0,70	1,65		
x 200			130				0,75			1,80			
x 250			60				190			0,80	1,90		
x 315			60				255			0,95	2,15		
400 x 160	110	240	110	-			6	4	0,80	1,90			
x 200			130						0,90	2,10			
x 250			60						190	0,95	2,15		
x 315			60				255		1,10	2,45			
x 400			110				240		1,30	2,80			
500 x 200			110				170		130	-	8	4	1,10
x 250	60	190		1,25				2,75					
x 315	60	225		1,35				2,95					
x 400	110	240		1,40				3,05					
x 500	110	170		1,60				3,50					
630 x 250	110	235		60				-	10		4		1,35
x 315			60	225			1,45			3,10			
x 400			110	240			1,65			3,50			
x 500			110	170			1,80		4,00				
x 630			110	235			2,30		4,50				
800 x 315			110	320	60	-	10		4	2,40		5,50	
x 400	60	240			2,70			6,00					
x 500	60	170			2,80			6,50					
x 630	110	235			3,00		7,00						
x 800	110	320			3,50		8,00						
1000 x 400	110	420			60		-	10		6	2,90	6,50	
x 500			60	170	3,30	7,50							
x 630			60	235	3,60	8,00							
x 800			60	320	4,20	9,00							
1250 x 500			110	363	60	-		14	8		4,20	9,00	
x 630					60						235	4,50	9,50
x 800	60	320			4,90		10,50						
x 800	60	320			4,90		10,50						

If is required, we can supply all inter-dimensions of above given basic range.

III. TECHNICAL DATA

4. Basic parameters

4.1. Active surface area 78 %.

4.2. Coefficients of pressure losses:

Up to size A = 630	on inlet side -	$\xi = 2,2$
	on outlet side -	$\xi = 1,5$

From size A = 800	on inlet side -	$\xi = 2,4$
	on outlet side -	$\xi = 1,7$

4.3. Pressure loss calculation:

$$\Delta p = \xi \cdot \rho \cdot \frac{v^2}{2}$$

Δp [Pa] Pressure loss

v [m.s⁻¹] air flow speed in nominal grilles section

ρ [kg.m⁻³] Air density

ξ [-] coefficient of local pressure loss for the nominal grilles section

IV. MATERIAL, FINISHING

5. Material

5.1. The grille flanges and panels from tensile metal are made of material class 11 and coated according to Tab 2.3.1. Frames for fitting to the wall are provided only with a ground coat.

V. PACKING, TRANSPORTATION, TAKE-OVER, STORAGE AND GUARANTEE

6. Logistic terms

6.1. Grilles are supplied packed in shrink foil. While transported and stored they must be protected against mechanical damage and weather conditions.

6.2. If no method of take-over is mentioned in the order, handing the goods over to the carrier will be considered as a take-over.

6.3. Grilles have to be stored in covered buildings, in the environment without aggressive steams, gases and dusts.

7. Guarantee

7.1. The manufacturer provides a guarantee to the cover grilles for the period of 24 months from the date of shipment.

VI. ORDERING INFORMATION

8. Ordering key

KMM 400x400 - .23 TPM 002/96

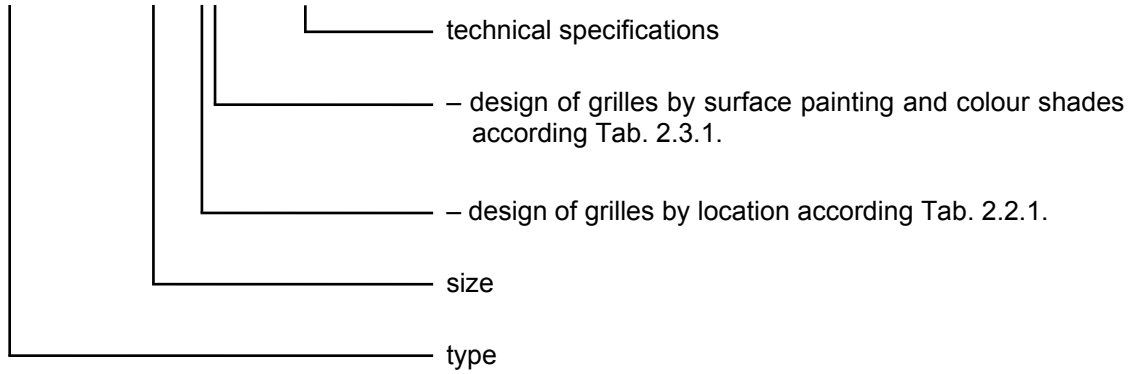

MANDÍK, a.s.
Dobříšská 550
26724 Hostomice
Czech Republic
Tel.: +420 311 706 706
E-Mail: mandik@mandik.cz
www.mandik.com

The producer reserves the right for innovations of the product. For actual product information see
www.mandik.com