

## CFDM and CFDM-V

### Fire damper

Technical Documentation

Installation, Commissioning, Operation, Maintenance and Service Manual

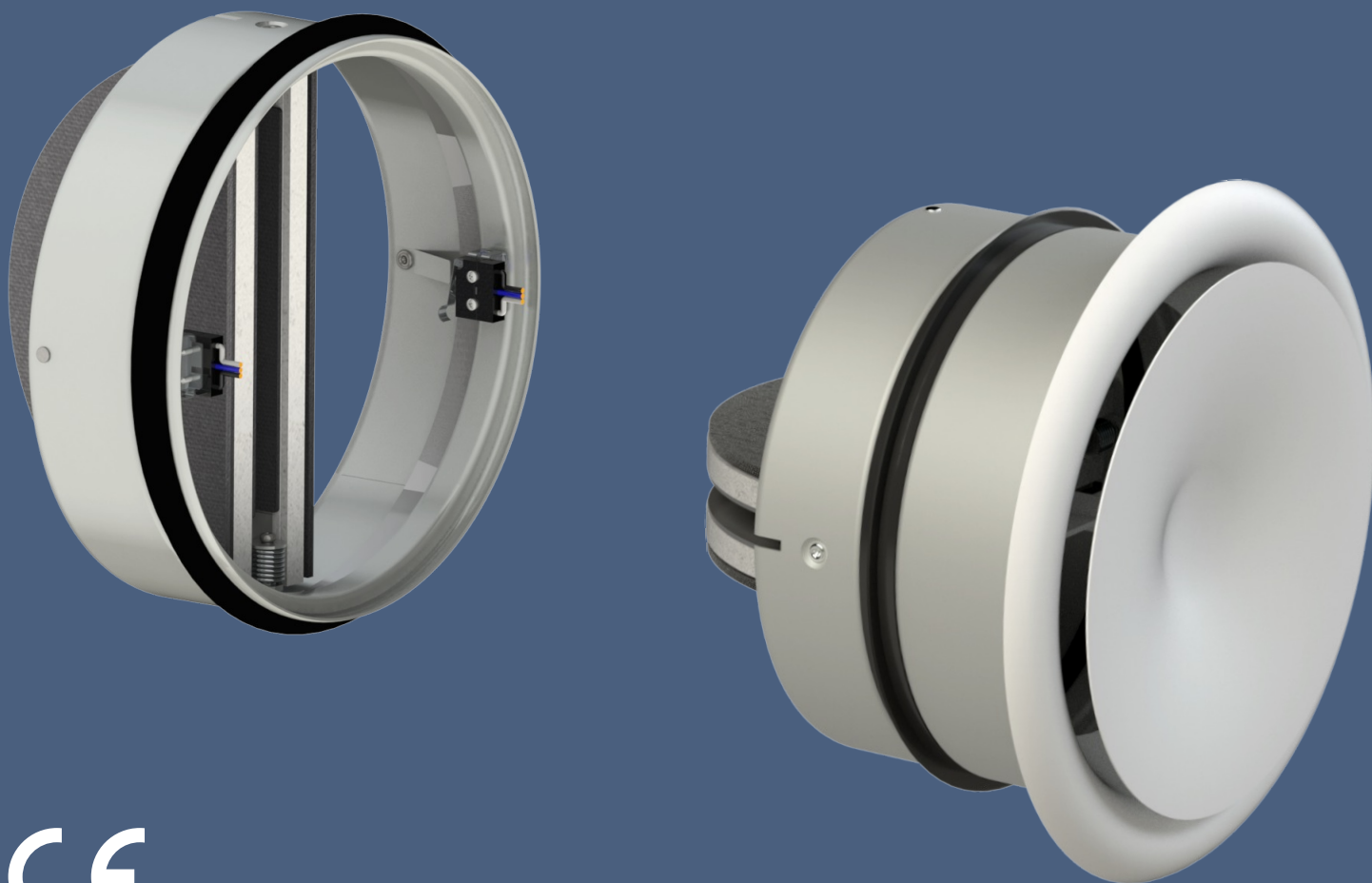

These technical specifications state a row of manufactured sizes and models of fire dampers CFDM and CFDM-V.  
It is valid for production, designing, ordering, delivery, maintenance and operation.

# CONTENT

I. GENERAL.....	3
Description.....	3
II. DESIGN.....	4
Design with mechanical control.....	4
III. DIMENSIONS.....	6
Technical parameters.....	6
IV. INSTALLATION.....	7
Placement and installation.....	7
Statement of installations.....	8
Installation in solid wall construction.....	9
Installation in gypsum wall construction.....	12
Installation in solid ceiling construction.....	15
Installation procedure of the CFDM / CFDM-V damper in the fire separation construction.....	16
V. TECHNICAL DATA.....	17
Pressure loss.....	17
VI. MATERIAL, FINISHING.....	18
VII. TRANSPORTATION, STORAGE AND WARRANTY.....	18
Logistic terms.....	18
Warranty.....	18
VIII. ASSEMBLY, ATTENDANCE AND MAINTENANCE.....	19
Commissioning and revisions.....	19
IX. ORDERING INFORMATIONS.....	20
Ordering key.....	20
Data label.....	21

# I. GENERAL

## Description

Fire dampers are shutters in ducts of air-conditioning devices that prevent the spread of fire and combustion products from one fire segment to the other one by means of closing the duct in the points of fire separating constructions.

Dampers blade automatically closes air duct using a closing spring. The closing spring is activated by the thermal fuse. The spring closes the damper blades.

After closing the blade, the damper is sealed with a plastic foam packing against smoke penetration. In the closed

position, the damper is also sealed with material which increases its volume due to increasing temperature and air proofs the air duct.

Fire damper can be directly equipped with the dish valve in both combinations - exhaust valve (TVOM) and supply valve (TVPM). The valve is fixed in the damper body by springs and can be easily put out from the damper. The dish valve can only be installed on a damper with an extended casing (CFDM-V).



CFDM

CFDM-V with exhaust valve (TVOM) and supply valve (TVPM)

### Damper characteristics

- CE certified acc. to EN 15650
- Tested in accordance with EN 1366-2
- Classified acc. to EN 13501-3+A1
- Damper design according to required fire resistance: EI 60 S, EI 90 S, EI 120 S
- Internal leakage class 2 acc. to EN 1751, external leakage is equal to ducting system
- Corrosion resistant acc. to EN 15650
- Certificate of constancy of performance No. 1391-CPR-XXXX/XXXX
- Declaration of Performance No. PM/CFDM/01/XX/X, PM/CFDM-V/01/XX/X
- Hygienic assessment of fire dampers - Report No. 1.6/pos/19/19b

### Working conditions

- Exact damper function is provided under the following conditions:
  - maximum air velocity 12 m/s
  - maximum pressure difference 1200 Pa
  - the air circulation in the whole damper section must be secured steady over the entire surface.
- Dampers can be installed in arbitrary position
- Dampers are suitable for systems without abrasive, chemical and adhesive particles.
- Dampers are designed for macroclimatic areas with mild climate according to EN IEC 60 721-3-3 ed.2., class 3K22. (Environment 3K22 is typically protected place with regulated temperature)
- Temperature in the place of installation is permitted to range from -30°C to +50°C.

## II. DESIGN

### Design with mechanical control

#### Design .01

- Design with manual control with a thermal fuse which actuates the shutting device, after the nominal activation temperature 72°C has been reached.
- Automatic initiation of the manual control is not activated if the temperature does not exceed 70°C.
- Damper design according to required fire resistance: EI 60 S, EI 90 S, EI 120 S



Design .01 - CFDM



Design .01 - CFDM-V with dish valve

#### Design .11 and .15

- Design .01 with manual control can be complemented with a limit switch signaling of the damper blade position "CLOSED".
- Design .11 - 1 limit switch "CLOSED".
- Design .15 - 2 limit switches "CLOSED".
- Connection wires of the end-switches of CFDM fire dampers are done through the bushing opening in the air-duct. In the case of CFDM-V dampers, it is possible to connect the end-switches appropriately around the valve or through the hole in the body air-duct and in the construction.
- Damper design according to required fire resistance: EI 60 S, EI 90 S, EI 120 S
- Limit switch detail → see page 5



Design .11



Design .15

Limit switch G905-300E03W1

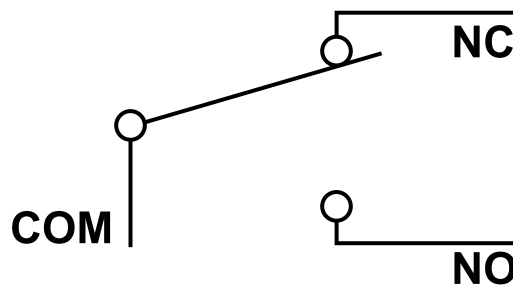
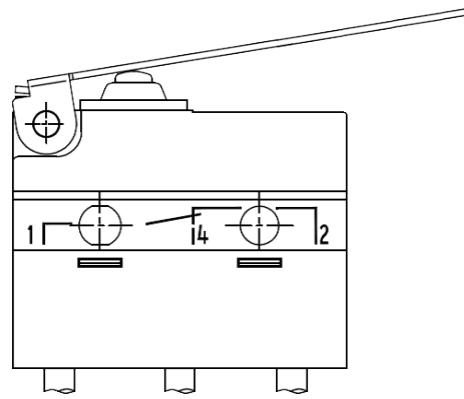

1(COM) - black wire  
 2(NC) - gray wire  
 4(NO) - blue wire

Nominal voltage and maximal current	AC 230V / 5A
Class of protection	IP 67
Working temperature	-25°C ... +120°C

This limit switch is possible to connect in two following ways

- CUT-OFF if the arm is moving ... connect wire 1+2
- SWITCH-ON if the arm is moving ... connect wire 1+4

### III. DIMENSIONS

#### CFDM

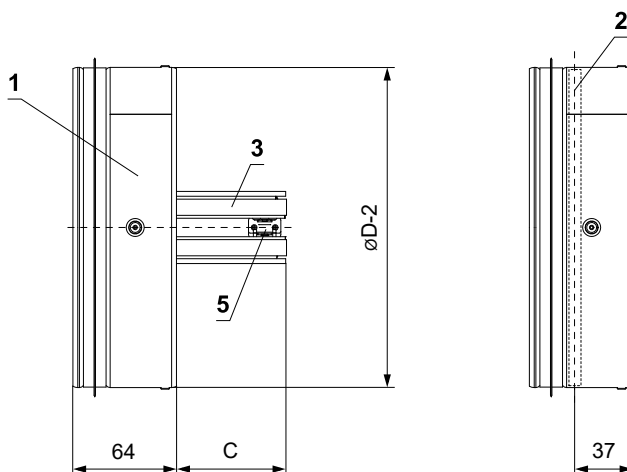
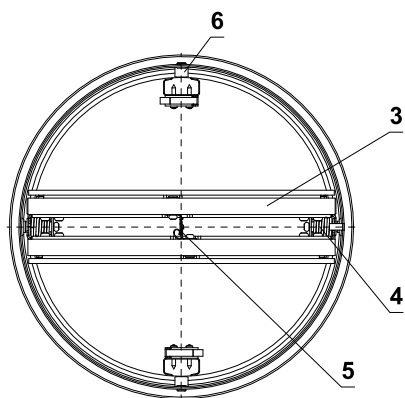

- 1 Damper casing CFDM
- 2 Blade axis of damper
- 3 Damper blade
- 4 Shutting spring
- 5 Thermal fuse
- 6 Locking planchet

#### CFDM-V with dish valve

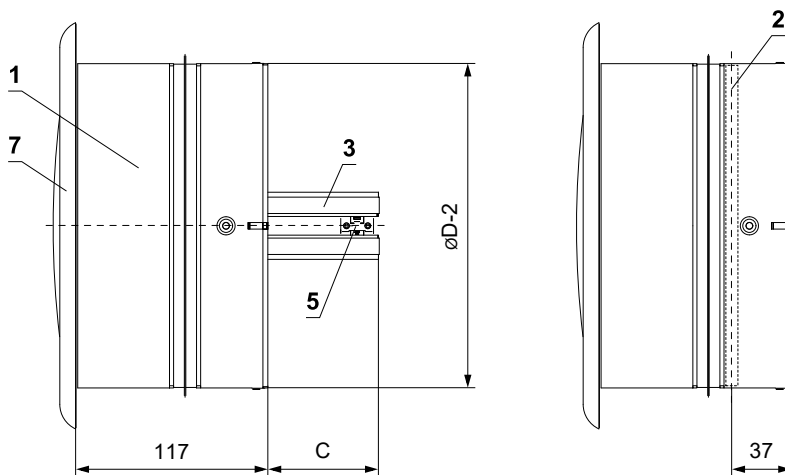
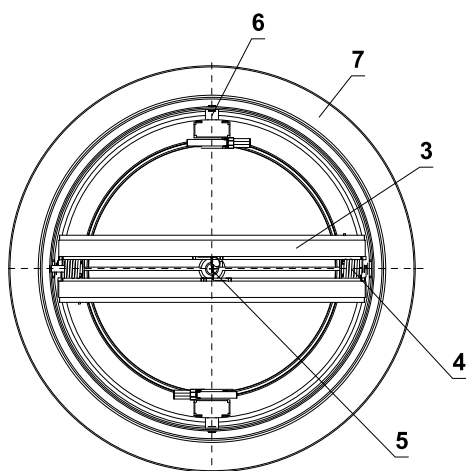

- 1 Damper casing CFDM-V
- 2 Blade axis of damper
- 3 Damper blade
- 4 Shutting spring
- 5 Thermal fuse
- 6 Locking planchet
- 7 Dish valve

### Technical parameters

Nominal size ØD [mm]	Weight CFDM [kg]	Weight CFDM-V * [kg]	Weight TVPM [kg]	Weight TVOM [kg]	Effective area Sef [m²]	Damper blade overlaps "c" [mm]
100	0,3	0,5	0,19	0,17	0,0030	18
125	0,4	0,6	0,27	0,23	0,0060	30
160	0,6	0,8	0,42	0,38	0,0119	48
200	0,8	1	0,59	0,51	0,0209	68

\* It is necessary to add the weight of selected dish valve to the CFDM-V (TVPM or TVOM).

## IV. INSTALLATION

### Placement and installation

- The fire dampers are suitable for installation in arbitrary position in vertical and horizontal passages of fire separating constructions. The damper installation procedures must be done so that all load transfer from the fire separating constructions to the damper is absolutely excluded. Following air-conditioning duct must be suspended or supported so that all load transfer from the following duct to the fire damper is absolutely excluded. The gap between the installed damper and the fire separating construction must be perfectly filled with approved material.
- Damper has to be accessible for regular checks and maintenance.
- Fire damper is inserted inside the duct. Blade has to be inside of fire separating construction (after closing).
- The distance between the fire damper and the construction (wall, ceiling) must be 75 mm at the minimum, according to EN 1366-2. If two or more dampers are to be installed in one fire separating construction, the distance between adjacent dampers must be 200 mm at the minimum, according to EN 1366-2. Other approved variants → see pages 9 to 15

#### Minimum distance between the fire dampers and the construction

- minimum distance 200 mm between dampers, according to EN 1366-2
- minimum distance 75 mm between damper and construction (wall/ceiling), according to EN 1366-2
- other approved variants → see pages 9 to 15

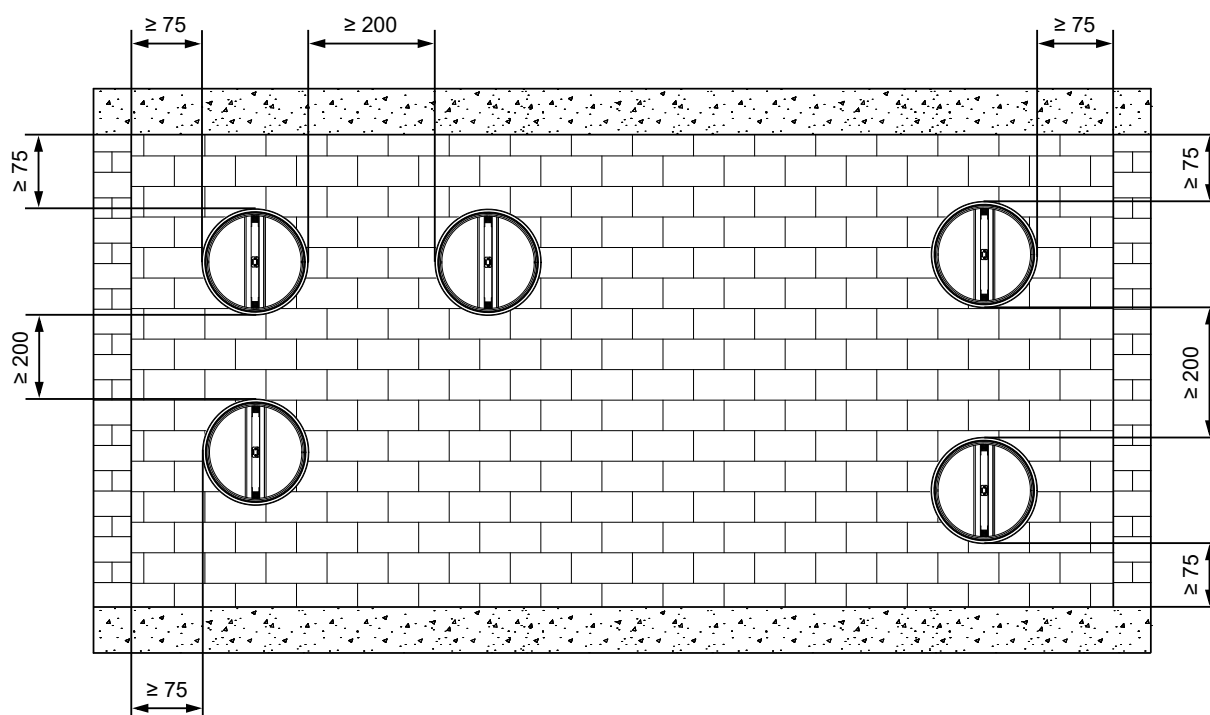

Dimensions of an installation opening

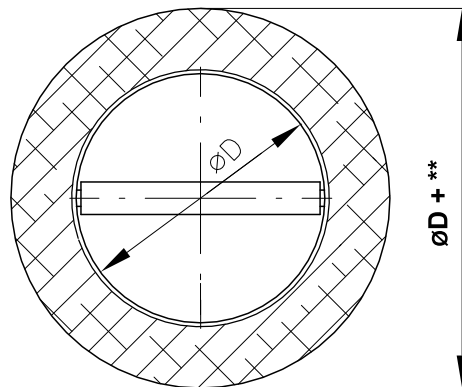
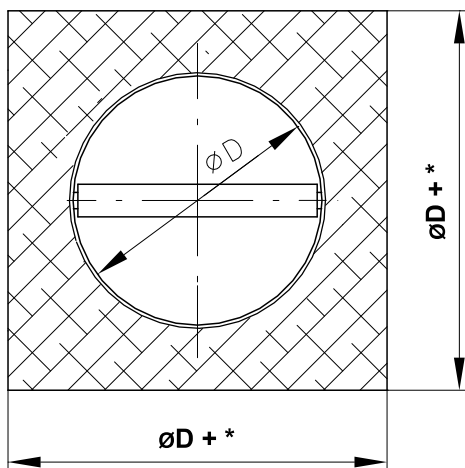

- \* Mortar or gypsum, damper CFDM 60 in solid/gypsum wall construction
  - min. ØD+60
  - max. ØD+240
- \* Mortar or gypsum, damper CFDM 90/120 in solid/gypsum wall construction
  - ØD+100
- \* Ablative Coated Batt, damper CFDM 90 in solid/gypsum wall construction
  - ØD+100
- \* Mortar or gypsum, damper CFDM 60/90 in ceiling construction
  - ØD+100

- \*\* Mortar or gypsum, damper CFDM 60 in solid wall construction (round opening)
  - min. ØD+60
  - max. ØD+240
- \*\* Mortar or gypsum, damper CFDM 90/120 in solid wall construction (round opening)
  - ØD+100

Statement of installations

Installation	wall/ceiling min. thickness [mm]	Method of installation	Fire resistance *	Page
In solid wall construction	100	Mortar or gypsum	EI 60 (v <sub>e</sub> ) S [V/H] EI 90 (v <sub>e</sub> ) S [V/H]	9
	125		EI 120 (v <sub>e</sub> ) S [V/H]	
		Ablative Coated Batt	EI 90 (v <sub>e</sub> ) S [V/H]	10
	100	Up to 4 dampers in one installation opening - mortar or gypsum	EI 60 (v <sub>e</sub> ) S [V/H]	11
In gypsum wall construction	100	Mortar or gypsum	EI 60 (v <sub>e</sub> ) S [V/H] EI 90 (v <sub>e</sub> ) S [V/H]	12
	125		EI 120 (v <sub>e</sub> ) S [V/H]	
		Ablative Coated Batt	EI 90 (v <sub>e</sub> ) S [V/H]	13
	100	Up to 4 dampers in one installation opening - mortar or gypsum	EI 60 (v <sub>e</sub> ) S [V/H]	14
In solid ceiling construction	150	Mortar or gypsum	EI 60 (h <sub>o</sub> ) S [H] EI 90 (h <sub>o</sub> ) S [H]	15

\* Depending on the required fire resistance, it is necessary to use a damper type with the appropriate fire resistance.



### Installation in solid wall construction

#### In solid wall construction - mortar or gypsum

- Depending on the required fire resistance, it is necessary to use a damper type with the appropriate fire resistance.

\*EI 60 (v<sub>e</sub>) S [V/H]  
 EI 90 (v<sub>e</sub>) S [V/H]  
 EI 120 (v<sub>e</sub>) S [V/H]

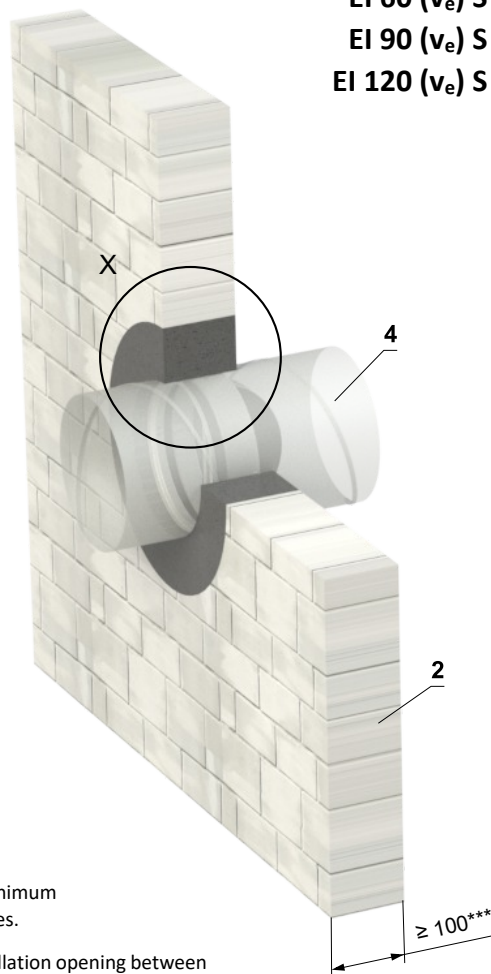
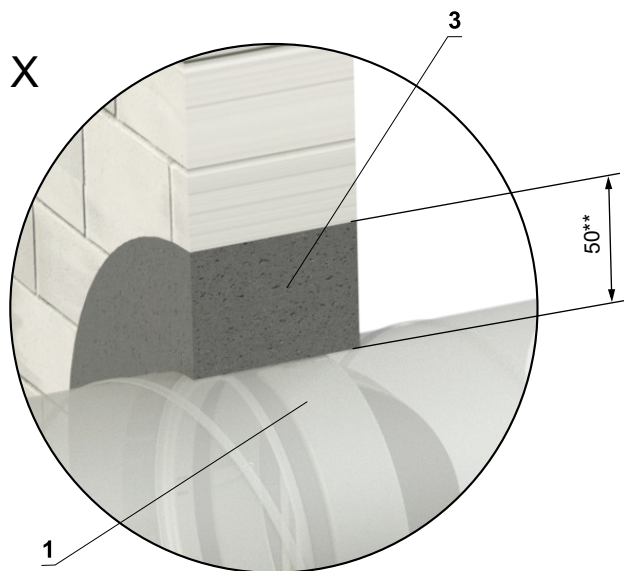

\* CFDM 60 dampers can be installed at a minimum distance of 30 mm from adjacent structures.

\*\* For damper CFDM 60, the approved installation opening between the construction and the damper is between 30...120 mm.

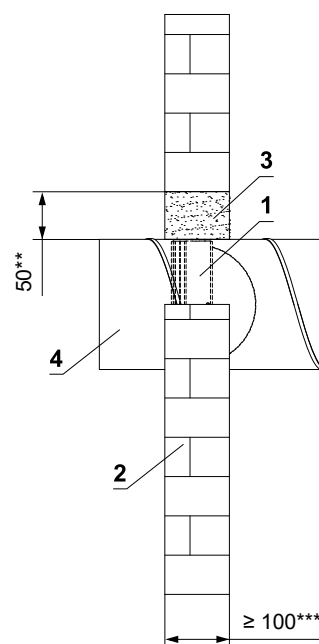
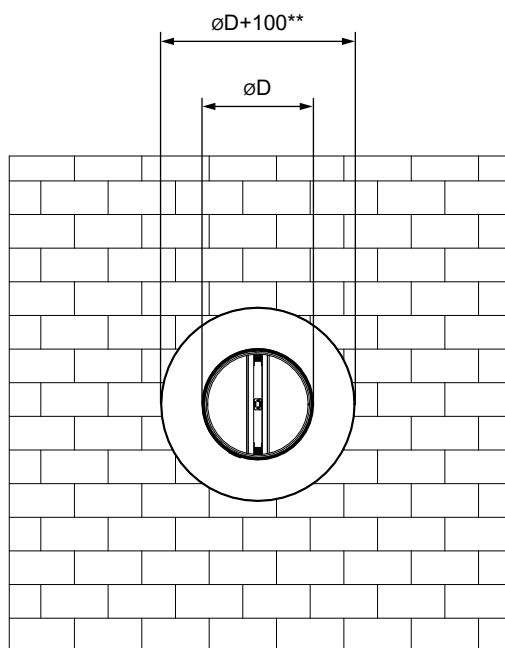

- 1 CFDM
- 2 Solid wall construction
- 3 Mortar or gypsum
- 4 Duct

\*\*\* ≥ 100 mm for dampers CFDM 60/90  
 ≥ 125 mm for damper CFDM 120

In solid wall construction - Ablative Coated Batt

EI 90 (ve) S [V/H]

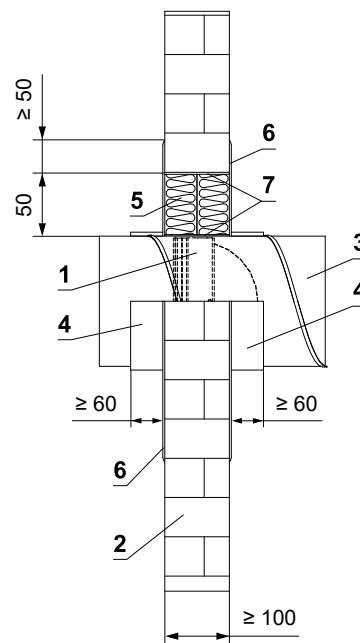
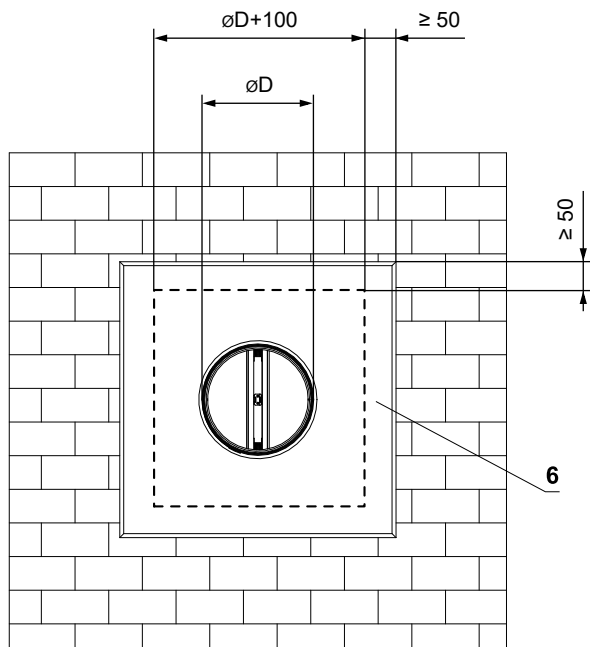
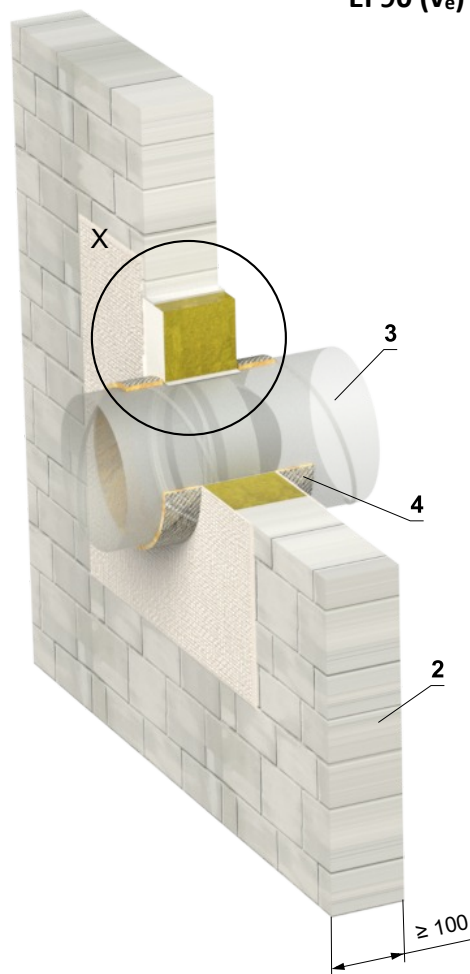
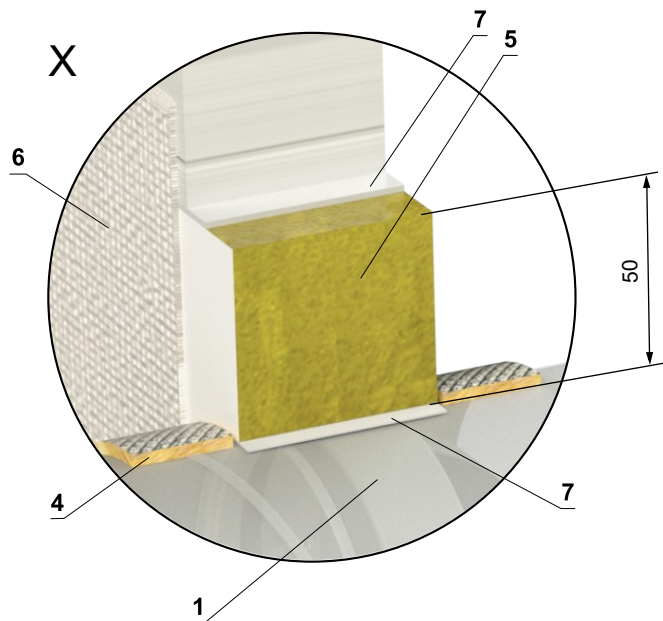

- 1 CFDM
- 2 Solid wall construction
- 3 Duct
- 4 Self-adhesive insulating tape, 6 mm thick, min. 60 mm wide (Kerafix 2000) - stick to the duct on both sides of the fire separation construction
- Ablative Coated Batt System HILTI\*
- 5 Mineral wool board - min. density 140 kg/m<sup>3</sup> (HILTI CFS-CT B 1S 140/50...)
- 6 Fire stop coating - th. 1 mm (HILTI CFS-CT...) - coating is overcoated on the support construction and on the duct.
- 7 Fire-resistant mastic - (HILTI CFS-S ACR...) fill the gap from both sides of the fire separation construction and around the perimeter of penetration and the duct.

\* HILTI system can be replaced by a similar system with the same or higher thickness, density, fire reaction class, tested according to EN 1366-3.

In solid wall construction - up to 4 dampers in one installation opening - mortar or gypsum

\*EI 60 (ve) S [V/H]

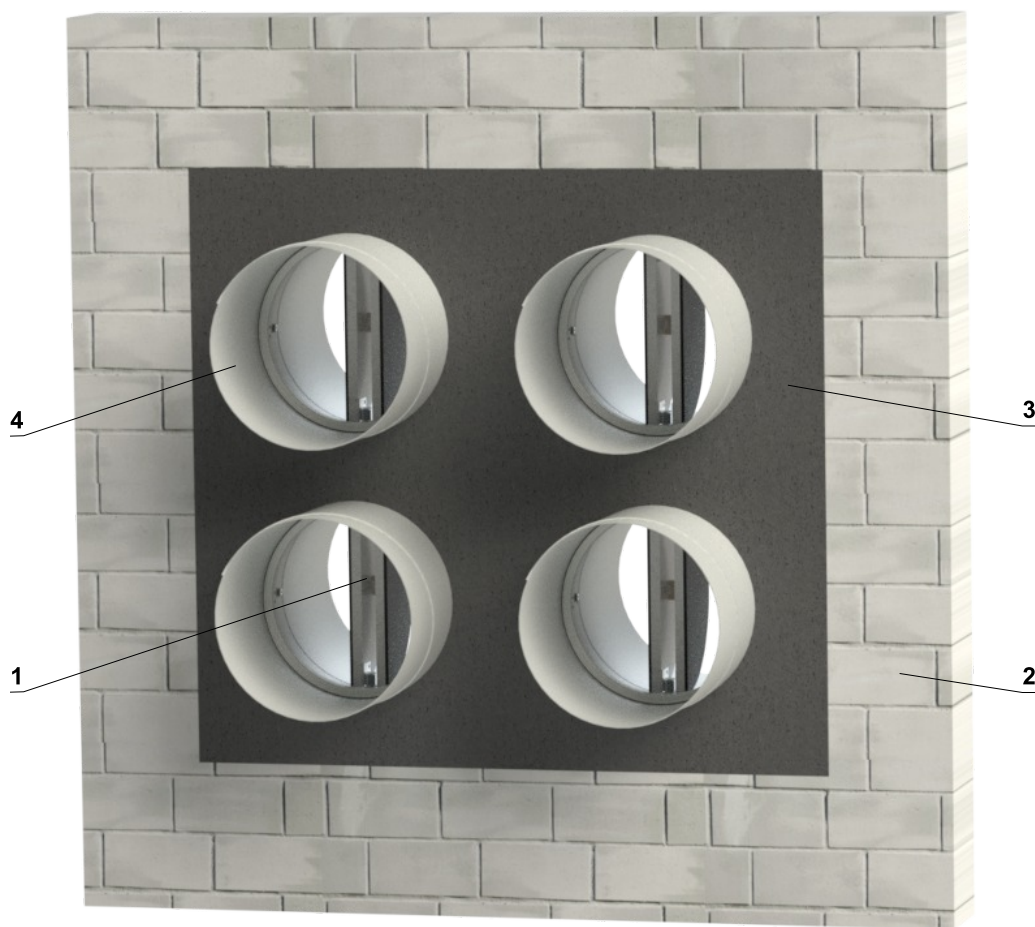

\* CFDM 60 dampers can be installed at a minimum distance of 30 mm from adjacent structures.

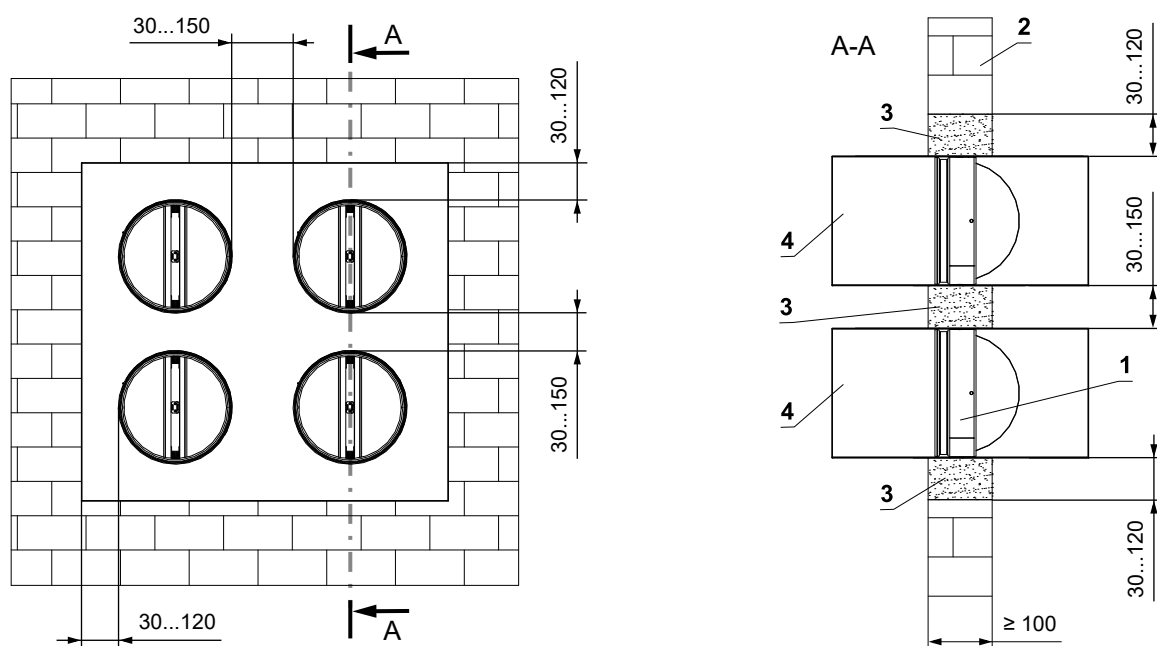

- 1 CFDM
- 2 Solid wall construction
- 3 Mortar or gypsum
- 4 Duct

### Installation in gypsum wall construction

#### In gypsum wall construction - mortar or gypsum

- Depending on the required fire resistance, it is necessary to use a damper type with the appropriate fire resistance.

\*EI 60 (v<sub>e</sub>) S [V/H]  
 EI 90 (v<sub>e</sub>) S [V/H]  
 EI 120 (v<sub>e</sub>) S [V/H]

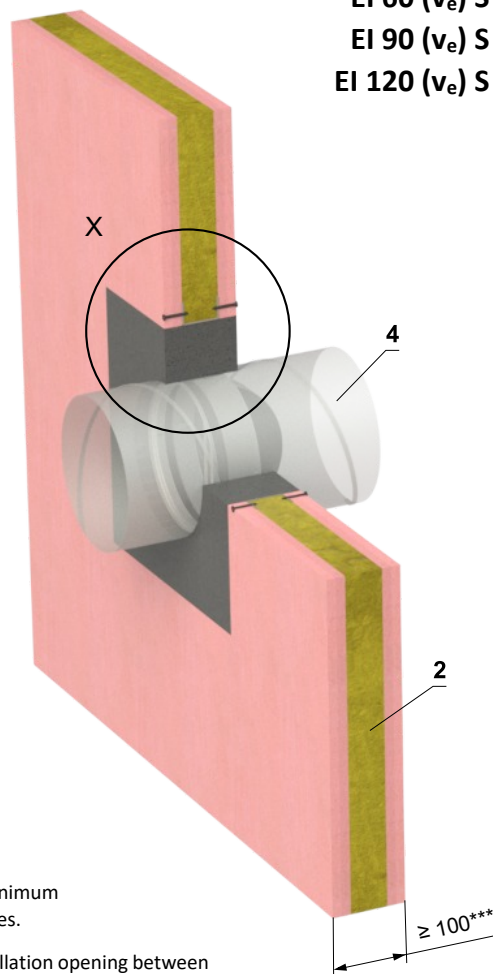
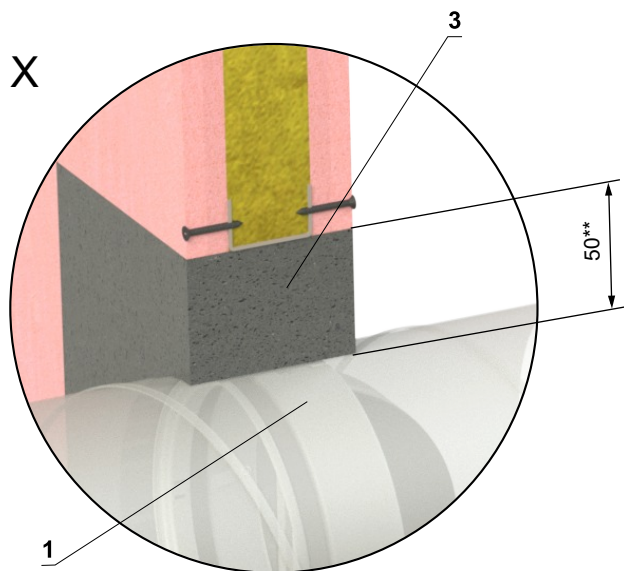

\* CFDM 60 dampers can be installed at a minimum distance of 30 mm from adjacent structures.

\*\* For damper CFDM 60, the approved installation opening between the construction and the damper is between 30...120 mm.

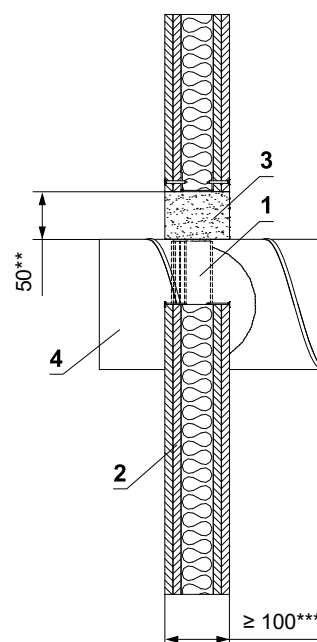
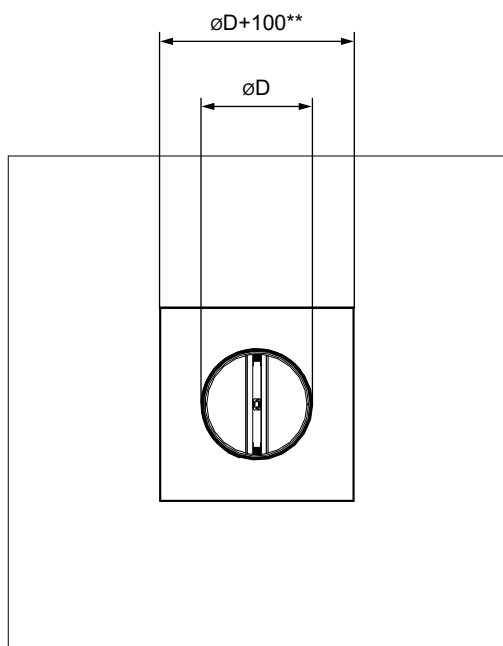

- 1 CFDM
- 2 Gypsum wall construction
- 3 Mortar or gypsum
- 4 Duct

\*\*\* ≥ 100 mm for dampers CFDM 60/90  
 ≥ 125 mm for damper CFDM 120

In gypsum wall construction - Ablative Coated Batt

EI 90 (ve) S [V/H]

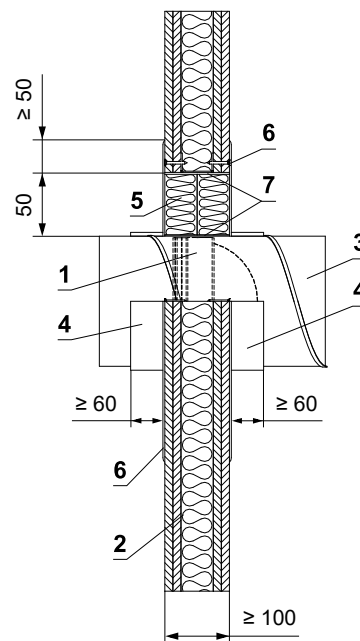
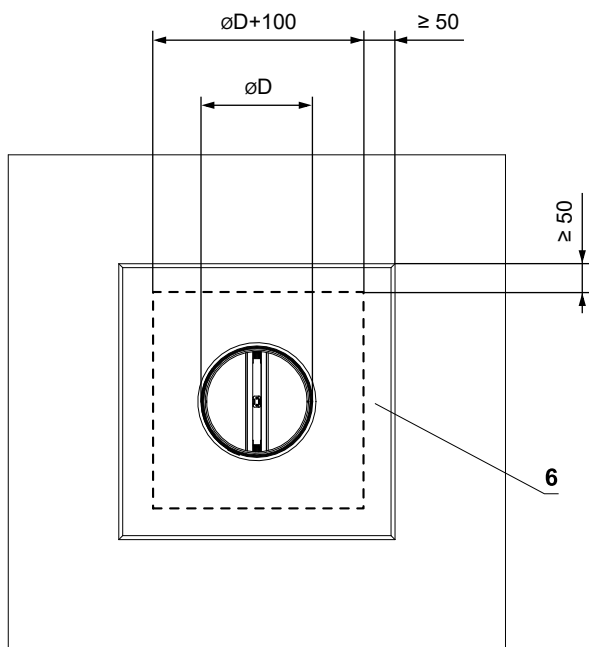
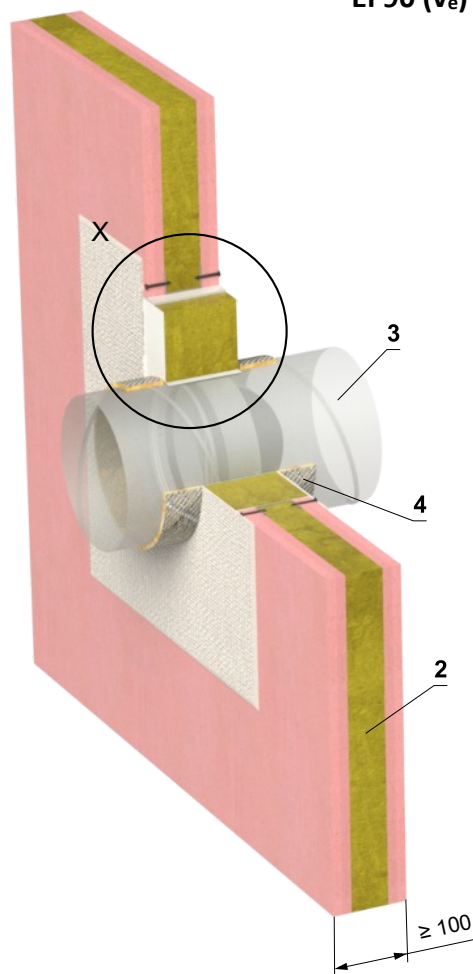
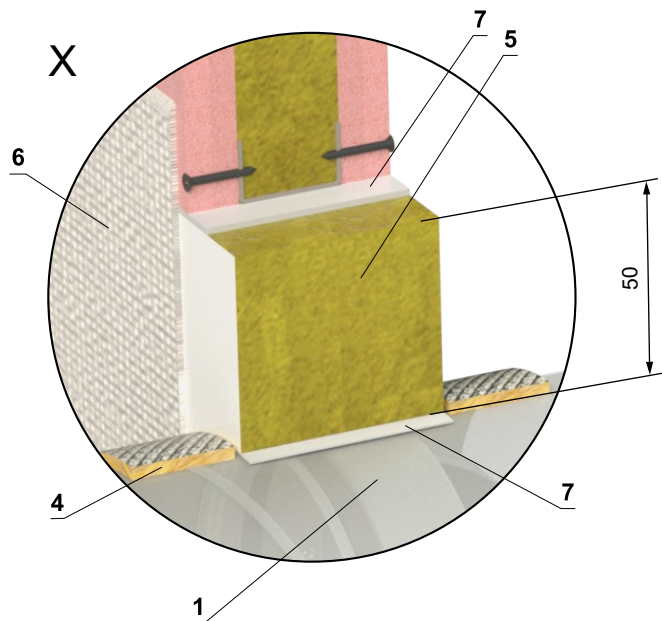

- 1 CFDM
- 2 Gypsum wall construction
- 3 Duct
- 4 Self-adhesive insulating tape, 6 mm thick, min. 60 mm wide (Kerafix 2000) - stick to the duct on both sides of the fire separation construction Ablative Coated Batt System HILTI\*
- 5 Mineral wool board - min. density  $140 \text{ kg/m}^3$  (HILTI CFS-CT B 1S 140/50...)
- 6 Fire stop coating - th. 1 mm (HILTI CFS-CT...) - coating is overcoated on the support construction and on the duct.
- 7 Fire-resistant mastic - (HILTI CFS-S ACR...) fill the gap from both sides of the fire separation construction and around the perimeter of penetration and the duct.

\* HILTI system can be replaced by a similar system with the same or higher thickness, density, fire reaction class, tested according to EN 1366-3.

In gypsum wall construction - up to 4 dampers in one installation opening - mortar or gypsum

\*EI 60 (v<sub>e</sub>) S [V/H]

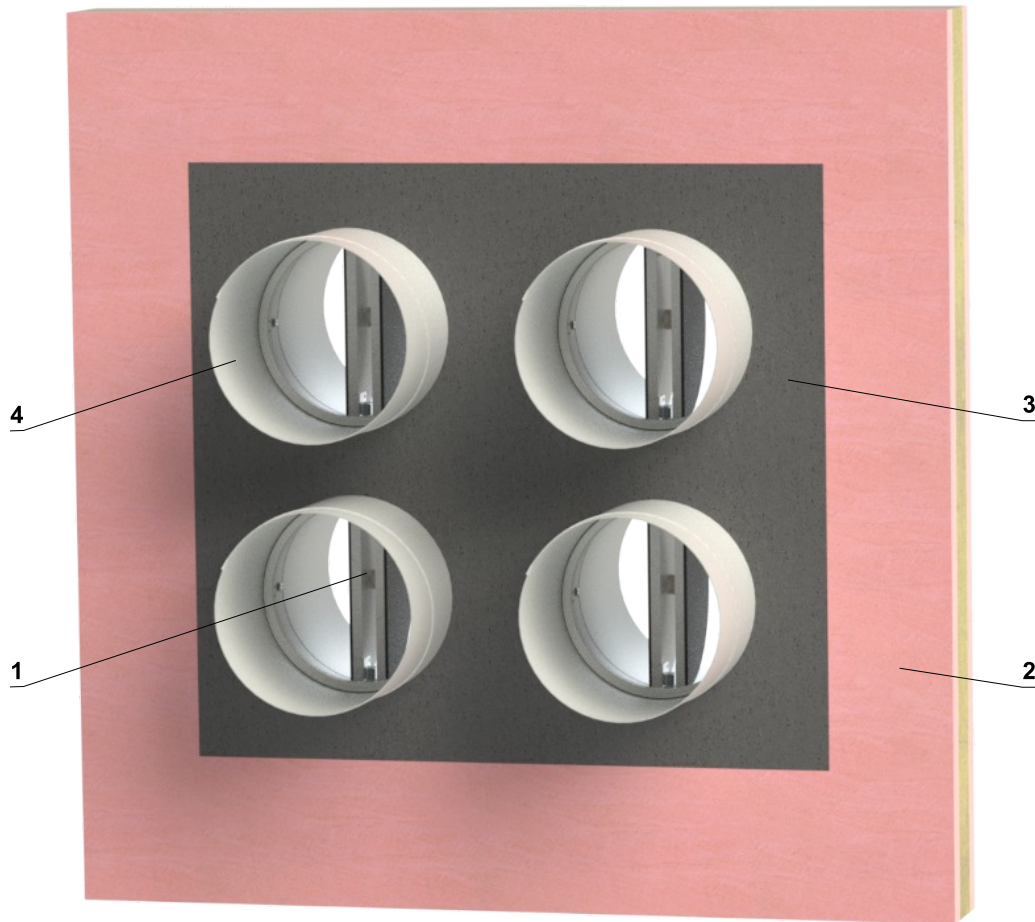

\* CFDM 60 dampers can be installed at a minimum distance of 30 mm from adjacent structures.

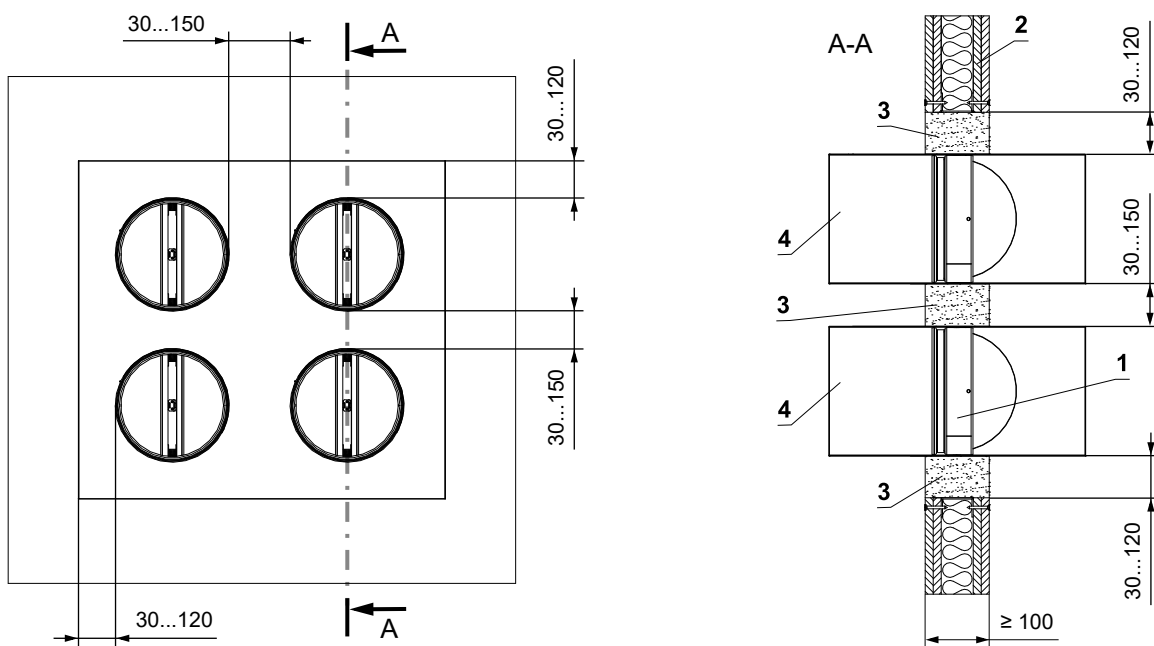

- 1 CFDM
- 2 Gypsum wall construction
- 3 Mortar or gypsum
- 4 Duct

**Installation in solid ceiling construction**

**In solid ceiling construction - mortar or gypsum**

EI 60 (h<sub>o</sub>) S [H]

EI 90 (h<sub>o</sub>) S [H]

- Depending on the required fire resistance, it is necessary to use a damper type with the appropriate fire resistance.

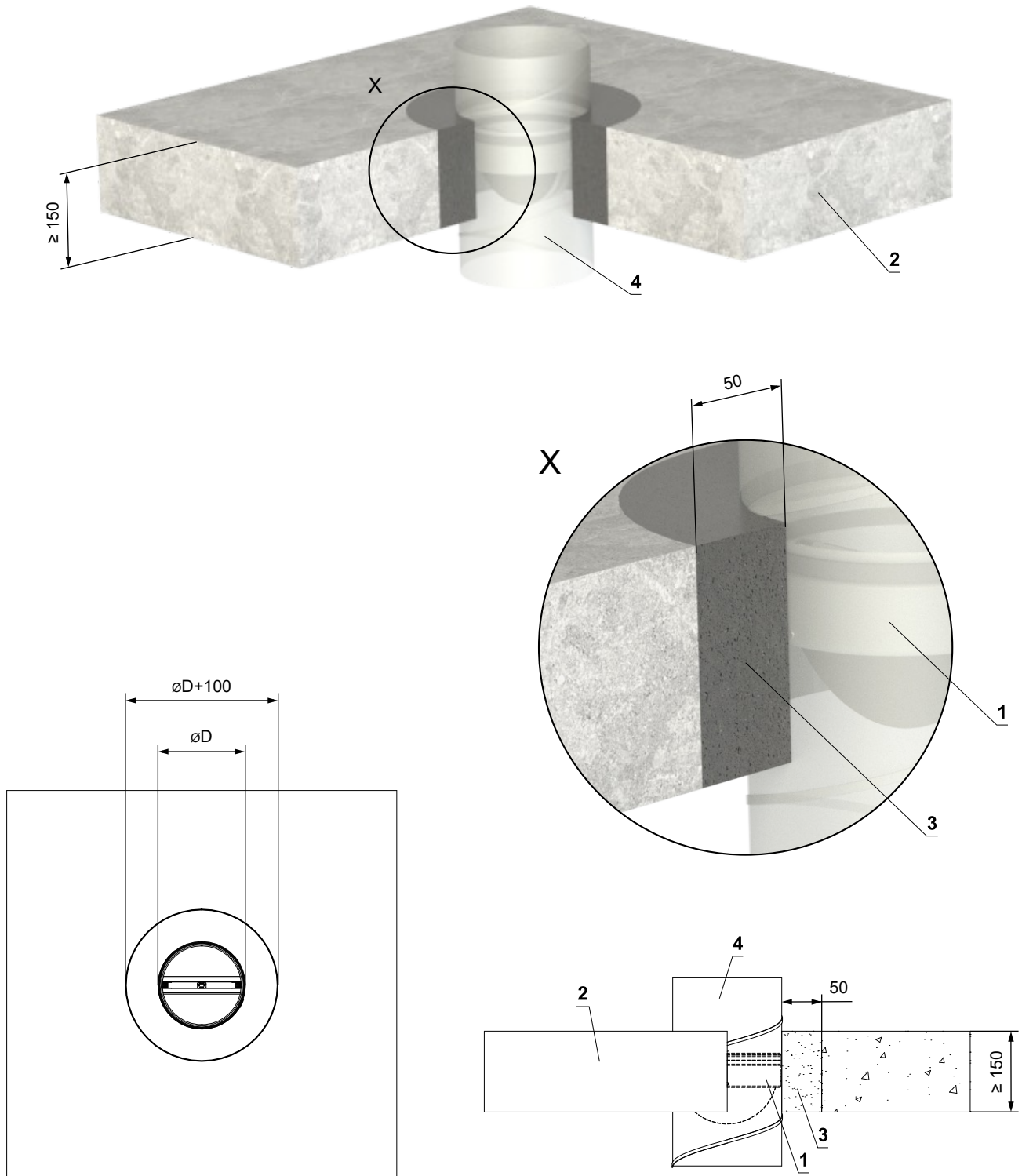

- 1 CFDM
- 2 Solid ceiling construction
- 3 Mortar or gypsum
- 4 Duct

Installation procedure of the CFDM / CFDM-V damper in the fire separation construction

CFDM damper installation

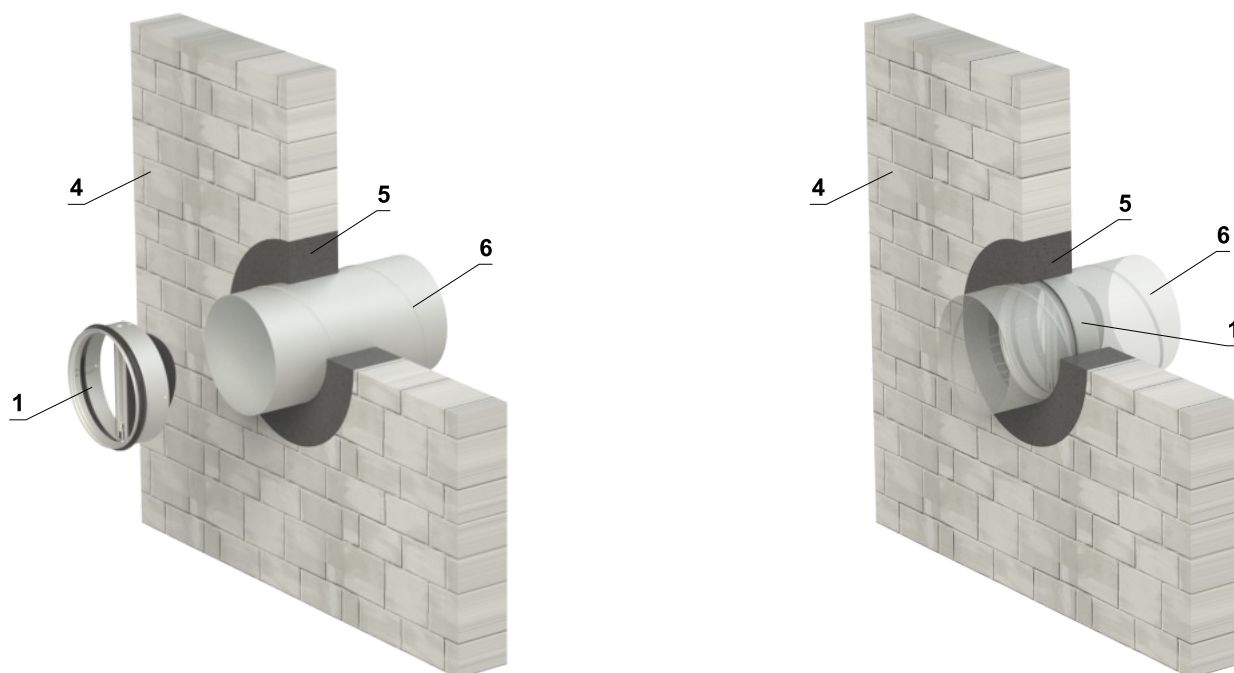

Installation procedure of the CFDM damper

- 1) Place the duct in the installation opening and fill the penetration with the required material.
- 2) Insert the damper into the duct so that the damper blade (in the closed position) is located in the middle of the fire separation construction.

CFDM-V damper installation

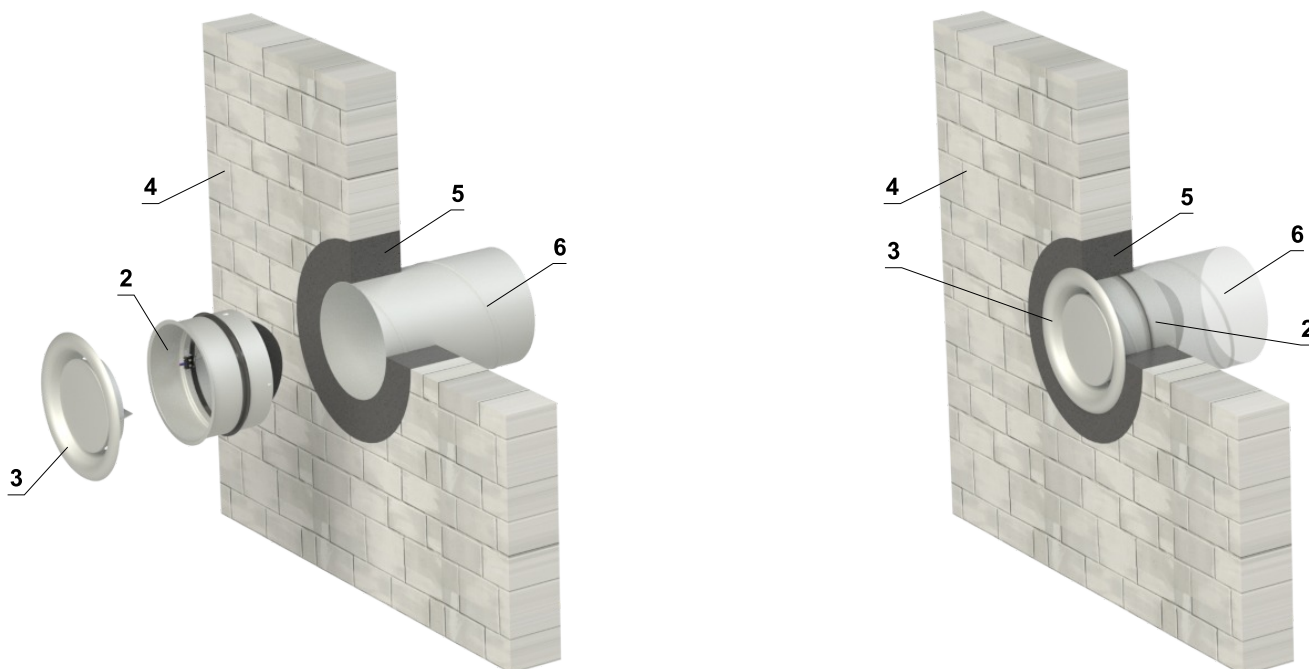

Installation procedure of the CFDM-V damper

- 1) Place the duct with the edge of the fire construction in the installation hole and fill the penetration with the required material.
- 2) Insert the damper into the duct.
- 3) Insert dish valve into the damper.

- |                             |                                |
|-----------------------------|--------------------------------|
| 1 CFDM                      | 4 Fire separation construction |
| 2 CFDM-V                    | 5 Penetration                  |
| 3 Dish valve - TVOM or TVPM | 6 Duct                         |



# V. TECHNICAL DATA

## Pressure loss

### Pressure loss calculation

$$\Delta p = \xi \cdot \rho \cdot \frac{w^2}{2}$$

- $\Delta p$  [Pa] pressure loss
- $w$  [m/s] air flow speed in nominal damper section
- $\rho$  [kg/m<sup>3</sup>] air density
- $\xi$  [-] coefficient of local pressure loss for the nominal damper section

### Determination of pressure loss by using diagram $\rho = 1,2 \text{ kg/m}^3$

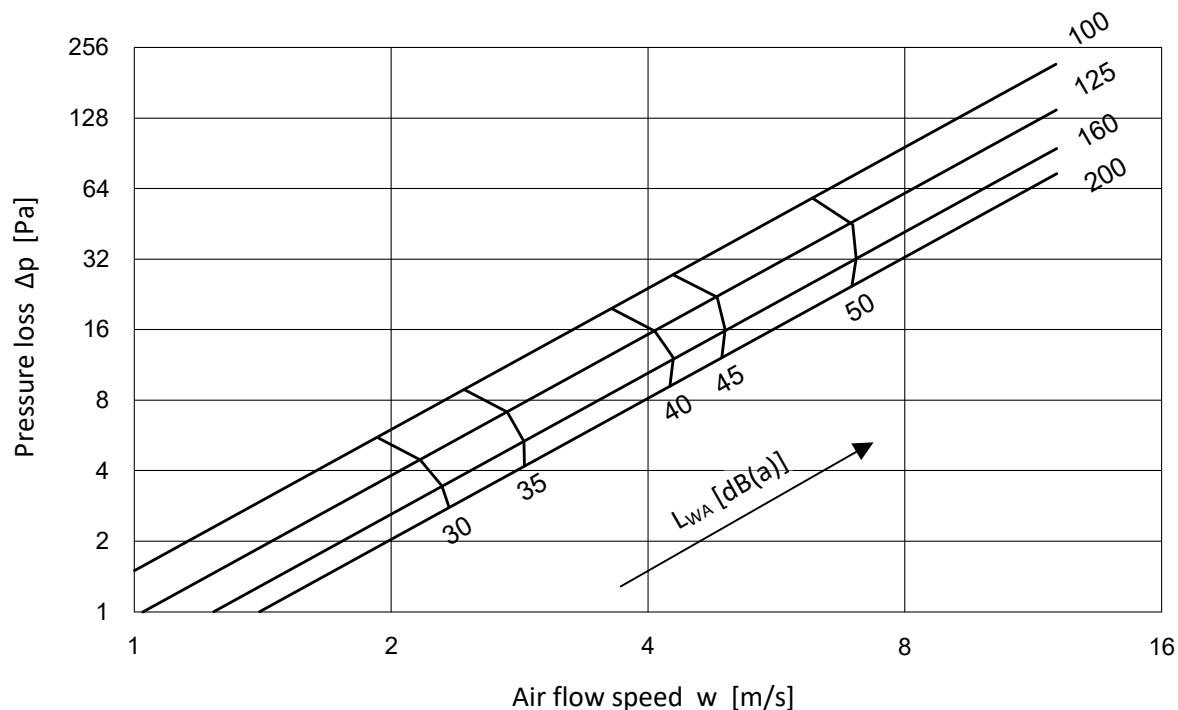

### Coefficient of local pressure loss

D	100	125	160	200
$\xi$	2,502	1,591	1,086	0,848

Technical data (pressure losses and noise data) of the CFDM damper in combination with TVPM or TVOM dish valve are given in TPM 028/03

## VI. MATERIAL, FINISHING

- Damper casings are made from galvanized sheet metal without further surface treatment.
- Damper blades are made from fire resistant asbestos free boards made of mineral fibres.
- Damper controls are made of stainless steel with no other surface finish.
- Springs are made of stainless steel.
- Thermal fuses are made of sheet brass, thickness 0,5 mm.
- Fasteners and springs are galvanized.
- Damper CFDM and CFDM-V are not manufactured in stainless steel.

## VII. TRANSPORTATION, STORAGE AND WARRANTY

### Logistic terms

- Dampers are delivered on pallets. As standard, the dampers are wrapped in plastic foil for protection during transport and must not be used for long-term storage. Temperature changes during transport can cause condensation of water inside the packaging and thereby cause corrosion of materials used in the dampers (e.g. white corrosion on zinc-coated items or mould on calcium silicate). Therefore, it is necessary to remove the transport packaging immediately after unloading to allow air to circulate around the product.
- Another required packaging system should be approved and agreed by manufacturer. Packaging material is not returnable in case that another packaging system (material) is required and used and it is not included into final price of damper.
- Dampers are transported by box freight vehicles without direct weather impact, there must not occur any shocks and ambient temperature must not exceed +50°C. Dampers must be protected against impact when transported and manipulated. During transportation, the damper blade must be in the "CLOSED" position.
- Dampers must be stored indoor in environment without any aggressive vapours, gases or dust. Indoor temperature must be in the range from -30°C to +50°C and maximum relative humidity 95%.

### Warranty

- The manufacturer provides a warranty of 24 months from the date of dispatch for the dampers.
- The warranty for fire dampers CFDM and CFDM-V, provided by the manufacturer, is completely void if actuating, closing and control devices are unprofessionally handled by untrained workers or if electric components, i.e. limit switches are dismantled.
- The warranty is void if dampers are used for other purposes, devices and working conditions than those allowed by these technical conditions or if the dampers are mechanically damaged during handling.
- If the dampers are damaged by transport, a record must be written down with the forwarder at reception for later complaint.

## VIII. ASSEMBLY, ATTENDANCE AND MAINTENANCE

- Assembly, maintenance and damper function check can be done only by qualified and trained person, i.e. "AUTHORIZED PERSON" according to the manufacturer documentation. All works done on the fire dampers must be done according international and local norms and laws.
- All effective safety standards and directives must be observed during damper assembly.
- To ensure reliable damper function it is necessary to avoid blocking the actuating mechanism and contact surfaces with collected dust, fibre and sticky materials and solvents.

### Limit switches

- If the damper is equipped with limit switches and these switches are not used during operation (e.g. because of a project change), they can be left on the damper and not connected (they need not be dismantled).
- On the other hand, if the limit switch is to be added to the damper design, the change can be implemented by change kit.
- These facts must be recorded in the respective operation documentation of the damper (record books of the damper, fire logs, etc.) and subsequently, adequate function checks must be carried out.

### Commissioning and revisions

- Before putting the damper into operation, serviceability checks and functional tests must be carried out including testing of functionality of all electrical elements. After putting into operation these serviceability checks must be carried at least twice a year. If no defect is found during two subsequent serviceability checks, these checks can be carried out once a year.
- In case that dampers are found unable to serve for their function for any cause, it must be clearly marked. The operator is obliged to ensure that the damper is put into condition in which it is ready for function and meanwhile he is obliged to provide the fire protection by another appropriate way.
- Results of regular checks, imperfections found and all-important facts connected with the damper function must be recorded in the "FIRE BOOK" and immediately reported to the operator.
- Visual inspection of proper damper installation, inner area of a damper, damper blade, contact surfaces and silicon seal.

# IX. ORDERING INFORMATIONS

## Ordering key

### Fire damper CFDM

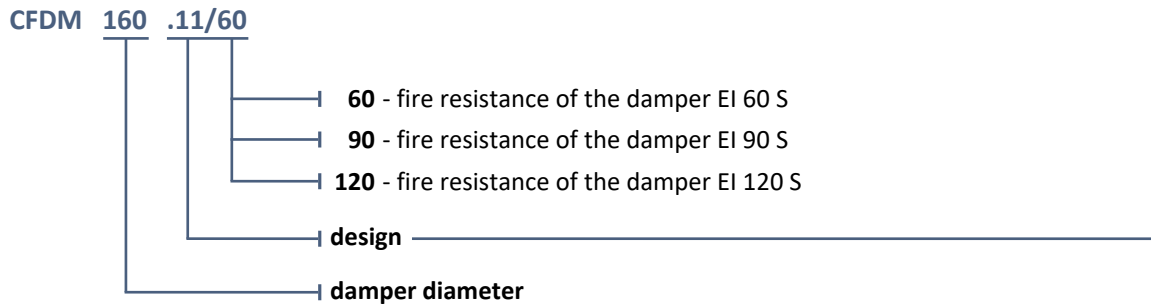

**EXAMPLE:**

**CFDM 160 .11/60** - 160-damper diameter, .11-damper design, /60-fire resistance of the damper EI 60 S

### Fire damper CFDM-V

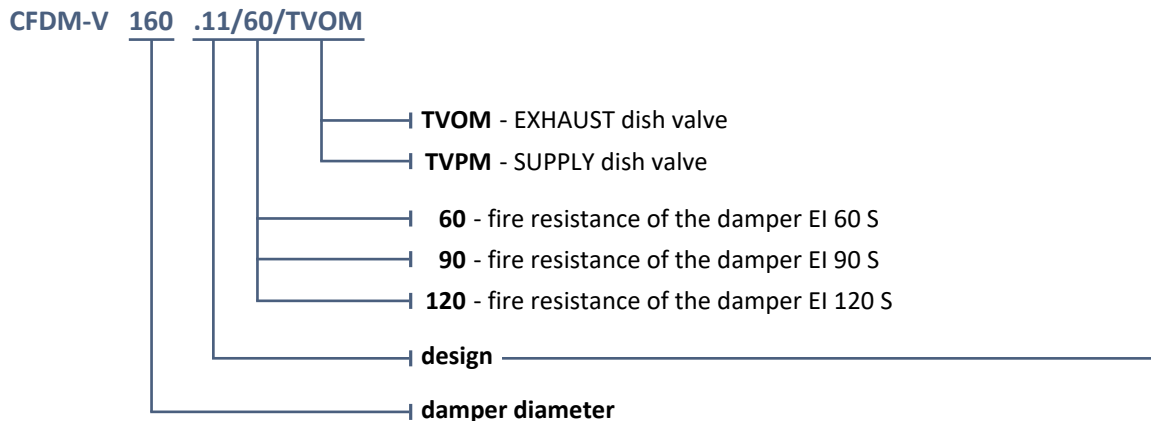

**EXAMPLE:**

**CFDM-V 160 .11/60/TVOM** - 160-damper diameter, .11-damper design, /60-fire resistance of the damper EI 60 S, /TVOM-EXHAUST dish valve

Damper design	Additional digit
Thermal with inner mechanical control	.01
Thermal with inner mechanical control and 1 limit switch („CLOSED“)	.11
Thermal with inner mechanical control and 2 limit switches („CLOSED“)	.15

## Data label

- Data label is placed on the damper casing (example)

## Fire damper CFDM

<b>MANDÍK</b>	MANDÍK, a.s. 267 24 Hostomice	Dobříšská 550 Czech Republic	<b>CFDM</b>	Požární klapka / Fire damper / Brandschutzklappe / Clapet coupe-feu
Klasifikace / Classification / Feuerwiderstand / Classification			EI90 (ve, ho-i↔o)S	
Certifikace / Certificate / Zulassungs-Nr. / Certifikat			1391-CPR-XXXX/XXXX	
Rozměr / Size / Grösse / Taille			200	EN 15650:2010
Výr. číslo / Serial number / Fert. Nr. / Numéro de serie			SAMPLE	TPM 118/16
Provedení / Design / Ausführung / Conception			.01	<b>EIS 90</b>  1391
Hmotnost / Weight / Gewicht / Poids			0,5	

## Fire damper CFDM-V

<b>MANDÍK</b>	MANDÍK, a.s. 267 24 Hostomice	Dobříšská 550 Czech Republic	<b>CFDM-V</b>	Požární klapka / Fire damper / Brandschutzklappe / Clapet coupe-feu
Klasifikace / Classification / Feuerwiderstand / Classification			EI90 (ve, ho-i↔o)S	
Certifikace / Certificate / Zulassungs-Nr. / Certifikat			1391-CPR-XXXX/XXXX	
Rozměr / Size / Grösse / Taille			200	EN 15650:2010
Výr. číslo / Serial number / Fert. Nr. / Numéro de serie			SAMPLE	TPM 118/16
Provedení / Design / Ausführung / Conception			.01/TVOM	<b>EIS 90</b>  1391
Hmotnost / Weight / Gewicht / Poids			1,34	

The producer reserves the right for innovations of the product.  
For actual product information see [www.mandik.com](http://www.mandik.com)

**MANDÍK**<sup>®</sup>  
[www.mandik.com](http://www.mandik.com)