

MSD (MSD-W)

Multi compartment smoke control damper

Technical Documentation

Installation, Commissioning, Operation, Maintenance and Service Manual

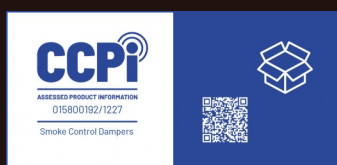
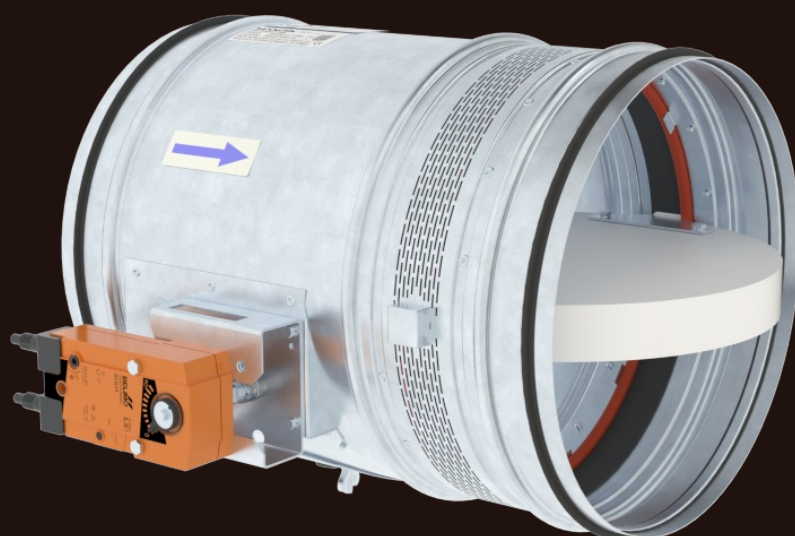

These technical specifications state a row of manufactured sizes, main dimensions, design and range of use of multi compartment smoke control dampers MSD. It is valid for production, design, ordering, delivery, storage, assembly, operation, maintenance and serviceability checks.

CONTENT

I. GENERAL.....	3
Description.....	3
II. DESIGN.....	5
Design with actuating mechanism.....	5
Design with electric actuating mechanism with emergency function and electromagnet.....	10
III. DIMENSIONS.....	14
Technical parameters.....	18
For square dampers.....	18
For round dampers.....	28
IV. INSTALLATION.....	29
Placement and installation.....	29
Statement of installations.....	32
In solid wall construction.....	33
In gypsum wall construction.....	38
In solid ceiling construction.....	43
Installation damper into/onto smoke extraction ducts.....	48
V. SUSPENSION SYSTEMS.....	50
Example of duct connection.....	52
VI. TECHNICAL DATA.....	53
Pressure loss.....	53
Noise data.....	55
VII. MATERIAL, FINISHING.....	56
VIII. TRANSPORTATION, STORAGE AND WARRANTY.....	57
Logistic terms.....	57
Warranty.....	57
IX. ASSEMBLY, ATTENDANCE AND MAINTENANCE.....	58
Electrical connection of the actuator in protection box.....	60
Entry into service and revisions.....	61
X. ORDERING INFORMATIONS.....	62
Ordering key MSD.....	62
Square damper MSD.....	62
Round damper MSD.....	62
Ordering key MSD-W.....	63
Square damper MSD-W.....	63
Round damper MSD-W.....	63
Data label.....	64

I. GENERAL

Description

Smoke control dampers – MULTI are closures installed in ductwork of smoke extraction systems. In the event of fire, the Smoke and Heat Exhaust Ventilation Systems system opens the dampers in the affected section, thereby allowing the exhaust fans to remove combustion products and heat from the endangered areas.

The damper blade is controlled by electrical actuating mechanism.

Dampers are fire resistant and are intended for systems with automatic activation.

Dampers can be installed in the structure of the fire compartment.

Dampers are designed for use in fire compartments that can be connected to smoke exhaust ducts (tested according to EN 1366-10), or they can be installed in or on the structure of the fire compartment.

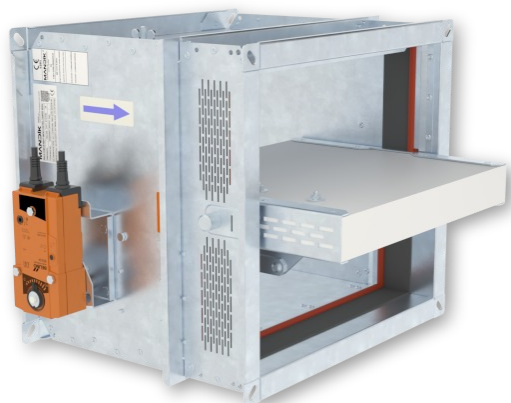

MSD - square

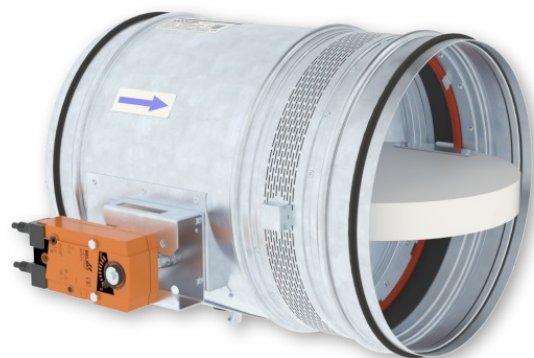

MSD - round

Basic types of square dampers

- MSD - Cycling test with load (possible design .44, .54, .65)
- MSD-W - Cycling test without load (possible design .44, .54, .4M0, .4M1, .5M0, .5M1)

Basic types of round dampers

- MSD - Cycling test with load (possible design .44, .54)
- MSD-W - Cycling test without load (possible design .4M0, .4M1, .5M0, .5M1)

MSD dampers can be open against flow and pressure.

MSD-W dampers has to be open with the help of flow or without flow present.

Damper characteristics

- CE certified acc. to EN 12101-8
- Tested in accordance with EN 1366-10
- Classified acc. to EN 13501-4
- External Casing leakage class ATC 3 (old marking "C"), Internal leakage min. class 2 acc. to EN 1751
- Leakage across the blade: round dampers - min. class 2, diameters from 560 mm to 630 mm
min. class 3 according to EN 1751
square dampers - min. class 2, for max. size 1500 × 800 mm
min. class 3 according to EN 1751
- Cycling: MSD square dampers C_{mod} according to EN 12101-8
MSD, MSD-W round dampers C_{10000} according to EN 12101-8
MSD-W square dampers C_{10000} according to EN 12101-8 (tested without load according to EN 1366-10)
- EC Certificate of Conformity No. 1391-CPR-XXXX/XXXX for MSD
- EC Certificate of Conformity No. 1391-CPR-XXXX/XXXX for MSD-W
- Declaration of Performance No. PM/MSD/01/XX/X, PM/MSD-W/01/XX/X
- Hygienic assessment – Report No. 1.6/pos/19/19c

Classification of square dampers		
Supporting construction	Installation type	Classification
Horizontal or vertical smoke extraction ducts tested according to EN 1366-8 or EN 1366-9 <ul style="list-style-type: none"> • Into or onto the duct 	Damper installed Into or onto a duct	EI 120 (h _{od}) S1500[H]C _{mod} HOT400/30AAmulti EI 120 (v _{ed}) S1500[H]C _{mod} HOT400/30AAmulti
Standard low- and high-density rigid wall construction according to EN 1363-1 <ul style="list-style-type: none"> • damper in the wall • 100 mm min. wall thickness 	Mortar or gypsum	EI 120 (v _{ew}) S1500[H]C _{mod} HOT400/30AAmulti * EI 120 (v _{ew}) S1500[H]C ₁₀₀₀₀ AAmulti
	Ablative Coated Batt	
Standard flexible wall construction min. EI 90 according to EN 1363-1 <ul style="list-style-type: none"> • damper in the wall • 100 mm min. wall thickness 	Mortar or gypsum	EI 120 (h _{ow}) S1500[H]C _{mod} HOT400/30AAmulti * EI 120 (h _{ow}) S1500[H]C ₁₀₀₀₀ AAmulti
	Ablative Coated Batt	
Standard low- and high-density rigid floor construction according to EN 1366-2 <ul style="list-style-type: none"> • damper in the ceiling • 150 mm min. ceiling thickness 	Mortar or gypsum	EI 120 (h _{ow}) S1500[H]C _{mod} HOT400/30AAmulti * EI 120 (h _{ow}) S1500[H]C ₁₀₀₀₀ AAmulti
	Ablative Coated Batt	

* Applies to MSD-W damper

Classification of round dampers		
Supporting construction	Installation type	Classification
Standard low- and high-density rigid wall construction according to EN 1363-1 <ul style="list-style-type: none"> • damper in the wall • 125 mm min. wall thickness 	Mortar or gypsum	EI 120 (v _{ew}) S1500[H]C ₁₀₀₀₀ AAmulti
Standard flexible wall construction min. EI 90 according to EN 1363-1 <ul style="list-style-type: none"> • damper in the wall • 125 mm min. wall thickness 	Mortar or gypsum	EI 120 (v _{ew}) S1500[H]C ₁₀₀₀₀ AAmulti
Standard low- and high-density rigid floor construction according to EN 1366-2 <ul style="list-style-type: none"> • damper in the ceiling • 150 mm min. ceiling thickness 	Mortar or gypsum	EI 120 (h _{ow}) S1500[H]C ₁₀₀₀₀ AAmulti

Working conditions

- Exact damper function is provided under the following conditions
 - maximum air velocity 15 m/s
 - underpressure max. -1500 Pa or overpressure max. 500 Pa
- Dampers can be installed with a horizontal blade axis.
- Dampers are designed for macroclimatic areas with mild climate according to EN IEC 60 721-3-3 ed.2., class 3K22. (Environment 3K22 is typically protected place with regulated temperature)
- Temperature in the place of installation is permitted to range from -30 °C to +50 °C.

II. DESIGN

Design with actuating mechanism

Design .44 and .54

- Belimo actuators are used for dampers, series BEN, BEE, BE for 230V AC resp. 24 V AC/DC, Schischek InMax 50.75-S actuators (universal 24V or 230V supply) are used for large size of dampers.
- After connection to the power supply voltage, the actuator moves the damper blade to the "OPEN" position or "CLOSED" (according to the corresponding connection, see wiring diagram). If the power supply is interrupted, the actuator stops at the current position. The signalling of the "OPEN" and "CLOSED" damper blade positions is ensured by two built-in fixed "potential-free" end- limit switches.
- The actuator for operating the damper blade is mounted in an insulated cover/box. It is accessible after removing the cover lid. The electrical connection of the actuator is made with a non-flammable cable (or a cable located in the adjoining cable duct), which passes through an opening made in the wall of the insulated cover/box when installing the damper or when connecting the actuator power cable. Cable penetrations must meet a minimum fire resistance of 30 minutes.

Design .65 - only for square dampers MSD

- Belimo modulating actuators, BEN (BEE)-SR series for 24V AC/DC are specially designed for remote control of smoke control dampers. The position of the damper blade is adjustable by means of control voltage 0 (2)...10V DC.
- The signalling of the "OPEN" and "CLOSED" damper blade positions is ensured by two built-in fixed "potential-free" limit switches.
- The actuator for operating the damper blade is mounted in an insulated cover/box. It is accessible after removing the cover lid. The electrical connection of the actuator is made with non-flammable cables (or cables located in the adjoining cable duct), which pass through an opening made in the wall of the insulated cover when installing the damper or when connecting the power cables of the actuator. Cable penetrations must meet a minimum fire resistance of 30 minutes.

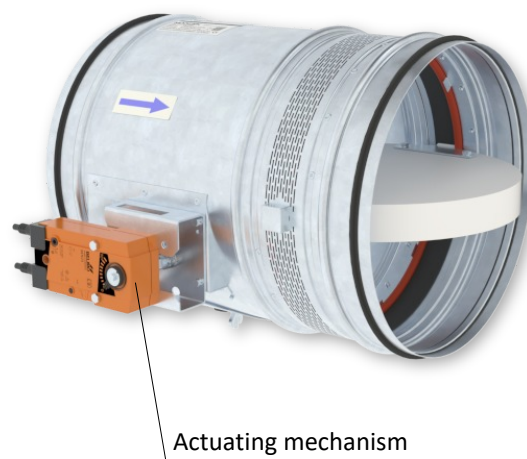
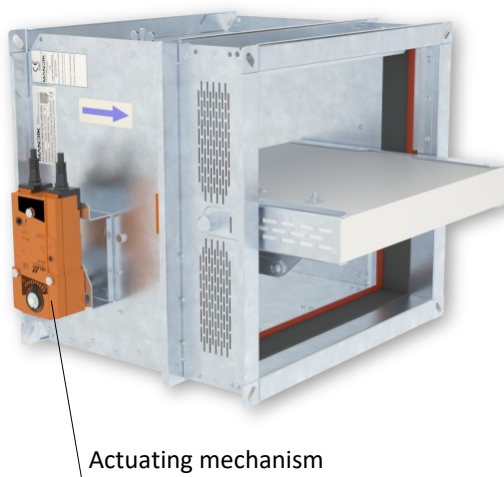

Design .44, .54 and .65

Actuator BELIMO BEN 24(-ST)

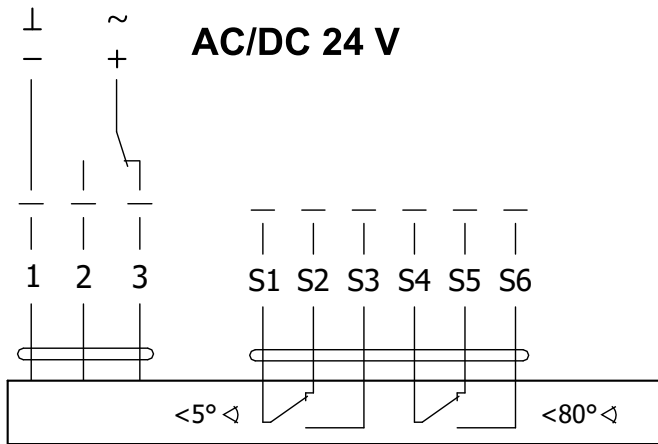

Actuator BELIMO BEN 24-SR

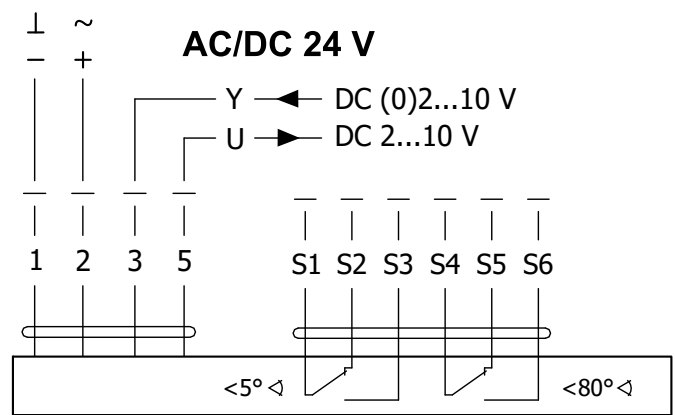

Actuator BELIMO BEN 230

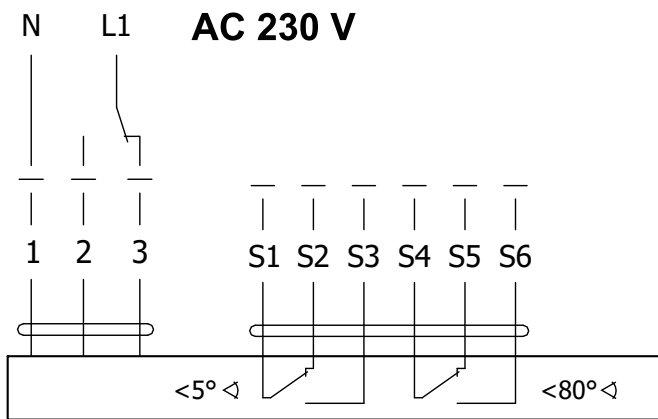

Actuator BELIMO BEN 24(-ST), BEN 24-SR, BEN 230

Actuator BELIMO - 15 Nm	BEN 24(-ST)	BEN 24-SR*	BEN 230
Power voltage	AC/DC 24 V 50/60Hz	AC/DC 24 V 50/60Hz	AC 230 V 50/60Hz
Power consumption - in operation - in the end position	3 W 0,1 W	3 W 0,3 W	4 W 0,4 W
Dimensioning	6 VA (Imax 8,2 A @ 5 ms)	6,5 VA (Imax 8.2 A @ 5 ms)	7 VA (Imax 4 A @ 5 ms)
Protection class	III	III	II
Degree of protection		IP 54	
Adjustment time for 95°		< 30 s	
Ambient temperature Storage temperature		-30°C ... +55°C -40°C ... +80°C	
Connection - drive - auxiliary switch	Cable 1 m, 3 x 0,75 mm ² Cable 1 m, 6 x 0,75 mm ² (BEN 24-ST) with plug connectors	Cable 1 m, 4 x 0,75 mm ² Cable 1 m, 6 x 0,75 mm ²	Cable 1 m, 3 x 0,75 mm ² Cable 1 m, 6 x 0,75 mm ²

* Only available for 24V and selected damper sizes

Actuator BELIMO BEE 24(-ST)

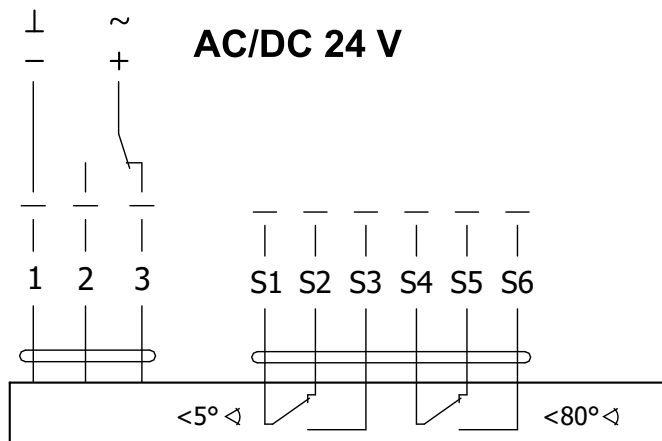

Actuator BELIMO BEE 24-SR

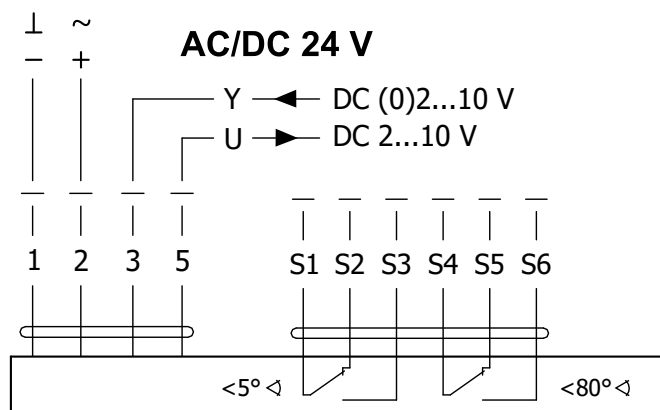

Actuator BELIMO BEE 230

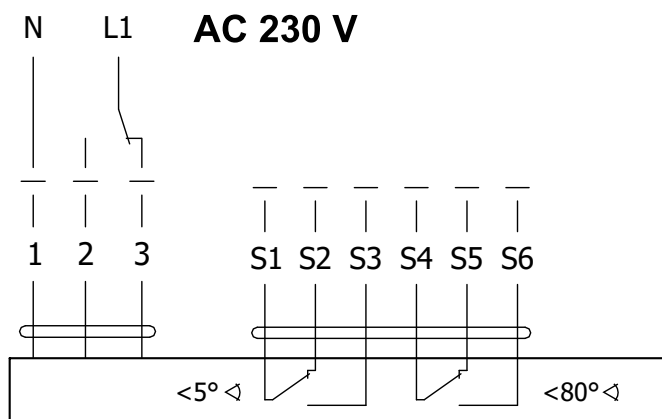

Actuator BELIMO BEE 24(-ST), BEE 24-SR, BEE 230

Actuator BELIMO - 25 Nm	BEE 24(-ST)	BEE 24-SR*	BEE 230
Power voltage	AC/DC 24 V 50/60Hz	AC/DC 24 V 50/60Hz	AC 230 V 50/60Hz
Power consumption - in operation - in the end position	2,5 W 0,1 W	3 W 0,3 W	3,5 W 0,4 W
Dimensioning	5 VA (Imax 8,2 A @ 5 ms)	5,5 VA (Imax 8.2 A @ 5 ms)	6 VA (Imax 4 A @ 5 ms)
Protection class	III	III	II
Degree of protection		IP 54	
Adjustment time for 95°		< 60 s	
Ambient temperature Storage temperature		-30°C ... +55°C -40°C ... +80°C	
Connection - drive - auxiliary switch	Cable 1 m, 3 x 0,75 mm ² Cable 1 m, 6 x 0,75 mm ² (BEE 24-ST) with plug connectors	Cable 1 m, 4 x 0,75 mm ² Cable 1 m, 6 x 0,75 mm ²	Cable 1 m, 3 x 0,75 mm ² Cable 1 m, 6 x 0,75 mm ²

* Only available for 24V and selected damper sizes

Actuator BELIMO BE 24-12(-ST)

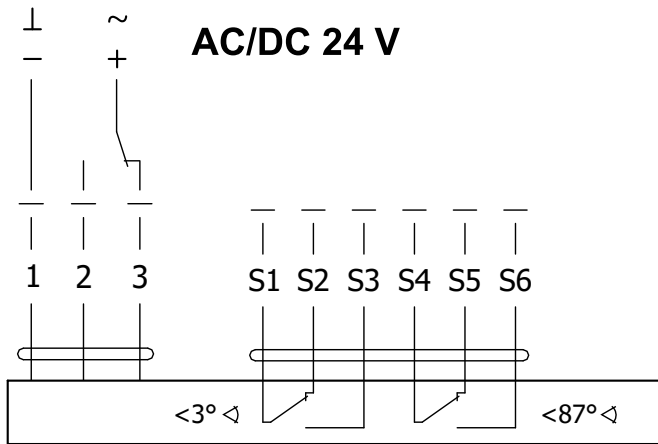

Actuator BELIMO BE 230-12

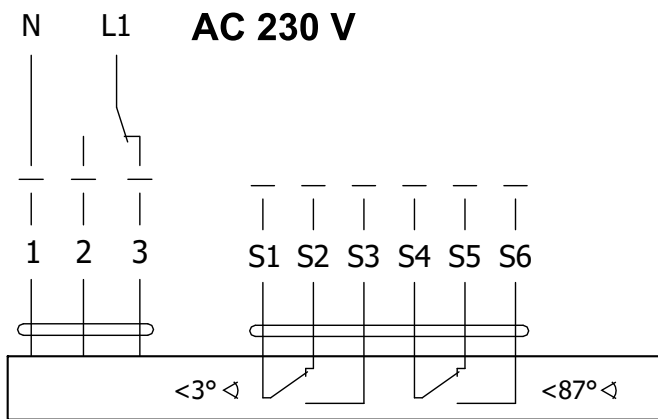

Actuator BELIMO BE 24-12(-ST), BE 230-12

Actuator BELIMO - 40 Nm	BE 24-12(-ST)	BE 230-12
Power voltage	AC/DC 24 V 50/60Hz	AC 230 V 50/60Hz
Power consumption - in operation - in the end position	12 W 0,5 W	8 W 0,5 W
Dimensioning	18 VA (I _{max} 8,2 A @ 5 ms)	15 VA (I _{max} 7.9 A @ 5 ms)
Protection class	III	II
Degree of protection	IP 54	
Adjustment time for 95°	< 60 s	
Ambient temperature	-30°C ... +55°C	
Storage temperature	-40°C ... +80°C	
Connection - drive - auxiliary switch	Cable 1 m, 3 x 0,75 mm ² Cable 1 m, 6 x 0,75 mm ² (BE 24-ST) with plug connectors	

Actuator SCHISCHEK InMax 50.75-S

24...230 VAC/DC

Integrated aux. switches max 24V/3A,
240V/0,25A switching at 5° and 85°.

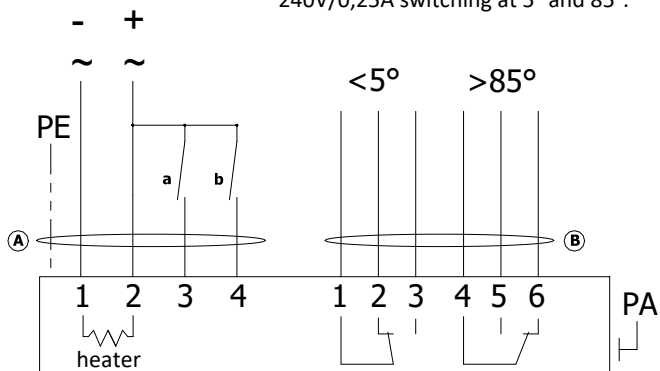

Actuator SCHISCHEK InMax 50.75-S

Actuator SCHISCHEK	InMax 50.75-S
Power voltage	24-240 VAC/DC 50/60Hz
Power consumption - in operation - heating	10 W 16 W (start at -20°C)
Protection class	I
Degree of protection	IP 66
Adjustment time for 95°	< 60 s
Ambient temperature	-40°C ... +50°C
Storage temperature	-40°C ... +70°C
Connection	cable 1 m, 0,5 mm ²

Design with electric actuating mechanism with emergency function and electromagnet

Design .4M0, .4M1, .5M0 and .5M1

- MSD-W is always equipped by electric actuating mechanism BFN 230-T, BFN 24-T, DAF2.20S or DAF1.20S (further only "actuating mechanism") and is complemented with initiation by means of an electromagnet (solenoid).
- After being connected to power supply AC/DC 24V or 230V, the actuating mechanism displaces the damper blade into operation position "CLOSED" and at the same time it pre-stretches its back spring. When the actuating mechanism is under voltage, the damper blade is in the position "CLOSED" and the back spring is pre-stretched. Time needed for full closing of the flap blade from the position "OPEN" to the position "CLOSED" is maximum 60 sec. This position is secured by initial lever. If the actuating power supply is cut off damper is still in the position "CLOSED". After activation of electromagnet is released initiation lever and the back spring displaces the damper blade into the breakdown position "OPEN".
- The time of displacing the blade from the position "OPEN" to the position "CLOSED" takes maximum 16 sec. In case that the power supply is restored again (the blade can be in any position), the actuating mechanism starts to re-displace the damper blade into the position "CLOSED".
- By voltage AC 230 V is damper equipped by electromagnet EM230. By voltage AC/DC 24 V is damper equipped by electromagnet EM230 with pre-pulse switch SIEM24. SEIM24 activates the electromagnet after capacitor charge witch is placed inside of SIEM24. It takes about 10 sec.
- Charging time depends on the current supply. For reliable operation is necessary connect to electromagnet or pre-pulse switch appropriate supply for 2 sec (230 V) or 20 to 30 sec (24 V).

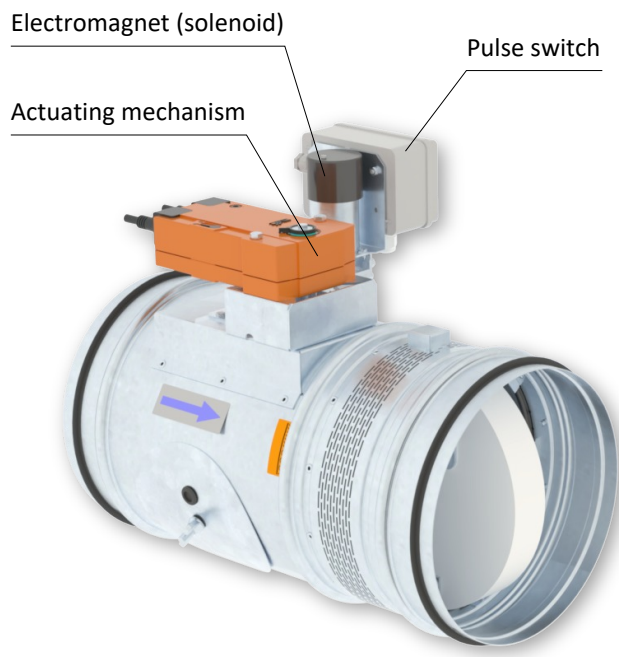
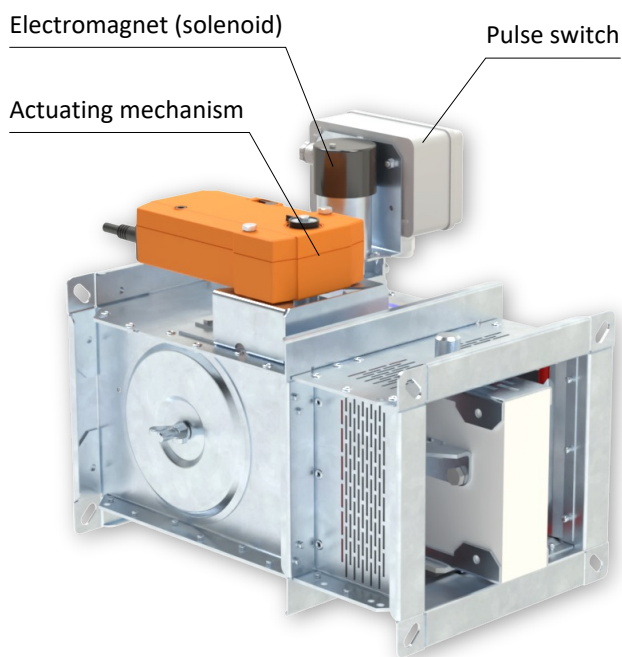

Design .4M0, .4M1, .5M0 and .5M1

Actuator BELIMO BFN 230

AC230 V

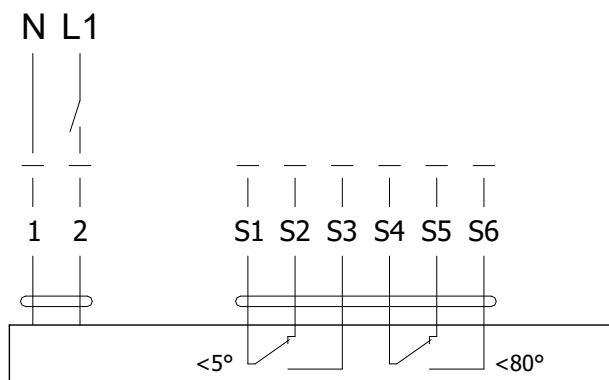

Actuator BELIMO BFN 24

AC/DC 24

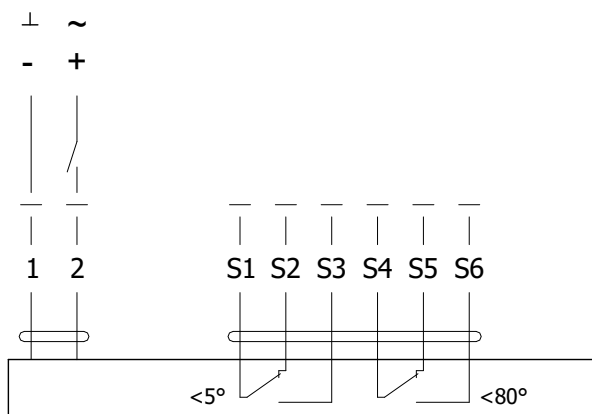

Actuator BELIMO BFN 230, BFN 24

Actuator BELIMO - 9 Nm/ 7 Nm Spring	BFN 230	BFN 24
Power voltage	AC 230 V 50/60Hz	AC/DC 24 V 50/60Hz
Power consumption - in operation	3,5 W	3,2 W
- in rest position	1,3 W	1,2 W
Dimensioning	6,5 VA (I _{max} 4 A @ 5 ms)	4,3 VA (I _{max} 2,9 A @ 5 ms)
Protection class	II	III
Degree of protection	IP 54	
Running time - motor	< 60 s	
- spring return	~ 20 s	
Ambient temperature	-30°C ... +55°C	
- normal duty	The safe position will be attained up to max. 75°C	
- safety duty	-40°C ... +55°C	
- non-operating temperature		
Connection - supply/control	cable 1 m, 2 x 0,75 mm ² (BFN 2xx-T-ST) with 3-pin plug-in connectors	
- auxiliary switch	cable 1 m, 6 x 0,75 mm ² (BFN 2xx-T-ST) with 6-pin plug-in connectors	
Response temperature thermal fuse	duct outside temperature +72°C duct inside temperature +72°C	

Actuator Joventa DAF1.20S and DAF2.20S

DAF1.20S

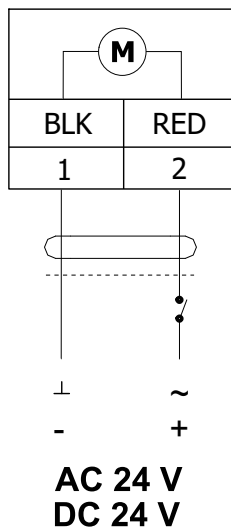

DAF2.20S

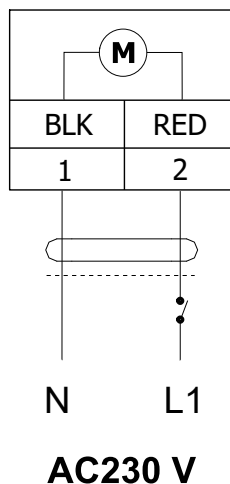

Limit switches

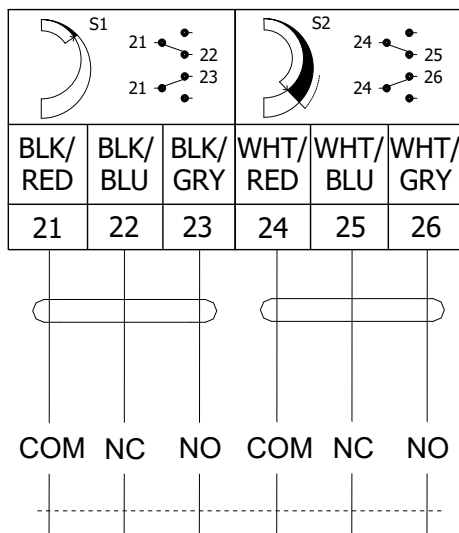

Actuator Joventa DAF1.20S and DAF2.20S

Actuator Joventa	DAF1.20S	DAF2.20S
Power voltage	AC/DC 24 V 50/60Hz	AC 230 V 50/60Hz
Power consumption - in operation	26 VA (AC); 15,6 W (DC)	0,15 A
- in rest position	9,3 VA (AC); 2,6 W (DC)	0,09 A
Dimensioning	14 VA	14 VA
Protection class	II	II
Degree of protection	IP 54	
Running time - motor	24...57 s	
- spring return	11...15 s	
Ambient temperature - normal duty	-40°C ... +55°C	
- non-operating temperature	-65°C ... +85°C	
Connection - motor	cable 1,2 m halogen-free; 2-wires	
- auxiliary switch	cable 1,2 m halogen-free; 6-wires	

Electromagnet EM230

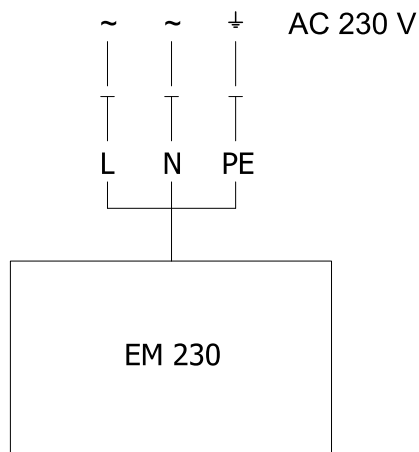

Electromagnet EM230

Nominal voltage	AC 230 V 50 Hz
Dimensioning	1,2 A
Degree of protection	IP 40
Ambient temperature range	-10°C ... +40°C
Connecting	cable 1m, 3x0,75mm ²

Electromagnet EM230 with impulse switch SIEM24

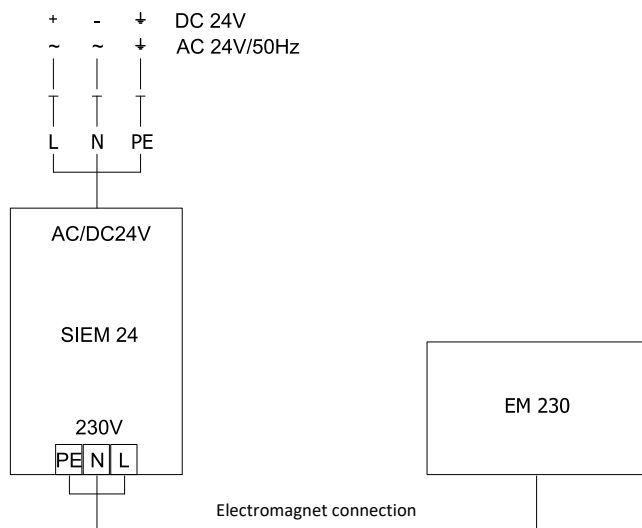

Electromagnet EM230 with impulse switch SIEM24

Nominal voltage	AC/DC 24 V 50 Hz
Dimensioning	1 A
Degree of protection	IP 40
Ambient temperature range	-10°C ... +40°C
Switching frequency	max. 1x per minute
Connecting	cable 1m, 3x0,75mm ²

III. DIMENSIONS

Square MSD (MSD-W) - design with spring return actuator

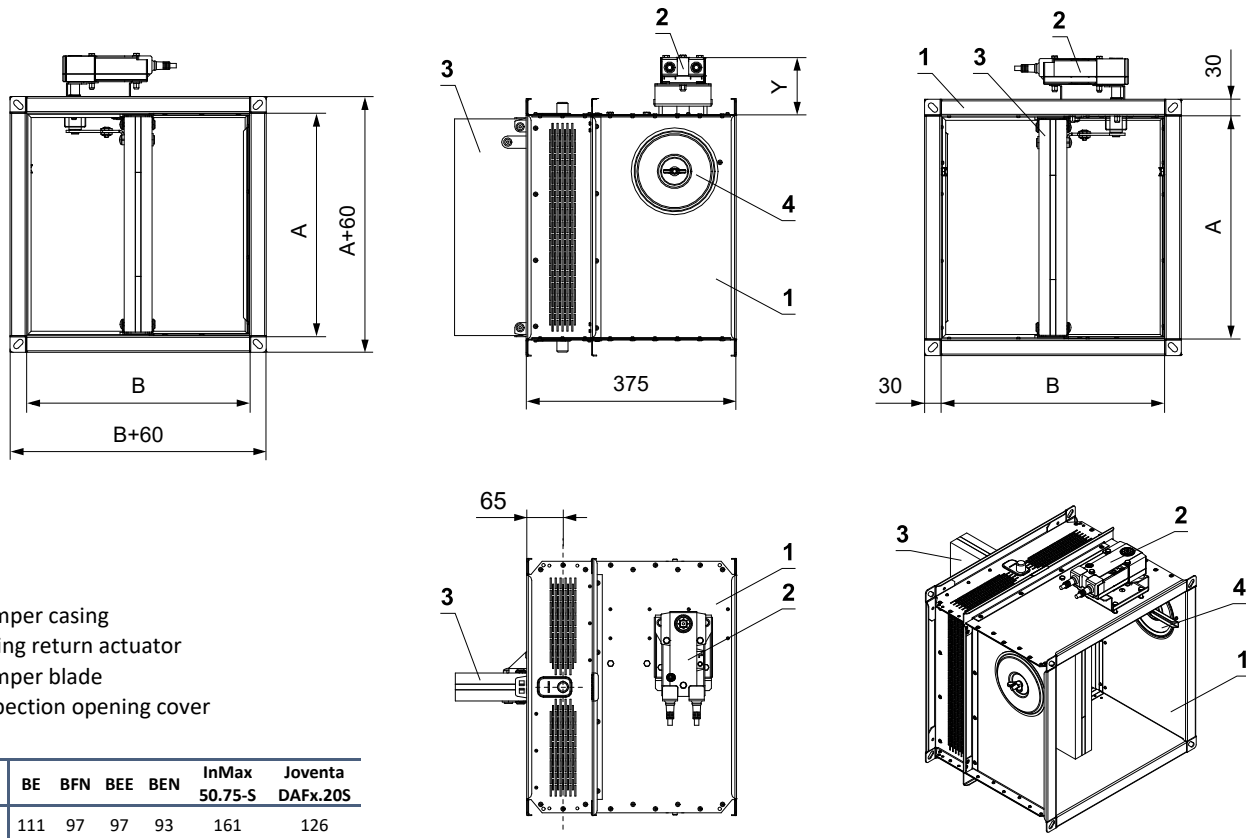

Square MSD - design with spring return actuator and insulation box

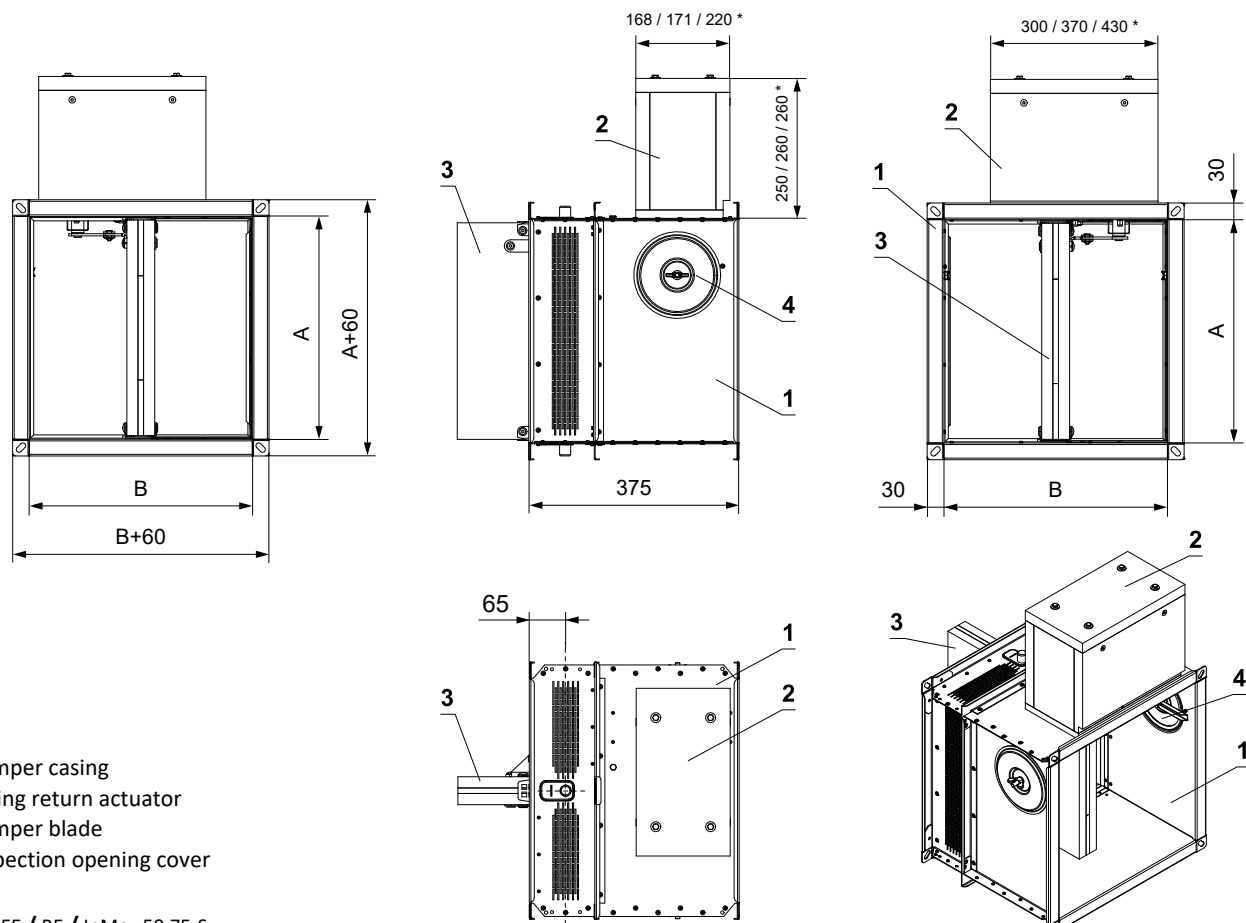

- 1 Damper casing
- 2 Spring return actuator
- 3 Damper blade
- 4 Inspection opening cover

* BEN, BEE / BE / InMax 50.75-S

Square MSD (MSD-W) - design with spring return actuator, insulation box and lining panels

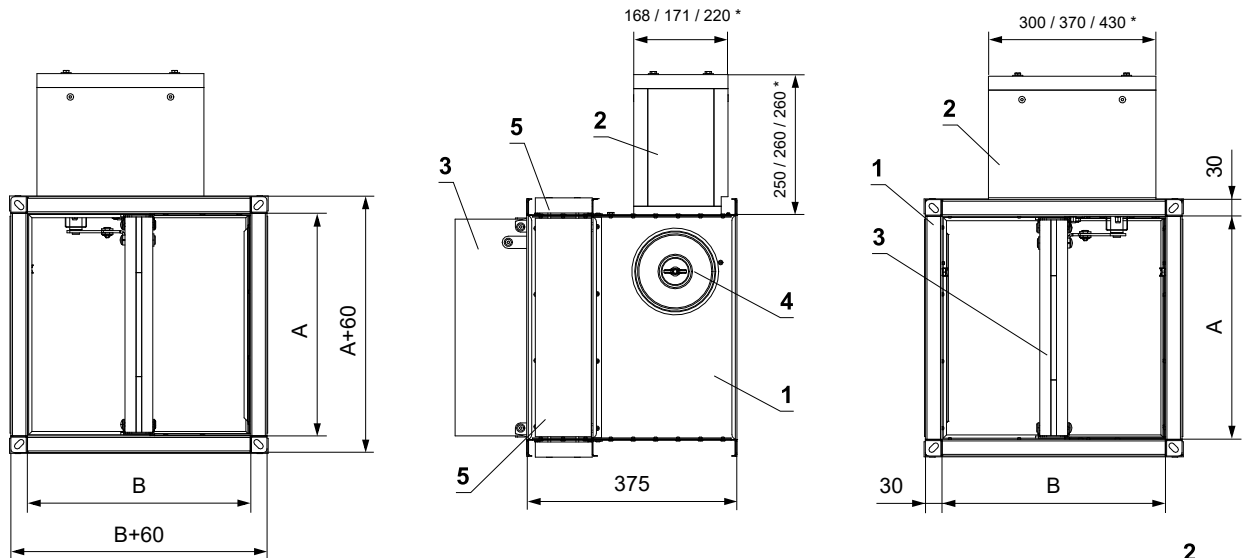

- 1 Damper casing
- 2 Spring return actuator
- 3 Damper blade
- 4 Inspection opening cover
- 5 Reinforcement of the damper with calcium silicate boards

* BEN, BEE / BE / InMax 50.75-S

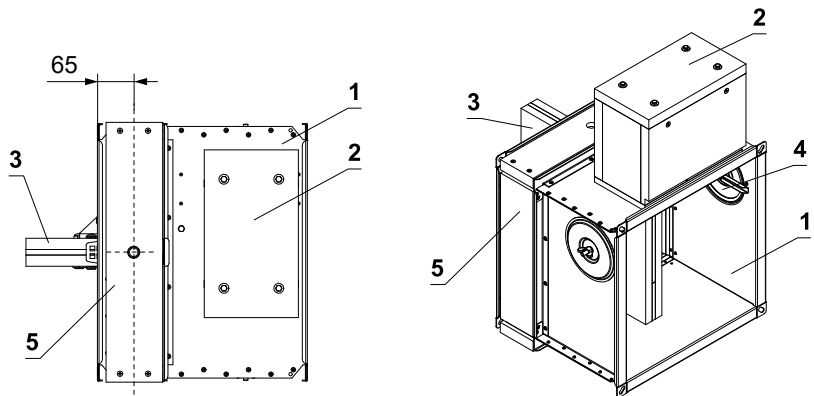

Square MSD-W - design with spring return actuator with emergency function and electromagnet

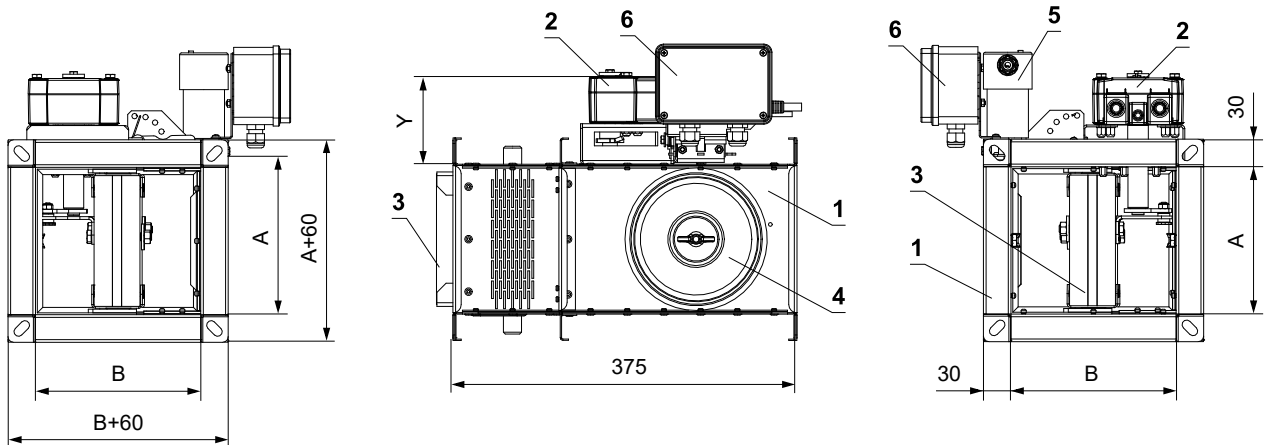

- 1 Damper casing
- 2 Spring return actuator
- 3 Damper blade
- 4 Inspection opening cover
- 5 Electromagnet
- 6 Impulse switch SIEM24

	BE	BFN	BEE	BEN	InMax 50.75-S	Joventa DAFx.20S
Y [mm]	111	97	97	93	161	126

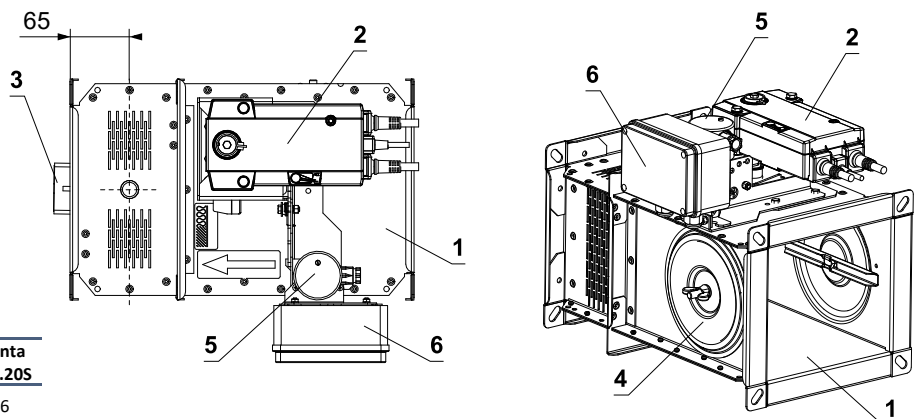

Round MSD (MSD-W) - design with spring return actuator

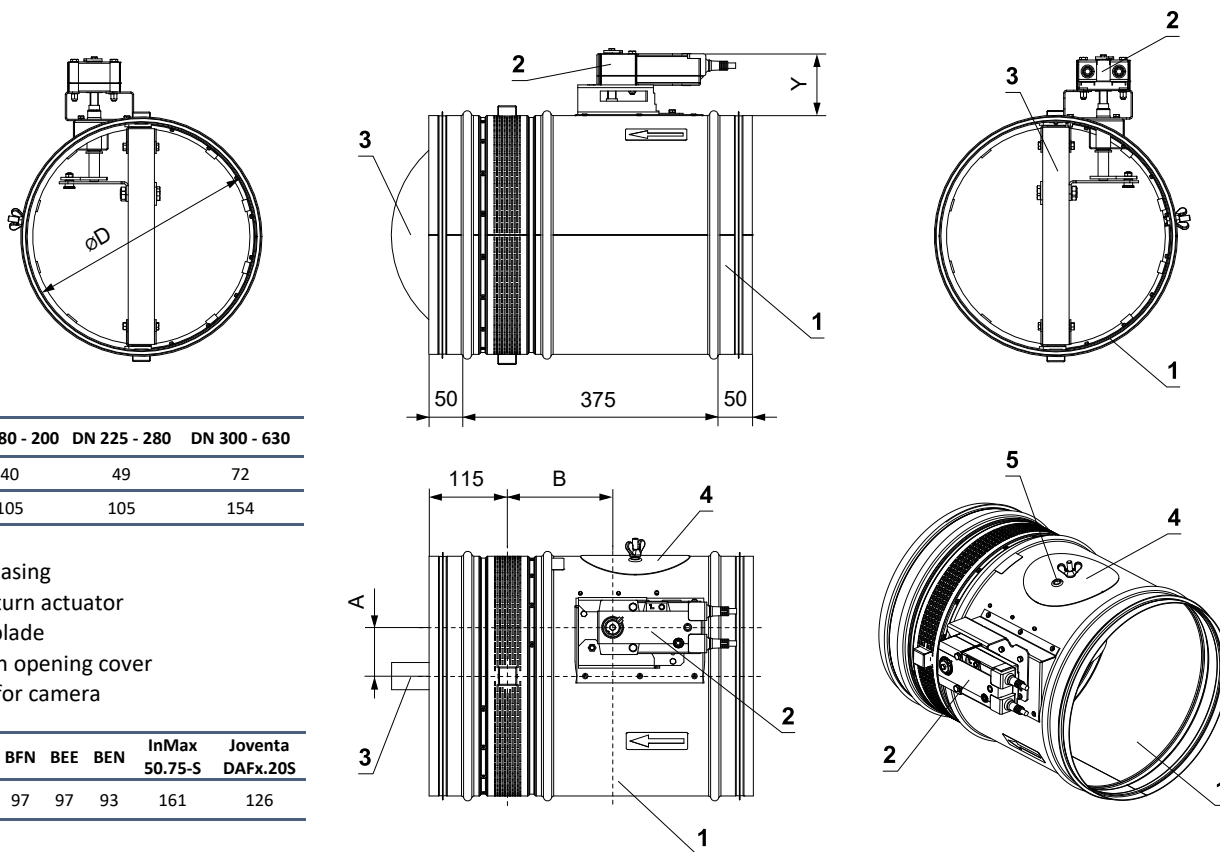

	DN 180 - 200	DN 225 - 280	DN 300 - 630
A [mm]	40	49	72
B [mm]	105	105	154

- 1 Damper casing
- 2 Spring return actuator
- 3 Damper blade
- 4 Inspection opening cover
- 5 Opening for camera

	BE	BFN	BEE	BEN	InMax 50.75-S	Joventa DAFx.20S
Y [mm]	111	97	97	93	161	126

Round MSD-W - design with spring return actuator with emergency function and electromagnet

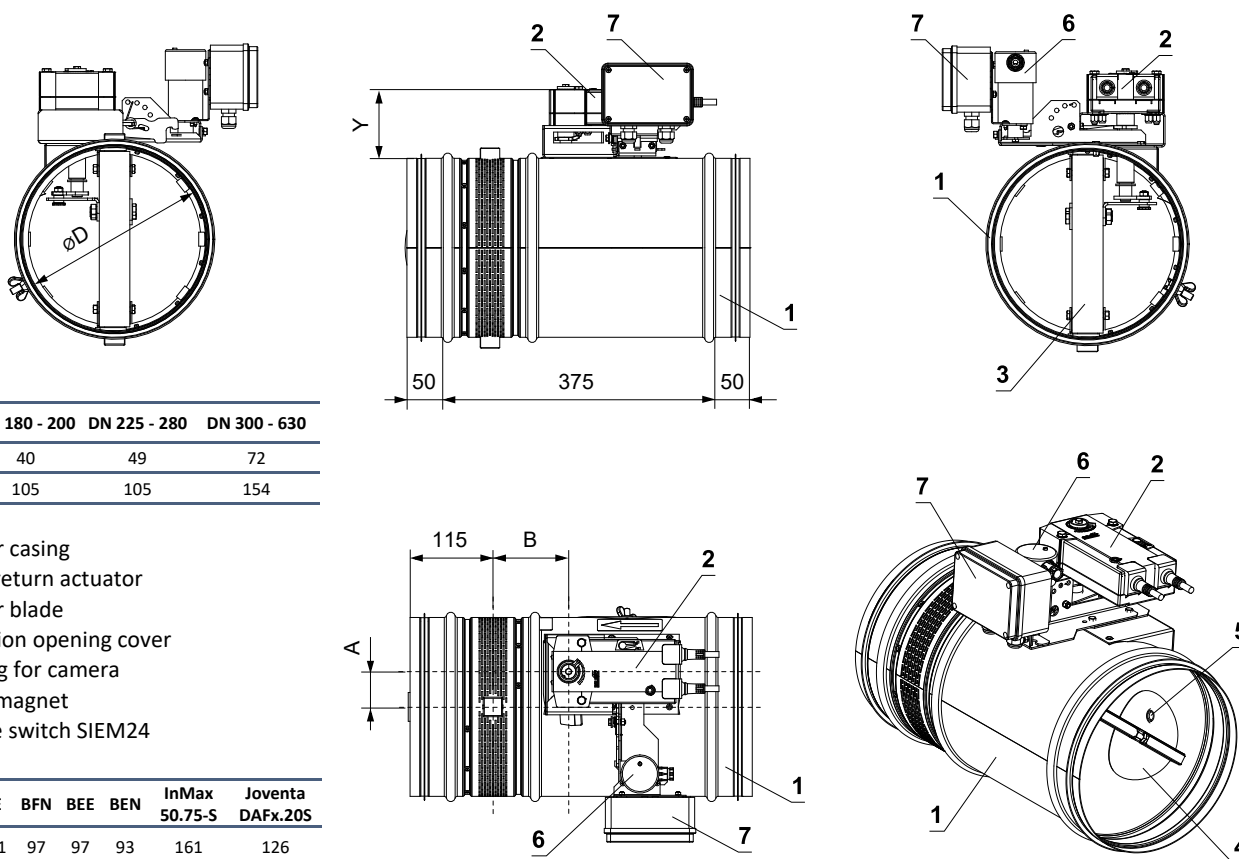

	DN 180 - 200	DN 225 - 280	DN 300 - 630
A [mm]	40	49	72
B [mm]	105	105	154

- 1 Damper casing
- 2 Spring return actuator
- 3 Damper blade
- 4 Inspection opening cover
- 5 Opening for camera
- 6 Electromagnet
- 7 Impulse switch SIEM24

	BE	BFN	BEE	BEN	InMax 50.75-S	Joventa DAFx.20S
Y [mm]	111	97	97	93	161	126

Damper blade overlaps

- Open damper blade overlaps the square damper casing by the value "a" or "c". These values are specified in chapter Technical parameters → see pages 18 to 27
- Open damper blade overlaps the round damper casing by the value "f". These values are specified in chapter Technical parameters → see page 28

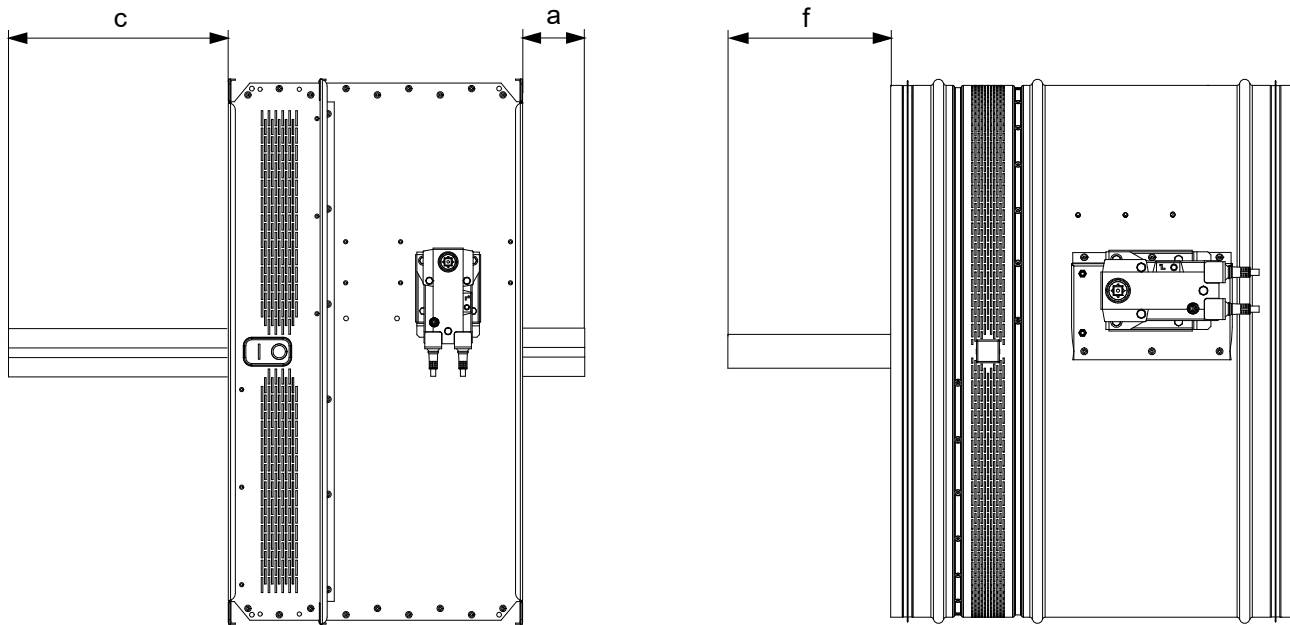

Values "a" ,"c" and "f" has to be respected when projecting following air-conditioning duct.

Flange of a damper

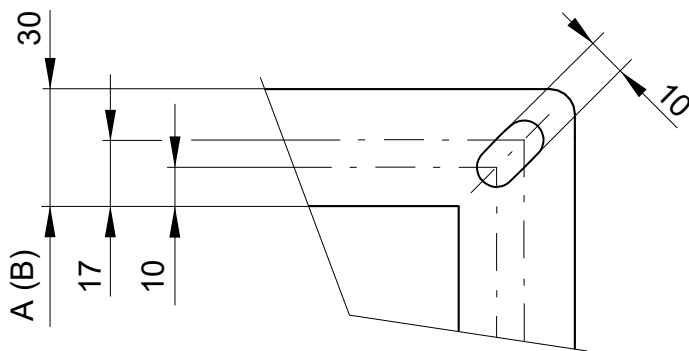

30 mm wide flanges are fitted with oval holes in the corners

Technical parameters

For square dampers

A x B [mm]	Damper blade overlaps		Free area S _f [m ²]	MSD-W		MSD-W with electromagnet		MSD	
	a [mm]	c [mm]		Weight [kg]	Spring return actuator	Weight [kg]	Spring return actuator	Weight [kg]	Spring return actuator
160 x	180	-	19	0,0162	9,3	11,7		17,4	
	200	-	29	0,0191	9,6	12,1		17,7	
	225	-	41,5	0,0228	9,9	12,6		18,1	
	250	-	54	0,0264	10,3	13,1		18,5	
	280	-	69	0,0307	10,7	13,8		19	
	300	-	79	0,0336	10,9	14,2		19,3	
	315	-	86,5	0,0358	11,1	14,5		19,5	
	355	-	106,5	0,0416	11,6	15,3		20,1	
	400	-	129	0,0481	12,2	16,3	BELIMO BFN	20,8	
	450	-	154	0,0554	12,9	17,3		21,6	
	500	-	179	0,0626	13,5	18,3	BELIMO BEN	22,3	BELIMO BEN
	550	-	204	0,0699	14,2	19,4		23,1	
	560	-	209	0,0713	14,3	19,6		23,3	
	600	-	229	0,0771	14,8	20,4		23,9	
	630	-	244	0,0815	15,2	21		24,3	
	650	9	254	0,0844	15,5	21,4		24,6	
	700	34	279	0,0916	16,1	24,3		25,4	
	710	39	284	0,0931	16,2	24,5	JOVENTA	25,5	
	750	59	304	0,0989	16,8	25,3	DAFx.20S	26,1	
	800	84	329	0,1061	17,4	26,4		26,9	
180 x	180	-	19	0,0185	9,6	12,1		17,8	
	200	-	29	0,0218	9,9	12,5		18,1	
	225	-	41,5	0,0259	10,3	13		18,5	
	250	-	54	0,0300	10,7	13,6		19	
	280	-	69	0,0350	11,1	14,2		19,5	
	300	-	79	0,0383	11,4	14,7		19,8	
	315	-	86,5	0,0408	11,6	15		20,1	
	355	-	106,5	0,0474	12,2	15,8		20,8	
	400	-	129	0,0548	12,9	16,8	BELIMO BFN	21,6	
	450	-	154	0,0630	13,6	17,9		22,4	
	500	-	179	0,0713	14,3	19	BELIMO BEN	23,3	BELIMO BEN
	550	-	204	0,0795	15,1	20,1		24,1	
	560	-	209	0,0812	15,2	20,3		24,3	
	600	-	229	0,0878	15,8	21,1		25	
	630	-	244	0,0927	16,2	21,8		25,5	
	650	9	254	0,0960	16,5	22,2		25,9	
	700	34	279	0,1043	17,2	25,1		26,7	
	710	39	284	0,1059	17,4	25,3	JOVENTA	26,9	
	750	59	304	0,1125	18	26,2	DAFx.20S	27,5	
	800	84	329	0,1208	18,7	27,3		28,4	
200 x	180	-	19	0,0207	9,9	12,4		18,1	
	200	-	29	0,0244	10,3	12,9		18,5	
	225	-	41,5	0,0290	10,7	13,4		19	
	250	-	54	0,0337	11,1	14		19,5	
	280	-	69	0,0392	11,6	14,7		20	
	300	-	79	0,0429	11,9	15,1		20,4	
	315	-	86,5	0,0457	12,1	15,5	BELIMO BFN	20,7	BELIMO BEN
	355	-	106,5	0,0531	12,8	16,4		21,5	
	400	-	129	0,0614	13,5	17,4		22,3	
	450	-	154	0,0707	14,3	18,5		23,3	
	500	-	179	0,0799	15,1	19,6		24,2	
	550	-	204	0,0892	16	20,8		25,2	

A x B [mm]	Damper blade overlaps		Free area S _f [m ²]	MSD-W		MSD-W with electromagnet		MSD	
	a [mm]	c [mm]		Weight [kg]	Spring return actuator	Weight [kg]	Spring return actuator	Weight [kg]	Spring return actuator
200 x	560	-	209	0,0910	16,1	21		25,4	
	600	-	229	0,0984	16,8	21,9	BELIMO BFN	26,1	
	630	-	244	0,1040	17,2	22,6		26,7	
	650	9	254	0,1077	17,6	23		27,1	BELIMO BEN
	700	34	279	0,1169	18,4	26		28	BELIMO BEN
	710	39	284	0,1188	18,5	26,2	JOVENTA	28,2	
	750	59	304	0,1262	19,2	27,1	DAFx.20S	29	
	800	84	329	0,1354	20	28,2		29,9	
225 x	180	-	19	0,0235	10,3	12,9		18,5	
	200	-	29	0,0277	10,7	13,3		19	
	225	-	41,5	0,0330	11,1	13,9		19,5	
	250	-	54	0,0382	11,6	14,5		20,1	
	280	-	69	0,0445	12,1	15,2		20,7	
	300	-	79	0,0487	12,5	15,7		21,1	
	315	-	86,5	0,0519	12,8	16,1	BELIMO BFN	21,5	
	355	-	106,5	0,0603	13,5	17		22,3	
	400	-	129	0,0697	14,3	18,1		23,3	
	450	-	154	0,0802	15,2	19,2		24,4	BELIMO BEN
	500	-	179	0,0907	16,2	20,4		25,4	BELIMO BEN
	550	-	204	0,1012	17,1	21,6		26,5	
	560	-	209	0,1033	17,2	21,8		26,7	
	600	-	229	0,1117	18	22,8		27,5	
	630	-	244	0,1180	18,5	25,3		28,2	
	650	9	254	0,1222	18,9	25,8		28,6	
	700	34	279	0,1327	19,8	26,9	JOVENTA	29,6	
	710	39	284	0,1348	19,9	27,2	DAFx.20S	29,9	
	750	59	304	0,1432	20,6	28,1		30,7	
	800	84	329	0,1537	21,5	29,3		31,7	
250 x	180	-	19	0,0263	10,7	13,3		19	
	200	-	29	0,0310	11,1	13,8		19,5	
	225	-	41,5	0,0369	11,6	14,4		20,1	
	250	-	54	0,0428	12,1	15,1		20,7	
	280	-	69	0,0498	12,7	15,8		21,4	
	300	-	79	0,0545	13,1	16,3		21,9	
	315	-	86,5	0,0580	13,4	16,6	BELIMO BFN	22,2	
	355	-	106,5	0,0674	14,2	17,6		23,2	
	400	-	129	0,0780	15,1	18,7		24,2	
	450	-	154	0,0898	16,2	19,9		25,4	BELIMO BEN
	500	-	179	0,1015	17,2	21,2		26,6	BELIMO BEN
	550	-	204	0,1133	18,2	22,4		27,8	
	560	-	209	0,1156	18,4	22,6		28	
	600	-	229	0,1250	19,2	25,4		29	
	630	-	244	0,1321	19,8	26,2		29,6	
	650	9	254	0,1368	20,2	26,7	JOVENTA	30,1	
	700	34	279	0,1485	21,1	27,9	DAFx.20S	31,3	
	710	39	284	0,1509	21,3	28,1		31,5	
	750	59	304	0,1603	22,1	29,1		32,4	
	800	84	329	0,1720	23,1	30,3		33,6	
280 x	180	-	19	0,0297	11,1	13,9		19,5	
	200	-	29	0,0350	11,6	14,4		20	
	225	-	42	0,0416	12,1	15		20,7	
	250	-	54	0,0482	12,7	15,7	BELIMO BFN	21,4	BELIMO BEN
	280	-	69	0,0562	13,4	16,4		22,2	
	300	-	79	0,0615	13,8	17		22,7	
315	-	86,5	0,0655	14,2	17,3		23,1		

A x B [mm]	Damper blade overlaps		Free area S _f [m ²]	MSD-W		MSD-W with electromagnet		MSD	
	a [mm]	c [mm]		Weight [kg]	Spring return actuator	Weight [kg]	Spring return actuator	Weight [kg]	Spring return actuator
280 x	355	-	106,5	0,0761	15,1	18,4		24,2	
	400	-	129	0,0880	16,1	19,5		25,4	
	450	-	154	0,1012	17,2	20,8	BELIMO BFN	26,7	
	500	-	179	0,1145	18,4	22,1		28	
	550	-	204	0,1277	19,5	23,3		29,3	
	560	-	209	0,1304	19,7	25,4		29,6	
	600	-	229	0,1410	20,6	26,4	BELIMO BEN	30,6	BELIMO BEN
	630	-	244	0,1489	21,3	27,2		31,4	
	650	9	254	0,1542	21,7	27,7	JOVENTA	31,9	
	700	34	279	0,1675	22,8	29	DAFx.20S	33,2	
	710	39	284	0,1701	23	29,2		33,5	
	750	59	304	0,1807	23,9	30,3		34,5	
	800	84	329	0,1940	25	31,5		35,8	
300 x	180	-	19	0,0319	11,4	14,2		19,8	
	200	-	29	0,0376	11,9	14,8		20,4	
	225	-	41,5	0,0447	12,5	15,4		21,1	
	250	-	54	0,0519	13,1	16,1		21,9	
	280	-	69	0,0604	13,8	16,9		22,7	
	300	-	79	0,0661	14,3	17,4	BELIMO BFN	23,3	
	315	-	86,5	0,0704	14,7	17,8		23,7	
	355	-	106,5	0,0818	15,7	18,9		24,9	
	400	-	129	0,0946	16,8	20		26,1	
	450	-	154	0,1089	18	21,3		27,5	
	500	-	179	0,1231	19,2	22,7	BELIMO BEN	29	BELIMO BEN
	550	-	204	0,1374	20,4	25,8		30,3	
	560	-	209	0,1402	20,6	26,1		30,6	
	600	-	229	0,1516	21,5	27,1		31,7	
	630	-	244	0,1602	22,3	27,9		32,6	
	650	9	254	0,1659	22,7	28,4	JOVENTA	33,1	
	700	34	279	0,1801	23,9	29,7	DAFx.20S	34,5	
	710	39	284	0,1830	24,1	30		34,8	
	750	59	304	0,1944	25,1	31		35,9	
800	84	329	0,2086	26,2	32,4		37,2		
315 x	180	-	19	0,0336	11,6	14,5		20,1	
	200	-	29	0,0396	12,1	15,1		20,7	
	225	-	41,5	0,0471	12,8	15,7		21,5	
	250	-	54	0,0546	13,4	16,4		22,2	
	280	-	69	0,0636	14,2	17,2		23,1	
	300	-	79	0,0696	14,7	17,8	BELIMO BFN	23,7	
	315	-	86,5	0,0741	15,1	18,2		24,2	
	355	-	106,5	0,0861	16,1	19,2		25,4	
	400	-	129	0,0996	17,2	20,4		26,7	
	450	-	154	0,1146	18,5	21,8		28,2	
	500	-	179	0,1296	19,8	23,1	BELIMO BEN	29,6	BELIMO BEN
	550	-	204	0,1446	21	26,3		31,1	
	560	-	209	0,1476	21,3	26,5		31,4	
	600	-	229	0,1596	22,3	27,6		32,6	
	630	-	244	0,1686	23	28,4		33,4	
	650	9	254	0,1746	23,5	28,9	JOVENTA	34	
	700	34	279	0,1896	24,7	30,3	DAFx.20S	35,5	
	710	39	284	0,1926	25	30,6		35,7	
	750	59	304	0,2046	26	31,6		36,9	
	800	84	329	0,2196	27,2	33		38,3	
355 x	180	-	19	0,0381	12,2	15,2	BELIMO BEN	20,8	BELIMO BEN
	200	-	29	0,0449	12,8	15,8	BELIMO BFN	21,5	BELIMO BEN

A x B [mm]	Damper blade overlaps		Free area S _f [m ²]	MSD-W		MSD-W with electromagnet		MSD	
	a [mm]	c [mm]		Weight [kg]	Spring return actuator	Weight [kg]	Spring return actuator	Weight [kg]	Spring return actuator
355 x	225	-	41,5	0,0534	13,5	16,5		22,3	
	250	-	54	0,0619	14,2	17,2		23,2	
	280	-	69	0,0721	15,1	18,1		24,2	
	300	-	79	0,0789	15,7	18,7		24,9	
	315	-	86,5	0,0840	16,1	19,1	BELIMO BFN	25,4	
	355	-	106,5	0,0976	17,2	20,2		26,7	
	400	-	129	0,1129	18,5	21,5		28,2	
	450	-	154	0,1299	19,9	22,9		29,9	
	500	-	179	0,1469	21,3	26,1		31,5	BELIMO BEN
	550	-	204	0,1639	22,7	27,5	BELIMO BEN	33,1	
	560	-	209	0,1673	23	27,8		33,5	
	600	-	229	0,1809	24,1	28,9		34,8	
	630	-	244	0,1911	25	29,8	JOVENTA	35,7	
	650	9	254	0,1979	25,5	30,4	DAFx.20S	36,4	
	700	34	279	0,2149	26,9	31,8		38	
	710	39	284	0,2183	27,2	32,1		38,3	
	750	59	304	0,2319	28,3	33,2		39,6	
800	84	329	0,2489	29,7	34,6		41,2	BELIMO BEE	
400 x	180	-	19	0,0431	12,9	16		21,6	
	200	-	29	0,0508	13,5	16,7		22,3	
	225	-	41,5	0,0604	14,3	17,4		23,3	
	250	-	54	0,0701	15,1	18,2		24,2	
	280	-	69	0,0816	16,1	19,1		25,4	
	300	-	79	0,0893	16,8	19,7	BELIMO BFN	26,1	
	315	-	86,5	0,0951	17,2	20,1		26,7	
	355	-	106,5	0,1105	18,5	21,3		28,2	
	400	-	129	0,1278	20	22,7		29,9	
	450	-	154	0,1471	21,5	24,2		31,7	BELIMO BEN
	500	-	179	0,1663	23,1	27,5	BELIMO BEN	33,6	
	550	-	204	0,1856	24,7	29		35,4	
	560	-	209	0,1894	25	29,3		35,8	
	600	-	229	0,2048	26,2	30,5		37,2	
	630	-	244	0,2164	27,2	31,4	JOVENTA	38,3	
	650	9	254	0,2241	27,8	31,9	DAFx.20S	39	
	700	34	279	0,2433	29,3	33,4		40,8	
710	39	284	0,2472	29,7	33,7		41,2		
750	59	304	0,2626	30,9	34,9		42,6		
800	84	329	0,2818	32,4	36,4		44,4	BELIMO BEE	
450 x	180	-	19	0,0487	13,6	17		22,4	
	200	-	29	0,0574	14,3	17,6		23,3	
	225	-	41,5	0,0683	15,2	18,4		24,4	
	250	-	54	0,0792	16,2	19,2		25,4	
	280	-	69	0,0922	17,2	20,2	BELIMO BFN	26,7	
	300	-	79	0,1009	18	20,8		27,5	
	315	-	86,5	0,1074	18,5	21,3		28,2	
	355	-	106,5	0,1248	19,9	22,6		29,9	
	400	-	129	0,1444	21,5	24	BELIMO BEN	31,7	BELIMO BEN
	450	-	154	0,1662	23,3	27,4		33,8	
	500	-	179	0,1879	25,1	29		35,9	
	550	-	204	0,2097	26,8	30,6		37,9	
	560	-	209	0,2140	27,2	30,9	JOVENTA	38,3	
	600	-	229	0,2314	28,6	32,1	DAFx.20S	39,9	
	630	-	244	0,2445	29,6	33,1		41,1	
	650	9	254	0,2532	30,3	33,7		41,9	
	700	34	279	0,2749	32	35,3		43,9	

A x B [mm]	Damper blade overlaps		Free area S _f [m ²]	MSD-W		MSD-W with electromagnet		MSD	
	a	c		Weight [kg]	Spring return actuator	Weight [kg]	Spring return actuator	Weight [kg]	Spring return actuator
	[mm]	[mm]							
450 x	710	39	284	0,2793	32,4	35,6		44,3	
	750	59	304	0,2967	33,7	17,2	BELIMO BEN	23,2	BELIMO BEN
	800	84	329	0,3184	35,4	18,1	JOVENTA DAFx.20S	24,2	BELIMO BEE
500 x	180	-	19	0,0543	14,3	18,7		24,9	
	200	-	29	0,0640	15,1	19,1		25,4	
	225	-	41,5	0,0761	16,2	20,2		26,7	
	250	-	54	0,0883	17,2	21,5		28,2	
	280	-	69	0,1028	18,4	22,9	BELIMO BFN	29,9	
	300	-	79	0,1125	19,2	26,1		31,5	
	315	-	86,5	0,1198	19,8	27,5		33,1	
	355	-	106,5	0,1392	21,3	27,8		33,5	
	400	-	129	0,1610	23,1	28,9		34,8	
	450	-	154	0,1853	25,1	29,8		35,7	BELIMO BEN
	500	-	179	0,2095	27	30,4		36,4	
	550	-	204	0,2338	29	31,8		38	
	560	-	209	0,2386	29,3	32,1		38,3	
	600	-	229	0,2580	30,9	33,2		39,6	
	630	-	244	0,2726	32	34,6	JOVENTA DAFx.20S	41,2	
	650	9	254	0,2823	32,8	16		21,6	
	700	34	279	0,3065	34,7	16,7		22,3	
710	39	284	0,3114	35,1	17,4		23,3		
750	59	304	0,3308	36,6	18,2		24,2		
800	84	329	0,3550	38,4	19,1		25,4	BELIMO BEE	
550 x	180	-	19	0,0599	15,1	19,7		26,1	
	200	-	29	0,0706	16	20,1		26,7	
	225	-	41,5	0,0840	17,1	21,3		28,2	
	250	-	54	0,0974	18,2	22,7		29,9	
	280	-	69	0,1134	19,5	24,2	BELIMO BFN	31,7	
	300	-	79	0,1241	20,4	27,5		33,6	
	315	-	86,5	0,1321	21	29		35,4	
	355	-	106,5	0,1535	22,7	29,3		35,8	
	400	-	129	0,1776	24,7	30,5		37,2	
	450	-	154	0,2044	26,8	31,4		38,3	BELIMO BEN
	500	-	179	0,2311	29	31,9		39	
	550	-	204	0,2579	31,1	33,4		40,8	
	560	-	209	0,2632	31,5	33,7		41,2	
	600	-	229	0,2846	33,2	34,9	JOVENTA DAFx.20S	42,6	
	630	-	244	0,3007	34,4	36,4		44,4	
	650	9	254	0,3114	35,2	17		22,4	
	700	34	279	0,3381	37,3	17,6		23,3	
710	39	284	0,3435	37,7	18,4		24,4		
750	59	304	0,3649	39,4	19,2		25,4		
800	84	329	0,3916	41,4	20,2		26,7	BELIMO BEE	
560 x	180	-	19	0,0610	15,2	20,8		27,5	
	200	-	29	0,0719	16,1	21,3		28,2	
	225	-	42	0,0856	17,2	22,6		29,9	
	250	-	54	0,0992	18,4	24		31,7	
	280	-	69	0,1155	19,7	27,4	BELIMO BFN	33,8	
	300	-	79	0,1264	20,6	29		35,9	
	315	-	87	0,1346	21,3	30,6		37,9	BELIMO BEN
	355	-	106,5	0,1564	23	30,9		38,3	
	400	-	129	0,1809	25	32,1		39,9	
	450	-	154	0,2082	27,2	33,1	JOVENTA DAFx.20S	41,1	
	500	-	179	0,2354	29,3	33,7		41,9	
	550	-	204	0,2627	31,5	35,3		43,9	

A x B [mm]	Damper blade overlaps		Free area S _f [m ²]	MSD-W		MSD-W with electromagnet		MSD			
	a [mm]	c [mm]		Weight [kg]	Spring return actuator	Weight [kg]	Spring return actuator	Weight [kg]	Spring return actuator		
560 x	560	–	209	0,2681	31,9			34,4		43,8	
	600	–	229	0,2899	33,6			35,8		45,8	
	630	–	244	0,3063	34,9			36,9		47,2	
	650	9	254	0,3172	35,7	BELIMO BEN		37,6	JOVENTA	48,2	BELIMO BEN
	700	34	279	0,3444	37,8			39,4	DAFx.20S	50,6	
	710	39	284	0,3499	38,3			39,7		51,1	
	750	59	304	0,3717	39,9			41,2		53	
	800	84	329	0,3989	42			42,9		55,4	BELIMO BEE
600 x	180	–	19	0,0655	15,8			19,7		25	
	200	–	29	0,0772	16,8			20,5		26,1	
	225	–	41,5	0,0918	18			21,4		27,5	
	250	–	54	0,1065	19,2			22,4	BELIMO BFN	29	
	280	–	69	0,1240	20,6			23,5			30,6
	300	–	79	0,1357	21,5			24,2		31,7	
	315	–	86,5	0,1445	22,3			24,8		32,6	
	355	–	106,5	0,1679	24,1			26,3		34,8	
	400	–	129	0,1942	26,2			29,8		37,2	BELIMO BEN
	450	–	154	0,2235	28,6	BELIMO BEN		31,6		39,9	
	500	–	179	0,2527	30,9			33,5		42,6	
	550	–	204	0,2820	33,2			35,3		45,3	
	560	–	209	0,2878	33,6			35,7		45,8	
	600	–	229	0,3112	35,4			37,2	JOVENTA	47,9	
	630	–	244	0,3288	36,8			38,3	DAFx.20S	49,4	
	650	9	254	0,3405	37,7			39		50,5	
	700	34	279	0,3697	39,9			40,9		53	
	710	39	284	0,3756	40,4			41,2		53,5	
750	59	304	0,3990	42,1			42,7		55,6	BELIMO BEE	
800	84	329	0,4282	44,3			44,6		58,1		
630 x	180	–	19	0,0689	16,2			20,2		25,5	
	200	–	29	0,0812	17,2			21,1		26,7	
	225	–	41,5	0,0966	18,5			22		28,2	
	250	–	54	0,1119	19,8			23	BELIMO BFN	29,6	
	280	–	69	0,1304	21,3			24,1			31,4
	300	–	79	0,1427	22,3			24,9		32,6	
	315	–	86,5	0,1519	23			25,5		33,4	
	355	–	106,5	0,1765	25			27		35,7	
	400	–	129	0,2042	27,2			30,5		38,3	BELIMO BEN
	450	–	154	0,2349	29,6	BELIMO BEN		32,4		41,1	
	500	–	179	0,2657	32			34,4		43,9	
	550	–	204	0,2964	34,4			36,3		46,7	
	560	–	209	0,3026	34,9			36,6		47,2	
	600	–	229	0,3272	36,8			38,2	JOVENTA	49,4	
	630	–	244	0,3456	38,2			39,3	DAFx.20S	51,1	
	650	9	254	0,3579	39,1			40,1		52,1	
	700	34	279	0,3887	41,5			42		54,8	
	710	39	284	0,3948	41,9			42,4		55,3	
750	59	304	0,4194	43,8			43,9		57,4	BELIMO BEE	
800	84	329	0,4502	46,1			45,8		60,1	BELIMO BE	
650 x	180	–	19	0,0711	16,5			20,6		25,9	
	200	–	29	0,0838	17,6			21,4		27,1	
	225	–	41,5	0,0997	18,9			22,5		28,6	
	250	–	54	0,1156	20,2	BELIMO BEN		23,4	BELIMO BFN	30,1	BELIMO BEN
	280	–	69	0,1346	21,7			24,6		31,9	
	300	–	79	0,1473	22,7			25,4		33,1	
315	–	86,5	0,1568	23,5			25,9		34		

A x B [mm]	Damper blade overlaps		Free area S _f [m ²]	MSD-W		MSD-W with electromagnet		MSD	
	a [mm]	c [mm]		Weight [kg]	Spring return actuator	Weight [kg]	Spring return actuator	Weight [kg]	Spring return actuator
650 x	355	-	106,5	0,1822	25,5	34,4	BELIMO BFN	39	
	400	-	129	0,2108	27,8	31,1		41,9	
	450	-	154	0,2426	30,3	33		44,8	
	500	-	179	0,2743	32,8	35		47,7	
	550	-	204	0,3061	35,2	36,9		48,2	BELIMO BEN
	560	-	209	0,3124	35,7	37,3		50,5	
	600	-	229	0,3378	37,7	BELIMO BEN	38,8	JOVENTA	52,1
	630	-	244	0,3569	39,1		40	DAFx.20S	53,2
	650	9	254	0,3696	40,1		40,8		56
	700	34	279	0,4013	42,5		42,7		56,5
	710	39	284	0,4077	43		43,1		58,7
	750	59	304	0,4331	44,9		44,7		61,4
800	84	329	0,4648	47,2		46,6		26,7	
								BELIMO BE	
700 x	180	-	19	0,0767	17,2	21,5		28	
	200	-	29	0,0904	18,4	22,4		29,6	
	225	-	41,5	0,1075	19,8	23,5		31,3	
	250	-	54	0,1247	21,1	24,5	BELIMO BFN	33,2	
	280	-	69	0,1452	22,8	25,7		34,5	
	300	-	79	0,1589	23,9	26,5		35,5	
	315	-	86,5	0,1692	24,7	27,1		38	
	355	-	106,5	0,1966	26,9	30,6		40,8	BELIMO BEN
	400	-	129	0,2274	29,3	32,4		43,9	
	450	-	154	0,2617	32	34,4		47	
	500	-	179	0,2959	34,7	BELIMO BEN	36,4		50
	550	-	204	0,3302	37,3		38,5		50,6
	560	-	209	0,3370	37,8		38,9		53
	600	-	229	0,3644	39,9		40,5	JOVENTA	54,8
	630	-	244	0,3850	41,5		41,7	DAFx.20S	56
	650	9	254	0,3987	42,5		42,5		58,9
	700	34	279	0,4329	45,1		44,6		59,5
	710	39	284	0,4398	45,6		45		61,8
750	59	304	0,4672	47,6		46,6		64,6	
800	84	329	0,5014	50,1		48,6		26,9	
								BELIMO BE	
710 x	180	-	19	0,0778	17,4	21,7		28,2	
	200	-	29	0,0917	18,5	22,6		29,9	
	225	-	41,5	0,1091	19,9	23,7		31,5	
	250	-	54	0,1265	21,3	24,7	BELIMO BFN	33,5	
	280	-	69	0,1473	23	25,9		34,8	
	300	-	79	0,1612	24,1	26,7		35,7	
	315	-	86,5	0,1717	25	27,3		38,3	
	355	-	106,5	0,1995	27,2	30,8		41,2	BELIMO BEN
	400	-	129	0,2307	29,7	32,6		44,3	
	450	-	154	0,2655	32,4	34,7		47,4	
	500	-	179	0,3002	35,1	BELIMO BEN	36,7		50,5
	550	-	204	0,3350	37,7		38,8		51,1
	560	-	209	0,3419	38,3		39,2		53,5
	600	-	229	0,3697	40,4		40,8	JOVENTA	55,3
	630	-	244	0,3906	41,9		42,1	DAFx.20S	56,5
	650	9	254	0,4045	43		42,9		59,5
	700	34	279	0,4392	45,6		45		60,1
	710	39	284	0,4462	46,1		45,4		62,4
750	59	304	0,4740	48,1		47		65,3	
800	84	329	0,5087	50,6		49,1		27,5	
								BELIMO BE	
750 x	180	-	19	0,0823	18	BELIMO BEN	22,4	29	BELIMO BEN
	200	-	29	0,0970	19,2		23,3	BELIMO BFN	34

A x B [mm]	Damper blade overlaps		Free area S _f [m ²]	MSD-W		MSD-W with electromagnet		MSD	
	a [mm]	c [mm]		Weight [kg]	Spring return actuator	Weight [kg]	Spring return actuator	Weight [kg]	Spring return actuator
750 x	225	-	41,5	0,1154	20,6	24,5		30,7	
	250	-	54	0,1338	22,1	25,5		32,4	
	280	-	69	0,1558	23,9	26,8	BELIMO BFN	34,5	
	300	-	79	0,1705	25,1	27,6		35,9	
	315	-	86,5	0,1815	26	28,3		36,9	
	355	-	106,5	0,2109	28,3	31,8		39,6	
	400	-	129	0,2440	30,9	33,7		42,6	BELIMO BEN
	450	-	154	0,2808	33,7	35,8		45,9	
	500	-	179	0,3175	36,6	37,9		49,2	
	550	-	204	0,3543	39,4	40,1		52,4	
	560	-	209	0,3616	39,9	40,5		53	
	600	-	229	0,3910	42,1	42,2	JOVENTA DAFx.20S	55,6	
	630	-	244	0,4131	43,8	43,5		57,4	
	650	9	254	0,4278	44,9	44,3		58,7	
	700	34	279	0,4645	47,6	46,4		61,8	BELIMO BEE
	710	39	284	0,4719	48,1	46,9		62,4	
	750	59	304	0,5013	50,3	48,6		64,8	BELIMO BE
	800	84	329	0,5380	52,9	50,7		67,8	
800 x	180	-	19	0,0879	18,7	23,3		28,4	
	200	-	29	0,1036	20	24,3		29,9	
	225	-	41,5	0,1232	21,5	25,5		31,7	
	250	-	54	0,1429	23,1	26,6	BELIMO BFN	33,6	
	280	-	69	0,1664	25	27,9		35,8	
	300	-	79	0,1821	26,2	28,8		37,2	
	315	-	86,5	0,1939	27,2	29,4		38,3	
	355	-	106,5	0,2253	29,7	33		41,2	BELIMO BEN
	400	-	129	0,2606	32,4	35		44,4	
	450	-	154	0,2999	35,4	37,2		47,9	
	500	-	179	0,3391	38,4	39,4	BELIMO BEN	51,3	
	550	-	204	0,3784	41,4	41,7		54,7	
	560	-	209	0,3862	42	42,1		55,4	
	600	-	229	0,4176	44,3	43,9	JOVENTA DAFx.20S	58,1	
	630	-	244	0,4412	46,1	45,2		60,1	
	650	9	254	0,4569	47,2	46,1		61,4	BELIMO BEE
	700	34	279	0,4961	50,1	48,3		64,6	
	710	39	284	0,5040	50,6	48,7		65,3	
750	59	304	0,5354	52,9	50,5		67,8	BELIMO BE	
800	84	329	0,5746	55,7	52,7		71		
900 x	180	-	19	0,0991	20,1	25,1		30,1	
	200	-	29	0,1168	21,5	26,2		31,7	
	225	-	42	0,1389	23,3	27,5		33,8	
	250	-	54	0,1611	25,1	28,7	BELIMO BFN	35,9	
	280	-	69	0,1876	27,2	30,1		38,3	
	300	-	79	0,2053	28,6	31		39,9	
	315	-	86,5	0,2186	29,6	33,6		41,1	
	355	-	106,5	0,2540	32,4	35,5		44,3	
	400	-	129	0,2938	35,4	37,7	BELIMO BEN	47,9	
	450	-	154	0,3381	38,8	40		51,7	
	500	-	179	0,3823	42,1	42,4		55,6	
	550	-	204	0,4266	45,4	44,8	JOVENTA DAFx.20S	59,3	
	560	-	209	0,4354	46,1	45,3		60,1	
	600	-	229	0,4708	48,7	47,2		63	
	630	-	244	0,4974	50,6	48,7		65,2	BELIMO BEE
	650	9	254	0,5151	51,9	49,6		66,6	
	700	34	279	0,5593	55	52		70,2	BELIMO BE

A x B [mm]	Damper blade overlaps		Free area S _f [m ²]	MSD-W		MSD-W with electromagnet		MSD		
	a [mm]	c [mm]		Weight [kg]	Spring return actuator	Weight [kg]	Spring return actuator	Weight [kg]	Spring return actuator	
900 x	710	39	284	0,5682	55,6			52,5	70,9	
	750	59	304	0,6036	58,1	BELIMO BEN		54,4	73,7	BELIMO BE
	800	84	329	0,6478	61,2			56,8	77,1	
1000 x	180	-	19	0,1103	21,5			26,9	31,7	
	200	-	29	0,1300	23,1			28,1	33,6	
	225	-	42	0,1546	25,1			29,5	35,9	
	250	-	54	0,1793	27			30,8	38,1	
	280	-	69	0,2088	29,3			32,4	40,8	
	300	-	79	0,2285	30,9			35,2	42,6	BELIMO BEN
	315	-	86,5	0,2433	32			36	43,9	
	355	-	106,5	0,2827	35,1			38,1	47,4	
	400	-	129	0,3270	38,4			40,5	51,3	
	450	-	154	0,3763	42,1			43,1	55,6	
	500	-	179	0,4255	45,8	BELIMO BEN		45,7	59,7	
	550	-	204	0,4748	49,4			48,3	63,8	
	560	-	209	0,4846	50,1			48,8	64,6	
	600	-	229	0,5240	52,9			50,9	67,8	BELIMO BEE
	630	-	244	0,5536	55			52,5	70,2	
	650	9	254	0,5733	56,4			53,5	71,7	
	700	34	279	0,6225	59,8			56,2	75,6	
710	39	284	0,6324	60,5			56,7	76,4	BELIMO BE	
750	59	304	0,6718	63,2			58,8	79,4		
800	84	329	0,7210	66,5			61,4	83,1		
1100 x	180	-	19	0,1215	23			28,7	33,4	
	200	-	29	0,1432	24,7			30	35,4	
	225	-	41,5	0,1703	26,8			31,5	37,9	
	250	-	54	0,1975	29			32,9	40,4	
	280	-	69	0,2300	31,5			34,6	43,3	
	300	-	79	0,2517	33,2			37,5	45,3	BELIMO BEN
	315	-	86,5	0,2680	34,4			38,3	46,7	
	355	-	106,5	0,3114	37,7			40,6	50,5	
	400	-	129	0,3602	41,4			43,1	54,7	
	450	-	154	0,4145	45,4			45,9	59,3	
	500	-	179	0,4687	49,4	BELIMO BEN		48,7	63,8	
	550	-	204	0,5230	53,3			51,5	68,2	
	560	-	209	0,5338	54			52	69,1	
	600	-	229	0,5772	57,1			54,3	72,5	BELIMO BEE
	630	-	244	0,6098	59,4			56	75,1	
	650	9	254	0,6315	60,9			57,1	76,7	
	700	34	279	0,6857	64,6			59,9	80,9	
710	39	284	0,6966	65,3			60,4	81,7	BELIMO BE	
750	59	304	0,7400	68,2			62,7	84,9		
800	84	329	0,7942	71,8			65,5	88,8		
1250 x	180	-	19	0,1383	25,1			31,4	35,9	
	200	-	29	0,1630	27			32,8	38,1	
	225	-	41,5	0,1939	29,4			34,5	40,9	
	250	-	54	0,2248	31,8			36	43,7	
	280	-	69	0,2618	34,7			39,7	47	
	300	-	79	0,2865	36,6			40,9	49,2	BELIMO BEN
	315	-	87	0,3050	38	BELIMO BEN		41,8	50,8	
	355	-	106,5	0,3544	41,7			44,3	55	
	400	-	129	0,4100	45,8			47	59,7	
	450	-	154	0,4718	50,3			50,1	64,8	
	500	-	179	0,5335	54,7			53,2	69,8	
	550	-	204	0,5953	59			56,2	74,6	BELIMO BEE

A x B [mm]	Damper blade overlaps		Free area S _f [m ²]	MSD-W		MSD-W with electromagnet		MSD	
	a [mm]	c [mm]		Weight [kg]	Spring return actuator	Weight [kg]	Spring return actuator	Weight [kg]	Spring return actuator
1250 x	560	–	209	0,6076	59,8	56,8		75,6	
	600	–	229	0,6570	63,2	59,3		79,4	
	630	–	244	0,6941	65,7	61,1		82,1	
	650	9	254	0,7188	67,4	62,4	JOVENTA	84	BELIMO BE
	700	34	279	0,7805	71,4	65,4	DAFx.20S	88,5	
	710	39	284	0,7929	72,2	66,1		89,3	
	750	59	304	0,8423	75,4	68,5		92,8	
	800	84	329	0,9040	79,3	71,6		97,1	
180	–	19	0,1551	27,2	34,2		38,3		
200	–	29	0,1828	29,3	35,7	BELIMO BFN	40,8		
225	–	41,5	0,2174	32	37,5		43,9		
1400 x	250	–	54	0,2521	34,7	41		47	
	280	–	69	0,2936	37,8	43		50,6	BELIMO BEN
	300	–	79	0,3213	39,9	44,3		53	
	315	–	86,5	0,3421	41,5	45,3		54,8	
	355	–	106,5	0,3975	45,6	48		59,5	
	400	–	129	0,4598	50,1	51		64,6	
	450	–	154	0,5291	55	54,3		70,2	
	500	–	179	0,5983	59,8	57,7	BELIMO BEN	75,6	BELIMO BEE
	550	–	204	0,6676	64,6	61	JOVENTA	80,9	
	560	–	209	0,6814	65,5	61,7	DAF2.20S	81,9	
	600	–	229	0,7368	69,2	64,3		86	
	630	–	244	0,7784	71,9	66,3		88,9	
	650	9	254	0,8061	73,7	67,7		90,9	BELIMO BE
	700	34	279	0,8753	78,1	71		95,7	
	710	39	284	0,8892	79	71,7		96,7	
	750	59	304	0,9446	82,4	74,3		100,4	
800	84	329	1,0138	86,6	77,7		104,9	SCHISCHEK InMax 50.75	
1500 x	180	–	19	0,1663	28,6	36		39,9	
	200	–	29	0,1960	30,9	37,6	BELIMO BFN	42,6	
	225	–	42	0,2331	33,7	39,5		45,9	
	250	–	54	0,2703	36,6	43,1		49,2	
	280	–	69	0,3148	39,9	45,2		53	BELIMO BEN
	300	–	79	0,3445	42,1	46,6		55,6	
	315	–	86,5	0,3668	43,8	47,6		57,4	
	355	–	106,5	0,4262	48,1	50,4		62,4	
	400	–	129	0,4930	52,9	53,6		67,8	
	450	–	154	0,5673	58,1	57,1		73,7	
	500	–	179	0,6415	63,2	60,6	BELIMO BEN	79,4	BELIMO BEE
	550	–	204	0,7158	68,2	64,2	JOVENTA	84,9	
	560	–	209	0,7306	69,2	64,9	DAFx.20S	86	
	600	–	229	0,7900	73,1	67,7		90,2	
	630	–	244	0,8346	75,9	69,8		93,3	
	650	9	254	0,8643	77,8	71,2		95,4	BELIMO BE
	700	34	279	0,9385	82,4	74,7		100,4	
	710	39	284	0,9534	83,3	75,4		101,3	
	750	59	304	1,0128	86,9	78,2		105,2	
	800	84	329	1,0870	91,3	81,6	JOVENTA DAF2.20S	109,8	SCHISCHEK InMax 50.75

For round dampers

Nominal size ØD [mm]	Damper blade overlaps f [mm]	Free area Sf [m ²]	MSD-W with electromagnet		MSD	
			Weight [kg]	Spring return actuator	Weight [kg]	Spring return actuator
180	–	0,0160	11,3		5,9	
200	–	0,0208	11,7		6,4	
225	–	0,0277	12,2		7	
250	2,5	0,0356	12,9	BELIMO BFN	7,7	
280	17,5	0,0463	13,6		8,6	
315	35	0,0607	14,6		9,7	
355	55	0,0794	15,8		10,9	BELIMO BEN
400	77,5	0,1035	15,6		12,4	
450	102,5	0,1339	17,3		14,2	
500	127,5	0,1683	19,2	JOVENTA DAFx.20S	16	
560	157,5	0,2148	21,7		18,3	
630	192,5	0,2762	24,8		21,2	

IV. INSTALLATION

Placement and installation

- Dampers are designed to remove heat and combustion products (e.g. smoke) from fire compartments.
- Dampers are suitable for installation in vertical and horizontal position passages of fire separating constructions. The damper installation procedures must be done so that all load transfer from the fire separating constructions to the damper is absolutely excluded.
- Following air-conditioning duct must be suspended or supported so that all load transfer from the following duct to the damper flange is absolutely excluded.
- The gap between the installed damper and the fire separating construction must be perfectly filled with approved material.
- After installing the damper, the damper blades must only be opened, or closed by operation of the actuator only.
- The distance between the damper and the construction (wall, ceiling) must be 75 mm at the minimum, according to EN 1366-2. If two or more dampers are to be installed in one fire separating construction, the distance between adjacent dampers must be 200 mm at the minimum, according to EN 1366-10.
- To provide the necessary space for access to the control device, it is recommended that other objects be at least 350 mm away from the control parts of the damper device, it is recommended that other objects be at least 350 mm away from the control parts of the damper.

Minimum distance between the dampers and the construction (applies to both round and square dampers)

- minimum distance 200 mm between dampers, according to EN 1366-10
- minimum distance 75 mm between damper and construction (wall/ceiling), according to EN 1366-10

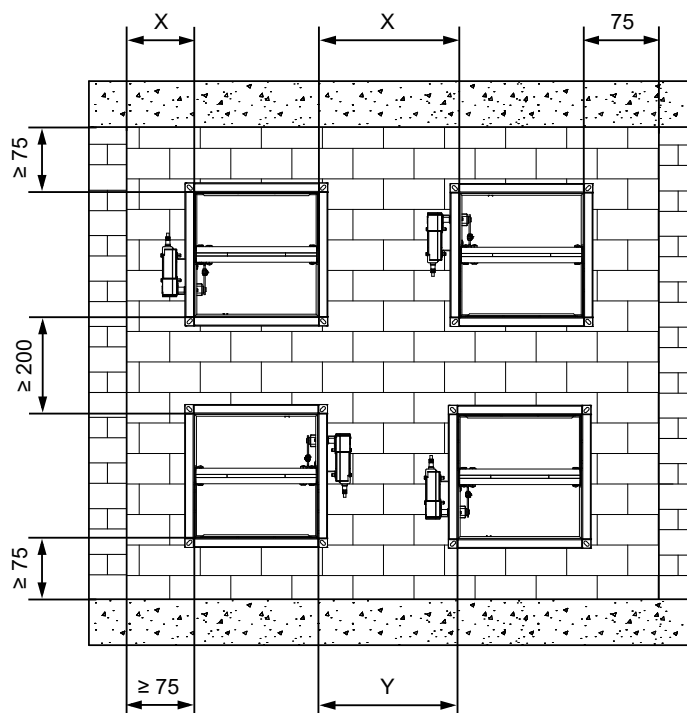

X = recommended minimum distance for a square damper with actuator ≥ 200 mm
 X = recommended minimum distance for a square damper with actuator and box ≥ 400 mm
 X = recommended minimum distance for a round damper with actuator ≥ 200 mm

Y = recommended minimum distance for a square damper with actuator ≥ 380 mm
 Y = recommended minimum distance for a square damper with actuator and box ≥ 700 mm
 Y = recommended minimum distance for a round damper with actuator ≥ 350 mm

Built in edge

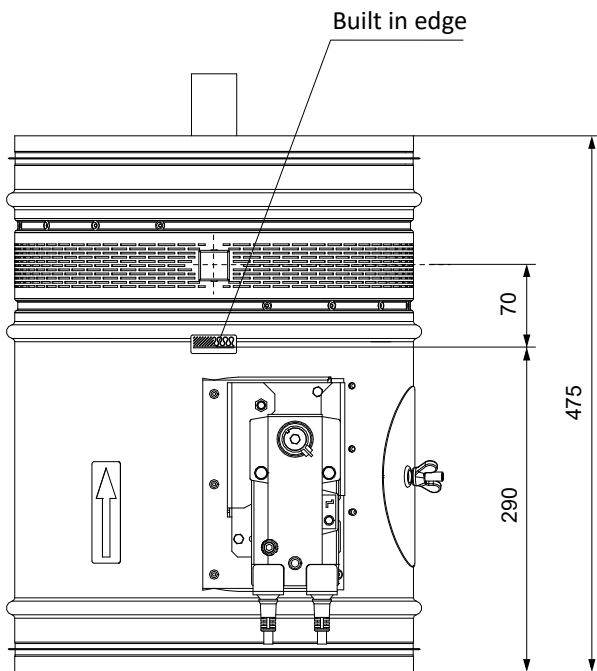
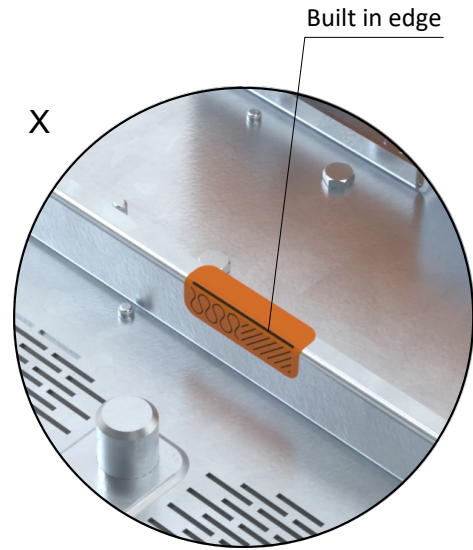
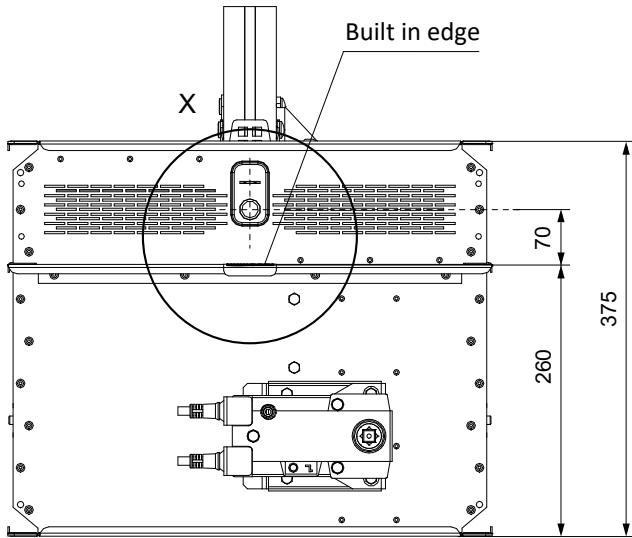

Dimensions of an installation opening

Dimensions of an installation opening - square dampers

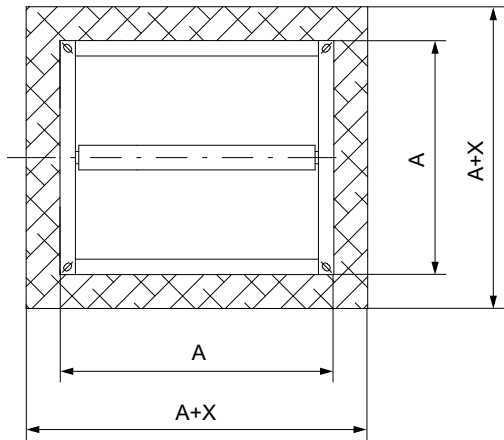

Mortar or gypsum

- X = min. 50 mm
- X = max. 150 mm

Ablative Coated Batt

- X = min. 50 mm
- X = max. 200 mm

Dimensions of an installation opening - round dampers

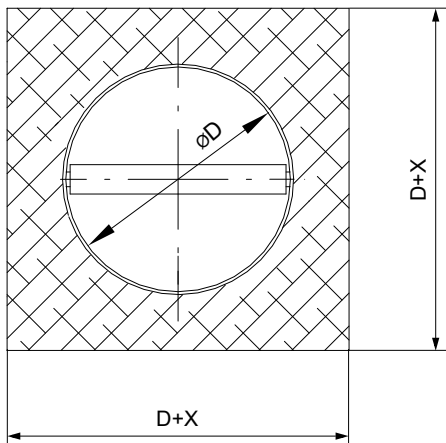

Mortar or gypsum

- X = min. 50 mm
- X = max. 150 mm

Statement of installations

Fire separating construction, location of the damper	Shape of the damper	Damper in section	Installation type, installation system	Gap width [mm]	Classification	Page
Standard low- and high-density rigid wall construction according to EN 1363-1 <ul style="list-style-type: none"> damper in the wall 125 mm min. wall thickness 	Round	SINGLE	Mortar or gypsum	50-150	EI 120 (V _{ew}) S1500[H]C ₁₀₀₀₀ AAmulti	33
		MULTI			EI 120 (V _{ew}) S1500[H]C _{mod} HOT400/30AAmulti * EI 120 (V _{ew}) S1500[H]C ₁₀₀₀₀ AAmulti	34
Standard low- and high-density rigid wall construction according to EN 1363-1 <ul style="list-style-type: none"> damper in the wall 100 mm min. wall thickness 	Square	MULTI	Mortar or gypsum	50-150	EI 120 (V _{ew}) S1500[H]C _{mod} HOT400/30AAmulti	35
		SINGLE			Ablative Coated Batt	50-200
		MULTI	EI 120 (V _{ew}) S1500[H]C _{mod} HOT400/30AAmulti	37		
		SINGLE	EI 120 (V _{ew}) S1500[H]C _{mod} HOT400/30AAmulti * EI 120 (V _{ew}) S1500[H]C ₁₀₀₀₀ AAmulti	38		
Standard flexible wall construction min. EI 90 according to EN 1363-1 <ul style="list-style-type: none"> damper in the wall 125 mm min. wall thickness 	Round	SINGLE	Mortar or gypsum	50-150	EI 120 (V _{ew}) S1500[H]C _{mod} HOT400/30AAmulti * EI 120 (V _{ew}) S1500[H]C ₁₀₀₀₀ AAmulti	39
		MULTI			EI 120 (V _{ew}) S1500[H]C _{mod} HOT400/30AAmulti	40
		SINGLE	Ablative Coated Batt	50-200	EI 120 (V _{ew}) S1500[H]C _{mod} HOT400/30AAmulti * EI 120 (V _{ew}) S1500[H]C ₁₀₀₀₀ AAmulti	41
		MULTI			EI 120 (V _{ew}) S1500[H]C _{mod} HOT400/30AAmulti	42
Standard low- and high-density rigid floor construction according to EN 1366-2 <ul style="list-style-type: none"> damper in the ceiling 150 mm min. ceiling thickness 	Round	SINGLE	Mortar or gypsum	50-150	EI 120 (h _{ow}) S1500[H]C ₁₀₀₀₀ AAmulti	43
		SINGLE			EI 120 (h _{ow}) S1500[H]C _{mod} HOT400/30AAmulti * EI 120 (h _{ow}) S1500[H]C ₁₀₀₀₀ AAmulti	44
	Square	MULTI	EI 120 (h _{ow}) S1500[H]C _{mod} HOT400/30AAmulti	45		
		SINGLE	Ablative Coated Batt	50-200	EI 90 (h _{ow}) S1500[H]C _{mod} HOT400/30AAmulti E 120 (h _{ow}) S1500[H]C _{mod} HOT400/30AAmulti * EI 120 (h _{ow}) S1500[H]C ₁₀₀₀₀ AAmulti	46
		MULTI			EI 90 (h _{ow}) S1500[H]C _{mod} HOT400/30AAmulti E 120 (h _{ow}) S1500[H]C _{mod} HOT400/30AAmulti	47
		Horizontal or vertical smoke extraction ducts tested according to EN 1366-8 or EN 1366-9 <ul style="list-style-type: none"> Into or onto the duct 	Square	MULTI	Damper installed into or onto a duct	N/A

* Applies to MSD-W damper

In solid wall construction

**In solid wall construction - mortar or gypsum
- damper placement in a single section**

EI 120 (v_{ew}) S1500[H]C₁₀₀₀₀AAmulti

- Standard low- and high-density rigid wall construction according to EN 1363-1
- For connection of following duct → see page 52

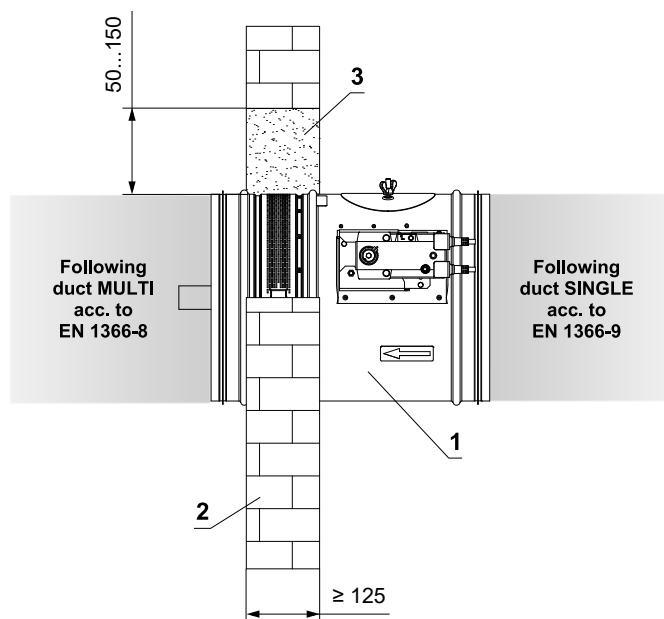
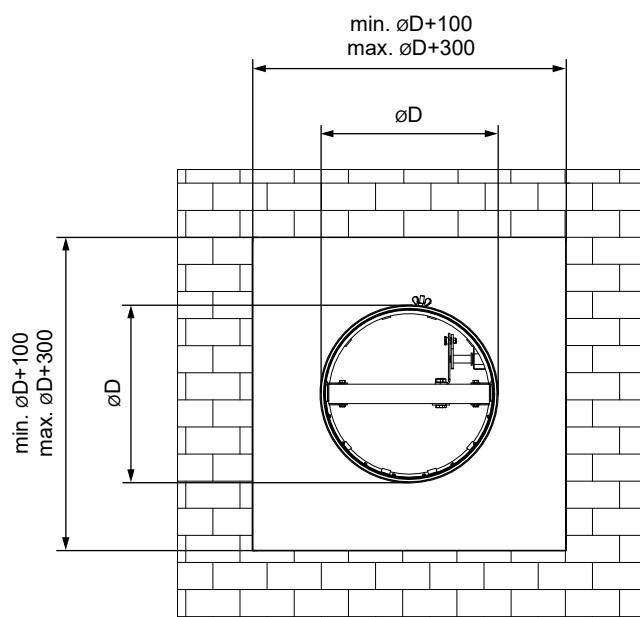
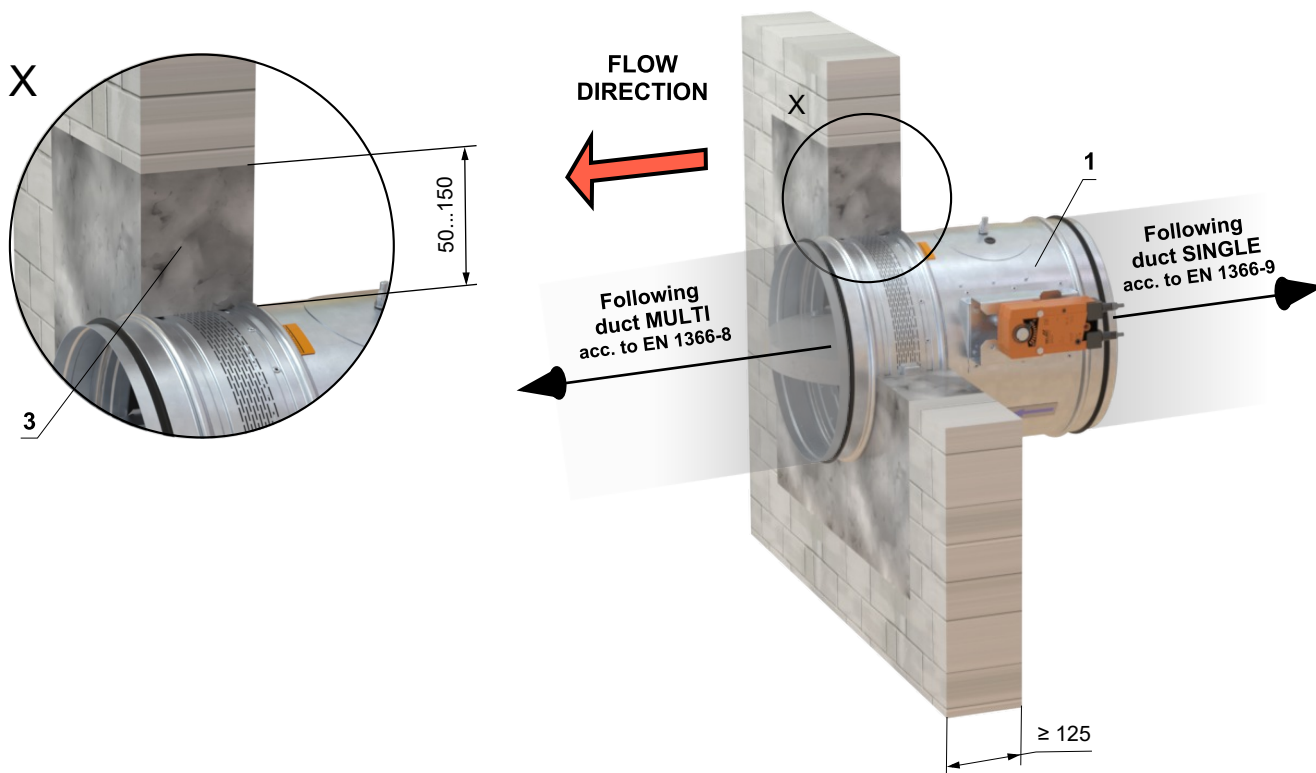

- 1 MSD-W / MSD - design „A“
- 2 Solid wall construction
- 3 Mortar or gypsum

**In solid wall construction - mortar or gypsum
- damper placement in a single section**

**EI 120 (v_{ew}) S1500[H]C_{mod}HOT400/30AAmulti
* EI 120 (v_{ew}) S1500[H]C₁₀₀₀₀AAmulti**

- Standard low- and high-density rigid wall construction according to EN 1363-1
- For connection of following duct → see page 52

** Applies to MSD-W damper*

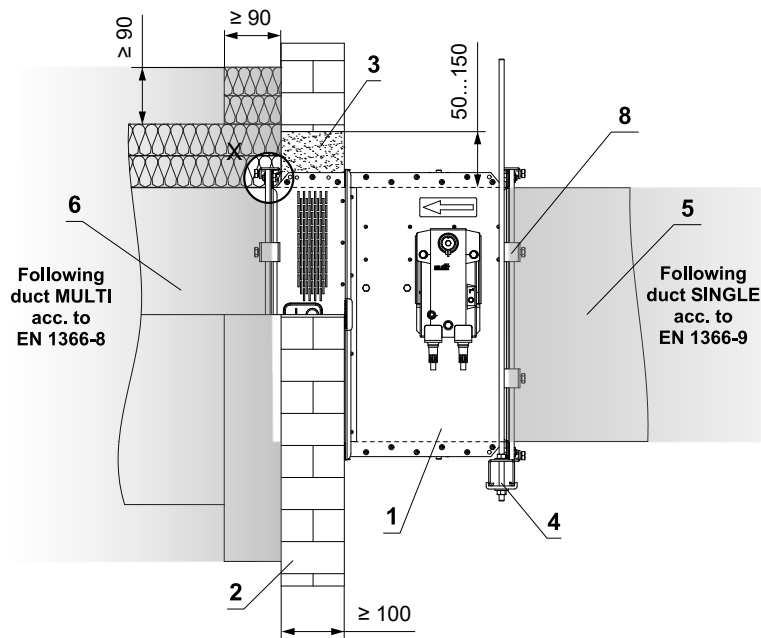
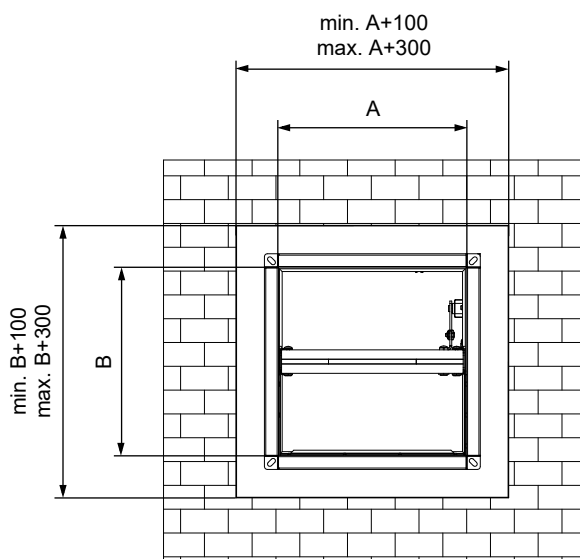
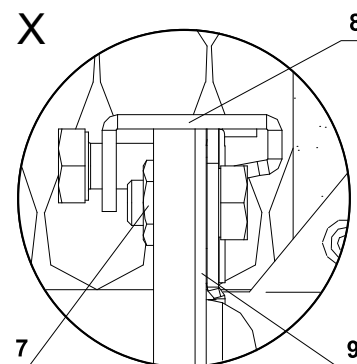
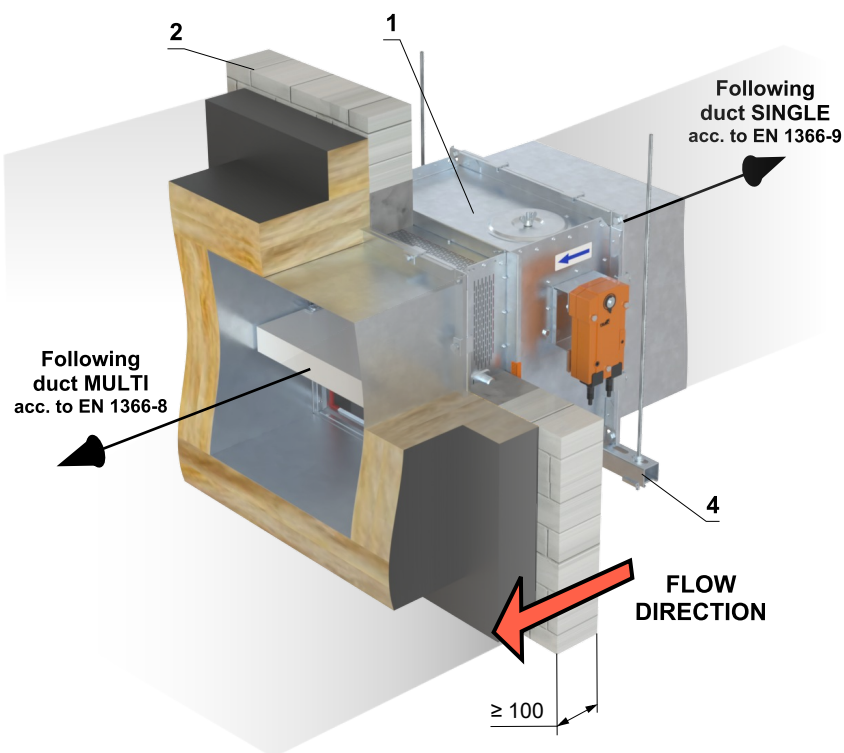

- 1 MSD-W / MSD - design „A“
- 2 Solid wall construction
- 3 Mortar or gypsum
- 4 Suspension system (type according to duct manufacturer instructions) → see page 51
- 5 SINGLE duct made of sheet metal, thickness min. 1 mm, acc. to EN 1366-9
- 6 MULTI duct made of sheet metal acc. to EN 1366-8 → see page 48
- 7 Flange connection at corners - M10 bolt, washers and nut
- 8 M8 C-clamps - maximum spacing of C-clamps 200 mm (type according to duct manufacturer instructions)
- 9 Ceramic selfadhesive sealing tape - around the duct circumference (type according to duct manufacturer instructions)

**In solid wall construction - mortar or gypsum
- damper placement in a multi section**

EI 120 (v_{ew}) S1500[H]C_{mod}HOT400/30AAmulti

- Standard low- and high-density rigid wall construction according to EN 1363-1
- For connection of following duct → see page 52

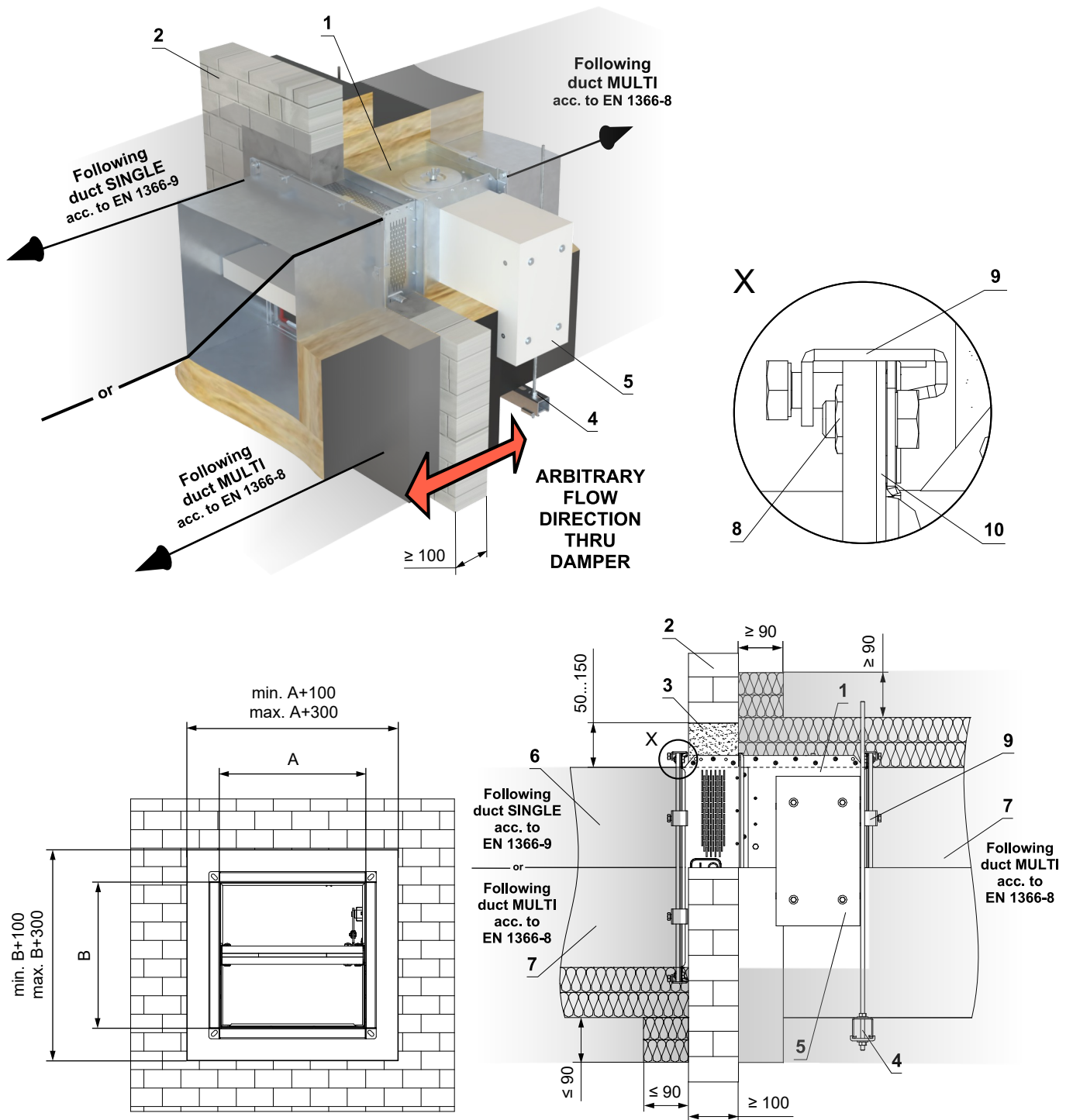

- 1 MSD - design „IB“
- 2 Solid wall construction
- 3 Mortar or gypsum
- 4 Suspension system (type according to duct manufacturer instructions) → see page 51
- 5 Actuator cover - must be removable after installation of the damper
- 6 SINGLE duct made of sheet metal, thickness min. 1 mm, acc. to EN 1366-9
- 7 MULTI duct made of sheet metal acc. to EN 1366-8 → see page 48
- 8 Flange connection at corners - M10 bolt, washers and nut
- 9 M8 C-clamps - maximum spacing of C-clamps 200 mm (type according to duct manufacturer instructions)
- 10 Ceramic selfadhesive sealing tape - around the duct circumference (type according to duct manufacturer instructions)

**In solid wall construction - Ablative Coated Batt
- damper placement in a single section**

EI 120 (v_{ew}) S1500[H]C_{mod}HOT400/30AAmulti
* EI 120 (v_{ew}) S1500[H]C₁₀₀₀₀AAmulti

- Standard low- and high-density rigid wall construction according to EN 1363-1
- For connection of following duct → see page 52

* Applies to MSD-W damper

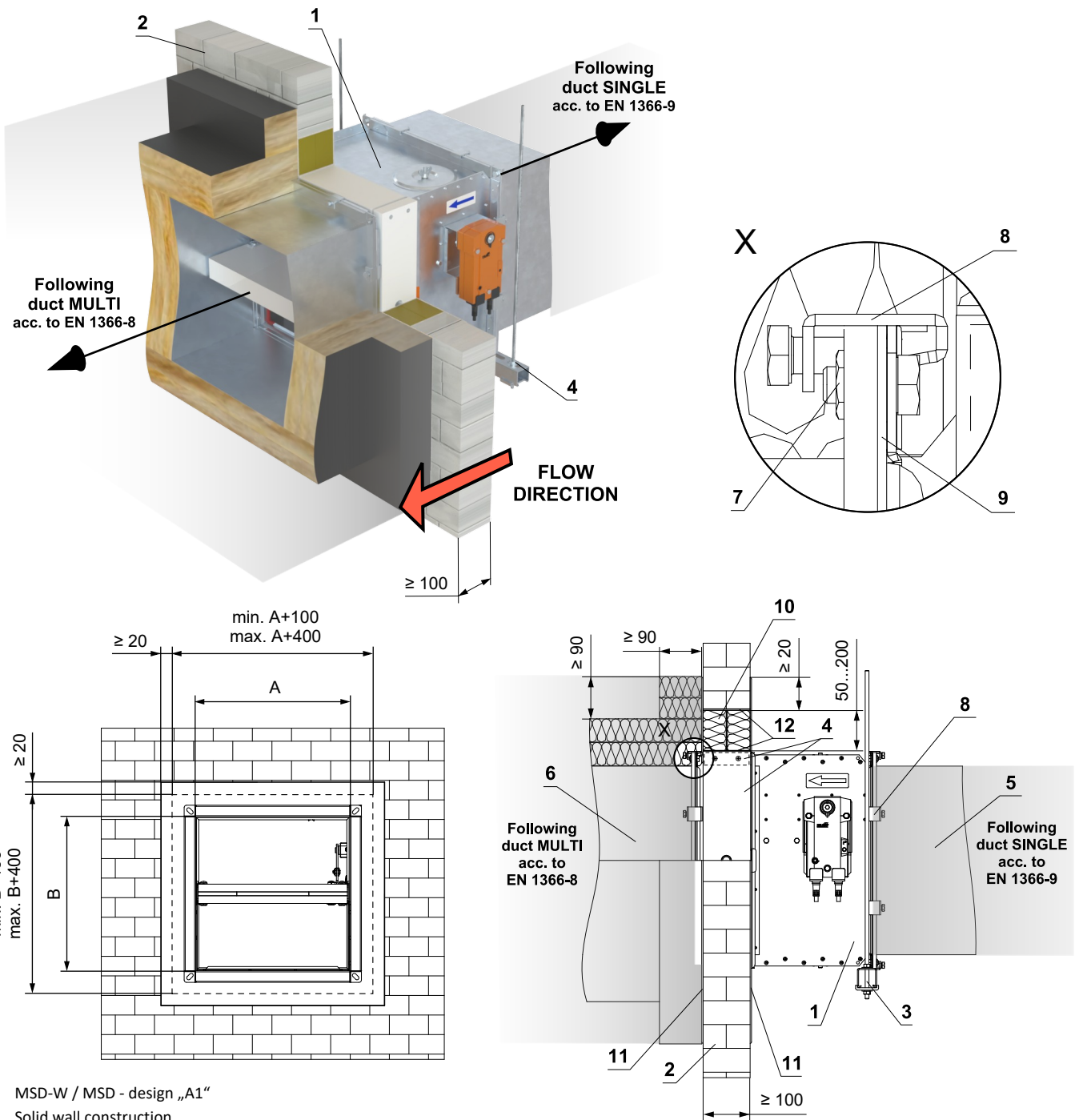

- 1 MSD-W / MSD - design „A1“
- 2 Solid wall construction
- 3 Suspension system (type according to duct manufacturer instructions) → see page 51
- 4 Protective cladding board - min. th. 30 mm, min. density 750 kg/m³ (e.g. PROMATECT-MST) → see page 59
- 5 SINGLE duct made of sheet metal, thickness min. 1 mm, acc. to EN 1366-9
- 6 MULTI duct made of sheet metal acc. to EN 1366-8 → see page 48
- 7 Flange connection at corners - M10 bolt, washers and nut
- 8 M8 C-clamps - maximum spacing of C-clamps 200 mm (type according to duct manufacturer instructions)
- 9 Ceramic selfadhesive sealing tape - around the duct circumference (type according to duct manufacturer instructions)
- Ablative Coated Batt System HILTI*
- 10 Mineral wool board - min. density 140 kg/m³ (HILTI CFS-CT B 1S 140/50...)
- 11 Fire stop coating - th. 1 mm (HILTI CFS-CT...) - coating is overcoated on the support construction and on the damper casing/duct.
- 12 Fire-resistant mastic - (HILTI CFS-S ACR...) fill the gap from both sides of the fire separation construction and around the perimeter of penetration and damper casing.

* HILTI system can be replaced by a similar system with the same or higher thickness, density, fire reaction class, tested according to EN 1366-3.

In solid wall construction - Ablative Coated Batt - damper placement in a multi section

EI 120 (v_{ew}) S1500[H]C_{mod}HOT400/30AAmulti

- Standard low- and high-density rigid wall construction according to EN 1363-1
- For connection of following duct → see page 52

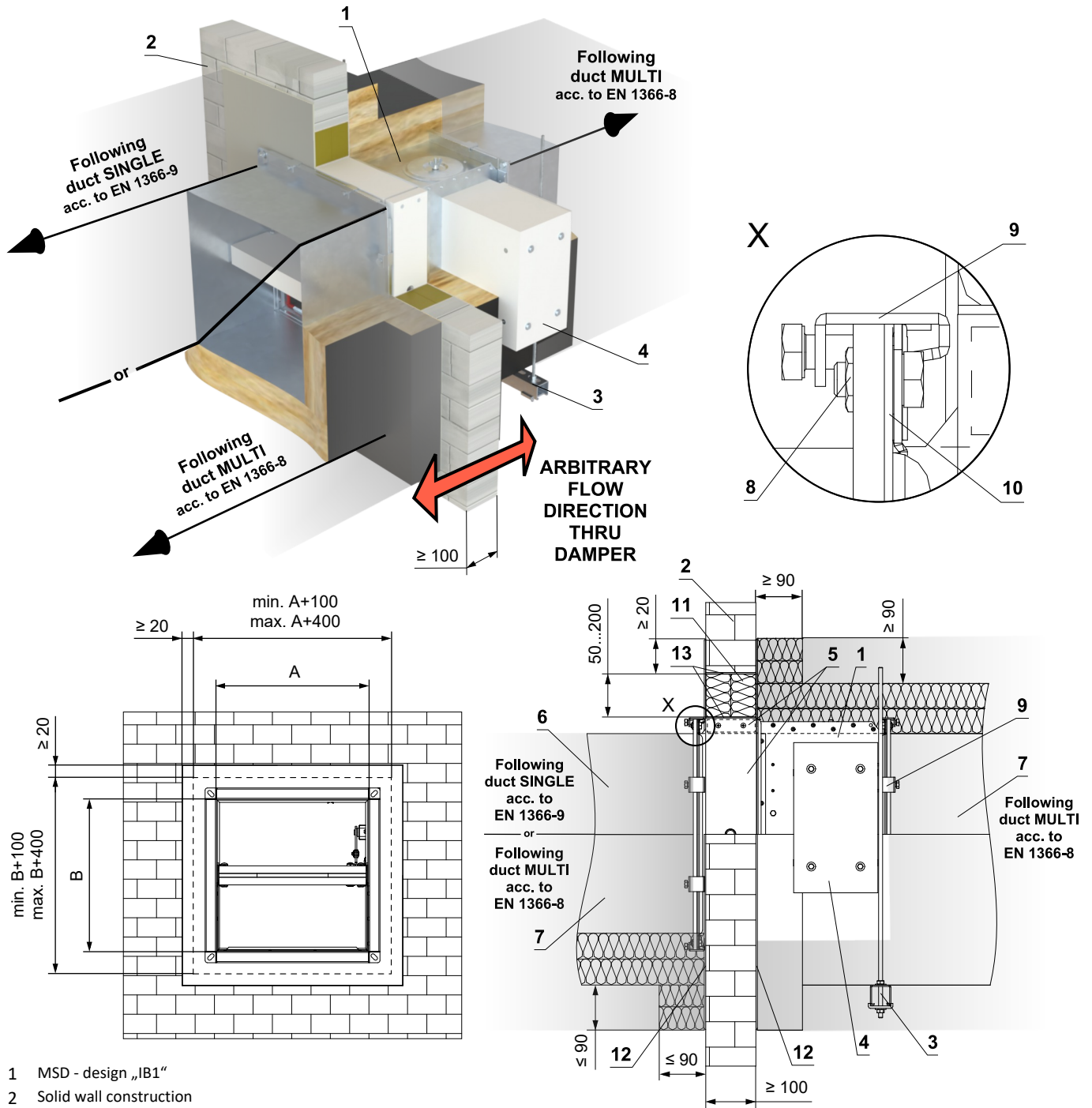

- 1 MSD - design „IB1“
- 2 Solid wall construction
- 3 Suspension system (type according to duct manufacturer instructions) → see page 51
- 4 Actuator cover - must be removable after installation of the damper
- 5 Protective cladding board - min. th. 30 mm, min. density 750 kg/m³ (e.g. PROMATECT-MST) → see page 59
- 6 SINGLE duct made of sheet metal, thickness min. 1 mm, acc. to EN 1366-9
- 7 MULTI duct made of sheet metal acc. to EN 1366-8 → see page 48
- 8 Flange connection at corners - M10 bolt, washers and nut
- 9 M8 C-clamps - maximum spacing of C-clamps 200 mm (type according to duct manufacturer instructions)
- 10 Ceramic selfadhesive sealing tape - around the duct circumference (type according to duct manufacturer instructions) Ablative Coated Batt System HILTI*
- 11 Mineral wool board - min. density 140 kg/m³ (HILTI CFS-CT B 1S 140/50...)
- 12 Fire stop coating - th. 1 mm (HILTI CFS-CT...) - coating is overcoated on the support construction and on the damper casing/duct.
- 13 Fire-resistant mastic - (HILTI CFS-S ACR...) fill the gap from both sides of the fire separation construction and around the perimeter of penetration and damper casing.

* HILTI system can be replaced by a similar system with the same or higher thickness, density, fire reaction class, tested according to EN 1366-3.

In gypsum wall construction

**In gypsum wall construction min. EI 90 - mortar or gypsum
- damper placement in a single section**

EI 120 (v_{ew}) S1500[H]C₁₀₀₀₀AAmulti

- Standard flexible wall construction min. EI 90 according to EN 1363-1.
- For connection of following duct → see page 52
- The installation opening is lined with a UW/CW profile.

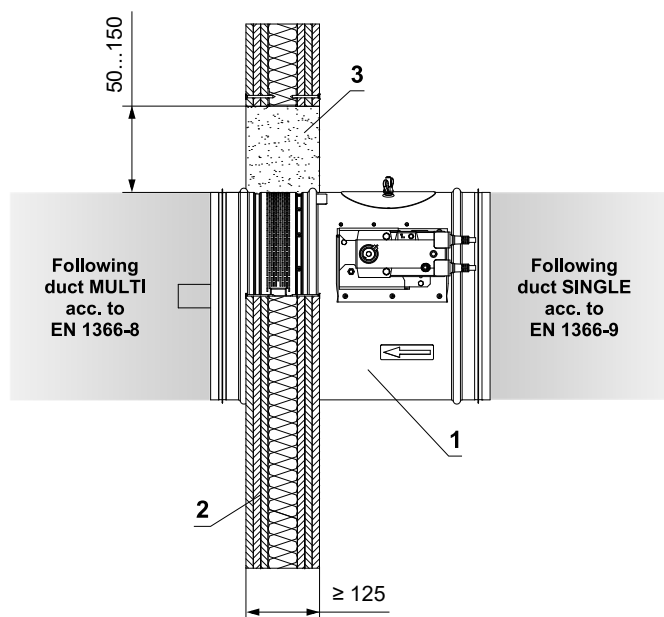
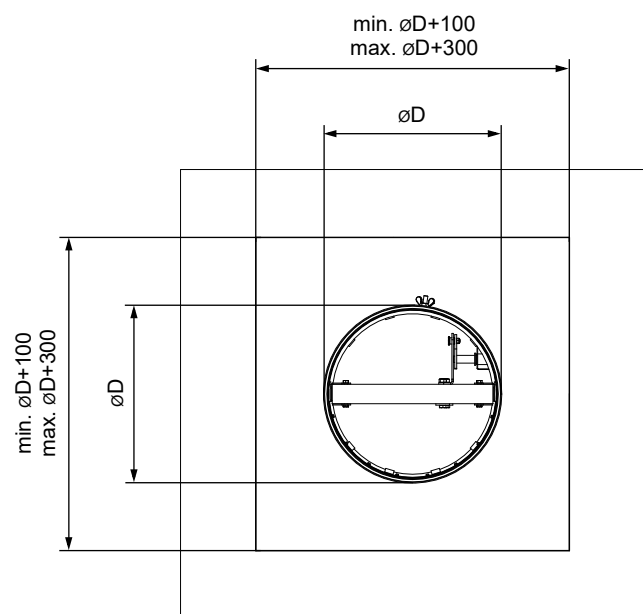
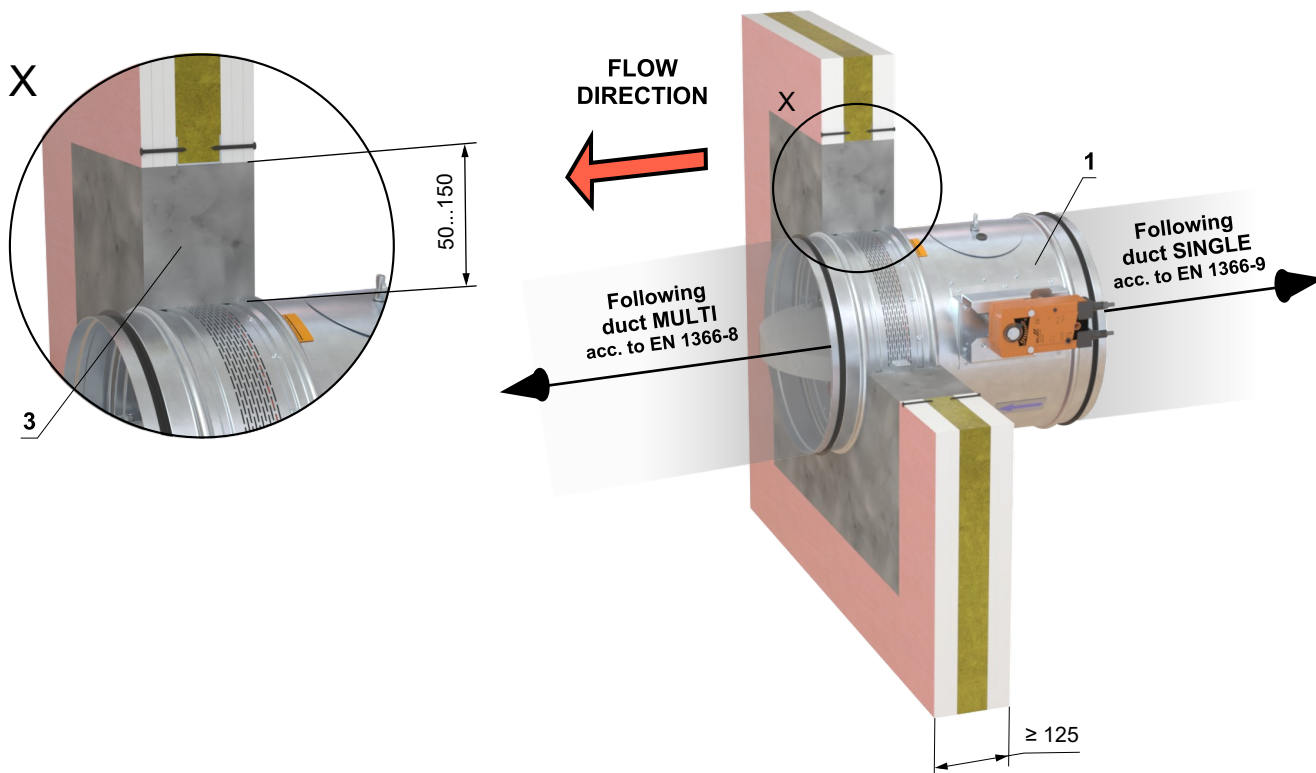

- 1 MSD-W / MSD - design „A“
- 2 Gypsum wall construction
- 3 Mortar or gypsum

**In gypsum wall construction min. EI 90 - mortar or gypsum
- damper placement in a single section**

**EI 120 (v_{ew}) S1500[H]C_{mod}HOT400/30AAmulti
* EI 120 (v_{ew}) S1500[H]C₁₀₀₀₀AAmulti**

** Applies to MSD-W damper*

- Standard flexible wall construction min. EI 90 according to EN 1363-1.
- For connection of following duct → see page 52
- The installation opening is lined with a UW/CW profile.

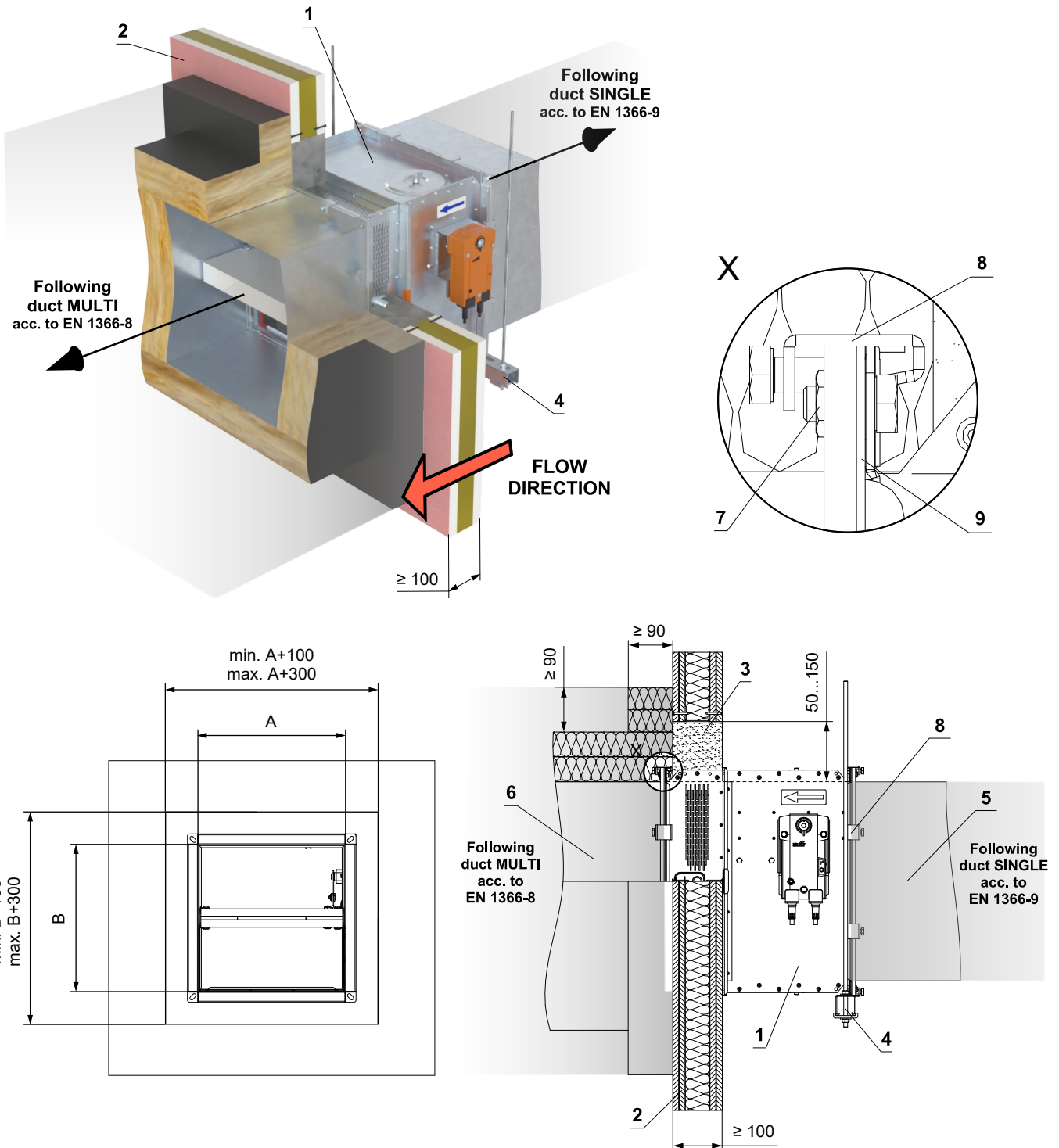

- 1 MSD-W / MSD - design „A“
- 2 Gypsum wall construction
- 3 Mortar or gypsum
- 4 Suspension system (type according to duct manufacturer instructions) → see page 51
- 5 SINGLE duct made of sheet metal, thickness min. 1 mm, acc. to EN 1366-9
- 6 MULTI duct made of sheet metal acc. to EN 1366-8 → see page 48
- 7 Flange connection at corners - M10 bolt, washers and nut
- 8 M8 C-clamps - maximum spacing of C-clamps 200 mm (type according to duct manufacturer instructions)
- 9 Ceramic selfadhesive sealing tape - around the duct circumference (type according to duct manufacturer instructions)

**In gypsum wall construction min. EI 90 - mortar or gypsum
- damper placement in a multi section**

EI 120 (v_{ew}) S1500[H]C_{mod}HOT400/30AAmulti

- Standard flexible wall construction min. EI 90 according to EN 1363-1.
- For connection of following duct → see page 52
- The installation opening is lined with a UW/CW profile.

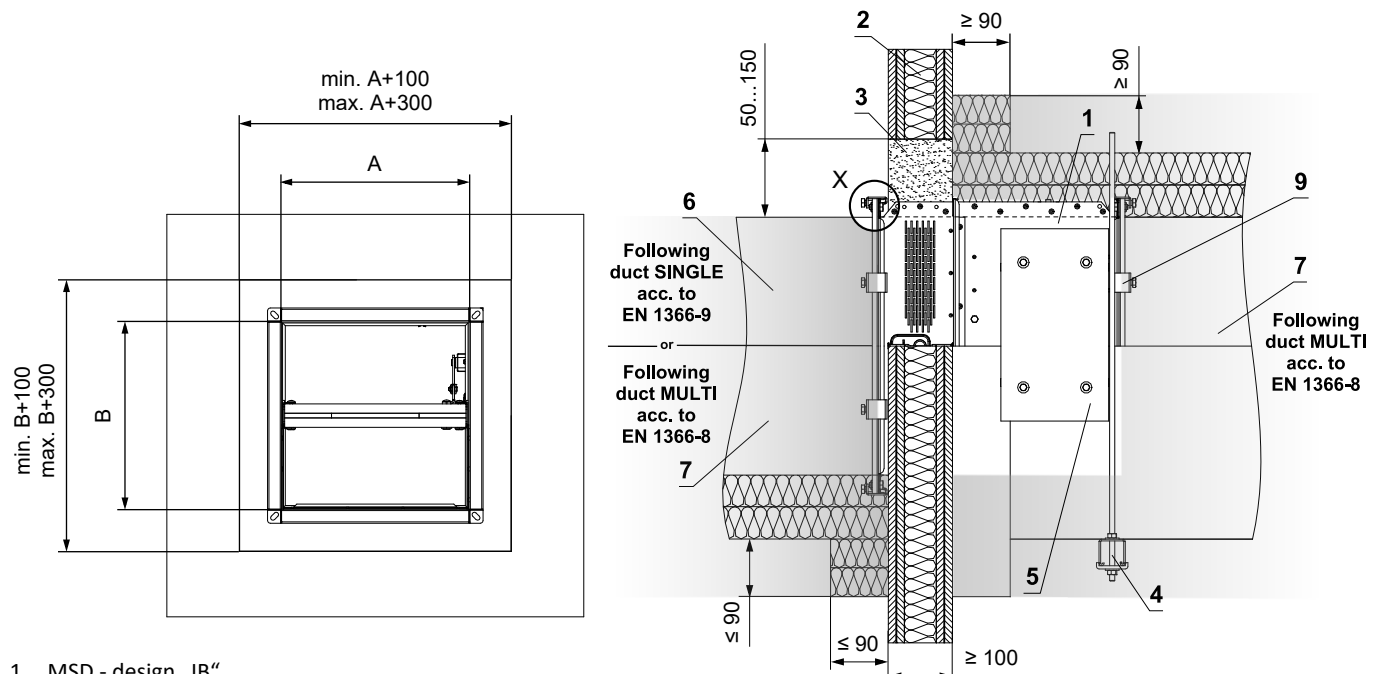
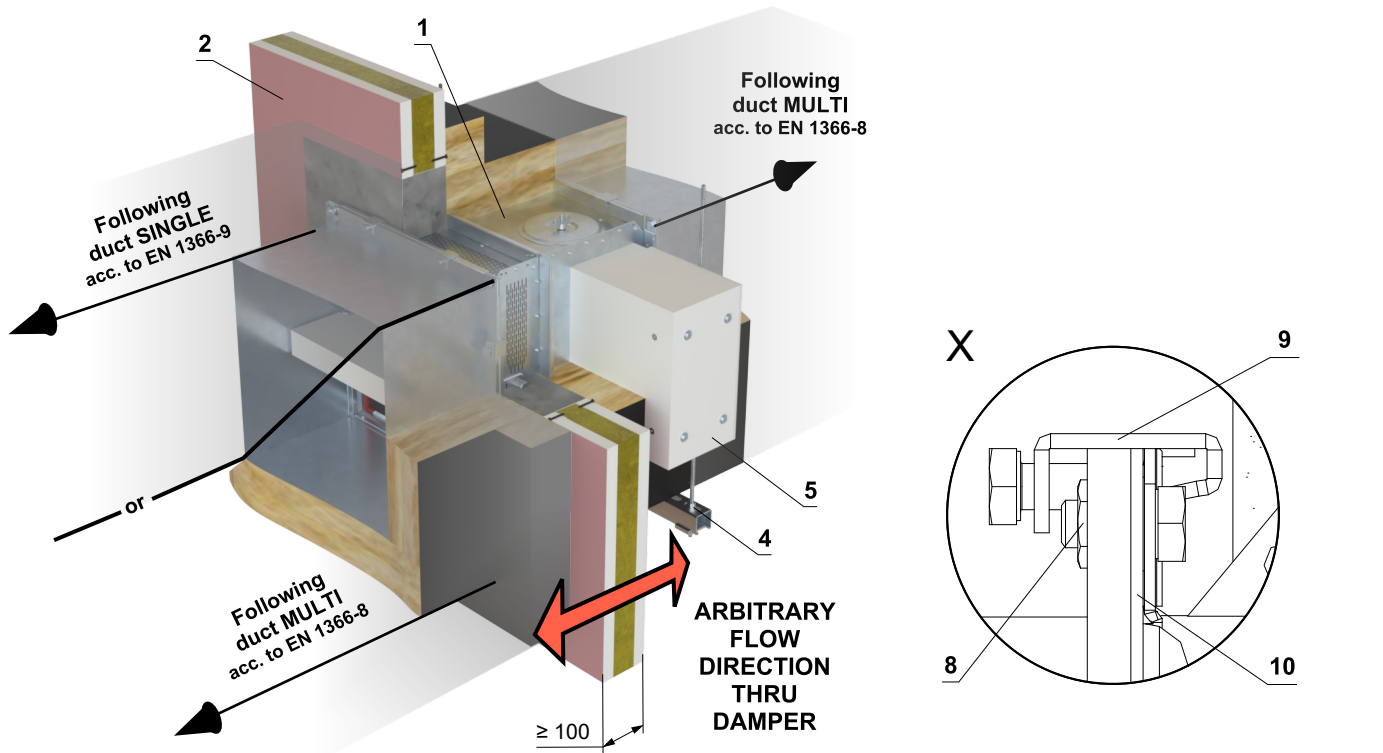

- 1 MSD - design „IB“
- 2 Gypsum wall construction
- 3 Mortar or gypsum
- 4 Suspension system (type according to duct manufacturer instructions) → see page 51
- 5 Actuator cover - must be removable after installation of the damper
- 6 SINGLE duct made of sheet metal, thickness min. 1 mm, acc. to EN 1366-9
- 7 MULTI duct made of sheet metal acc. to EN 1366-8 → see page 48
- 8 Flange connection at corners - M10 bolt, washers and nut
- 9 M8 C-clamps - maximum spacing of C-clamps 200 mm (type according to duct manufacturer instructions)
- 10 Ceramic selfadhesive sealing tape - around the duct circumference (type according to duct manufacturer instructions)

In gypsum wall construction min. EI 90 - Ablative Coated Batt - damper placement in a single section

EI 120 (v_{ew}) S1500[H]C_{mod}HOT400/30AAmulti
*** EI 120 (v_{ew}) S1500[H]C₁₀₀₀₀AAmulti**

** Applies to MSD-W damper*

- Standard flexible wall construction min. EI 90 according to EN 1363-1.
- For connection of following duct → see page 52
- The installation opening is lined with a UW/CW profile.

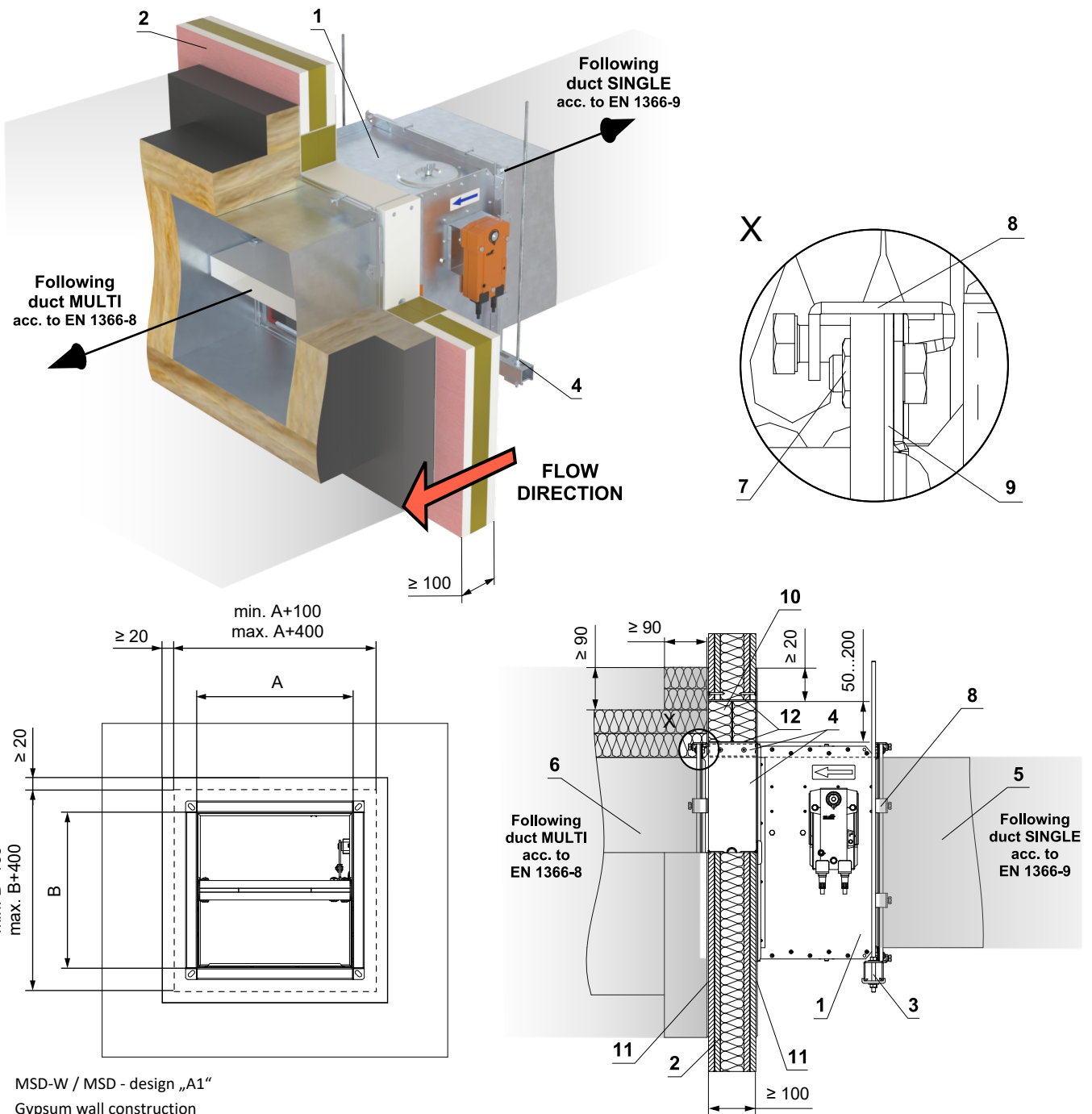

- 1 MSD-W / MSD - design „A1“
- 2 Gypsum wall construction
- 3 Suspension system (type according to duct manufacturer instructions) → see page 51
- 4 Protective cladding board - min. th. 30 mm, min. density 750 kg/m³ (e.g. PROMATECT-MST) → see page 59
- 5 SINGLE duct made of sheet metal, thickness min. 1 mm, acc. to EN 1366-9
- 6 MULTI duct made of sheet metal acc. to EN 1366-8 → see page 48
- 7 Flange connection at corners - M10 bolt, washers and nut
- 8 M8 C-clamps - maximum spacing of C-clamps 200 mm (type according to duct manufacturer instructions)
- 9 Ceramic selfadhesive sealing tape - around the duct circumference (type according to duct manufacturer instructions)
- Ablative Coated Batt System HILTI*
- 10 Mineral wool board - min. density 140 kg/m³ (HILTI CFS-CT B 1S 140/50...)
- 11 Fire stop coating - th. 1 mm (HILTI CFS-CT...) - coating is overcoated on the support construction and on the damper casing/duct.
- 12 Fire-resistant mastic - (HILTI CFS-S ACR...) fill the gap from both sides of the fire separation construction and around the perimeter of penetration and damper casing.

* HILTI system can be replaced by a similar system with the same or higher thickness, density, fire reaction class, tested according to EN 1366-3.

In gypsum wall construction min. EI 90 - Ablative Coated Batt - damper placement in a multi section

EI 120 (v_{ew}) S1500[H]C_{mod}HOT400/30AAmulti

- Standard flexible wall construction min. EI 90 according to EN 1363-1.
- For connection of following duct → see page 52
- The installation opening is lined with a UW/CW profile.

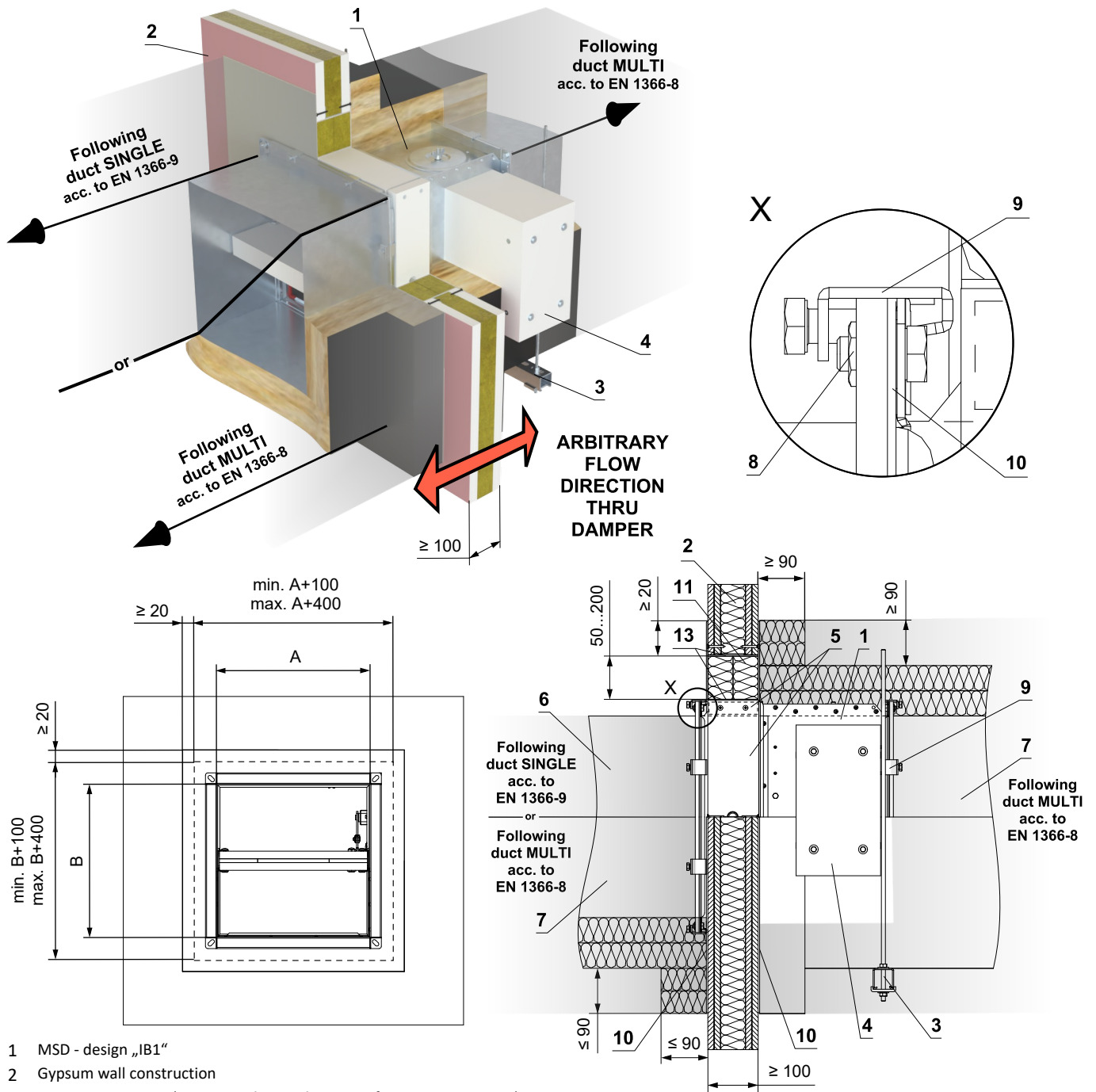

- 1 MSD - design „IB1“
- 2 Gypsum wall construction
- 3 Suspension system (type according to duct manufacturer instructions) → see page 51
- 4 Actuator cover - must be removable after installation of the damper
- 5 Protective cladding board - min. th. 30 mm, min. density 750 kg/m³ (e.g. PROMATECT-MST) → see page 59
- 6 SINGLE duct made of sheet metal, thickness min. 1 mm, acc. to EN 1366-9
- 7 MULTI duct made of sheet metal acc. to EN 1366-8 → see page 48
- 8 Flange connection at corners - M10 bolt, washers and nut
- 9 M8 C-clamps - maximum spacing of C-clamps 200 mm (type according to duct manufacturer instructions)
- 10 Ceramic selfadhesive sealing tape - around the duct circumference (type according to duct manufacturer instructions)
- 11 Mineral wool board - min. density 140 kg/m³ (HILTI CFS-CT B 1S 140/50...)
- 12 Fire stop coating - th. 1 mm (HILTI CFS-CT...) - coating is overcoated on the support construction and on the damper casing/duct.
- 13 Fire-resistant mastic - (HILTI CFS-S ACR...) fill the gap from both sides of the fire separation construction and around the perimeter of penetration and damper casing.

* HILTI system can be replaced by a similar system with the same or higher thickness, density, fire reaction class, tested according to EN 1366-3.

In solid ceiling construction

In solid ceiling construction - mortar or gypsum - damper placement in a single section

EI 120 (h_{ow}) S1500[H]C₁₀₀₀₀AAmulti

- Standard low- and high-density rigid floor construction according to EN 1366-2
- For connection of following duct → see page 52
- The damper can be installed from both sides of the construction, i.e. from the top or the bottom side of the ceiling

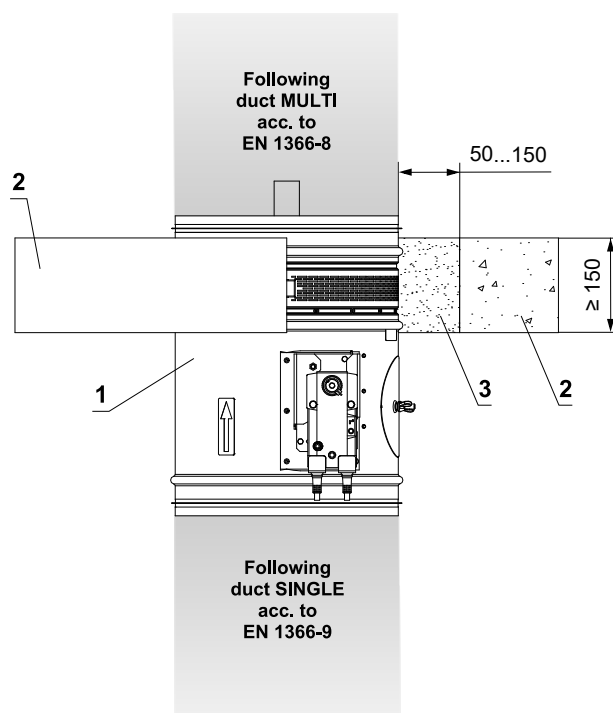
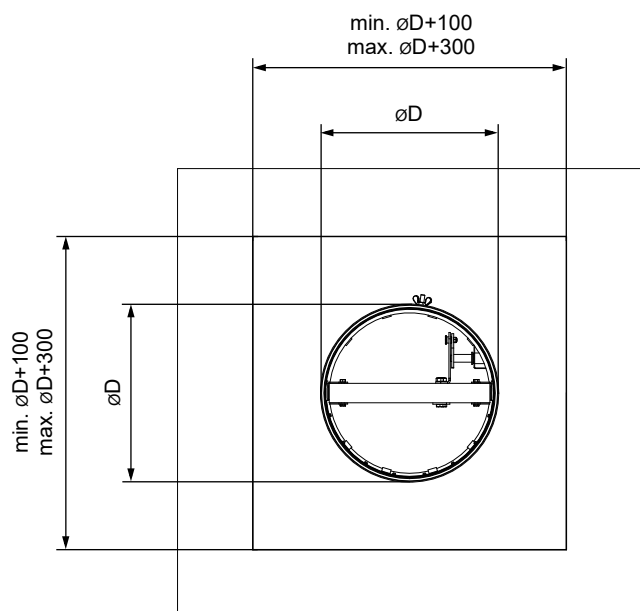
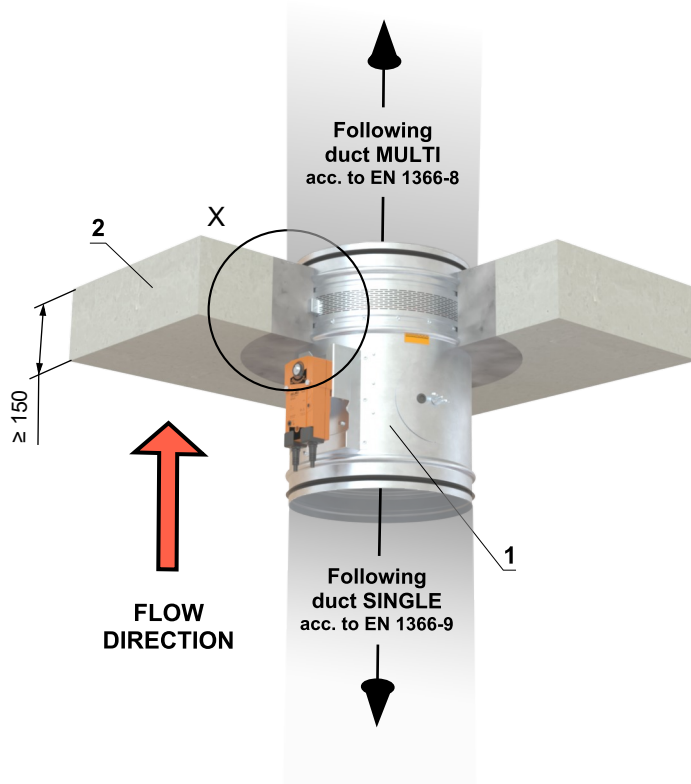
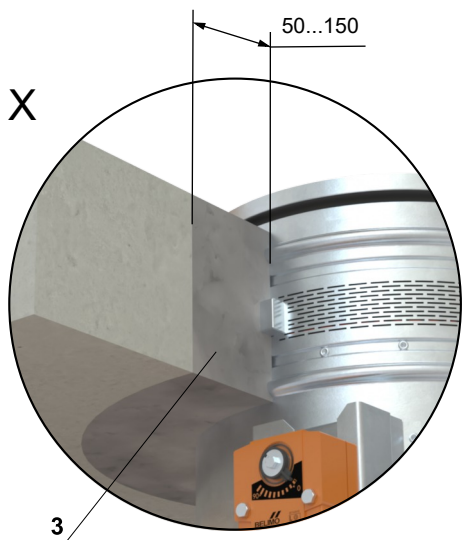

- 1 MSD-W / MSD - design „A“
- 2 Solid ceiling construction
- 3 Mortar or gypsum

**In solid ceiling construction - mortar or gypsum
- damper placement in a single section**

- Standard low- and high-density rigid floor construction according to EN 1366-2
- For connection of following duct → see page 52
- The damper can be installed from both sides of the construction, i.e. from the top or the bottom side of the ceiling

EI 120 (h_{ow}) S1500[H]C_{mod}HOT400/30AAmulti
*** EI 120 (h_{ow}) S1500[H]C₁₀₀₀₀AAmulti**

** Applies to MSD-W damper*

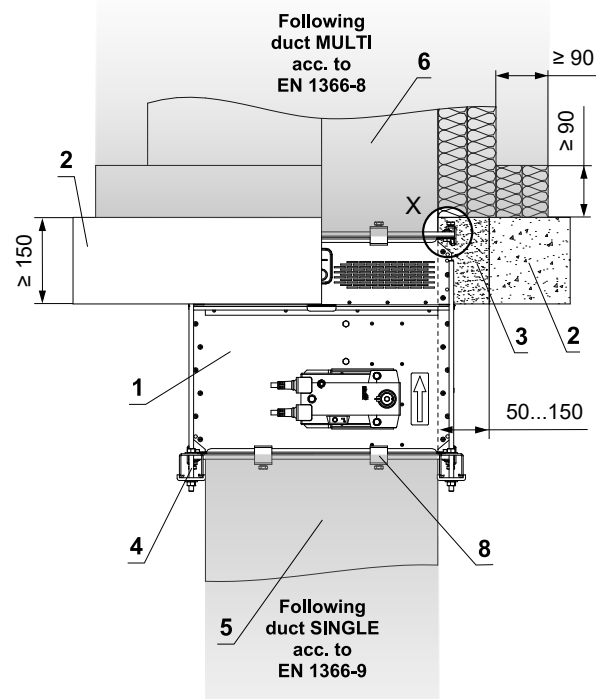
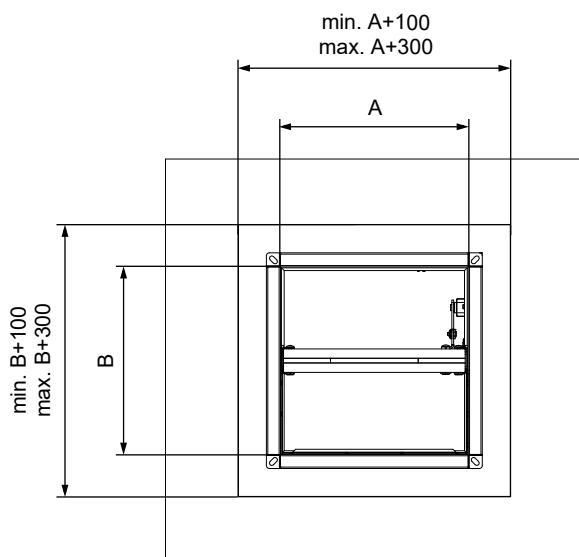
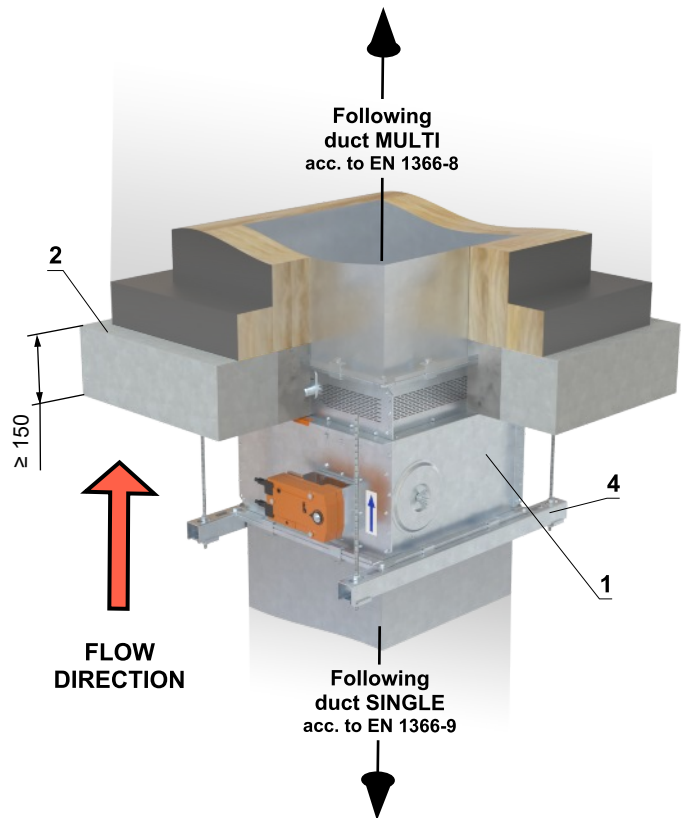
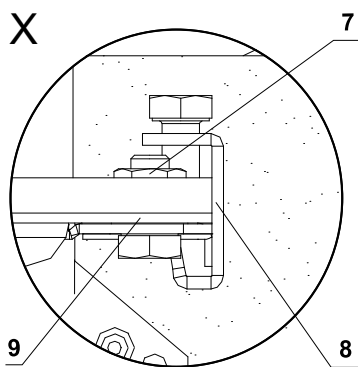

- 1 MSD-W / MSD - design „A“
- 2 Solid ceiling construction
- 3 Mortar or gypsum
- 4 Suspension system (type according to duct manufacturer instructions) → see page 51
- 5 SINGLE duct made of sheet metal, thickness min. 1 mm, acc. to EN 1366-9
- 6 MULTI duct made of sheet metal acc. to EN 1366-8 → see page 48
- 7 Flange connection at corners - M10 bolt, washers and nut
- 8 M8 C-clamps - maximum spacing of C-clamps 200 mm (type according to duct manufacturer instructions)
- 9 Ceramic selfadhesive sealing tape - around the duct circumference (type according to duct manufacturer instructions)

**In solid ceiling construction - mortar or gypsum
- damper placement in a multi section**

- Standard low- and high-density rigid floor construction according to EN 1366-2
- For connection of following duct → see page 52
- The damper can be installed from both sides of the construction, i.e. from the top or the bottom side of the ceiling

EI 120 (h_{ow}) S1500[H]C_{mod}HOT400/30AAmulti

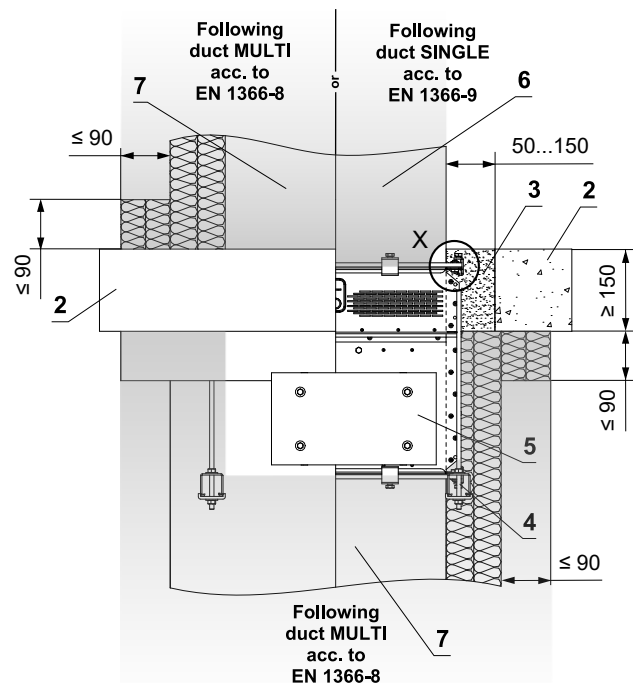
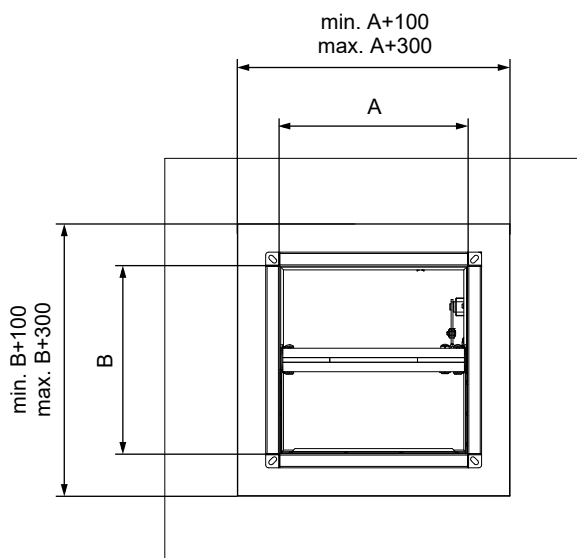
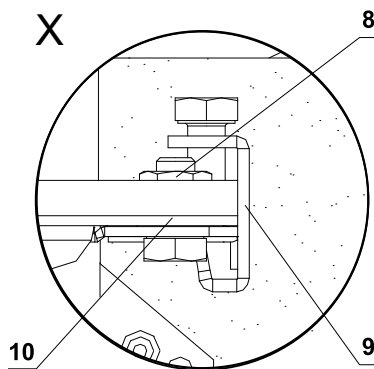
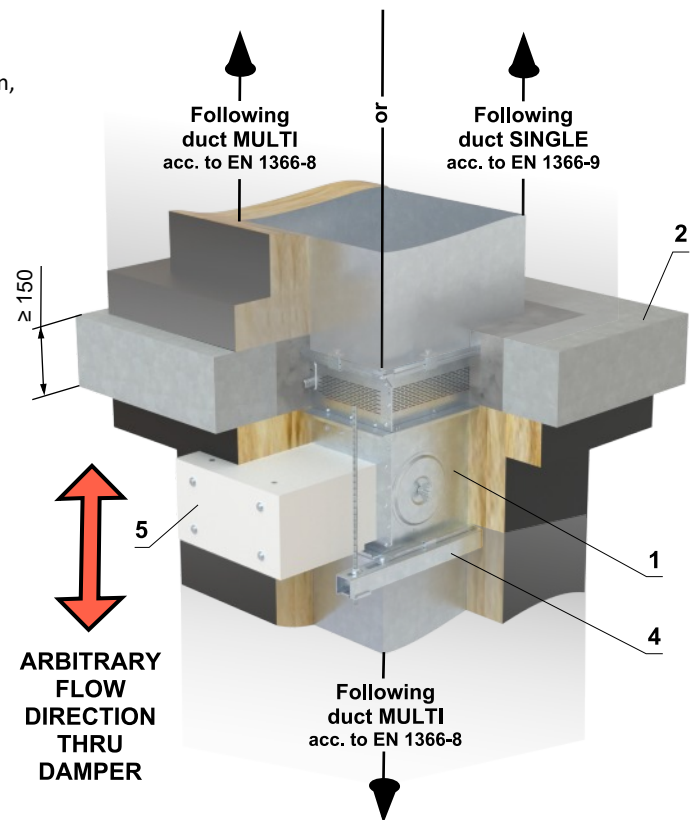

- 1 MSD - design „IB“
- 2 Solid ceiling construction
- 3 Mortar or gypsum
- 4 Suspension system (type according to duct manufacturer instructions) → see page 51
- 5 Actuator cover - must be removable after installation of the damper
- 6 SINGLE duct made of sheet metal, thickness min. 1 mm, acc. to EN 1366-9
- 7 MULTI duct made of sheet metal acc. to EN 1366-8 → see page 48
- 8 Flange connection at corners - M10 bolt, washers and nut
- 9 M8 C-clamps - maximum spacing of C-clamps 200 mm (type according to duct manufacturer instructions)
- 10 Ceramic selfadhesive sealing tape - around the duct circumference (type according to duct manufacturer instructions)

In solid ceiling construction - Ablative Coated Batt - damper placement in a single section

- Standard low- and high-density rigid floor construction according to EN 1366-2
- For connection of following duct → see page 52
- The damper can be installed from both sides of the construction, i.e. from the top or the bottom side of the ceiling

EI 90 (h_{ow}) S1500[H]C_{mod}HOT400/30AAmulti
 E 120 (h_{ow}) S1500[H]C_{mod}HOT400/30AAmulti
 * EI 120 (h_{ow}) S1500[H]C₁₀₀₀₀AAmulti

* Applies to MSD-W damper

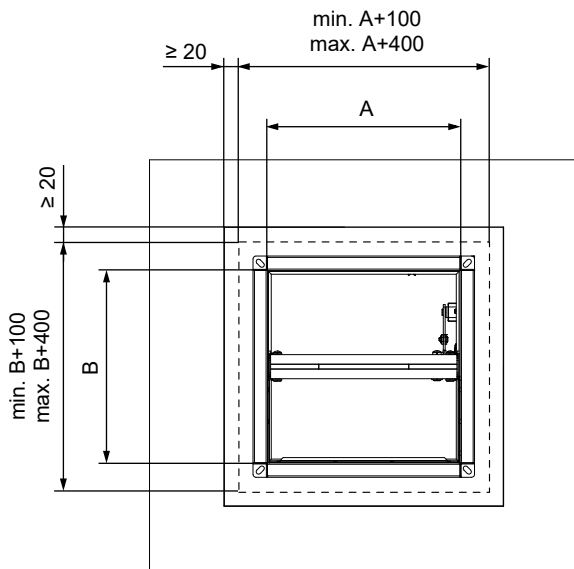
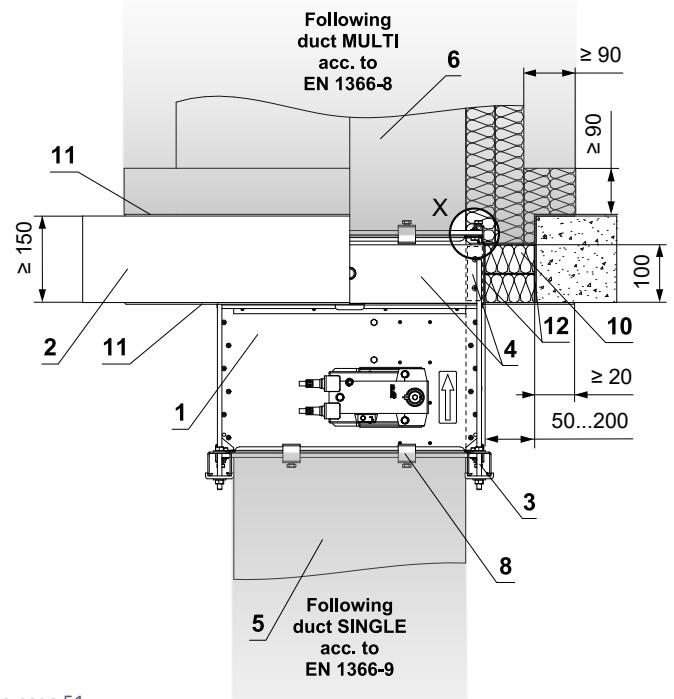
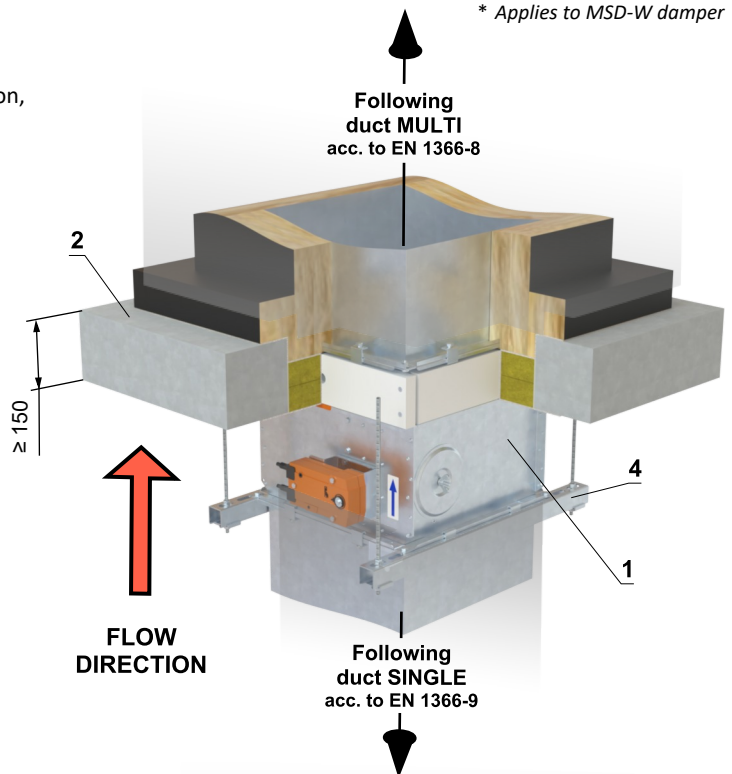
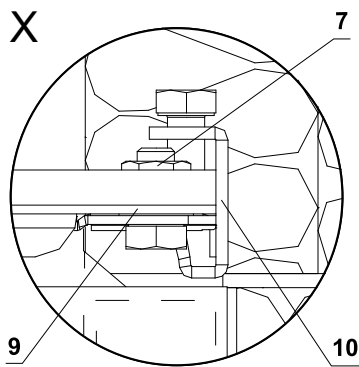

- MSD-W / MSD - design „A1“
- Solid ceiling construction
- Suspension system (type according to duct manufacturer instructions) → see page 51
- Protective cladding board - min. th. 30 mm, min. density 750 kg/m³ (e.g. PROMATECT-MST) → see page 59
- SINGLE duct made of sheet metal, thickness min. 1 mm, acc. to EN 1366-9
- MULTI duct made of sheet metal acc. to EN 1366-8 → see page 48
- Flange connection at corners - M10 bolt, washers and nut
- M8 C-clamps - maximum spacing of C-clamps 200 mm (type according to duct manufacturer instructions)
- Ceramic selfadhesive sealing tape - around the duct circumference (type according to duct manufacturer instructions) Ablative Coated Batt System HILTI*
- Mineral wool board - min. density 140 kg/m³ (HILTI CFS-CT B 1S 140/50...)
- Fire stop coating - th. 1 mm (HILTI CFS-CT...) - coating is overcoated on the support construction and on the damper casing/duct.
- Fire-resistant mastic - (HILTI CFS-S ACR...) fill the gap from both sides of the fire separation construction and around the perimeter of penetration and damper casing.

* HILTI system can be replaced by a similar system with the same or higher thickness, density, fire reaction class, tested according to EN 1366-3.

In solid ceiling construction - Ablative Coated Batt - damper placement in a multi section

- Standard low- and high-density rigid floor construction according to EN 1366-2
- For connection of following duct → see page 52
- The damper can be installed from both sides of the construction, i.e. from the top or the bottom side of the ceiling

EI 90 (h_{ow}) S1500[H]C_{mod}HOT400/30AAmulti
E 120 (h_{ow}) S1500[H]C_{mod}HOT400/30AAmulti

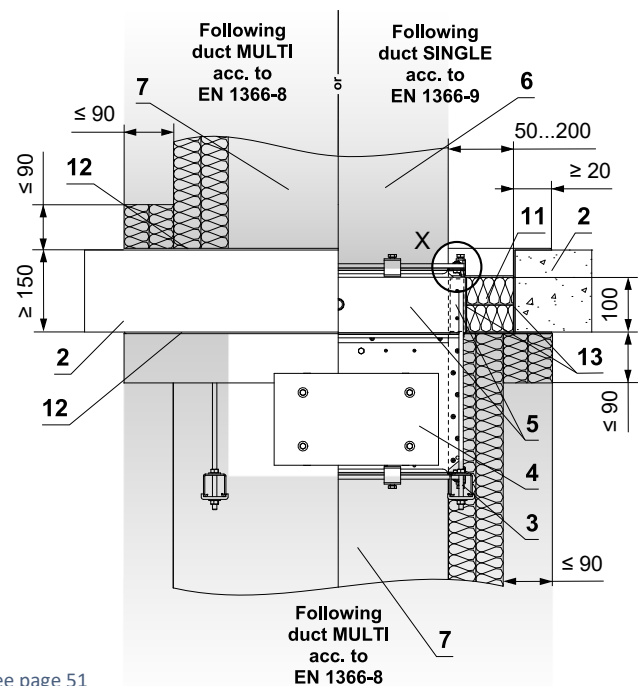
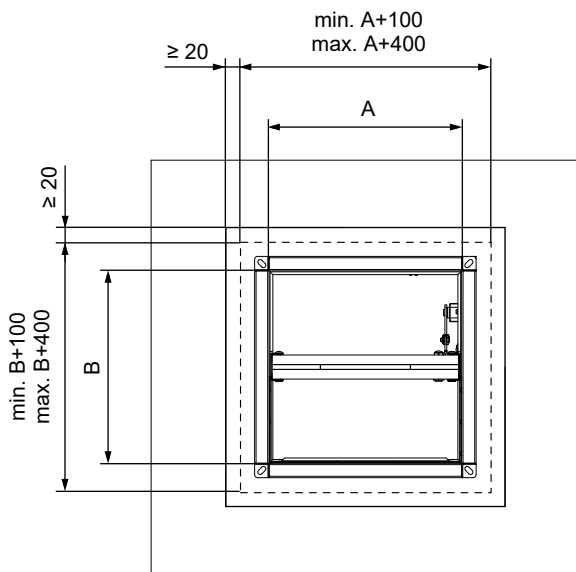
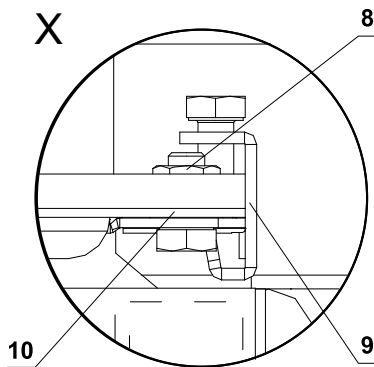
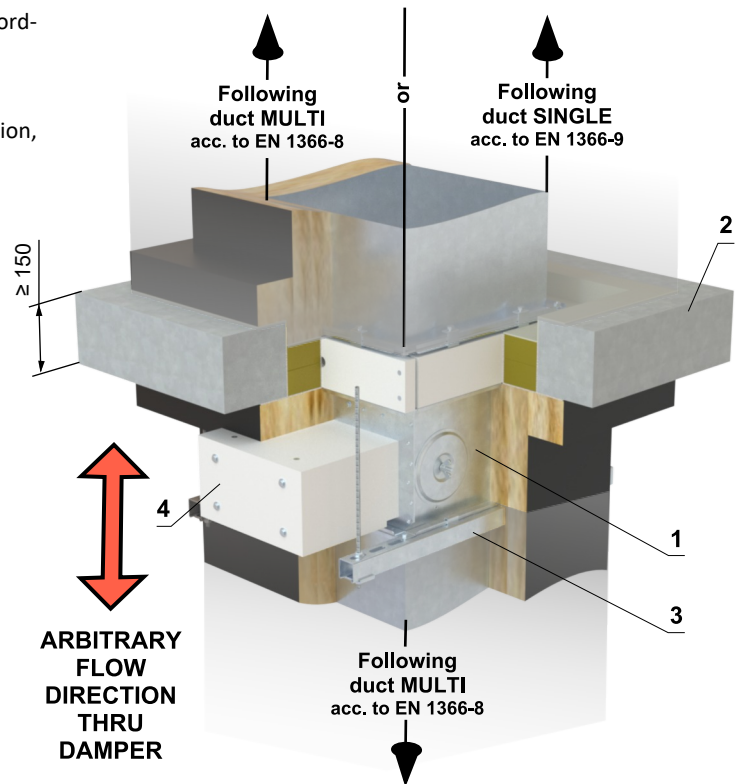

- MSD - design „IB1“
- Solid ceiling construction
- Suspension system (type according to duct manufacturer instructions) → see page 51
- Actuator cover - must be removable after installation of the damper
- Protective cladding board - min. th. 30 mm, min. density 750 kg/m³ (e.g. PROMATECT-MST) → see page 59
- SINGLE duct made of sheet metal, thickness min. 1 mm, acc. to EN 1366-9
- MULTI duct made of sheet metal acc. to EN 1366-8 → see page 48
- Flange connection at corners - M10 bolt, washers and nut
- M8 C-clamps - maximum spacing of C-clamps 200 mm (type according to duct manufacturer instructions)
- Ceramic selfadhesive sealing tape - around the duct circumference (type according to duct manufacturer instructions) Ablative Coated Batt System HILTI*
- Mineral wool board - min. density 140 kg/m³ (HILTI CFS-CT B 1S 140/50...)
- Fire stop coating - th. 1 mm (HILTI CFS-CT...) - coating is overcoated on the support construction and on the damper casing/duct.
- Fire-resistant mastic - (HILTI CFS-S ACR...) fill the gap from both sides of the fire separation construction and around the perimeter of penetration and damper casing.

* HILTI system can be replaced by a similar system with the same or higher thickness, density, fire reaction class, tested according to EN 1366-3.

Installation damper into/onto smoke extraction ducts

Installation of the damper into/onto horizontal or vertical steel smoke extraction duct insulated with mineral wool - damper placement in a multi section

EI 120 (h_{od}) S1500[H]C_{mod}HOT400/30AAmulti
EI 120 (v_{ed}) S1500[H]C_{mod}HOT400/30AAmulti

- The dampers may be installed onto or into smoke extraction ducts listed below:
 - **Flameshield Fireduct (manufacturer Kent Ductwork Ltd.)**
The duct is made of 1.2 mm thick galvanized steel sheet and insulated with 1 layer of 90 mm thick stone wool Rockwool FirePro DuctRock Slab (manufacturer ROCKWOOL Ltd.). The stone wool is finished with a black aluminium foil on the outer side.
 - **FPL08 (manufacturer Fire Protection Ltd)**
The duct is made of galvanized steel sheet. The thickness of the duct depends on its dimensions. The surface of the duct is coated with fire protection spray Flamebar BW18 (manufacturer Firespray International Ltd). The duct is insulated with two layers of stone wool. The first layer is made of ROCKWOOL FPL 110 SLAB, thickness 50 mm, and the second layer with aluminium foil is made of ROCKWOOL FPL 110 FOIL FACED SLAB, thickness 50 mm (manufacturer ROCKWOOL Ltd.).
- The dampers may be installed onto or into other smoke extraction ducts than that specified above with the following limitations:
 - The duct shall be tested according to EN 1366-9 or EN 1366-8 depending on the intended use.
 - The duct shall be made of material of the same or greater density and of the same or greater thickness as the ducts listed above.
 - Changing surface protection materials is not permitted.
 - Changing the paint surface finish is not permitted.
- Support, drop rods, anchors etc. must be used in accordance with a duct manufacturer instructions.
- The connected duct shall be suspended in such a way that the transfer of all loads from the duct to the damper is completely excluded.
- The damper may be installed in position according picture below

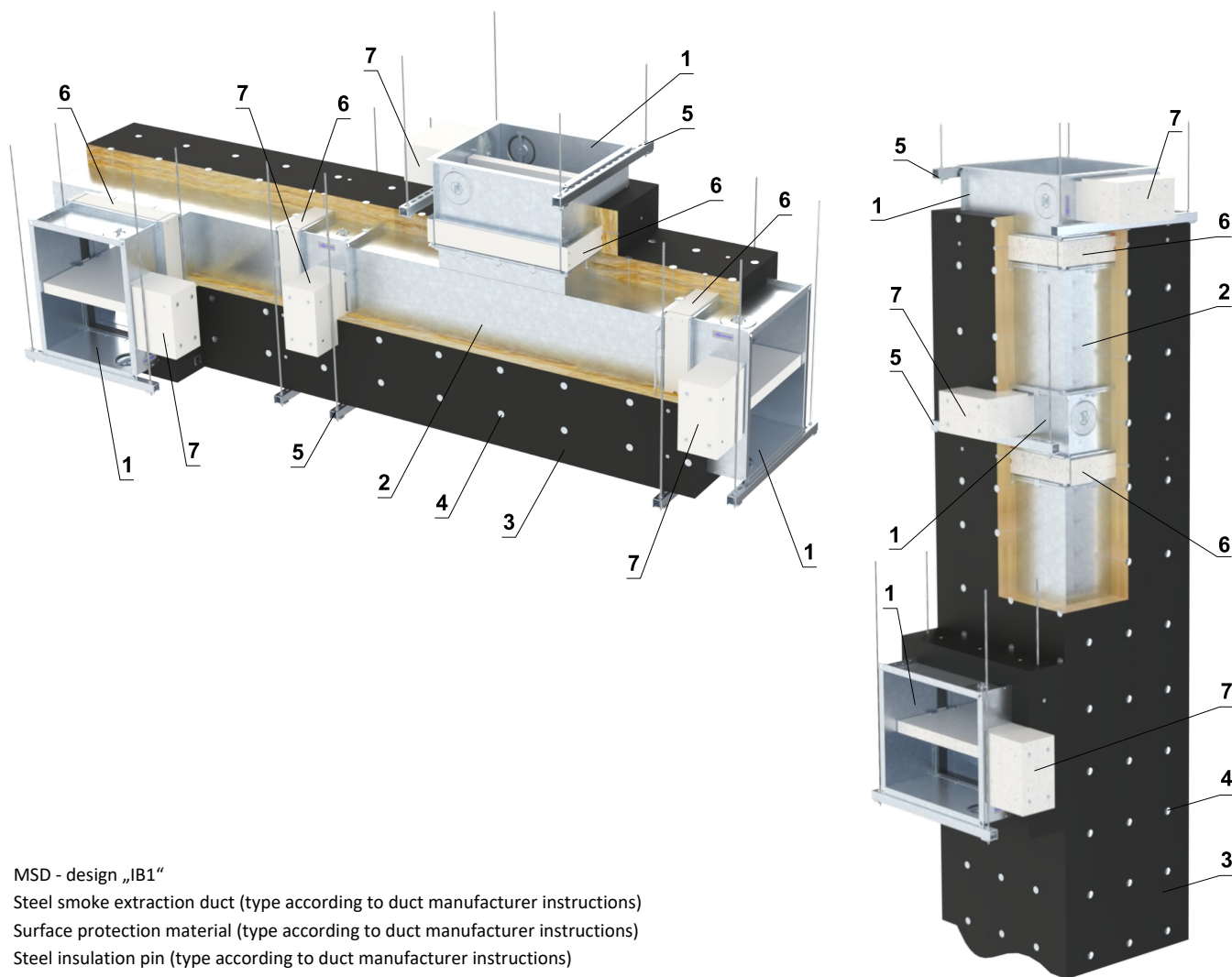

- 1 MSD - design „IB1“
- 2 Steel smoke extraction duct (type according to duct manufacturer instructions)
- 3 Surface protection material (type according to duct manufacturer instructions)
- 4 Steel insulation pin (type according to duct manufacturer instructions)
- 5 Suspension system (type according to duct manufacturer instructions)
- 6 Protective cladding board - min. th. 30 mm, min. density 750 kg/m³ (e.g. PROMATECT-MST) → see page 59
- 7 Actuator cover - must be removable after installation of the damper

(Continued on next page)

continuation of installation damper into/onto horizontal or vertical steel smoke extraction duct insulated with mineral wool

- The damper is connected to the smoke extraction duct by the damper flange as follow:
 - M10 bolts, washers and nuts are used at the corners of the flange
 - C-clamps with M8 bolts with a maximum spacing of 200 mm are used around the circumference
 - Ceramic selfadhesive sealing tape is inserted between flanges
- The duct insulation shall extend at least 230 mm onto the damper body and shall be fixed to the damper at the location of the equalizing strips using screws with a diameter of 5 mm and M5 washers (DIN 125A) at max. spacings of 200 mm; at the sheet metal part, it shall be fixed using steel welding pins (type according to the duct manufacturer's instructions).

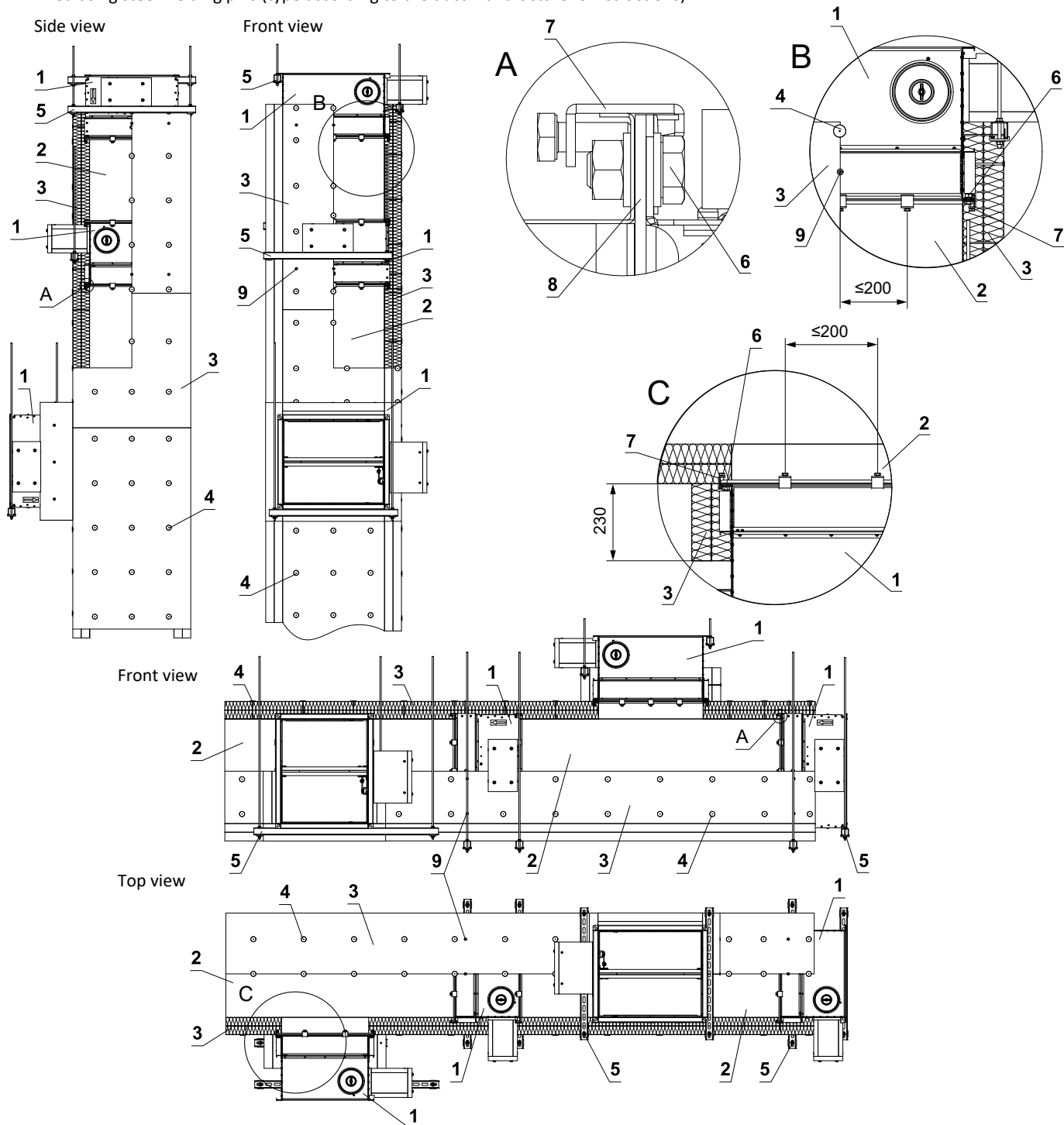

- | | |
|---|--|
| <ul style="list-style-type: none"> 1 MSD - design „IB1“ 2 Steel smoke extraction duct (type according to duct manufacturer instructions) 3 Surface protection material (type according to duct manufacturer instructions) 4 Steel insulation pin (type according to duct manufacturer instructions) 5 Suspension system (type according to duct manufacturer instructions) 6 Flange connection at corners - M10 bolt, washers and nut | <ul style="list-style-type: none"> 7 M8 C-clamps - maximum spacing of C-clamps 200 mm (type according to duct manufacturer instructions) 8 Ceramic selfadhesive sealing tape - around the duct circumference (type according to duct manufacturer instructions) 9 Insulation connection to the damper body - washer M5 (DIN 125A), screw 5xL mm (screw length = insulation thickness + 20 mm) |
|---|--|

V. SUSPENSION SYSTEMS

Mounting to the ceiling wall

- The dampers must be suspended using threaded rods and mounting profiles. Their dimensioning depend on the weight of the damper.
- The dampers and the duct must be suspended separately.
- Following air-conditioning duct must be suspended or supported so that all load transfer from the following duct to the damper flanges is absolutely excluded. Adjacent duct must be suspended or supported, as required by the duct suppliers.
- Threaded rods longer than 1,5 m must be protected by fire insulation.

Examples of anchoring to the ceiling construction Follow the instructions of fixing specialist or installation company

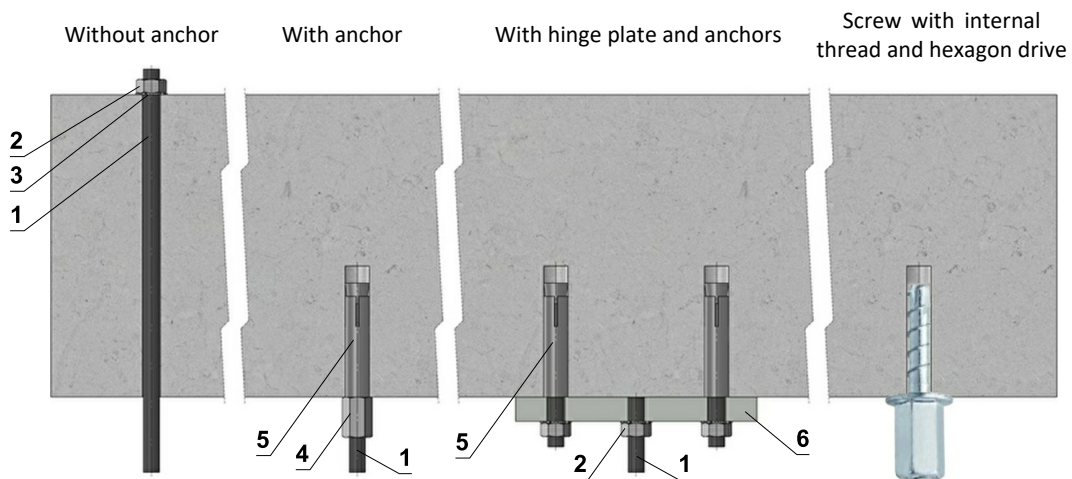

Hinge plates

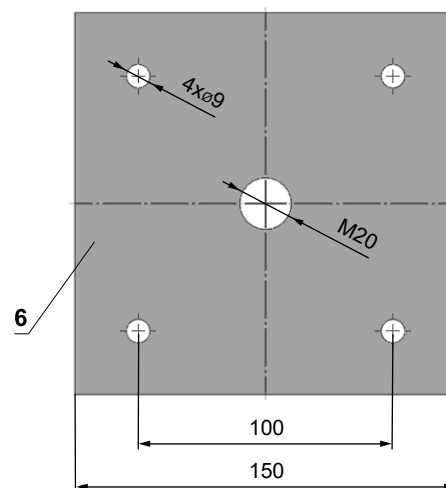
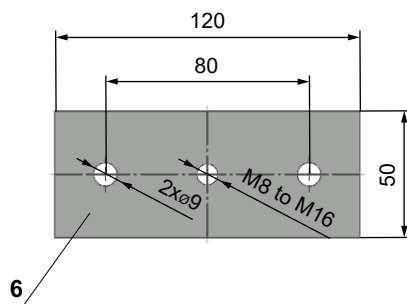

- If in doubt, always consult an anchor specialist engineer such as Halfen or Hilti.

Load capacities of threaded rods at the required fire resistance 60 min. $t \le 120 \text{ min.}$

Size	As [mm ²]	Weight [kg]	
		for 1 rod	for 2 rods
M8	36,6	22	44
M10	58	35	70
M12	84,3	52	104
M16	157	96	192
M18	192	117	234
M20	245	150	300

- 1 Threaded rod M8 - M20
- 2 Nut M8 - M20
- 3 Washer for M8 - M20
- 4 Coupling Nut M8 - M20
- 5 Anchor
- 6 Hinge plate - min. thickness 10 mm
- 7 Concrete screw tested for fire resistance R30-R90, max. Tension up to 0.75 KN (length 35 mm)

Example of placing of mounting profiles HILTI

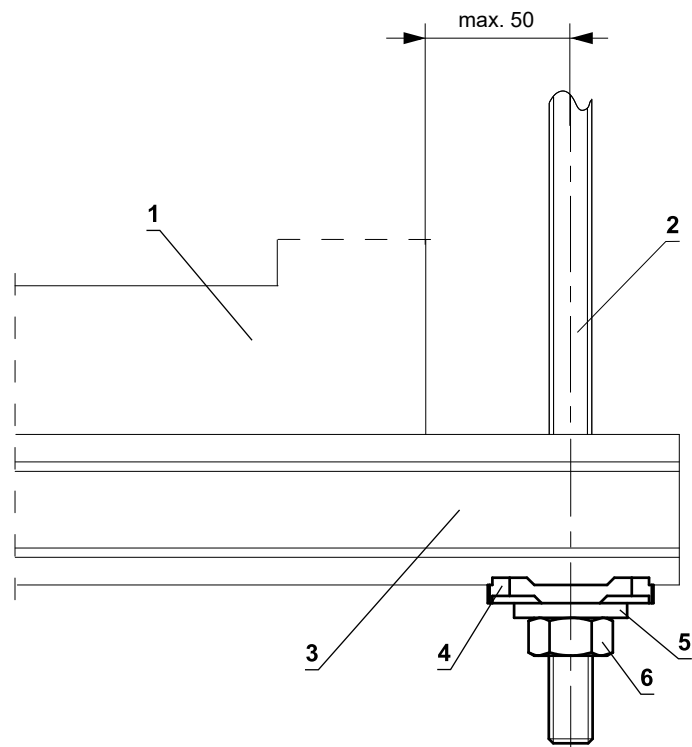
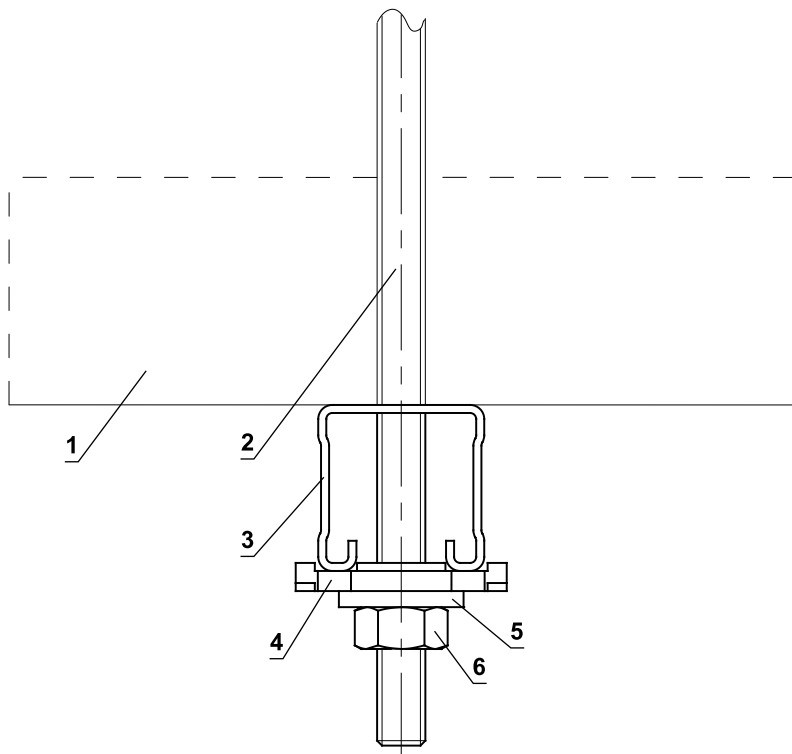

- 1 MSD
- 2 Threaded rod M8 - M12
- 3 Support HILTI MQ-41 or MQ-41/3
- 4 Bored plate HILTI MQZ-L
- 5 Washer for M8 - M12
- 6 Nut M8 - M12

Example of duct connection

Connection to smoke extract duct acc. to EN 1366-8 (MULTI) / to EN 1366-9 (SINGLE)

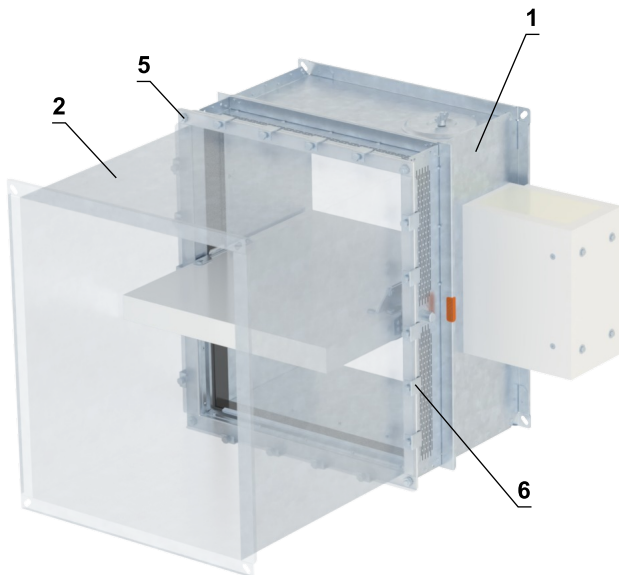
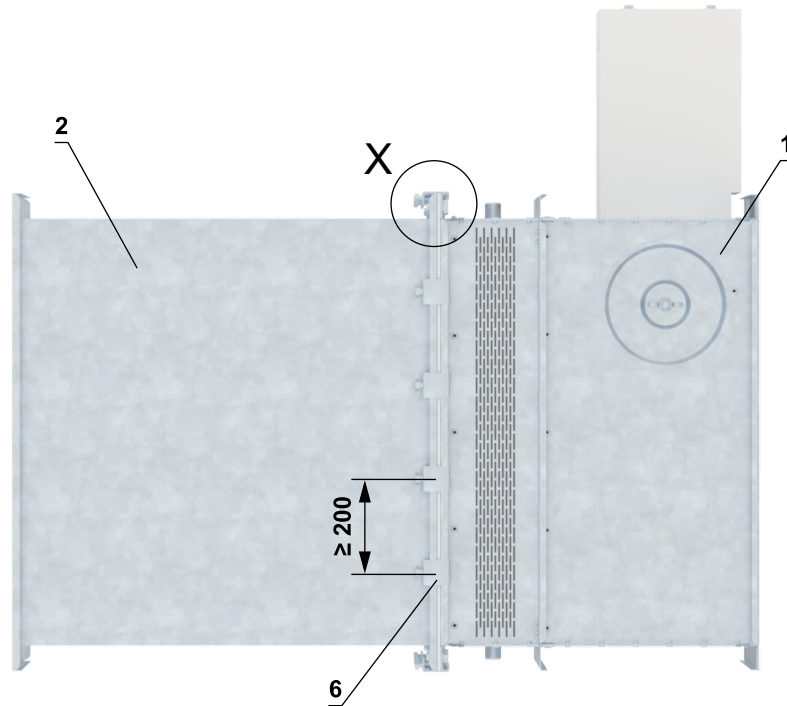

Electrically conductive connection

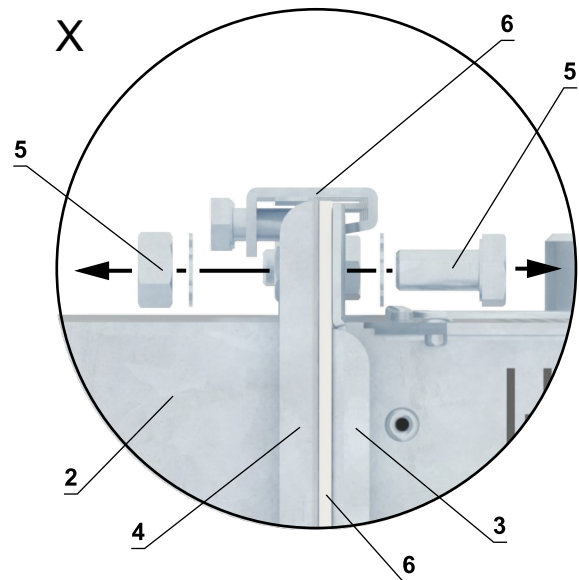

- 1 MSD
- 2 Duct
- 3 Flange of MSD
- 4 Flange of duct
- 5 M8 bolt assembly (bolt M8x20 mm, 2 pcs lock washer M8, nut M8) *
- 6 Ceramic selfadhesive sealing tape - around the duct circumference (type according to duct manufacturer instructions)
- 7 M8 C-clamps - maximum spacing of C-clamps 200 mm (type according to duct manufacturer instructions)

* min. one connection must be electrically conductive

VI. TECHNICAL DATA

Pressure loss

Pressure loss calculation

$$\Delta p = \xi \cdot \rho \cdot \frac{w^2}{2}$$

Δp	[Pa]	pressure loss
w	[m/s]	air flow speed in nominal damper section
ρ	[kg/m ³]	air density
ξ	[-]	coefficient of local pressure loss for the nominal damper section → see page 54

Determination of pressure loss by using diagram $\rho = 1,2 \text{ kg/m}^3$

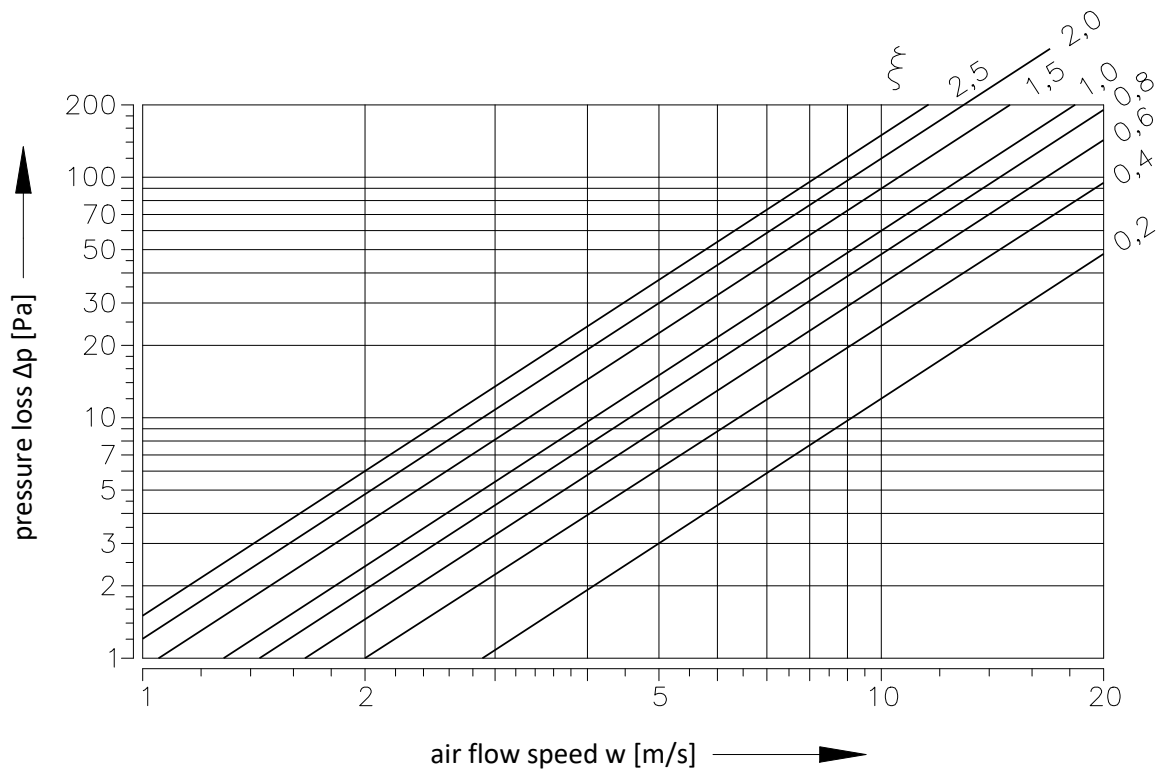

Coefficient of local pressure loss of square dampers

B										
A	180	200	225	250	280	300	315	355	400	450
180	2,1314	1,6906	1,3782	1,1149	1,0037	0,9288	0,7918	0,6827	0,6003	0,5350
200	1,9945	1,5804	1,2423	1,0368	0,9748	0,8785	0,7383	0,6367	0,5585	0,4976
225	1,9207	1,5162	1,1256	0,9994	0,9341	0,8442	0,7137	0,6078	0,5329	0,4772
250	1,8415	1,4584	1,1032	0,9651	0,9009	0,8068	0,6837	0,5832	0,5125	0,4590
280	1,7505	1,3782	1,0732	0,9116	0,8571	0,7597	0,6484	0,5543	0,4847	0,4366
300	1,6853	1,3311	1,0400	0,8635	0,8046	0,7148	0,6099	0,5264	0,4665	0,4109
315	1,6071	1,2690	1,0037	0,8303	0,7597	0,6645	0,5864	0,5050	0,4419	0,3927
355	1,5408	1,2155	0,9544	0,7929	0,7083	0,6356	0,5607	0,4815	0,4227	0,3756
400	1,4841	1,1706	0,9063	0,7651	0,6859	0,6227	0,5382	0,4633	0,4045	0,3606
450	1,4359	1,1331	0,8913	0,7394	0,6666	0,5896	0,5200	0,4473	0,3916	0,3478
500	1,3996	1,1021	0,8624	0,7201	0,6548	0,5810	0,5061	0,4344	0,3799	0,3371
550	1,3803	1,0882	0,8378	0,7073	0,6474	0,5757	0,4965	0,4269	0,3734	0,3349
560	1,3643	1,0754	0,8282	0,7009	0,6324	0,5725	0,4922	0,4227	0,3692	0,3285
600	1,3493	1,0582	0,8218	0,6944	0,6270	0,5585	0,4858	0,4184	0,3659	0,3242
630	1,3332	1,0497	0,8100	0,6837	0,6238	0,5436	0,4804	0,4130	0,3606	0,3199
650	1,3204	1,0379	0,7907	0,6752	0,6003	0,5393	0,4740	0,4066	0,3542	0,3157
700	1,3108	1,0304	0,7832	0,6741	0,5949	0,5382	0,4719	0,4045	0,3531	0,3146
710	1,3043	1,0272	0,7747	0,6688	0,5896	0,5371	0,4697	0,4034	0,3520	0,3135
750	1,2926	1,0176	0,7683	0,6634	0,5842	0,5307	0,4633	0,3980	0,3478	0,3103
800	1,2808	1,0079	0,7618	0,6559	0,5767	0,5222	0,4601	0,3959	0,3456	0,3060
900	1,2594	0,9908	0,7479	0,6441	0,5692	0,5136	0,4526	0,3884	0,3381	0,3007
1000	1,2433	0,9780	0,7383	0,6367	0,5607	0,4976	0,4462	0,3831	0,3338	0,2975
1100	1,2284	0,9662	0,7287	0,6281	0,5478	0,4869	0,4408	0,3777	0,3296	0,2932
1250	1,2155	0,9544	0,7126	0,6206	0,5339	0,4804	0,4355	0,3734	0,3264	0,2900
1400	1,2027	0,9459	0,6998	0,6142	0,5254	0,4783	0,4301	0,3692	0,3231	0,2857
1500	1,1952	0,9395	0,6955	0,6110	0,5157	0,4708	0,4280	0,3670	0,3199	0,2846

B										
A	500	550	560	600	630	650	700	710	750	800
180	0,4879	0,4665	0,4462	0,4216	0,4109	0,3916	0,3884	0,3820	0,3681	0,3585
200	0,4526	0,4323	0,4152	0,3959	0,3820	0,3681	0,3606	0,3552	0,3424	0,3328
225	0,4355	0,4152	0,4002	0,3788	0,3681	0,3531	0,3456	0,3413	0,3338	0,3221
250	0,4216	0,4002	0,3809	0,3659	0,3542	0,3403	0,3328	0,3274	0,3210	0,3092
280	0,3948	0,3766	0,3585	0,3435	0,3328	0,3199	0,3167	0,3114	0,2975	0,2932
300	0,3766	0,3531	0,3435	0,3253	0,3157	0,3071	0,2996	0,2953	0,2814	0,2750
315	0,3574	0,3349	0,3264	0,3103	0,3007	0,2932	0,2846	0,2782	0,2696	0,2611
355	0,3413	0,3253	0,3114	0,2975	0,2868	0,2750	0,2718	0,2664	0,2557	0,2493
400	0,3274	0,3082	0,2985	0,2900	0,2761	0,2654	0,2589	0,2557	0,2472	0,2386
450	0,3167	0,2964	0,2889	0,2782	0,2654	0,2589	0,2525	0,2461	0,2386	0,2301
500	0,3071	0,2943	0,2803	0,2664	0,2579	0,2482	0,2429	0,2386	0,2311	0,2236
550	0,3039	0,2857	0,2771	0,2611	0,2450	0,2365	0,2301	0,2268	0,2279	0,2194
560	0,2996	0,2825	0,2729	0,2515	0,2504	0,2408	0,2290	0,2268	0,2236	0,2172
600	0,2943	0,2793	0,2707	0,2493	0,2482	0,2375	0,2268	0,2247	0,2194	0,2140
630	0,2910	0,2761	0,2664	0,2482	0,2450	0,2343	0,2268	0,2247	0,2161	0,2119
650	0,2900	0,2707	0,2632	0,2461	0,2418	0,2322	0,2258	0,2236	0,2140	0,2097
700	0,2868	0,2654	0,2622	0,2450	0,2408	0,2301	0,2247	0,2226	0,2129	0,2087
710	0,2846	0,2632	0,2600	0,2440	0,2397	0,2290	0,2226	0,2215	0,2119	0,2076
750	0,2814	0,2611	0,2568	0,2397	0,2365	0,2268	0,2204	0,2194	0,2108	0,2054
800	0,2793	0,2600	0,2547	0,2354	0,2333	0,2236	0,2183	0,2172	0,2087	0,2022
900	0,2739	0,2547	0,2504	0,2333	0,2301	0,2172	0,2151	0,2129	0,2044	0,1990
1000	0,2696	0,2515	0,2461	0,2290	0,2268	0,2151	0,2119	0,2087	0,2001	0,1958
1100	0,2664	0,2482	0,2429	0,2258	0,2236	0,2129	0,2097	0,2065	0,1969	0,1937
1250	0,2632	0,2429	0,2397	0,2226	0,2204	0,2076	0,2065	0,2044	0,1947	0,1905
1400	0,2611	0,2397	0,2375	0,2204	0,2183	0,2044	0,2033	0,2022	0,1926	0,1894
1500	0,2589	0,2386	0,2365	0,2183	0,2161	0,2022	0,2012	0,2001	0,1905	0,1883

Coefficient of local pressure loss of round dampers

ØD	180	200	225	250	280	315	355	400	450	500	560	630
ξ	3,546	2,124	1,291	0,877	0,609	0,438	0,328	0,255	0,205	0,173	0,147	0,127

Noise data

Level of acoustic output corrected with filter A

$$L_{WA} = L_{W1} + 10 \log(S) + K_A$$

L_{WA}	[dB(A)]	level of acoustic output corrected with filter A
L_{W1}	[dB]	level of acoustic output L_{W1} related to the 1 m ² section
S	[m ²]	duct cross section
K_A	[dB]	correction to the weight filter A

Level of acoustic output L_{W1} [dB] related to the 1 m² section - square dampers

w [m/s]	ξ [-]											
	0,2	0,3	0,4	0,5	0,6	0,7	0,8	0,9	1	1,5	2	2,5
2	15,5	18,7	20,9	22,6	24	25,2	26,3	27,2	28	31,2	33,4	35,1
3	26,1	29,2	31,5	33,2	34,6	35,8	36,9	37,8	38,6	41,7	44	45,7
4	33,6	36,7	39	40,7	42,1	43,3	44,3	45,3	46,1	49,2	51,5	53,2
5	39,4	42,5	44,8	46,5	47,9	49,1	50,2	51,1	51,9	55	57,3	59
6	44,1	47,3	49,5	51,3	52,7	53,9	54,9	55,8	56,6	59,8	62	63,8
7	48,2	51,3	53,5	55,3	56,7	57,9	58,9	59,8	60,7	63,8	66,1	67,8
8	51,6	54,8	57	58,8	60,2	61,4	62,4	63,3	64,1	67,3	69,5	71,3
9	54,7	57,9	60,1	61,8	63,2	64,4	65,5	66,4	67,2	70,4	72,6	74,3
10	57,4	60,6	62,8	64,6	66	67,2	68,2	69,1	70	73,1	75,3	77,1
11	59,9	63,1	65,3	67,1	68,5	69,7	70,7	71,6	72,4	75,6	77,8	79,6
12	62,2	65,4	67,6	69,3	70,7	71,9	73	73,9	74,7	77,9	80,1	81,8

Level of acoustic output L_{W1} [dB] related to the 1 m² section - round dampers

w [m/s]	ξ [-]											
	0,1	0,2	0,3	0,4	0,6	0,8	1,0	1,5	2	2,5	3	3,5
2	9	11,5	14,7	16,9	20,1	22,3	24,1	27,2	29,4	31,2	32,6	33,8
3	16,7	22,1	25,3	27,5	30,7	32,9	34,6	37,8	40	41,7	43,2	44,4
4	24,2	29,6	32,8	35	38,1	40,4	42,1	45,3	47,5	49,2	50,7	51,9
5	30	35,4	38,6	40,8	44	46,2	47,9	51,1	53,3	55,1	56,5	57,7
6	34,8	40,2	43,3	45,6	48,7	51	52,7	55,8	58,1	59,8	61,2	62,4
7	38,8	44,2	47,3	49,6	52,7	55	56,7	59,9	62,1	63,8	65,2	66,4
8	42,3	47,7	50,8	53,1	56,2	58,4	60,2	63,3	65,6	67,3	68,7	69,9
9	45,4	50,7	53,9	56,1	59,3	61,5	63,3	66,4	68,6	70,4	71,8	73
10	48,1	53,5	56,6	58,9	62	64,3	66	69,1	71,4	73,1	74,5	75,7
11	50,6	56	59,1	61,4	64,5	66,7	68,5	71,6	73,9	75,6	77	78,2
12	52,8	58,2	61,4	63,6	66,8	69,0	70,7	73,9	76,1	77,9	79,3	80,5

Correction to the weight filter A - square and round dampers

w [m/s]	2	3	4	5	6	7	8	9	10	11	12
K_A [dB]	-15	-11,8	-9,8	-8,4	-7,3	-6,4	-5,7	-5	-4,5	-4	-3,6

Level of acoustic output in octave ranges

$$L_{Woct} = L_{W1} + 10 \log(S) + L_{rel}$$

L_{Woct}	[dB]	spectrum of acoustic output in octave range
L_{W1}	[dB]	level of acoustic output L_{W1} related to the 1 m ² section
S	[m ²]	duct cross section
L_{rel}	[dB]	relative level expressing the shape of the spectrum

Relative level expressing the shape of the spectrum L_{rel} - square and round dampers

w [m/s]	f [Hz]							
	63	125	250	500	1000	2000	4000	8000
2	-4,5	-6,9	-10,9	-16,7	-24,1	-33,2	-43,9	-56,4
3	-3,9	-5,3	-8,4	-13,1	-19,5	-27,6	-37,4	-48,9
4	-3,9	-4,5	-6,9	-10,9	-16,7	-24,1	-33,2	-43,9
5	-4	-4,1	-5,9	-9,4	-14,6	-21,5	-30,0	-40,3
6	-4,2	-3,9	-5,3	-8,4	-13,1	-19,5	-27,6	-37,4
7	-4,5	-3,9	-4,9	-7,5	-11,9	-17,9	-25,7	-35,1
8	-4,9	-3,9	-4,5	-6,9	-10,9	-16,7	-24,1	-33,2
9	-5,2	-3,9	-4,3	-6,4	-10,1	-15,6	-22,7	-31,5
10	-5,5	-4	-4,1	-5,9	-9,4	-14,6	-21,5	-30
11	-5,9	-4,1	-4	-5,6	-8,9	-13,8	-20,4	-28,8
12	-6,2	-4,3	-3,9	-5,3	-8,4	-13,1	-19,5	-27,6

VII. MATERIAL, FINISHING

- Damper casings are made from galvanized sheet metal without further surface treatment.
- Damper blades and actuator cover are made from fire resistant asbestos free boards made of mineral fibres.
- Fasteners are galvanized.
- According to the customer's requirements, dampers can be made of stainless steel material.
- Specifications for stainless-steel design:
 - Class A2 – Food-grade stainless steel (AISI 304 – EN 1.4301)
 - Class A4 – Chemistry-grade stainless steel (AISI 316, 316L – EN 1.4401, EN 1.4404)

The respective stainless steel is the material for all components that are located or entering the damper inner space; components outside the damper casing are typically from galvanised sheet metal (fasteners for mounting the actuator).

The following components, including the fasteners, are made from stainless steel at all times:

- 1) Damper casing and all components permanently attached
- 2) Blade holders including pins, metal parts of blades
- 3) Control components inside the damper (L-profile, pin with lever, rod, fasteners)
- 4) Inspection opening cover including the stirrup and fasteners (if they are parts of the cover)
- 5) Bearing for torque transfer from the lever with pin on the blade L-profile (made from AISI 440C)

The damper blade is made from boards of homogeneous material Promatect-H, connected with "U" clips on the outside, sealed with Promat K84 glue.

Plastic, rubber and silicon components, sealants, foaming tapes, glass-ceramic seals, housings, brass bearings of the blade, actuators are identical for all material variants of the dampers.

Some fasteners and components are only available in one class of stainless steel; the type will be used in all stainless-steel variants.

The damper blade in the variant for chemical environments (Class A4) is always treated with a coating of chemically resistant Promat SR.

Any other requirements for the design will be considered atypical and will be addressed on an individual basis.

VIII. TRANSPORTATION, STORAGE AND WARRANTY

Logistic terms

- Dampers are delivered on pallets. As standard, the dampers are wrapped in plastic foil for protection during transport and must not be used for long-term storage. Temperature changes during transport can cause condensation of water inside the packaging and thereby cause corrosion of materials used in the dampers (e.g. white corrosion on zinc-coated items or mould on calcium silicate). Therefore, it is necessary to remove the transport packaging immediately after unloading to allow air to circulate around the product.
- The dampers must be stored in clean, dry, well ventilated and dust-free environment out of direct sunlight. Ensure protection against moisture and extreme temperatures (minimum temperature +5°C). The dampers must be protected against mechanical and accidental damage prior to installation.
- Another required packaging system should be approved and agreed by manufacturer. Packaging material is not returnable in case that another packaging system (material) is required and used and it is not included into final price of damper.
- Dampers are transported by box freight vehicles without direct weather impact, there must not occur any shocks and ambient temperature must not exceed +50°C. Dampers must be protected against impact when transported and manipulated. During transportation, the damper blade must be in the "CLOSED" position.
- Dampers must be stored indoor in environment without any aggressive vapours, gases or dust. Indoor temperature must be in the range from -30°C to +50°C and maximum relative humidity 95%.

Warranty

- The manufacturer provides a warranty of 24 months from the date of dispatch for the dampers.
- In case of using a Schischek actuator, the manufacturer provides a 12-month warranty for the actuator from the date of shipment.
- The warranty for dampers MSD, provided by the manufacturer, is completely void if actuating, closing and control devices are unprofessionally handled by untrained workers or if electric components, i.e. limit switches, actuators, communication and supply devices and thermoelectric activation devices are dismounted.
- The warranty is void if dampers are used for other purposes, devices and working conditions than those allowed by these technical conditions or if the dampers are mechanically damaged during handling.
- If the dampers are damaged by transport, a record must be written down with the forwarder at reception for later complaint.

IX. ASSEMBLY, ATTENDANCE AND MAINTENANCE

- Assembly, maintenance and damper function check can be done only by qualified and trained person, i.e. "AUTHORIZED PERSON" according to the manufacturer documentation. All works done on the fire dampers must be done according international and local norms and laws.
- All effective safety standards and directives must be observed during damper assembly.
- To ensure reliable damper function it is necessary to avoid blocking the actuating mechanism and contact surfaces with collected dust, fibre and sticky materials and solvents.
- Flange and screw joints must be conductively connected to protect against dangerous contact. 2 galvanized lock washers that are placed under the head of one screw and a fastened nut are used for conductive connection.

Manual operation - actuator control without electric voltage

- A special wrench (part of the actuator) can be used to manually turn the damper blade to any position. When the wrench is turned in the direction of the arrow, the damper blade rotates to its open position. As the blade rotation is stopped, in every position, the actuator will be locked. Unlocking is possible even manually as per instructions on the actuator, or by the activation of the supply voltage.

Installation / fixing the damper

- The damper casing shall not be deformed in the course of bricking in.
- Once the damper is built in, the damper blade shall not grind on the damper casing during opening or closing.

Protection of the damper casing against buckling during installation, especially for large sizes!

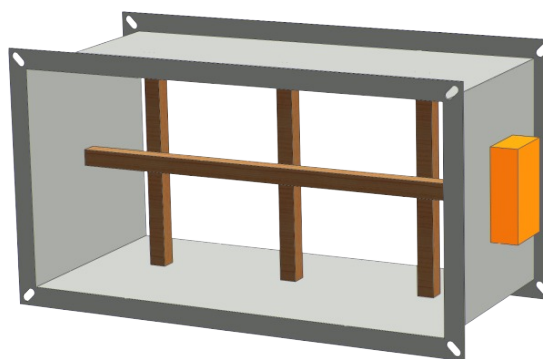
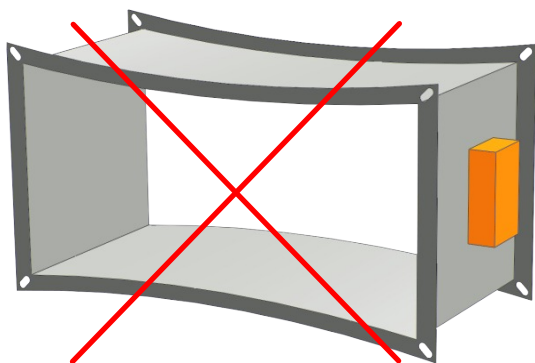

Protective cladding boards

- Protective cladding boards must be used as part of the penetration filling of installation with Ablative Coated Batt.
- Can be ordered from MANDIK (installed on the damper or as an accessory) or can be sourced from local supplier
- If protective cladding boards are required, this must be specified in the ordering key
- Protective cladding boards are made of PROMATECT-MST, thickness 30 mm.
- Glue K84 is not included in the package

Installation procedure

- 1) Apply K84 glue over the entire surface
- 2) Attach protective cladding boards on all sides of a fire damper and glue them on the damper casing
- 3) Screw parts A and B using four screws 5x70 mm
- 4) Completely fill the gaps with glue

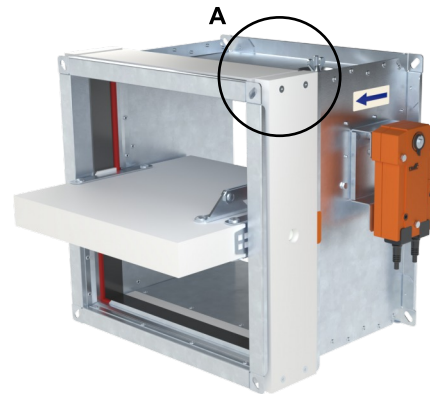
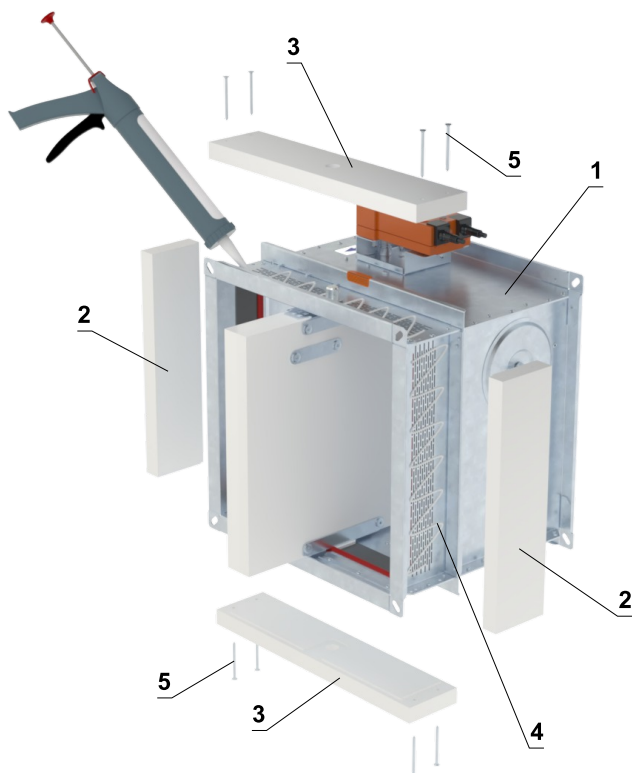

DETAIL A

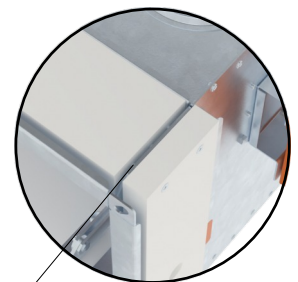

Completely fill the gaps between boards!

- 1 MSD
- 2 Part A
- 3 Part B
- 4 Glue PROMAT K-84
- 5 Screw 5x70 mm

Part A

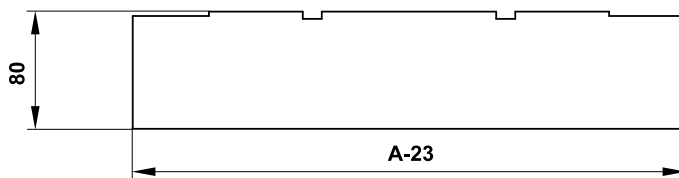

Part B

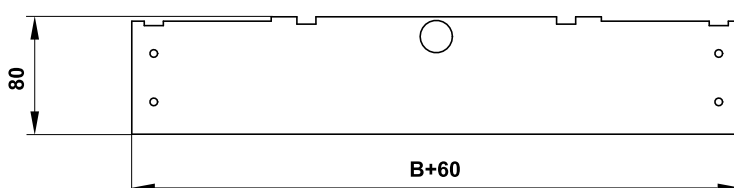

- Detailed dimensions of protective cladding boards on request.

Electrical connection of the actuator in protection box

protection box without slot or predrilled holes

- Drill two holes into the protection box (from outside to inside) and pull through field wiring cables (CAT 3 fire resistant cables as BS 8519) to connect to the actuator trailing lead inside the housing, using a standard screwed cable connector block, the protection box is made of calcium silicate plates.
- Procedure
 - Use drill (drill size acc. To suit connecting cable $\varnothing + 2$ mm for seal up by mastic) and make two holes. It is possible to drill holes in any side of the housing.
 - Pull the heat resistant cable through the calcium silicate plate (wall) and connect with cables from actuator acc. To electrical diagram → see pages 6 to 9
 - Seal up the space around cable with fire resistant mastic (HILTI CFS-S ACR, PROMASTOP) or equivalent.
 - Let the mastic harden

Example of drilled holes

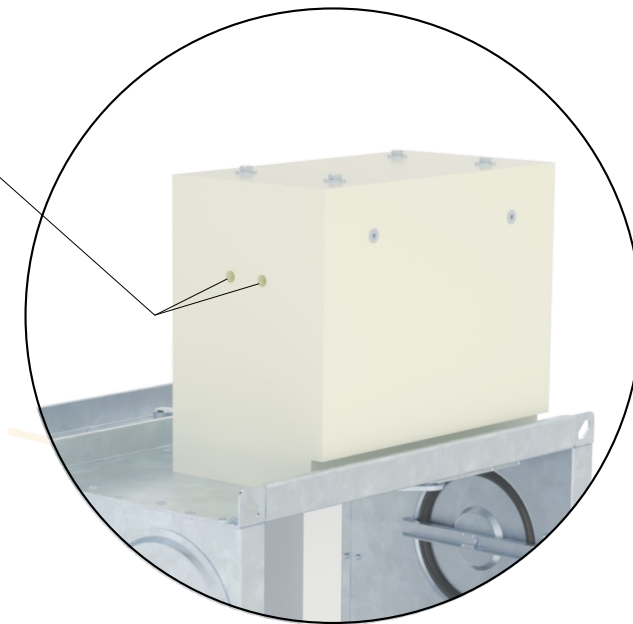

Example of position of holes in the wall of the box, without pre-manufactured slot

Entry into service and revisions

- Before entering the dampers into operation after assembly and after sequential revisions, checks and functionality tests of all designs including operation of the electrical components must be successfully provided and finished. After entering into operation, these revisions must be done according to requirement set by national regulations.
- In case that dampers are found unable to serve for their function for any cause, it must be clearly marked. The operator is obliged to ensure that the damper is put into condition in which it is ready for function and meanwhile he is obliged to provide the fire protection by another appropriate way.
- Removing the inspection hole cover
 - Unscrew four of the edge screws to release the cover and then remove it from its original position.
- Results of regular checks, imperfections found and all-important facts connected with the damper function must be recorded in the "FIRE BOOK" and immediately reported to the operator.
- Before entering the dampers into operation after their assembly and by sequential checks, the following checks must be carried out for all designs.
- Visual inspection of proper damper integration, inside damper area, damper blade, contact surfaces and silicon sealing.

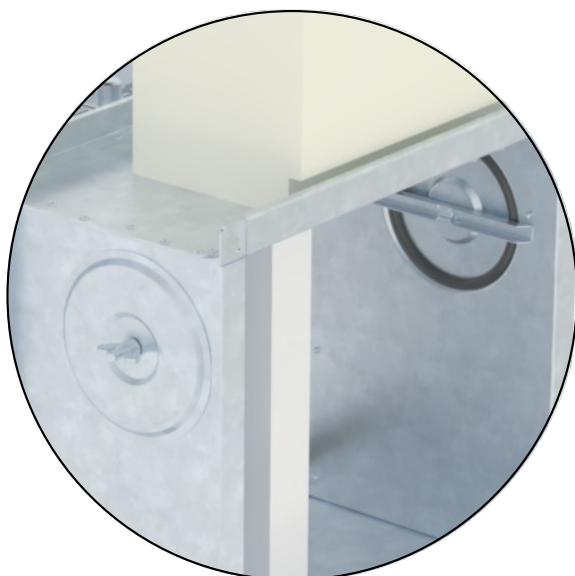

Inspection hole detail

- Ensure each damper is fully checked for operational capability, control should be initiated from the control system. Dampers blades should open and close correctly and operation should be visually inspected and documented prior to handover.

X. ORDERING INFORMATIONS

Ordering key MSD

Square damper MSD



EXAMPLE:

MSD EN 800x400/375 .44 IB1 Q30-ZN

Square smoke control damper MSD, dimension 800x400 mm, built length 375 mm, control design with spring return actuator 230 V, design includes protection box of the actuator and include the protective cladding boards in line with the blade, flange dimension 30 mm, galvanized material variant.

1 | Type of smoke control damper - MSD

2 | Country of destination

3 | Damper dimensions A x B → see pages 18 to 27

"A" is the width of the damper
 "B" is the height of the damper

4 | Built length - 375 mm

5 | Damper design

.44	With actuating mechanism BEN, BEE, BE, InMax 50.75-S for 230V
.54	With actuating mechanism BEN, BEE, BE, InMax 50.75-S for 24V
.65*	With actuating mechanism BEN (BEE)-SR for 24V

* Design .65 is not available by using actuating mechanism BE, InMax 50.75-S

6 | Accessories

	Without accessories
A	Design does not include protection box of the actuator and does not include protective cladding boards in line with the blade
A1	Design does not include protection box of the actuator and includes protective cladding boards in line with the blade
IB	Design includes protection box of the actuator and does not include the protective cladding boards in line with the blade
IB1	Design includes protection box of the actuator and include the protective cladding boards in line with the blade

7 | Flange dimension

Q30	Flange width 30 mm
-----	--------------------

8 | Material and other design options

ZN	Galvanized
A2	Stainless steel 1.4301 (AISI 304)
A4	Stainless steel 1.4404 (AISI 316L)

Round damper MSD



EXAMPLE:

MSD EN DN 500 .44 RS-ZN

Round smoke control damper MSD, dimension DN 500 mm, control design with spring return actuator 230 V, straight connection to circular duct, galvanized material variant.

1 | Type of smoke control damper - MSD

2 | Country of destination

3 | Damper dimensions ØD → see page 28

4 | Damper design

.44	With actuating mechanism BEN 230V
.54	With actuating mechanism BEN 24V

5 | Duct connection

RS	Straight connection to circular duct
----	--------------------------------------

6 | Material and other design options

ZN	Galvanized
A2	Stainless steel 1.4301 (AISI 304)
A4	Stainless steel 1.4404 (AISI 316L)

Ordering key MSD-W

Square damper MSD-W



EXAMPLE:

MSD-W EN 800x400/375 .44 Q30-ZN

Square smoke control damper MSD-W, dimension 800x400 mm, built length 375 mm, control design with spring return actuator 230 V, flange dimension 30 mm, galvanized material variant.

1| Type of smoke control damper - MSD-W

2| Country of destination

3| Damper dimensions A x B → see pages 18 to 27

"A" is the width of the damper
 "B" is the height of the damper

4| Built length - 375 mm

5| Damper design

.44	With actuating mechanism BEN 230V
.54	With actuating mechanism BEN 24V
.4M0	With actuating mechanism BFN 230, JOVENTA DAF2.20S with an electromagnet for 230V
.4M1	With actuating mechanism BFN 230, JOVENTA DAF2.20S with an electromagnet for 24V
.5M0	With actuating mechanism BFN 24, JOVENTA DAF1.20S with an electromagnet for 230V
.5M1	With actuating mechanism BFN 24, JOVENTA DAF1.20S with an electromagnet for 24V

6| Flange dimension

Q30	Flange width 30 mm
-----	--------------------

7| Material and other design options

ZN	Galvanized
A2	Stainless steel 1.4301 (AISI 304)
A4	Stainless steel 1.4404 (AISI 316L)

Round damper MSD-W



EXAMPLE:

MSD-W EN DN 400 .4M0 RS-ZN

Round smoke control damper MSD-W, dimension DN 400 mm, control design with spring return actuator 230 V, straight connection to circular duct, galvanized material variant.

1| Type of smoke control damper - MSD-W

2| Country of destination

3| Damper dimensions ØD → see page 28

4| Damper design

.4M0	With actuating mechanism BFN 230, JOVENTA DAF2.20S with an electromagnet for 230V
.4M1	With actuating mechanism BFN 230, JOVENTA DAF2.20S with an electromagnet for 24V
.5M0	With actuating mechanism BFN 24, JOVENTA DAF1.20S with an electromagnet for 230V
.5M1	With actuating mechanism BFN 24, JOVENTA DAF1.20S with an electromagnet for 24V

5| Duct connection

RS	Straight connection to circular duct
----	--------------------------------------

6| Material and other design options

ZN	Galvanized
A2	Stainless steel 1.4301 (AISI 304)
A4	Stainless steel 1.4404 (AISI 316L)

Data label

- Data label is placed on the damper casing (example)

MANDÍK [®]		MANDÍK, a.s. Dobříšská 550, 267 24 Hostomice, Czech Republic	
MULTI COMPARTMENT SMOKE CONTROL DAMPER - XXXX			
DIMENSION:	<input type="text"/>	DESIGN:	<input type="text"/>
SERIAL.NO.:	<input type="text"/>	WEIGHT (kg):	<input type="text"/>
CLASSIFICATION:		MANUAL	
TPM XXX/XX	Cert. No.: 1391-CPR-XXXX/XXXX, DoP: PM/XXXX/XX/XX/X	XX	EN 12101:2011
			 1391

The producer reserves the right for innovations of the product.
For actual product information see www.mandik.com

MANDÍK[®]
www.mandik.com

