

FDMQ

Fire damper

Technical Documentation

Installation, Commissioning, Operation, Maintenance and Service Manual

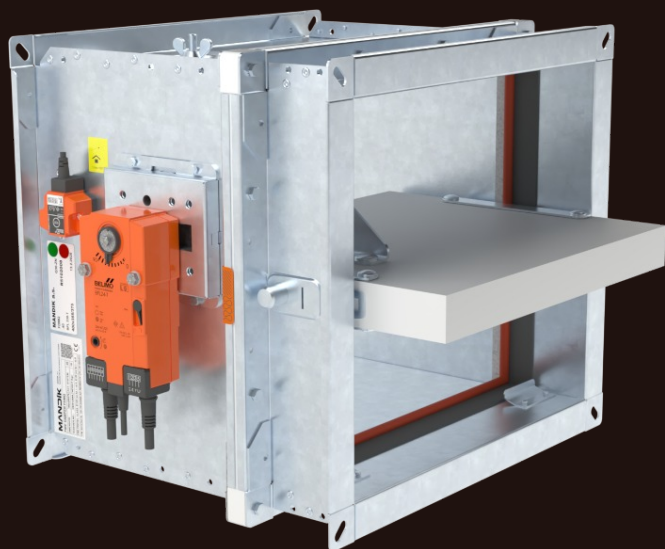

These technical specifications state a row of manufactured sizes and models of fire dampers FDMQ
It is valid for production, designing, ordering, delivery, maintenance and operation.

CONTENT

I. GENERAL.....	3	Commissioning and revisions.....	88
Description.....	3	X. ORDERING INFORMATIONS.....	90
II. DESIGN.....	4	Ordering key.....	90
Design with manual control.....	4	Accessories.....	92
Design with spring return actuator.....	6	Data label.....	93
Design with the communication and supply device	12		
III. DIMENSIONS.....	14		
Technical parameters.....	16		
IV. INSTALLATION.....	22		
Placement and installation.....	22		
Statement of installations.....	24		
In solid wall construction.....	25		
Installation outside solid wall construction.....	31		
In gypsum wall construction.....	34		
Installation outside gypsum wall construction.....	40		
Installation in sandwich wall construction.....	43		
Shaft walls.....	44		
In solid ceiling construction.....	47		
Outside solid ceiling construction.....	52		
Installation frames.....	54		
Installation frame E1.....	55		
Installation frame E2.....	59		
Installation frame E3.....	62		
Installation frame E4.....	64		
Installation frame E5.....	68		
Installation frame E6.....	71		
V. SUSPENSION SYSTEMS.....	74		
Example of duct connection.....	78		
VI. TECHNICAL DATA.....	79		
Pressure loss.....	79		
Noise data.....	81		
VII. MATERIAL, FINISHING.....	82		
VIII. TRANSPORTATION, STORAGE AND WARRANTY.....	83		
Logistic terms.....	83		
Warranty.....	83		
IX. ASSEMBLY, ATTENDANCE AND MAINTENANCE.....	84		

I. GENERAL

Description

Fire dampers are shutters in ducts of air-conditioning devices that prevent the spread of fire and combustion products from one fire segment to the other one by means of closing the duct in the points of fire separating constructions.

Damper blade automatically closes air duct using a closing spring or a spring return actuator. The closing spring is actuated by pressing a button on the manual control or by melting a thermal fuse.

The return spring of the actuator is actuated when a thermoelectric activation device BAT is activated, when a test button on BAT is pressed or when power supply of the actuator is interrupted.

After closing the blade, the damper is sealed with silicon against smoke penetration. On request by customer, the damper can be supplied silicon-free. In the closed position, the damper is also sealed with material which increases its volume due to increasing temperature and air proofs the air duct.

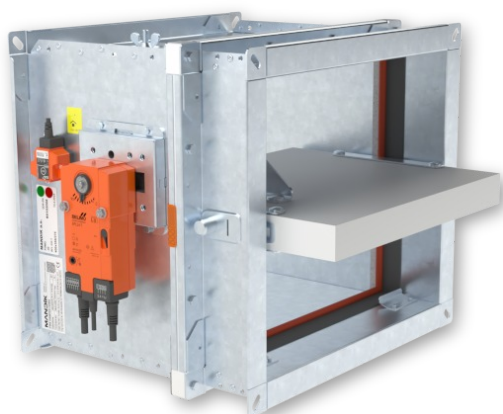

FDMQ with spring return actuator



FDMQ with manual control

Damper characteristics

- CE certified acc. to EN 15650
- Tested in accordance with EN 1366-2
- Classified acc. to EN 13501-3+A1
- External Casing leakage class ATC 3 (old marking "C"), Internal leakage class 2 acc. to EN 1751
- Cycling test in class C₁₀₀₀₀ acc. to EN 15650
- Corrosion resistant acc. to EN 15650
- Certificate of constancy of performance No. 1391-CPR-XXXX/XXXX
- Declaration of Performance No. PM/FDMQ/01/XX/X
- Hygienic assessment of fire dampers - Report No. 1.6/pos/19/19b

Working conditions

- Exact damper function is provided under the following conditions:
 - maximum air velocity 12 m/s
 - maximum pressure difference 1200 Pa
 - the air circulation in the whole damper section must be secured steady over the entire surface.
- Dampers can be installed in arbitrary position
- Dampers are suitable for systems without abrasive, chemical and adhesive particles.
- Dampers are designed for macroclimatic areas with mild climate according to EN IEC 60 721-3-3 ed.2., class 3K22. (Environment 3K22 is typically protected place with regulated temperature)
- Temperature in the place of installation is permitted to range from -30°C to +50°C.

II. DESIGN

Design with manual control

Design .01

- Design with manual control with a thermal fuse which actuates the shutting device, after the nominal activation temperature 72°C has been reached.
- Automatic initiation of the manual control is not activated if the temperature does not exceed 70°C.
- In case that other activation temperatures are required, thermal fuses with nominal activation temperature +104°C or +147°C can be supplied (this requirement must be specified in the order).



Design .01

ATTENTION:

- Manual controls are produced in four sizes M2 to M5, difference is only in size of a closing spring, which closes the fire damper.
- For the size of fire dampers is always assigned the size of the manual control → see pages 16 to 21
- It is not recommended to use different size of the manual control than given by the manufacturer, otherwise there is a risk of damaging the fire damper.

Design .11

- Design .01 with manual control can be complemented with a limit switch signaling of the damper blade position "CLOSED".
- Cable is connected directly to limit switch.
- Limit switch detail → see page 5

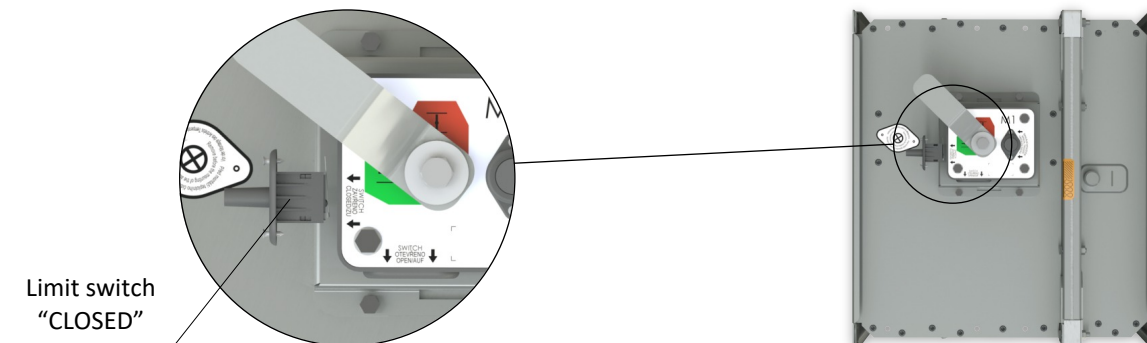

Design .11

Design .80

- Design .01 with manual control can be complemented with two limit switches signaling of the damper blade position "CLOSED" and "OPEN".
- Cables are connected directly to limit switches.
- Limit switch detail → see page 5

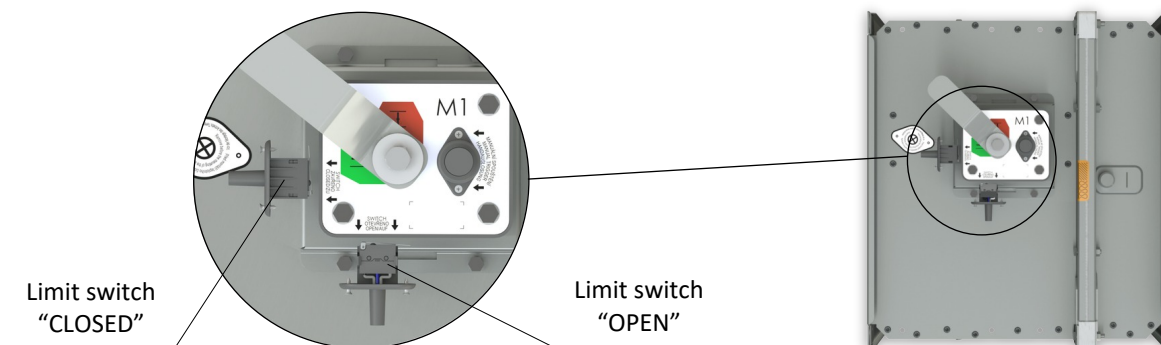

Design .80

Manual control

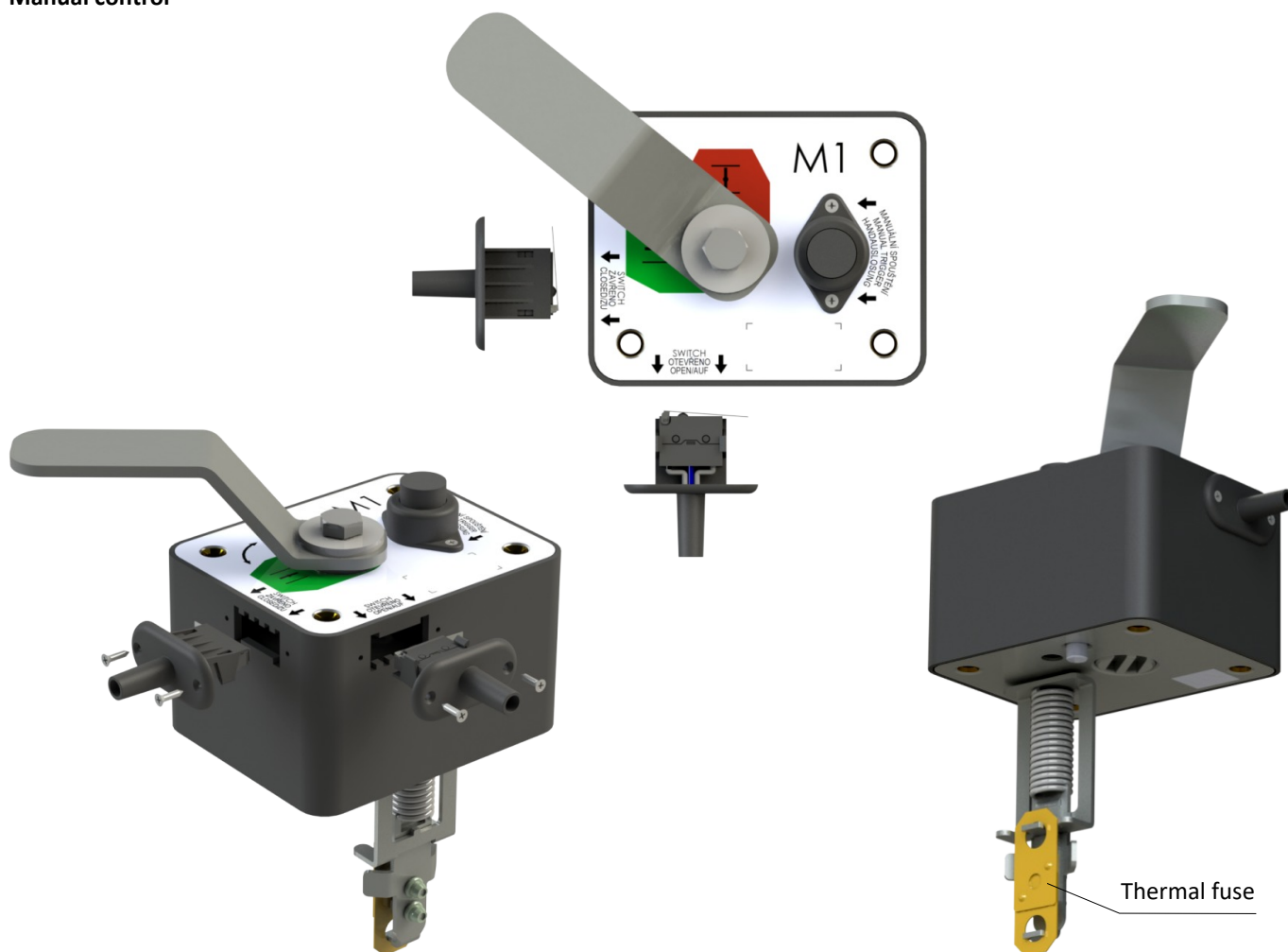

Limit switch G905-300E03W1

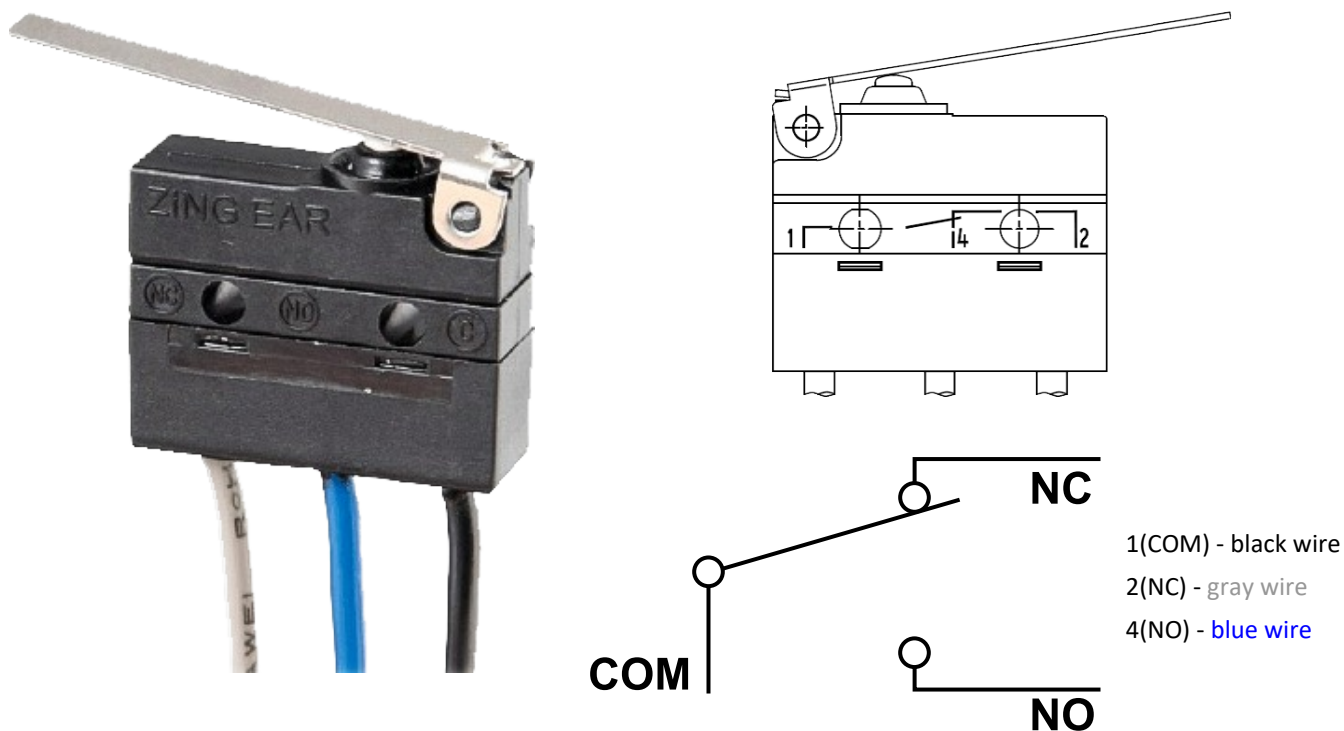

Nominal voltage and maximal current	AC 230V / 5A
Class of protection	IP 67
Working temperature	-25°C ... +120°C

This limit switch is possible to connect in two following ways

- CUT-OFF if the arm is moving ... connect wire 1+2
- SWITCH-ON if the arm is moving ... connect wire 1+4

Design with spring return actuator

Design .40 and .50

- The fire dampers are equipped with Belimo spring return actuators with thermoelectric activation device BAT. The spring return actuator types are BFL, BFN or BF depending on the damper size. (Further mentioned as „actuator“).
- After being connected to power supply 230V or AC/DC 24V, the actuator rotates the damper blade to the operating position "OPEN" and at the same time pre-stretches its return spring.
- When the actuator is power supplied, the damper blade is in the position "OPEN" and the return spring is pre-stretched.
- Time needed for full opening of the damper blade from the position "CLOSED" to the position "OPEN" is maximum 120 sec. If the actuator power supply is interrupted (due to loss of supply voltage, or pressing a test button on the thermoelectric activation device BAT), the actuator rotates the damper blade to the breakdown position "CLOSED".
- The time of closing the damper blade from the position "OPEN" to the position "CLOSED" takes maximum 20 sec.
- In case that the power supply is restored again (the blade can be in any position), the actuator starts to rotate the damper blade back to the position "OPEN".
- A thermoelectric activation device BAT, which contains two thermal fuses Tf1 and Tf2, is an integral part of the actuator.
- These fuses are activated when temperature +72°C has been reached (the fuse Tf1 due to temperature outside the duct and the fuse Tf2 due to temperature inside the duct). The thermoelectric activation device can also be equipped with a Tf2 thermal fuse type ZBAT 95/120/140 (must be specified in the order). In this case, the activation temperature inside the duct is +95°C, +120°C or +140°C (depending on the type).
- After the thermal fuse Tf1 or Tf2 has been activated, the power supply is permanently and irreversibly interrupted and the actuator, by means of the pre-stretched spring, rotates the damper blade into the breakdown position "CLOSED".
- Signalisation of damper blade position "OPEN" and "CLOSE" is provided by two microswitches.

Thermoelectric activation device BAT

Spring return actuator

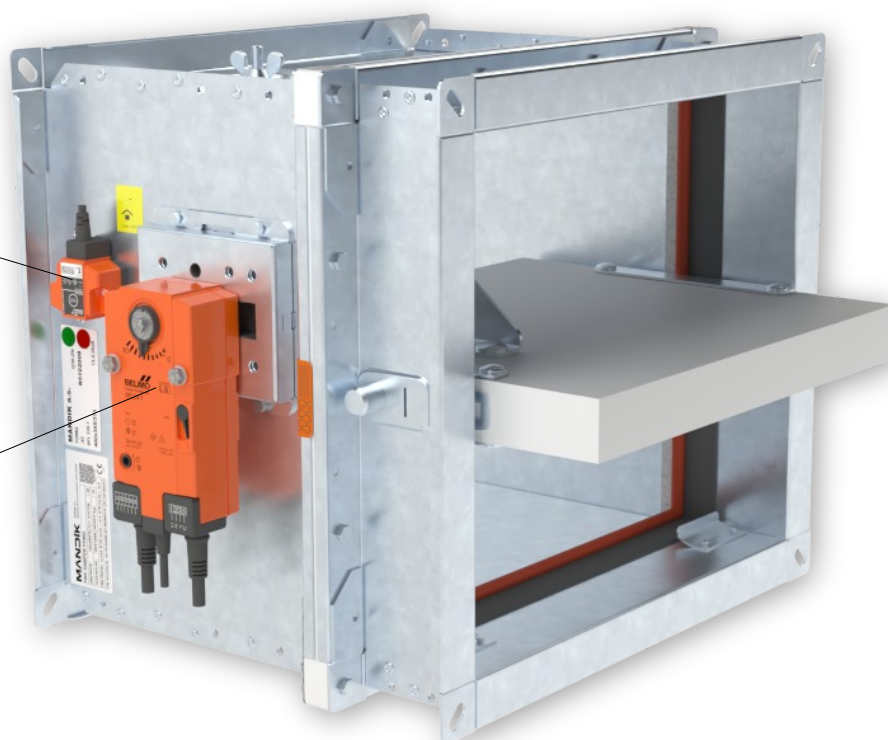

Design .40 and .50

Actuator BELIMO BFL 230-T

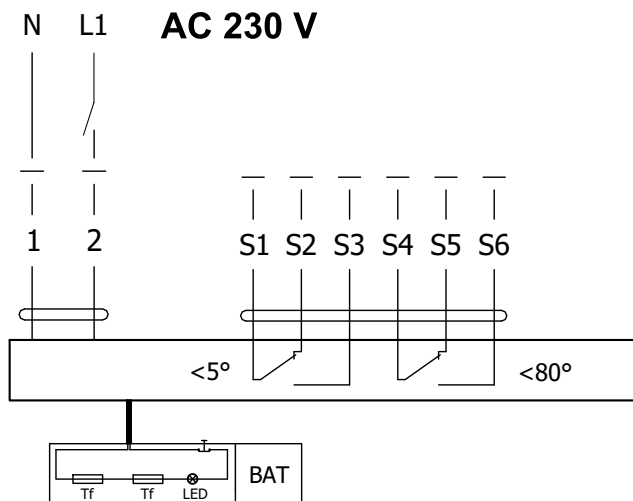

Actuator BELIMO BFL 24-T(-ST)

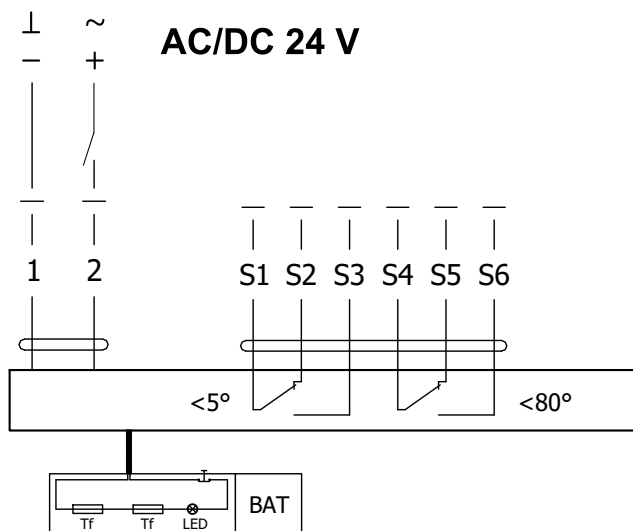

Actuator BELIMO BFL 230-T(-ST), BFL 24-T(-ST)

Actuator BELIMO - 4 Nm/ 3 Nm Spring	BFL 230-T(-ST)	BFL 24-T(-ST)
Power voltage	AC 230 V 50/60Hz	AC/DC 24 V 50/60Hz
Power consumption - in operation - in rest position	2,6 W 0,7 W	2,0 W 0,7 W
Dimensioning	4 VA (I _{max} 4 A @ 5 ms)	2,8 VA (I _{max} 2,9 A @ 5 ms)
Protection class	II	III
Degree of protection	IP 54	
Running time - motor - spring return	<math>< 60\text{ s}</math> $\sim 20\text{ s}$	
Ambient temperature - normal duty - safety duty - non-operating temperature	-30°C ... +55°C The safe position will be attained up to max. +75°C -40°C ... +55°C	
Connection - supply/control - auxiliary switch	cable 1 m, 2 x 0,75 mm ² (BFL 2xx-T-ST) with 3-pin plug-in connectors cable 1 m, 6 x 0,75 mm ² (BFL 2xx-T-ST) with 6-pin plug-in connectors	
Response temperature thermal fuse	duct outside temperature +72°C duct inside temperature +72°C	

Actuator BELIMO BFN 230-T

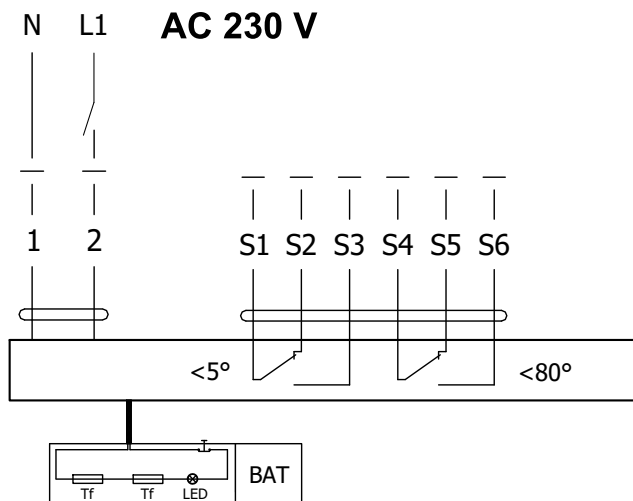

Actuator BELIMO BFN 24-T(-ST)

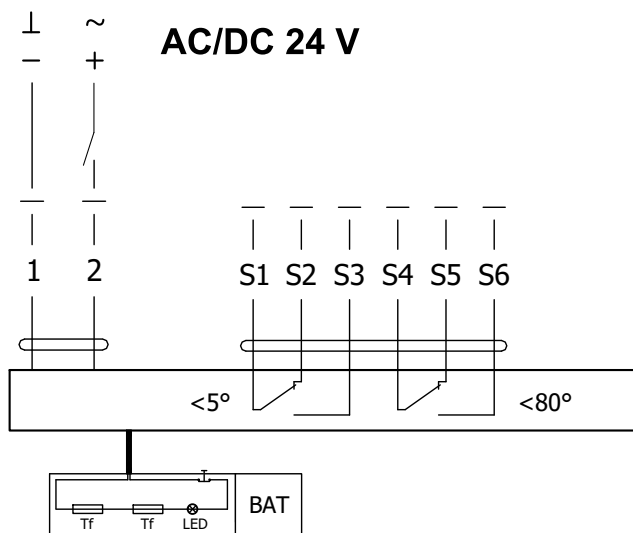

Actuator BELIMO BFN 230-T(-ST), BFN 24-T(-ST)

Actuator BELIMO - 9 Nm/ 7 Nm Spring	BFN 230-T(-ST)	BFN 24-T(-ST)
Power voltage	AC 230 V 50/60Hz	AC/DC 24 V 50/60Hz
Power consumption - in operation	3,5 W	3,2 W
- in rest position	1,3 W	1,2 W
Dimensioning	6,5 VA (Imax 4 A @ 5 ms)	4,3 VA (Imax 2,9 A @ 5 ms)
Protection class	II	III
Degree of protection	IP 54	
Running time - motor	< 60 s	
- spring return	~ 20 s	
Ambient temperature	-30°C ... +55°C	
- normal duty	The safe position will be attained up to max. +75°C	
- safety duty		
- non-operating temperature	-40°C ... +55°C	
Connection - supply/control	cable 1 m, 2 x 0,75 mm ² (BFN 2xx-T-ST) with 3-pin plug-in connectors	
- auxiliary switch	cable 1 m, 6 x 0,75 mm ² (BFN 2xx-T-ST) with 6-pin plug-in connectors	
Response temperature thermal fuse	duct outside temperature +72°C duct inside temperature +72°C	

Actuator BELIMO BF 230-TN

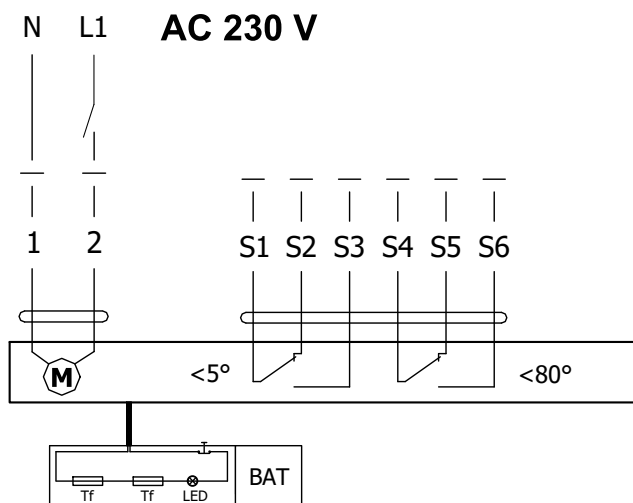

Actuator BELIMO BF 24-TN (-ST)

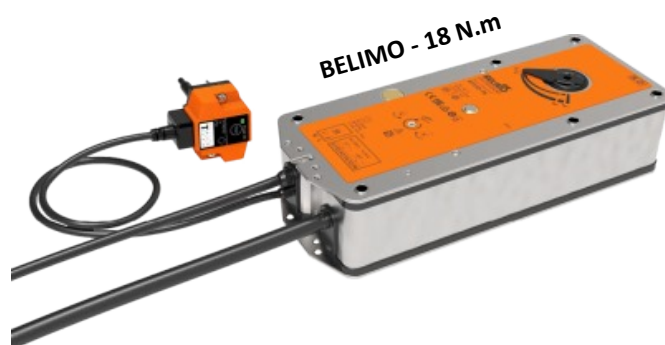
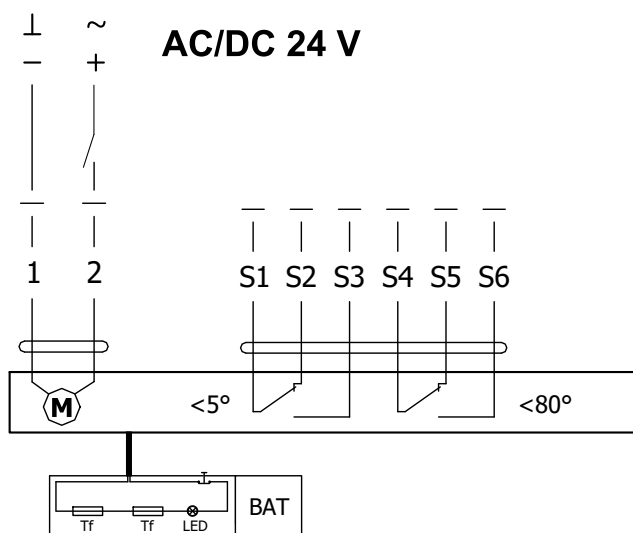

Actuator BELIMO BF 230-TN(-ST), BF 24-TN(-ST)

Actuator BELIMO - 18 Nm/ 12 Nm Spring	BF 230-TN(-ST)	BF 24-TN(-ST)
Power voltage	AC 230 V 50/60Hz	AC/DC 24 V 50/60Hz
Power consumption - in operation - in rest position	8,5 W 3 W	7 W 2 W
Dimensioning	11 VA (I _{max} 8,3 A @ 5 ms)	10 VA (I _{max} 8,3 A @ 5 ms)
Protection class	II	III
Degree of protection	IP 54	
Running time - motor - spring return	120 s ~ 16 s	
Ambient temperature - normal duty - safety duty - non-operating temperature	-30°C ... +50°C The safe position will be attained up to max. +75°C -40°C ... +50°C	
Connection - supply/control - auxiliary switch	cable 1 m, 2 x 0,75 mm ² (BF 2xx-TN-ST) with 3-pin plug-in connectors cable 1 m, 6 x 0,75 mm ² (BF 2xx-TN-ST) with 6-pin plug-in connectors	
Response temperature thermal fuse	duct outside temperature +72°C duct inside temperature +72°C	

Thermoelectric activation device BAT

- If the thermal fuse Tf1 is interrupted (due to temperature outside the duct), it is necessary to replace the spring return actuator. Thermoelectric activation device BAT is integral part of the actuator.
- If the thermal fuse Tf2 is interrupted (due to temperature inside the duct), only the spare part ZBAT 72 (95/120/140) needs to be replaced (acc.to the activation temperature).
- When one of the thermal fuses responds, the supply voltage is interrupted permanently and irreversibly.
- The function (interruption of the supply voltage) can be checked by pressing the test button.
- Installation is carried out with the pre-assembled, self-tapping screws.



BELIMO ZBAT 72
Black (BK) = 72°C (standard)



BELIMO ZBAT 95
Grey (GY) = 95°C

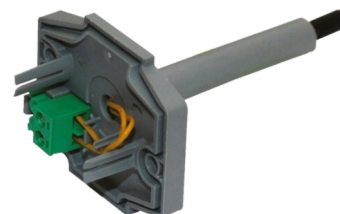

BELIMO ZBAT 120
Orange (OG) = 120°C

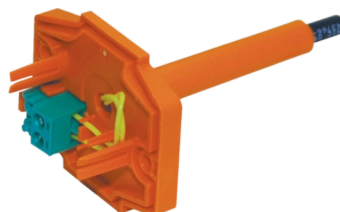

BELIMO ZBAT 140
Red (RD) = 140°C

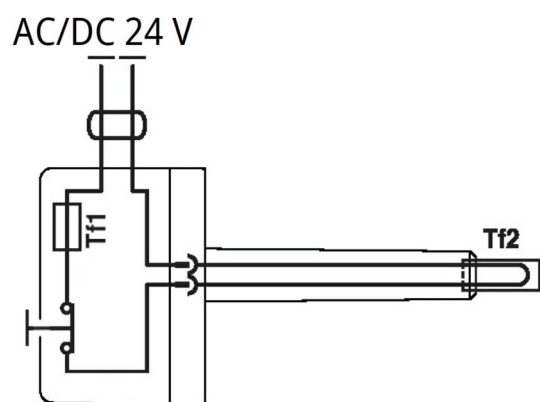
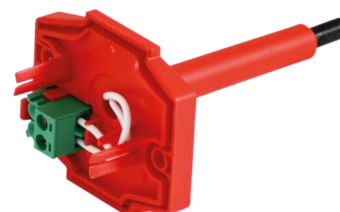

Thermoelectric activation device BAT 72 (95/120/140)

Power voltage	AC/DC 24 V 50/60Hz
Rated current	1 A
AC/DC throughput resistance	<1 Ω
Protection class	III
Degree of protection	IP 54
Probe length	65 mm
Ambient temperature	-30°C ... +50°C
Storage temperature	-40°C ... +50°C
Ambient humidity	Max. 95% RH, non-condensing
Connection supply	Cable 1 m, 2 x 0.5 mm ² , Betaflam cable heatresistant up to 145°C
Response temperature thermal fuse	Duct inside temperature +72 (95/120/140)°C Duct outside temperature +72 (95/120/140)°C

Design .41 and .51

- Design .41 or .51 with actuator and smoke detector ORS 142 K. The voltage can be AC 230 V or 24 V DC. Design .41 with voltage AC 230 V is equipped with communication and supply device BKN 230-24-MOD and with actuator BF 24-TN (BFL 24-T, BFN 24-T).
- The smoke detector is activated when smoke spreads in air duct system. Deactivation of the smoke detector alarm status is provided by interruption of supply voltage for min. 2s.
- Signalisation of damper blade position "OPEN" and "CLOSE" is provided by two microswitches.

Design .41 with actuator BF 24-TN (BFL, BFN 24-T), with smoke detector ORS 142 K and with supply device BKN 230-24-MOD (voltage AC 230 V)

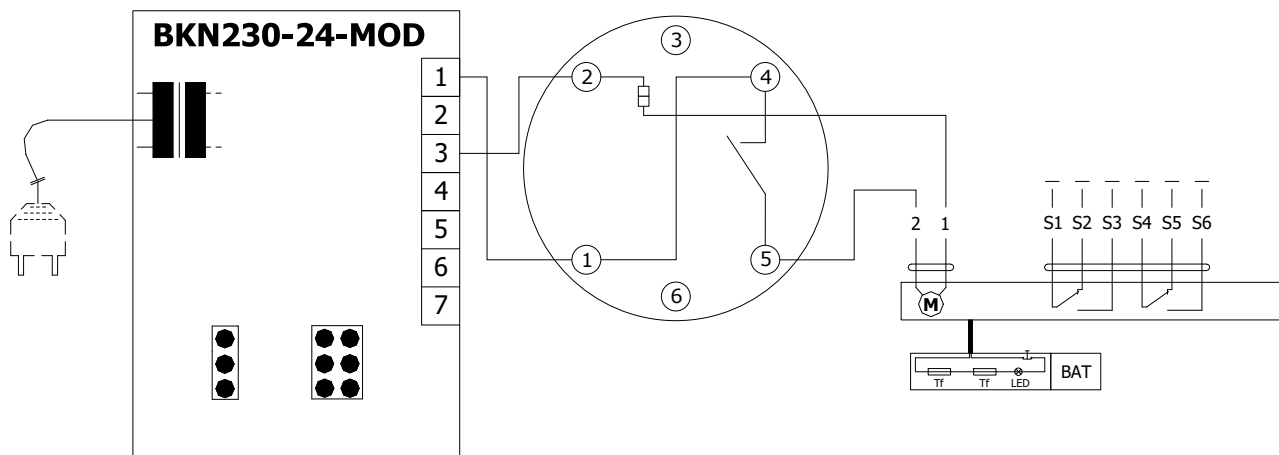

Design .51 with actuator BF 24-TN (BFL, BFN 24-T), with smoke detector ORS 142 K (voltage 24 V DC)

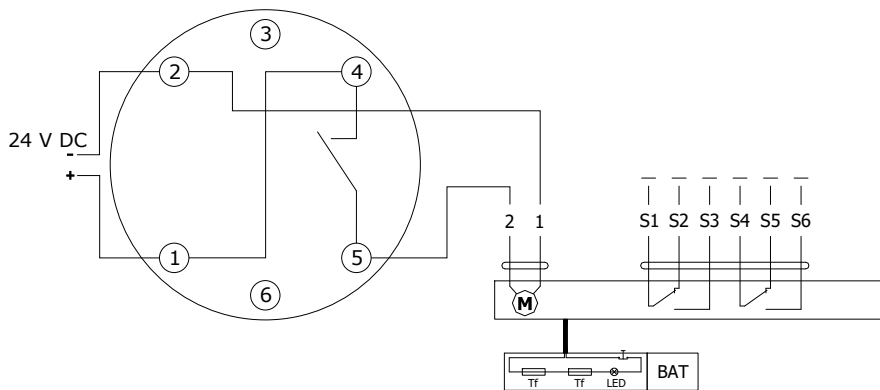

Communication and supply device BKN 230-24-MOD

Nominal voltage	AC 230 V 50/60Hz
Power consumption	3 W (operating position)
Dimensioning	14 VA (including actuator)
Protection Class	II
Degree of protection	IP 40
Ambient temperature	-20°C ... +50°C
Non-operating temperature	-40°C ... +80°C
Connection - net	cable 0,9 m with EURO plug type 26
- motor	6-pole connector, 3-pole connector
- terminal board	screw terminals for cable 2x1,5 mm ²

Design with the communication and supply device

Design .63, 63S

- Design with the communication and supply device BKN 230-24-MOD and actuator BF 24-TN-ST (BFL 24-T-ST, BFN 24-T-ST) for communication with control systems using the Modbus RTU or BACnet MS / TP. Design 63. can be extended with an optical smoke detector ORS 142 K (design .63S).
- The wiring of the line is to be carried out in accordance with applicable RS485 regulations.
- Parameterization of the communication is done using DIL switches.
- BKN 230-24-MOD can be installed separately, without a connection to a master control system, in which case the connection bridge between the terminals 1 and 4 must be installed.
- If the test button on BAT is pressed or if the power supply (e.g. by a signal from ELECTRICAL FIRE SIGNALISATION) is disconnected, the damper blade position will be "FAILURE".
- For design .63S the smoke detector is activated when smoke spreads in air duct system. Deactivation of the smoke detector alarm status is provided by interruption of supply voltage for min. 2s.

Design with communication and supply device BKN 230-24-MOD, with actuator BF 24-TN-ST (BFL 24-T-ST, BFN 24-T-ST) and smoke detector ORS 142 K

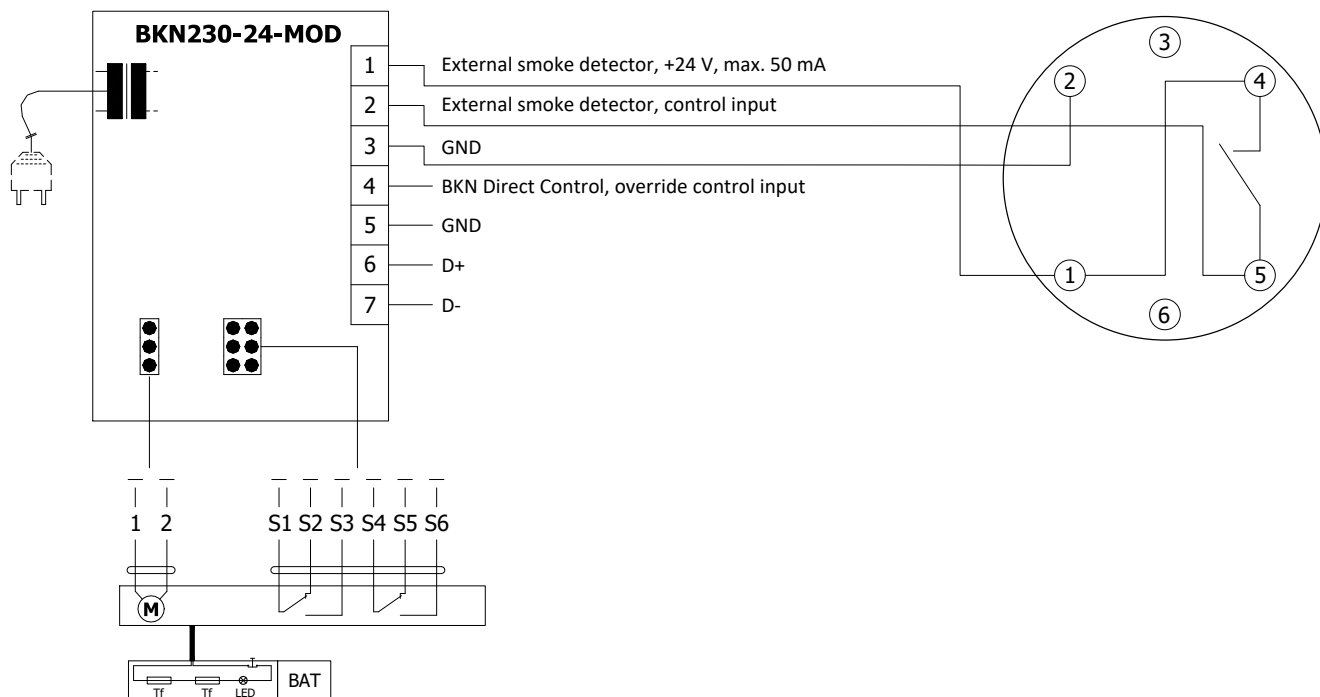

Communication and supply device BKN 230-24-MOD

Nominal voltage	AC 230 V 50/60Hz
Power consumption	3 W (operating position)
Dimensioning	14 VA (including actuator)
Protection Class	II
Degree of protection	IP 40
Ambient temperature	-20°C ... +50°C
Non-operating temperature	-40°C ... +80°C
Connection - net	cable 0,9 m with EURO plug type 26
- motor	6-pole connector, 3-pole connector
- terminal board	screw terminals for cable 2x1,5 mm ²

Optical smoke detector ORS 142 K with the socket 143A

- The smoke detector ORS 142 K is used for early smoke detection in rooms or inside the ventilation system.
- The sensor operates on the light scatter principle. Inside the scanning chamber is a light source and a light sensor, in the normal state the light from the source does not fall on the sensor. Only when smoke enters the scanning chamber the light is scattered and falls on the sensor.
- The smoke detector can be connected directly to the actuator (design .41 and .51) which, in case of smoke detection, passes to the safety position, or to the BKN communication and supply device (design .63).
- By early detection of smoke, it can be effectively prevented from spreading of smoke through the ventilation system. In addition to smoke detection, the sensor can distinguish and signal slight and heavy contamination, e.g. the presence of large amounts of dust.
- The ORS 142 K smoke detector has an alarm memory, i.e. if the alarm is triggered, the safety relay opens and stays in this state even if the smoke disappears from the scanning chamber. The sensor remains in the alarm state until the power supply is briefly reset.
- On the pin 3, an external device can be connected via RS-Bus communication to report the status of the sensor.
- Pin 6 has no connection to the detector and is designed as a load-bearing structure in the base.

ORS 142 K



Socket 143A



RS-Bus communication

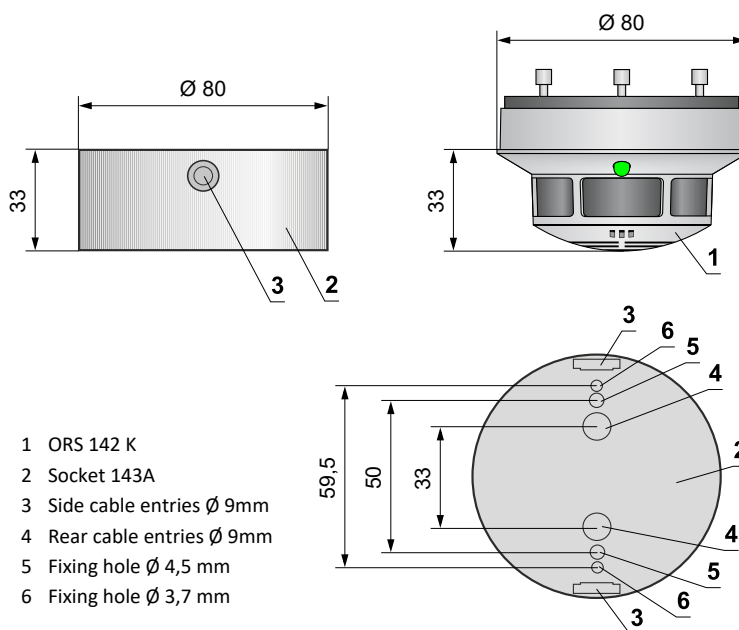
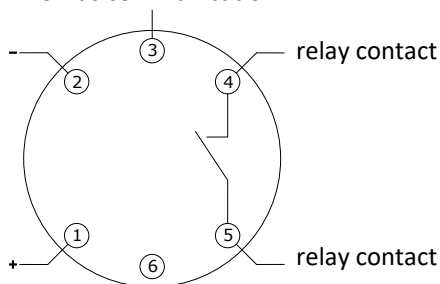

Relay contact		LED	
In operation		Green	Shines
Slight contamination		Green / Yellow	Flashes
Heavy contamination		Green / Yellow	Flashes
Fault		Yellow	Shines
Alarm		Red	Shines
Power Off		Off	-

- 1 ORS 142 K
- 2 Socket 143A
- 3 Side cable entries Ø 9mm
- 4 Rear cable entries Ø 9mm
- 5 Fixing hole Ø 4,5 mm
- 6 Fixing hole Ø 3,7 mm

Optical smoke detector ORS 142 K with the socket 143A

Operating voltage	18 ... 28 V DC
Residual ripple	≤ 200 mV
Power Consumption Socket (without actuator)	max. 22 mA
Degree of protection	IP 42
Ambient temperature	-20°C ... +75°C
Additional temperature sensor	+70°C
Connection - net	Cabel 1m, connected to terminals 1, 2 and 4
- motor	Actuator connected on the terminals 2 and 5
- communication and supply device BKN	Cabel 1m, connected to terminals 1, 2, 4 and 5

III. DIMENSIONS

FDMQ with manual control

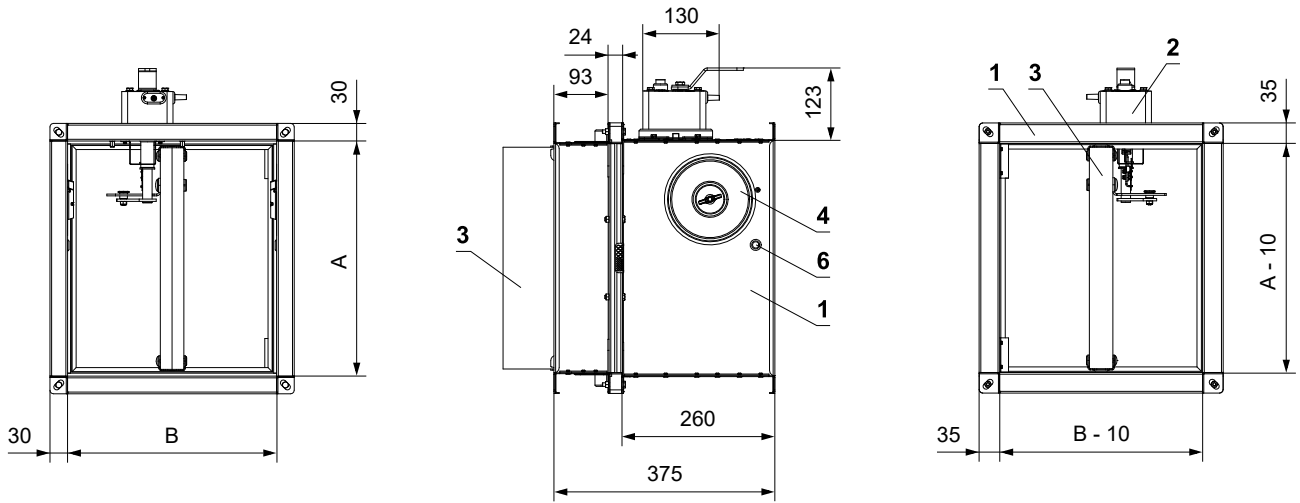

- 1 Damper casing
- 2 Manual control
- 3 Damper blade
- 4 Inspection opening cover
- 5 Sensor sticker
- 6 Hole for camera

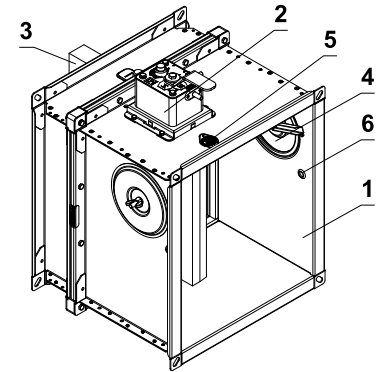
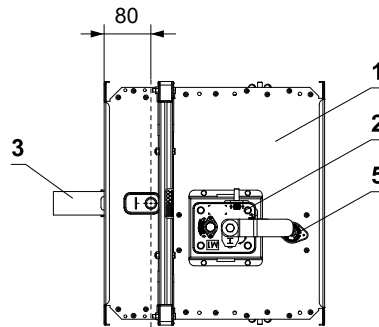

FDMQ with spring return actuator

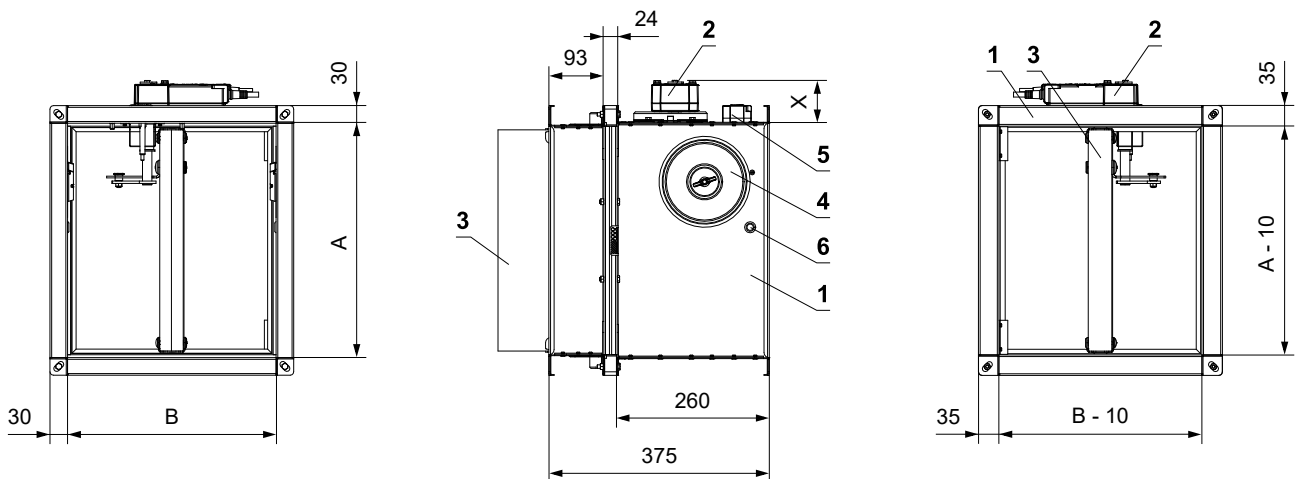

X=72 mm (BFL)
 X=76 mm (BFN)
 X=83 mm (BF)

- 1 Damper casing
- 2 Spring return actuator
- 3 Damper blade
- 4 Inspection opening cover
- 5 Thermoelectric activation device
- 6 Hole for camera

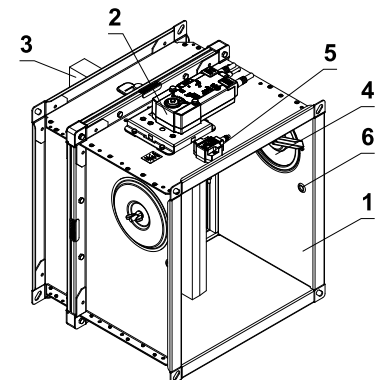
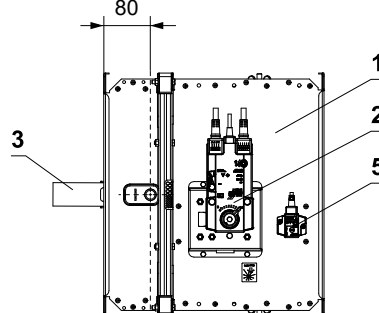

Damper blade overlaps

- Open damper blade overlaps the damper casing by the value "a" or "c". These values are specified in chapter Technical parameters → see pages 16 to 21

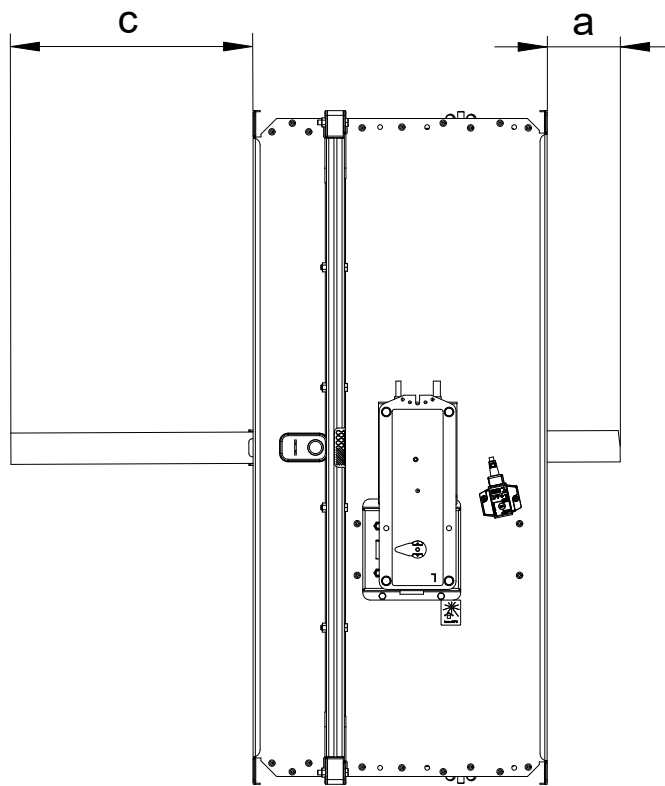

Values "a" and "c" has to be respected when projecting following air-conditioning duct.

Flange of a damper - CONTROL SIDE

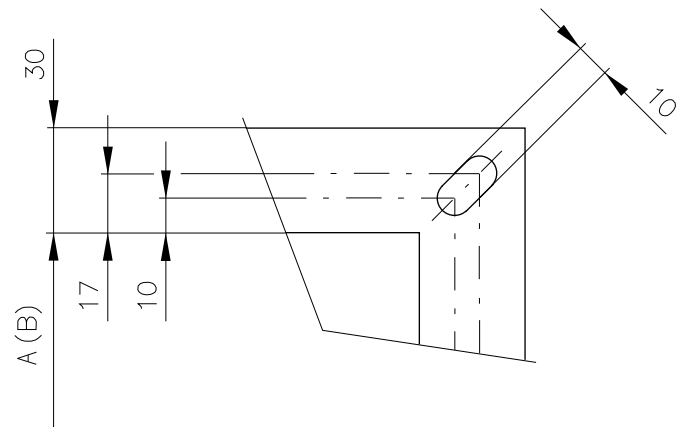

Flange of a damper - INSTALLATION SIDE

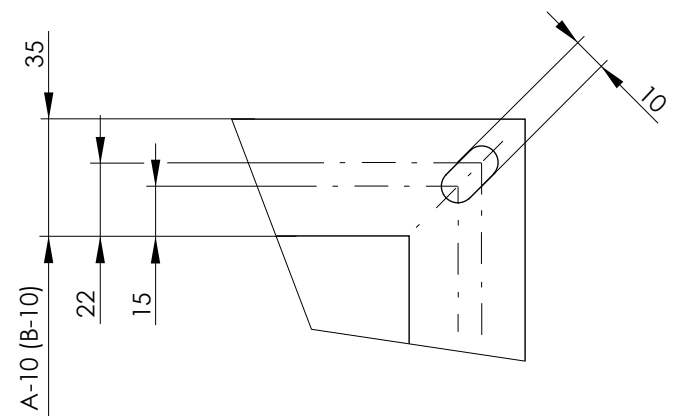

30 mm wide flanges are fitted with oval holes in the corners

Technical parameters

A x B [mm]	Damper blade overlaps		Weight		Free area S _r [m ²]	Spring return actuator	Manual control	A x B [mm]	Damper blade overlaps		Weight		Free area S _r [m ²]	Spring return actuator	Manual control	
	a [mm]	c [mm]	Man. [kg]	Actu. [kg]*					a [mm]	c [mm]	Man. [kg]	Actu. [kg]*				
150 x	-	-	8,4	8,5	0,0106	BFL	M2	200 x	650	18,5	233,5	16,5	16,7	0,1024	BFL	M2
	-	-	8,8	8,8	0,0144				700	43,5	258,5	17,2	17,4	0,1111		
	-	8,5	9	9,1	0,0169				710	48,5	263,5	17,3	17,5	0,1129		
	-	21	9,3	9,3	0,0200				750	68,5	283,5	17,9	18,1	0,1199		
	-	33,5	9,6	9,7	0,0231				800	93,5	308,5	18,6	18,9	0,1286		
	-	48,5	9,9	10	0,0269				150	-	-	9,3	9,3	0,0170		
	-	59	10,2	10,3	0,0294				180	-	-	9,8	9,9	0,0230		
	-	66	10,3	10,4	0,0313				200	-	8,5	10,2	10,3	0,0270		
	-	86	10,8	10,9	0,0363				225	-	21	10,6	10,7	0,0320		
	-	108,5	11,3	11,4	0,0419				250	-	33,5	11	11,1	0,0370		
	-	133,5	11,9	12	0,0481				280	-	48,5	11,5	11,6	0,0430		
	-	158,5	12,4	12,5	0,0544				300	-	59	11,9	12	0,0470		
	-	183,5	13	13,1	0,0606				315	-	66	12,1	12,2	0,0500		
	-	188,5	13,1	13,2	0,0619				355	-	86	12,8	12,9	0,0580		
-	208,5	13,5	13,7	0,0669	400	-	108,5	13,5	13,7	0,0670						
8,5	223,5	13,9	14,1	0,0706	225 x	450	-	133,5	14,4	14,5	0,0770					
-	-	8,8	8,9	0,0132	500	-	158,5	15,2	15,4	0,0870						
-	-	9,2	9,3	0,0178	550	-	183,5	16	16,2	0,0970						
-	8,5	9,5	9,6	0,0209	560	-	188,5	16,2	16,4	0,0990						
-	21	9,8	9,9	0,0248	600	-	208,5	16,8	17	0,1070						
-	33,5	10,2	10,3	0,0287	630	8,5	223,5	17,3	17,5	0,1130						
-	48,5	10,6	10,7	0,0333	650	18,5	233,5	17,6	17,9	0,1170						
-	59	10,8	10,9	0,0364	700	43,5	258,5	18,4	18,7	0,1270						
-	66	11	11,1	0,0388	710	48,5	263,5	18,6	18,8	0,1290						
-	86	11,6	11,7	0,0450	750	68,5	283,5	19,2	19,5	0,1370						
-	108,5	12,2	12,3	0,0519	800	93,5	308,5	20	20,3	0,1470						
180 x	-	133,5	12,9	13	0,0597	150	-	-	9,6	9,7	0,0191					
-	158,5	13,5	13,7	0,0674	180	-	-	10,2	10,3	0,0259						
-	183,5	14,2	14,3	0,0752	200	-	8,5	10,5	10,6	0,0304						
-	188,5	14,3	14,5	0,0767	225	-	21	11	11,1	0,0360						
-	208,5	14,9	15	0,0829	250	-	33,5	11,5	11,6	0,0416						
8,5	223,5	15,3	15,4	0,0876	280	-	48,5	12	12,1	0,0484						
18,5	233,5	15,5	15,7	0,0907	300	-	59	12,4	12,5	0,0529						
43,5	258,5	16,2	16,4	0,0984	315	-	66	12,7	12,8	0,0563						
48,5	263,5	16,3	16,5	0,1000	355	-	86	13,4	13,6	0,0653						
68,5	283,5	16,8	17	0,1062	400	-	108,5	14,3	14,4	0,0754						
93,5	308,5	17,5	17,7	0,1139	250 x	450	-	133,5	15,2	15,4	0,0866					
-	-	9	9,1	0,0149	500	-	158,5	16,1	16,3	0,0979						
-	-	9,5	9,6	0,0201	550	-	183,5	17	17,2	0,1091						
-	8,5	9,8	9,9	0,0236	560	-	188,5	17,2	17,4	0,1114						
-	21	10,2	10,3	0,0280	600	-	208,5	17,9	18,1	0,1204						
-	33,5	10,5	10,6	0,0324	630	8,5	223,5	18,4	18,7	0,1271						
-	48,5	11	11,1	0,0376	650	18,5	233,5	18,8	19	0,1316						
-	59	11,3	11,4	0,0411	700	43,5	258,5	19,7	19,9	0,1429						
-	66	11,5	11,6	0,0438	710	48,5	263,5	19,9	20,1	0,1451						
-	86	12,1	12,2	0,0508	750	68,5	283,5	20,6	20,8	0,1541						
-	108,5	12,8	12,9	0,0586	800	93,5	308,5	21,4	21,7	0,1654						
-	133,5	13,5	13,7	0,0674	150	-	-	9,9	10	0,0217						
-	158,5	14,3	14,4	0,0761	180	-	-	10,6	10,7	0,0293						
-	183,5	15	15,2	0,0849	200	-	8,5	11	11,1	0,0344						
-	188,5	15,2	15,3	0,0866	225	-	21	11,5	11,6	0,0408						
-	208,5	15,7	15,9	0,0936	250	-	33,5	12	12,1	0,0472						
8,5	223,5	16,2	16,4	0,0989	280	-	48,5	12,7	12,8	0,0548						

Sizes in increments of 5 mm can be manufactured on request.

* For designs with BKN a weight of 0.5 kg must be added.

A x B [mm]	Damper blade overlaps		Weight		Free area Sf [m²]	Spring return actuator	Manual control	A x B [mm]	Damper blade overlaps		Weight		Free area Sf [m²]	Spring return actuator	Manual control	
	a [mm]	c [mm]	Man. [kg]	Actu. [kg]*					a [mm]	c [mm]	Man. [kg]	Actu. [kg]*				
280 x	300	-	59	13,1	13,2	0,0599	BFL	315 x	710	48,5	263,5	23,1	23,4	0,1871	M2	
	315	-	66	13,4	13,5	0,0638			750	68,5	283,5	24	24,3	0,1987		BFN
	355	-	86	14,2	14,4	0,0740			800	93,5	308,5	25	25,4	0,2132		
	400	-	108,5	15,2	15,3	0,0854			150	-	-	10,8	10,9	0,0281	BFL	
	450	-	133,5	16,2	16,4	0,0982			180	-	-	11,6	11,7	0,0380		
	500	-	158,5	17,2	17,4	0,1109			200	-	8,5	12,1	12,2	0,0446		
	550	-	183,5	18,2	18,4	0,1237	225	-	21	12,8	12,9	0,0528				
	600	-	188,5	18,4	18,6	0,1262	250	-	33,5	13,4	13,6	0,0611				
	630	8,5	223,5	19,8	20	0,1441	280	-	48,5	14,2	14,4	0,0710				
	650	18,5	233,5	20,2	20,4	0,1492	300	-	59	14,7	14,9	0,0776				
	700	43,5	258,5	21,2	21,5	0,1619	315	-	66	15,1	15,3	0,0825				
	710	48,5	263,5	21,4	21,7	0,1645	355	-	86	16,2	16,4	0,0957				
	750	68,5	283,5	22,1	22,4	0,1747	400	-	108,5	17,3	17,5	0,1106				
	800	93,5	308,5	23,1	23,4	0,1874	450	-	133,5	18,6	18,8	0,1271				
300 x	150	-	-	10,2	10,3	0,0234	BFL	355 x	500	-	158,5	19,9	20,1	0,1436	BFL	
	180	-	-	10,8	10,9	0,0316			550	-	183,5	21,1	21,4	0,1601		
	200	-	8,5	11,3	11,4	0,0371			560	-	188,5	21,4	21,7	0,1634		
	225	-	21	11,9	12	0,0440			600	-	208,5	22,4	22,7	0,1766		
	250	-	33,5	12,4	12,5	0,0509			630	8,5	223,5	23,1	23,4	0,1865		
	280	-	48,5	13,1	13,2	0,0591			650	18,5	233,5	23,6	23,9	0,1931		
	300	-	59	13,5	13,7	0,0646	700		43,5	258,5	24,8	25,1	0,2096			
	315	-	66	13,9	14	0,0688	710		48,5	263,5	25	25,4	0,2129			
	355	-	86	14,7	14,9	0,0798	750		68,5	283,5	26	26,4	0,2261			
	400	-	108,5	15,7	15,9	0,0921	800		93,5	308,5	27,2	27,6	0,2426			
	450	-	133,5	16,8	17	0,1059	150		-	-	11,3	11,4	0,0319			
	500	-	158,5	17,9	18,1	0,1196	180		-	-	12,2	12,3	0,0431			
	550	-	183,5	19	19,2	0,1334	200		-	8,5	12,8	12,9	0,0506			
	560	-	188,5	19,2	19,4	0,1361	225		-	21	13,5	13,7	0,0600			
600	-	208,5	20	20,3	0,1471	250	-	33,5	14,3	14,4	0,0694					
630	8,5	223,5	20,7	21	0,1554	280	-	48,5	15,2	15,3	0,0806					
650	18,5	233,5	21,1	21,4	0,1609	300	-	59	15,7	15,9	0,0881					
700	43,5	258,5	22,1	22,4	0,1746	315	-	66	16,2	16,4	0,0938					
710	48,5	263,5	22,4	22,7	0,1774	355	-	86	17,3	17,5	0,1088					
750	68,5	283,5	23,2	23,5	0,1884	400	-	108,5	18,6	18,9	0,1256					
800	93,5	308,5	24,2	24,6	0,2021	450	-	133,5	20	20,3	0,1444					
315 x	150	-	-	10,3	10,4	0,0281	BFL	400 x	500	-	158,5	21,4	21,7	0,1631	BFL	
	180	-	-	11	11,1	0,0334			550	-	183,5	22,8	23,2	0,1819		
	200	-	8,5	11,5	11,6	0,0392			560	-	188,5	23,1	23,4	0,1856		
	225	-	21	12,1	12,2	0,0464			600	-	208,5	24,2	24,6	0,2006		
	250	-	33,5	12,7	12,8	0,0537			630	8,5	223,5	25	25,4	0,2119		
	280	-	48,5	13,4	13,5	0,0624			650	18,5	233,5	25,6	25,9	0,2194		
	300	-	59	13,9	14	0,0682	700		43,5	258,5	26,9	27,3	0,2381			
	315	-	66	14,2	14,4	0,0725	710		48,5	263,5	27,2	27,6	0,2419			
	355	-	86	15,1	15,3	0,0841	750		68,5	283,5	28,2	28,7	0,2569			
	400	-	108,5	16,2	16,4	0,0972	800		93,5	308,5	29,5	30	0,2756			
	450	-	133,5	17,3	17,5	0,1117	150		-	-	11,9	12	0,0361			
	500	-	158,5	18,4	18,7	0,1262	180		-	-	12,9	13	0,0489			
	550	-	183,5	19,6	19,8	0,1407	200		-	8,5	13,5	13,7	0,0574			
	560	-	188,5	19,8	20	0,1436	225		-	21	14,4	14,5	0,0680			
600	-	208,5	20,7	21	0,1639	250	-	33,5	15,2	15,4	0,0786					
630	8,5	223,5	21,3	21,6	0,1697	280	-	48,5	16,2	16,4	0,0914					
650	18,5	233,5	21,8	22,1	0,1712	300	-	59	16,8	17	0,0999					
700	43,5	258,5	22,9	23,2	0,1842	315	-	66	17,3	17,5	0,1063					
								355	-	86	18,6	18,8	0,1233			

Sizes in increments of 5 mm can be manufactured on request.

* For designs with BKN a weight of 0.5 kg must be added.

A x B [mm]	Damper blade overlaps		Weight		Free area S _f [m ²]	Spring return actuator	Manual control	A x B [mm]	Damper blade overlaps		Weight		Free area S _f [m ²]	Spring return actuator	Manual control									
	a	c	Man.	Actu.					a	c	Man.	Actu.												
	[mm]	[mm]	[kg]	[kg]*					[mm]	[mm]	[kg]	[kg]*												
450 x	-	108,5	20	20,3	0,1424	BFL	M2	150	-	-	13,1	13,2	0,0455	M2										
	-	133,5	21,6	21,9	0,1636	BFN		180	-	-	14,3	14,5	0,0615		BFL									
	-	158,5	23,2	23,5	0,1849			200	-	8,5	15,2	15,3	0,0722			BF								
	-	183,5	24,7	25,1	0,2061			225	-	21	16,2	16,4	0,0856				M3							
	-	188,5	25	25,4	0,2104			250	-	33,5	17,2	17,4	0,0990					M2						
	-	208,5	26,2	26,6	0,2274			280	-	48,5	18,4	18,6	0,1150						M3					
	8,5	223,5	27,1	27,5	0,2401			300	-	59	19,2	19,4	0,1257							M2				
	18,5	233,5	27,7	28,2	0,2486			315	-	66	19,8	20	0,1338								M3			
	43,5	258,5	29,2	29,7	0,2699			355	-	86	21,4	21,7	0,1552									M2		
	48,5	263,5	29,5	30	0,2741			400	-	108,5	23,1	23,4	0,1792										M3	
	68,5	283,5	30,7	31,2	0,2911			450	-	133,5	25	25,4	0,2060											M2
	93,5	308,5	32,1	32,6	0,3124			500	-	158,5	26,9	27,3	0,2327											
-	-	12,4	12,5	0,0404	550		-	183,5	28,7	29,2	0,2595	M2												
-	-	13,5	13,7	0,0546	560	-	188,5	29,1	29,6	0,2648	M3													
-	8,5	14,3	14,4	0,0641	600	-	208,5	30,6	31,1	0,2862			M2											
-	21	15,2	15,4	0,0760	630	8,5	223,5	31,6	32,2	0,3023				M3										
-	33,5	16,1	16,3	0,0879	650	18,5	233,5	32,3	32,9	0,3130					M2									
-	48,5	17,2	17,4	0,1021	700	43,5	258,5	34,1	34,7	0,3397						M3								
-	59	17,9	18,1	0,1116	710	48,5	263,5	34,4	35	0,3451							M2							
-	66	18,4	18,7	0,1188	750	68,5	283,5	35,8	36,5	0,3665								M3						
-	86	19,9	20,1	0,1378	800	93,5	308,5	37,5	38,2	0,3932									M2					
-	108,5	21,4	21,7	0,1591	150	-	-	13,5	13,7	0,0489										M3				
-	133,5	23,2	23,5	0,1829	180	-	-	14,9	15	0,0661											M2			
-	158,5	24,9	25,2	0,2066	200	-	8,5	15,7	15,9	0,0776												M3		
-	183,5	26,6	27	0,2304	225	-	21	16,8	17	0,0920		M2												
-	188,5	26,9	27,3	0,2351	250	-	33,5	17,9	18,1	0,1064	M3													
-	208,5	28,2	28,7	0,2541	280	-	48,5	19,2	19,4	0,1236			M2											
8,5	223,5	29,2	29,7	0,2684	300	-	59	20	20,3	0,1351				M3										
18,5	233,5	29,9	30,3	0,2779	315	-	66	20,7	21	0,1438					M2									
43,5	258,5	31,5	32	0,3016	355	-	86	22,4	22,7	0,1668						M3								
48,5	263,5	31,8	32,3	0,3064	400	-	108,5	24,2	24,6	0,1926							M2							
68,5	283,5	33	33,6	0,3254	450	-	133,5	26,2	26,6	0,2214								M3						
93,5	308,5	34,6	35,2	0,3491	500	-	158,5	28,2	28,7	0,2501									M2					
-	-	13	13,1	0,0446	550	-	183,5	30,2	30,7	0,2789										M3				
-	-	14,2	14,3	0,0604	560	-	188,5	30,6	31,1	0,2846											M2			
-	8,5	15	15,2	0,0709	600	-	208,5	32,1	32,6	0,3076												M3		
-	21	16	16,2	0,0840	630	8,5	223,5	33,2	33,8	0,3249		M2												
-	33,5	17	17,2	0,0971	650	18,5	233,5	34	34,6	0,3364	M3													
-	48,5	18,2	18,4	0,1129	700	43,5	258,5	35,8	36,5	0,3651			M2											
-	59	19	19,2	0,1234	710	48,5	263,5	36,2	36,8	0,3709				M3										
-	66	19,6	19,8	0,1313	750	68,5	283,5	37,6	38,3	0,3939					M2									
-	86	21,1	21,4	0,1523	800	93,5	308,5	39,4	40,1	0,4226						M3								
-	108,5	22,8	23,2	0,1759	150	-	-	13,9	14	0,0514							M2							
-	133,5	24,7	25,1	0,2021	180	-	-	15,3	15,4	0,0696								M3						
-	158,5	26,6	27	0,2284	200	-	8,5	16,2	16,4	0,0817									M2					
-	183,5	28,4	28,8	0,2546	225	-	21	17,3	17,5	0,0968										M3				
-	188,5	28,7	29,2	0,2599	250	-	33,5	18,4	18,7	0,1119											M2			
-	208,5	30,2	30,7	0,2809	280	-	48,5	19,8	20	0,1301												M3		
8,5	223,5	31,2	31,7	0,2966	300	-	59	20,7	21	0,1422		M2												
18,5	233,5	31,9	32,5	0,3071	315	-	66	21,3	21,6	0,1513	M3													
43,5	258,5	33,7	34,2	0,3334	355	-	86	23,1	23,4	0,1755			M2											
48,5	263,5	34	34,6	0,3386	400	-	108,5	25	25,4	0,2027				M3										
68,5	283,5	35,4	36	0,3596	450	-	133,5	27,1	27,5	0,2329					M2									
93,5	308,5	37	37,7	0,3859	500	-	158,5	29,2	29,7	0,2632						M3								

Sizes in increments of 5 mm can be manufactured on request.

* For designs with BKN a weight of 0.5 kg must be added.

A x B [mm]	Damper blade overlaps		Weight		Free area Sf [m²]	Spring return actuator	Manual control	A x B [mm]	Damper blade overlaps		Weight		Free area Sf [m²]	Spring return actuator	Manual control	
	a [mm]	c [mm]	Man. [kg]	Actu. [kg]*					a [mm]	c [mm]	Man. [kg]	Actu. [kg]*				
630 x	550	-	183,5	31,2	31,7	0,2934	BFN	710 x	225	-	21	18,6	18,8	0,1096	M2	
	560	-	188,5	31,6	32,2	0,2995			250	-	33,5	19,9	20,1	0,1267		
	600	-	208,5	33,2	33,8	0,3237			280	-	48,5	21,4	21,7	0,1473		
	630	8,5	223,5	34,4	35	0,3418	300		-	59	22,4	22,7	0,1610			
	650	18,5	233,5	35,2	35,8	0,3539	315		-	66	23,1	23,4	0,1713			
	700	43,5	258,5	37,1	37,8	0,3842	355		-	86	25	25,4	0,1987			
	710	48,5	263,5	37,5	38,1	0,3902	400		-	108,5	27,2	27,6	0,2295			
	750	68,5	283,5	38,9	39,7	0,4144	450		-	133,5	29,5	30	0,2637			
	800	93,5	308,5	40,8	41,6	0,4447	500		-	158,5	31,8	32,3	0,2980			
650 x	150	-	-	14,1	14,2	0,0531	BFN	550	-	183,5	34	34,6	0,3322	M2		
	180	-	-	15,5	15,7	0,0719		560	-	188,5	34,4	35	0,3391			
	200	-	8,5	16,5	16,7	0,0844		600	-	208,5	36,2	36,8	0,3665			
	225	-	21	17,6	17,9	0,1000		630	8,5	223,5	37,5	38,1	0,3870			
	250	-	33,5	18,8	19	0,1156		650	18,5	233,5	38,3	39	0,4007			
	280	-	48,5	20,2	20,4	0,1344		700	43,5	258,5	40,4	41,1	0,4350			
	300	-	59	21,1	21,4	0,1469		710	48,5	263,5	40,8	41,6	0,4418			
	315	-	66	21,8	22,1	0,1563		750	68,5	283,5	42,4	43,2	0,4692			
	355	-	86	23,6	23,9	0,1813		800	93,5	308,5	44,4	45,3	0,5035			
	400	-	108,5	25,6	25,9	0,2094		BFN	150	-	-	15,2	15,4		0,0616	M2
	450	-	133,5	27,7	28,2	0,2406			180	-	-	16,8	17		0,0834	
	500	-	158,5	29,9	30,3	0,2719			200	-	8,5	17,9	18,1		0,0979	
550	-	183,5	31,9	32,5	0,3031	225	-		21	19,2	19,5	0,1160				
560	-	188,5	32,3	32,9	0,3094	250	-		33,5	20,6	20,8	0,1341				
600	-	208,5	34	34,6	0,3344	280	-		48,5	22,1	22,4	0,1559				
630	8,5	223,5	35,2	35,8	0,3531	300	-		59	23,2	23,5	0,1704				
650	18,5	233,5	36	36,6	0,3656	315	-		66	24	24,3	0,1813				
700	43,5	258,5	37,9	38,6	0,3969	355	-		86	26	26,4	0,2103				
710	48,5	263,5	38,3	39	0,4031	400	-		108,5	28,2	28,7	0,2429				
750	68,5	283,5	39,8	40,6	0,4281	450	-		133,5	30,7	31,2	0,2791				
800	93,5	308,5	41,7	42,5	0,4594	500	-		158,5	33	33,6	0,3154				
700 x	150	-	-	14,6	14,8	0,0574	BFN	550	-	183,5	35,4	36	0,3516	M2		
	180	-	-	16,2	16,4	0,0776		560	-	188,5	35,8	36,5	0,3589			
	200	-	8,5	17,2	17,4	0,0911		600	-	208,5	37,6	38,3	0,3879			
	225	-	21	18,4	18,7	0,1080		630	8,5	223,5	38,9	39,7	0,4096			
	250	-	33,5	19,7	19,9	0,1249		650	18,5	233,5	39,8	40,6	0,4241			
	280	-	48,5	21,2	21,5	0,1451		700	43,5	258,5	42	42,8	0,4604			
	300	-	59	22,1	22,4	0,1586		710	48,5	263,5	42,4	43,2	0,4676			
	315	-	66	22,9	23,2	0,1688		750	68,5	283,5	44,1	45	0,4966			
	355	-	86	24,8	25,1	0,1958		800	93,5	308,5	46,1	47,1	0,5329			
	400	-	108,5	26,9	27,3	0,2261		BFN	150	-	-	15,7	15,9		0,0659	M2
	450	-	133,5	29,2	29,7	0,2599			180	-	-	17,5	17,7		0,0891	
	500	-	158,5	31,5	32	0,2936			200	-	8,5	18,6	18,9		0,1046	
550	-	183,5	33,7	34,2	0,3274	225	-		21	20	20,3	0,1240				
560	-	188,5	34,1	34,7	0,3341	250	-		33,5	21,4	21,7	0,1434				
600	-	208,5	35,8	36,5	0,3611	280	-		48,5	23,1	23,4	0,1666				
630	8,5	223,5	37,1	37,8	0,3814	300	-		59	24,2	24,6	0,1821				
650	18,5	233,5	37,9	38,6	0,3949	315	-		66	25	25,4	0,1938				
700	43,5	258,5	40	40,7	0,4286	355	-		86	27,2	27,6	0,2248				
710	48,5	263,5	40,4	41,1	0,4354	400	-		108,5	29,5	30	0,2596				
750	68,5	283,5	42	42,8	0,4624	450	-		133,5	32,1	32,6	0,2984				
800	93,5	308,5	43,9	44,8	0,4961	500	-		158,5	34,6	35,2	0,3371				
710 x	150	-	-	14,7	14,9	0,0582	BFN	550	-	183,5	37	37,7	0,3759	M2		
	180	-	-	16,3	16,5	0,0788		560	-	188,5	37,5	38,2	0,3836			
	200	-	8,5	17,3	17,5	0,0925		600	-	208,5	39,4	40,1	0,4146			

Sizes in increments of 5 mm can be manufactured on request.

* For designs with BKN a weight of 0.5 kg must be added.

A x B [mm]	Damper blade overlaps		Weight		Free area Sf [m²]	Spring return actuator	Manual control	A x B [mm]	Damper blade overlaps		Weight		Free area Sf [m²]	Spring return actuator	Manual control																																																																																																																																																																																																																																																																																																																																																																																				
	a [mm]	c [mm]	Man. [kg]	Actu. [kg]*					a [mm]	c [mm]	Man. [kg]	Actu. [kg]*																																																																																																																																																																																																																																																																																																																																																																																							
800 x	630	8,5	223,5	40,8	41,6	0,4379	BF	M3	315	-	66	31,2	31,7	0,2688	BFN	M2																																																																																																																																																																																																																																																																																																																																																																																			
	650	18,5	233,5	41,7	42,5	0,4534			700	43,5	258,5	43,9	44,8	0,4921			710	48,5	263,5	44,4	45,3	0,4999	750	68,5	283,5	46,1	47,1	0,5309	800	93,5	308,5	48,2	49,2	0,5696	M4	900 x	150	-	-	16,8	17	0,0744	BFL	M2	1100 x	560	-	188,5	47	47,9	0,5321	BF	M3	180	-	-	18,8	19	0,1006	200	-	8,5	20	20,3	0,1181	225	-	21	21,6	21,9	0,1400	250	-	33,5	23,2	23,5	0,1619	280	-	48,5	25	25,4	0,1881	300	-	59	26,2	26,6	0,2056	315	-	66	27,1	27,5	0,2188	BFN	355	-	86	29,5	30	0,2538	400	-	108,5	32,1	32,6	0,2931	450	-	133,5	34,9	35,5	0,3369	BF	M3	500	-	158,5	37,6	38,3	0,3806	550	-	183,5	40,3	41	0,4244	560	-	188,5	40,8	41,6	0,4331	600	-	208,5	42,8	43,7	0,4681	630	8,5	223,5	44,3	45,2	0,4944	650	18,5	233,5	45,3	46,2	0,5119	700	43,5	258,5	47,7	48,7	0,5556	M4	710	48,5	263,5	48,2	49,2	0,5644	750	68,5	283,5	50	51,1	0,5994	800	93,5	308,5	52,2	53,4	0,6431	150	-	-	17,9	18,1	0,0829	BFL	M2	180	-	-	20	20,3	0,1121	200	-	8,5	21,4	21,7	0,1316	225	-	21	23,2	23,5	0,1560	250	-	33,5	24,9	25,2	0,1804	280	-	48,5	26,9	27,3	0,2096	300	-	59	28,2	28,7	0,2291	315	-	66	29,2	29,7	0,2438	BFN	355	-	86	31,8	32,3	0,2828	400	-	108,5	34,6	35,2	0,3266	450	-	133,5	37,6	38,3	0,3754	BF	M3	500	-	158,5	40,5	41,3	0,4241	550	-	183,5	43,4	44,2	0,4729	560	-	188,5	43,9	44,8	0,4826	600	-	208,5	46,1	47,1	0,5216	630	8,5	223,5	47,7	48,7	0,5509	650	18,5	233,5	48,7	49,8	0,5704	700	43,5	258,5	51,3	52,4	0,6191	M4	710	48,5	263,5	51,7	52,9	0,6289	750	68,5	283,5	53,7	54,9	0,6679	800	93,5	308,5	56	57,3	0,7166	180	-	-	21,3	21,6	0,1236	BFL	M2	200	-	8,5	22,8	23,2	0,1451	225	-	21	24,7	25,1	0,1720	250	-	33,5	26,6	27	0,1989	280	-	48,5	28,7	29,2	0,2311	300	-	59	30,2	30,7	0,2526	BFN																																							
	700	43,5	258,5	43,9	44,8	0,4921			710	48,5	263,5	44,4	45,3	0,4999			750	68,5	283,5	46,1	47,1	0,5309	800	93,5	308,5	48,2	49,2	0,5696	M4	900 x	150	-	-	16,8	17		0,0744	BFL	M2	1100 x	560	-			188,5	47	47,9	0,5321	BF	M3	180			-	-	18,8	19	0,1006	200	-	8,5	20	20,3	0,1181	225	-	21	21,6	21,9	0,1400	250	-	33,5	23,2	23,5	0,1619	280	-	48,5	25	25,4	0,1881	300	-	59	26,2	26,6	0,2056	315	-	66	27,1	27,5	0,2188	BFN		355	-	86	29,5	30	0,2538	400	-	108,5	32,1	32,6	0,2931	450	-	133,5	34,9	35,5	0,3369			BF	M3	500	-	158,5	37,6	38,3	0,3806	550	-	183,5	40,3	41	0,4244	560	-	188,5	40,8	41,6	0,4331	600	-	208,5	42,8	43,7	0,4681	630	8,5	223,5	44,3	45,2	0,4944	650	18,5	233,5	45,3	46,2	0,5119	700	43,5	258,5	47,7		48,7	0,5556	M4	710	48,5	263,5	48,2	49,2	0,5644	750	68,5	283,5	50	51,1	0,5994	800	93,5	308,5	52,2	53,4	0,6431	150	-	-			17,9	18,1	0,0829	BFL	M2	180	-	-	20	20,3	0,1121	200	-	8,5	21,4	21,7	0,1316	225	-	21	23,2	23,5	0,1560	250	-	33,5	24,9	25,2	0,1804	280	-	48,5	26,9	27,3	0,2096	300	-	59	28,2	28,7	0,2291	315		-	66	29,2	29,7	0,2438	BFN	355	-	86	31,8	32,3	0,2828	400	-	108,5	34,6	35,2	0,3266			450	-	133,5	37,6	38,3	0,3754	BF	M3	500	-	158,5	40,5	41,3	0,4241	550	-	183,5	43,4	44,2	0,4729	560	-	188,5	43,9	44,8	0,4826	600	-	208,5	46,1	47,1	0,5216	630	8,5	223,5	47,7	48,7	0,5509	650	18,5	233,5	48,7		49,8	0,5704	700	43,5	258,5	51,3	52,4	0,6191	M4	710	48,5	263,5	51,7	52,9	0,6289	750	68,5	283,5	53,7	54,9	0,6679	800	93,5	308,5			56	57,3	0,7166	180	-	-	21,3	21,6	0,1236	BFL	M2	200	-	8,5	22,8	23,2	0,1451	225	-	21	24,7	25,1	0,1720	250	-	33,5	26,6	27	0,1989	280	-	48,5	28,7	29,2	0,2311	300	-	59	30,2	30,7	0,2526	BFN																												
	710	48,5	263,5	44,4	45,3	0,4999			750	68,5	283,5	46,1	47,1	0,5309			800	93,5	308,5	48,2	49,2	0,5696	M4	900 x	150	-	-	16,8	17		0,0744	BFL	M2	1100 x	560		-			188,5	47	47,9			0,5321	BF	M3	180			-			-	18,8	19	0,1006	200	-	8,5	20	20,3	0,1181	225	-	21	21,6	21,9	0,1400	250	-	33,5	23,2	23,5	0,1619	280	-	48,5	25	25,4	0,1881	300	-	59	26,2	26,6	0,2056	315	-	66	27,1	27,5	0,2188	BFN			355	-	86	29,5	30	0,2538	400	-	108,5	32,1	32,6	0,2931	450	-	133,5	34,9	35,5	0,3369					BF	M3	500	-	158,5	37,6	38,3	0,3806	550	-	183,5	40,3	41	0,4244	560	-	188,5	40,8	41,6	0,4331	600	-	208,5	42,8	43,7	0,4681	630	8,5	223,5	44,3	45,2	0,4944	650	18,5	233,5	45,3	46,2	0,5119	700	43,5		258,5	47,7		48,7	0,5556	M4	710	48,5	263,5	48,2	49,2	0,5644	750	68,5	283,5	50	51,1	0,5994	800	93,5	308,5	52,2	53,4	0,6431			150	-	-			17,9	18,1	0,0829	BFL	M2	180	-	-	20	20,3	0,1121	200	-	8,5	21,4	21,7	0,1316	225	-	21	23,2	23,5	0,1560	250	-	33,5	24,9	25,2	0,1804	280	-	48,5	26,9	27,3	0,2096	300	-		59	28,2	28,7	0,2291	315		-	66	29,2	29,7	0,2438	BFN	355	-	86	31,8	32,3	0,2828			400	-	108,5	34,6	35,2	0,3266			450	-	133,5	37,6	38,3	0,3754	BF	M3	500	-	158,5	40,5	41,3	0,4241	550	-	183,5	43,4	44,2	0,4729	560	-	188,5	43,9	44,8	0,4826	600	-	208,5	46,1	47,1	0,5216	630	8,5		223,5	47,7	48,7	0,5509	650	18,5	233,5	48,7		49,8	0,5704	700	43,5	258,5	51,3	52,4	0,6191	M4	710	48,5	263,5	51,7	52,9	0,6289			750	68,5	283,5	53,7	54,9	0,6679	800	93,5	308,5			56	57,3	0,7166	180	-	-	21,3	21,6	0,1236	BFL	M2	200	-	8,5	22,8	23,2	0,1451	225	-	21	24,7	25,1	0,1720	250	-	33,5	26,6	27	0,1989	280	-	48,5	28,7	29,2	0,2311	300	-	59	30,2	30,7	0,2526	BFN																	
	750	68,5	283,5	46,1	47,1	0,5309			800	93,5	308,5	48,2	49,2	0,5696			M4	900 x	150	-	-	16,8	17		0,0744	BFL	M2	1100 x	560		-			188,5	47		47,9			0,5321	BF	M3			180			-			-			18,8	19	0,1006	200	-	8,5	20	20,3	0,1181	225	-	21	21,6	21,9	0,1400	250	-	33,5	23,2	23,5	0,1619	280	-	48,5	25	25,4	0,1881	300	-	59	26,2	26,6	0,2056	315	-	66	27,1	27,5	0,2188	BFN			355	-	86	29,5	30	0,2538	400	-	108,5	32,1	32,6	0,2931	450	-	133,5	34,9	35,5	0,3369	BF							M3	500	-	158,5	37,6	38,3	0,3806	550	-	183,5	40,3	41	0,4244	560	-	188,5	40,8	41,6	0,4331	600	-	208,5	42,8	43,7	0,4681	630	8,5	223,5	44,3	45,2	0,4944	650	18,5	233,5	45,3	46,2	0,5119	700		43,5	258,5		47,7	48,7		0,5556	M4	710	48,5	263,5	48,2	49,2	0,5644	750	68,5	283,5	50	51,1	0,5994	800	93,5	308,5	52,2			53,4	0,6431	150			-	-	17,9			18,1	0,0829	BFL	M2	180	-	-	20	20,3	0,1121	200	-	8,5	21,4	21,7	0,1316	225	-	21	23,2	23,5	0,1560	250	-	33,5	24,9	25,2	0,1804	280	-	48,5	26,9	27,3	0,2096	300	-	59	28,2		28,7	0,2291	315	-	66		29,2	29,7	0,2438	BFN	355	-			86	31,8	32,3	0,2828	400	-			108,5	34,6	35,2	0,3266	450	-			133,5	37,6	38,3	0,3754	BF	M3	500	-	158,5	40,5	41,3	0,4241	550	-	183,5	43,4	44,2	0,4729	560	-	188,5	43,9	44,8	0,4826	600	-		208,5	46,1	47,1	0,5216	630	8,5	223,5	47,7		48,7	0,5509	650	18,5	233,5	48,7	49,8	0,5704		700	43,5	258,5	51,3	52,4	0,6191			M4	710	48,5	263,5	51,7	52,9	0,6289	750	68,5			283,5	53,7	54,9	0,6679	800	93,5	308,5	56	57,3			0,7166	180	-	-	21,3	21,6	0,1236	BFL	M2	200	-	8,5	22,8	23,2	0,1451	225	-	21	24,7	25,1	0,1720	250	-	33,5	26,6	27	0,1989	280	-	48,5	28,7	29,2	0,2311	300	-	59	30,2	30,7	0,2526	BFN								
	800	93,5	308,5	48,2	49,2	0,5696	M4	900 x	150	-	-	16,8	17	0,0744	BFL	M2	1100 x		560	-	188,5	47	47,9		0,5321			BF	M3		180			-	-		18,8			19					0,1006			200			-			8,5	20	20,3	0,1181	225	-	21	21,6	21,9	0,1400	250	-	33,5	23,2	23,5	0,1619	280	-	48,5	25	25,4	0,1881	300	-	59	26,2	26,6	0,2056	315	-	66	27,1	27,5	0,2188	BFN	355	-	86	29,5			30	0,2538	400	-	108,5	32,1	32,6	0,2931	450	-	133,5	34,9	35,5	0,3369	BF	M3	500	-	158,5									37,6	38,3	0,3806	550	-	183,5	40,3	41	0,4244	560	-	188,5	40,8	41,6	0,4331	600	-	208,5	42,8	43,7	0,4681	630	8,5	223,5	44,3	45,2	0,4944	650	18,5	233,5	45,3	46,2	0,5119	700	43,5	258,5	47,7		48,7	0,5556		M4	710		48,5		263,5	48,2	49,2	0,5644	750	68,5	283,5	50	51,1	0,5994	800	93,5	308,5	52,2	53,4	0,6431			150	-	-			17,9	18,1	0,0829			BFL	M2			180	-	-	20	20,3	0,1121	200	-	8,5	21,4	21,7	0,1316	225	-	21	23,2	23,5	0,1560	250	-	33,5	24,9	25,2	0,1804	280	-	48,5	26,9	27,3	0,2096	300	-	59	28,2	28,7	0,2291	315	-	66	29,2		29,7	0,2438	BFN		355	-			86	31,8	32,3	0,2828	400	-			108,5	34,6	35,2	0,3266	450	-			133,5	37,6	38,3	0,3754			BF	M3	500	-	158,5	40,5	41,3	0,4241	550	-	183,5	43,4	44,2	0,4729	560	-	188,5	43,9	44,8	0,4826		600	-	208,5	46,1	47,1	0,5216	630	8,5		223,5	47,7	48,7	0,5509	650	18,5	233,5	48,7		49,8	0,5704	700	43,5	258,5	51,3				52,4	0,6191	M4	710	48,5	263,5	51,7	52,9			0,6289	750	68,5	283,5	53,7	54,9	0,6679	800	93,5			308,5	56	57,3	0,7166	180	-	-			21,3	21,6	0,1236	BFL	M2	200	-	8,5	22,8	23,2	0,1451	225	-	21	24,7	25,1	0,1720	250	-	33,5	26,6	27	0,1989	280	-	48,5	28,7	29,2	0,2311	300	-	59	30,2	30,7	0,2526	BFN			
900 x	150	-	-	16,8	17	0,0744	BFL		M2	1100 x	560	-	188,5	47			47,9		0,5321	BF	M3																																																																																																																																																																																																																																																																																																																																																																														
	180	-	-	18,8	19	0,1006				200	-	8,5	20	20,3			0,1181		225			-	21		21,6						21,9			0,1400	250		-			33,5					23,2			23,5			0,1619			280	-	48,5	25	25,4	0,1881	300	-	59	26,2	26,6	0,2056	315	-	66	27,1	27,5	0,2188	BFN	355	-	86	29,5	30	0,2538	400	-	108,5	32,1	32,6	0,2931	450	-	133,5		34,9	35,5	0,3369	BF	M3	500	-	158,5	37,6	38,3	0,3806	550	-	183,5	40,3	41	0,4244	560	-	188,5			40,8	41,6	0,4331									600	-	208,5	42,8	43,7	0,4681	630	8,5	223,5	44,3	45,2	0,4944	650	18,5	233,5	45,3	46,2	0,5119	700	43,5	258,5	47,7	48,7	0,5556	M4	710	48,5	263,5	48,2	49,2	0,5644	750	68,5	283,5	50	51,1	0,5994		800	93,5			308,5		52,2		53,4	0,6431	150	-	-	17,9	18,1	0,0829	BFL	M2	180	-	-	20	20,3	0,1121			200	-	8,5			21,4	21,7	0,1316							225	-	21	23,2	23,5	0,1560	250	-	33,5	24,9	25,2	0,1804	280	-	48,5	26,9	27,3	0,2096	300	-	59	28,2	28,7	0,2291	315	-	66	29,2	29,7	0,2438	BFN	355	-	86	31,8	32,3	0,2828	400	-	108,5	34,6	35,2	0,3266		450	-	133,5			37,6	38,3	0,3754	BF	M3	500			-	158,5	40,5	41,3	0,4241	550			-	183,5	43,4	44,2					0,4729	560	-	188,5	43,9	44,8	0,4826	600	-	208,5	46,1	47,1	0,5216	630	8,5	223,5	47,7	48,7		0,5509	650	18,5	233,5	48,7	49,8	0,5704	700		43,5	258,5	51,3	52,4	0,6191	M4	710	48,5		263,5	51,7	52,9	0,6289	750	68,5				283,5	53,7		54,9	0,6679	800	93,5	308,5			56	57,3	0,7166	180	-	-	21,3	21,6	0,1236			BFL	M2	200	-	8,5	22,8	23,2			0,1451	225	-			21	24,7	25,1	0,1720	250	-	33,5	26,6	27	0,1989	280	-	48,5	28,7	29,2	0,2311	300	-	59	30,2	30,7	0,2526	BFN											
	200	-	8,5	20	20,3	0,1181				225	-	21	21,6	21,9			0,1400		250			-	33,5		23,2						23,5			0,1619	280		-			48,5			25	25,4	0,1881			300			-	59	26,2	26,6	0,2056	315	-	66	27,1	27,5	0,2188	BFN	355	-	86	29,5	30	0,2538	400	-	108,5		32,1	32,6	0,2931	450	-	133,5	34,9	35,5	0,3369	BF	M3	500	-	158,5	37,6	38,3	0,3806	550	-			183,5	40,3	41	0,4244	560	-	188,5	40,8	41,6	0,4331	600	-	208,5	42,8	43,7			0,4681	630	8,5		223,5	44,3						45,2	0,4944	650	18,5	233,5	45,3	46,2	0,5119	700	43,5	258,5	47,7	48,7	0,5556	M4	710	48,5	263,5	48,2	49,2	0,5644	750	68,5	283,5		50	51,1	0,5994	800	93,5	308,5	52,2	53,4	0,6431	150	-	-	17,9	18,1	0,0829			BFL		M2		180	-	-	20	20,3	0,1121	200	-			8,5	21,4	21,7	0,1316	225	-	21	23,2	23,5	0,1560	250			-	33,5	24,9							25,2	0,1804	280	-	48,5	26,9	27,3	0,2096	300	-	59	28,2	28,7	0,2291	315	-	66	29,2	29,7	0,2438	BFN	355	-	86	31,8	32,3	0,2828	400	-	108,5		34,6	35,2	0,3266	450	-	133,5	37,6	38,3	0,3754	BF	M3	500	-	158,5	40,5	41,3	0,4241	550	-	183,5	43,4			44,2			0,4729	560	-	188,5	43,9	44,8			0,4826	600	-	208,5					46,1	47,1	0,5216	630	8,5	223,5	47,7	48,7	0,5509	650	18,5	233,5	48,7	49,8	0,5704	700	43,5	258,5	51,3	52,4	0,6191	M4	710	48,5	263,5	51,7	52,9		0,6289	750	68,5	283,5	53,7		54,9	0,6679		800	93,5	308,5	56	57,3	0,7166	180	-		-	21,3		21,6	0,1236	BFL	M2	200			-	8,5	22,8	23,2	0,1451	225	-	21	24,7					25,1	0,1720	250	-	33,5			26,6	27	0,1989			280	-	48,5	28,7	29,2	0,2311	300	-	59	30,2	30,7	0,2526	BFN																					
	225	-	21	21,6	21,9	0,1400				250	-	33,5	23,2	23,5			0,1619		280			-	48,5		25						25,4			0,1881	300		-	59	26,2	26,6			0,2056	315	-			66	27,1	27,5	0,2188	BFN	355	-	86	29,5	30	0,2538	400	-	108,5		32,1	32,6	0,2931	450	-	133,5	34,9	35,5	0,3369		BF	M3	500	-	158,5	37,6	38,3	0,3806	550			-	183,5	40,3	41	0,4244	560	-	188,5			40,8	41,6	0,4331	600	-	208,5	42,8	43,7	0,4681	630	8,5	223,5	44,3	45,2	0,4944			650	18,5	233,5		45,3	46,2	0,5119	700				43,5	258,5	47,7	48,7	0,5556	M4	710	48,5	263,5	48,2	49,2	0,5644	750	68,5		283,5	50	51,1	0,5994	800	93,5	308,5	52,2	53,4		0,6431	150	-	-	17,9	18,1	0,0829	BFL	M2	180	-	-	20	20,3	0,1121	200						-	8,5	21,4	21,7	0,1316	225	-	21			23,2	23,5	0,1560	250	-	33,5	24,9	25,2	0,1804	280	-	48,5	26,9	27,3	0,2096	300							-	59	28,2	28,7	0,2291	315	-	66	29,2	29,7	0,2438	BFN	355	-	86	31,8	32,3	0,2828	400	-		108,5	34,6	35,2	0,3266	450	-	133,5	37,6	38,3		0,3754	BF	M3	500	-	158,5	40,5	41,3	0,4241			550	-	183,5	43,4	44,2	0,4729	560	-	188,5	43,9			44,8	0,4826	600	-	208,5	46,1	47,1	0,5216	630			8,5	223,5	47,7	48,7					0,5509	650	18,5	233,5	48,7	49,8	0,5704	700	43,5	258,5	51,3	52,4	0,6191	M4	710	48,5	263,5	51,7	52,9	0,6289	750		68,5	283,5	53,7	54,9	0,6679	800	93,5	308,5	56	57,3	0,7166		180	-		-	21,3	21,6	0,1236	BFL	M2	200	-		8,5	22,8		23,2	0,1451			225	-	21	24,7	25,1	0,1720	250	-	33,5	26,6	27	0,1989					280	-	48,5	28,7	29,2			0,2311	300	-			59	30,2	30,7	0,2526	BFN																													
	250	-	33,5	23,2	23,5	0,1619				280	-	48,5	25	25,4			0,1881		300			-	59		26,2						26,6	0,2056	315	-	66		27,1	27,5	0,2188	BFN			355	-	86	29,5	30	0,2538	400	-	108,5		32,1	32,6	0,2931	450	-	133,5	34,9	35,5	0,3369		BF	M3	500	-	158,5	37,6	38,3	0,3806	550	-			183,5	40,3	41	0,4244	560	-	188,5			40,8	41,6	0,4331	600	-	208,5	42,8	43,7			0,4681	630	8,5	223,5	44,3	45,2	0,4944	650	18,5	233,5	45,3	46,2	0,5119	700	43,5			258,5	47,7	48,7		0,5556	M4	710	48,5	263,5	48,2		49,2	0,5644	750	68,5	283,5		50	51,1	0,5994	800	93,5	308,5	52,2	53,4		0,6431	150	-	-	17,9	18,1	0,0829	BFL	M2		180	-	-	20	20,3	0,1121	200			-	8,5	21,4	21,7	0,1316	225	-			21			23,2	23,5	0,1560	250	-	33,5	24,9	25,2			0,1804	280	-	48,5	26,9	27,3	0,2096	300	-	59	28,2	28,7	0,2291	315	-	66	29,2	29,7					0,2438	BFN	355	-	86	31,8	32,3	0,2828	400	-	108,5		34,6	35,2	0,3266	450	-	133,5	37,6	38,3		0,3754	BF	M3	500	-	158,5	40,5	41,3	0,4241	550	-			183,5	43,4	44,2	0,4729	560	-			188,5	43,9	44,8	0,4826	600	-	208,5	46,1	47,1	0,5216			630	8,5	223,5	47,7	48,7	0,5509	650	18,5	233,5	48,7	49,8	0,5704	700	43,5	258,5					51,3	52,4	0,6191	M4	710	48,5	263,5	51,7	52,9	0,6289	750	68,5	283,5		53,7	54,9	0,6679	800	93,5	308,5	56		57,3	0,7166	180	-	-	21,3	21,6	0,1236	BFL	M2	200		-	8,5	22,8	23,2	0,1451	225	-			21	24,7		25,1	0,1720		250	-			33,5	26,6	27	0,1989	280	-	48,5	28,7	29,2	0,2311	300	-	59	30,2			30,7	0,2526	BFN																																											
	280	-	48,5	25	25,4	0,1881				300	-	59	26,2	26,6			0,2056		315			-	66		27,1	27,5	0,2188				BFN	355	-	86	29,5		30	0,2538	400		-	108,5	32,1	32,6	0,2931	450	-	133,5	34,9	35,5	0,3369		BF	M3	500	-	158,5	37,6	38,3	0,3806	550	-			183,5	40,3	41	0,4244	560	-	188,5	40,8			41,6	0,4331	600	-	208,5	42,8	43,7			0,4681	630	8,5	223,5	44,3	45,2	0,4944	650			18,5	233,5	45,3	46,2	0,5119	700	43,5	258,5	47,7	48,7	0,5556	M4	710	48,5	263,5			48,2	49,2	0,5644	750	68,5		283,5	50	51,1	0,5994	800	93,5	308,5	52,2	53,4	0,6431		150	-	-	17,9	18,1	0,0829	BFL	M2		180	-	-	20	20,3	0,1121	200				-	8,5	21,4	21,7	0,1316	225	-			21	23,2	23,5	0,1560	250	-	33,5			24,9		25,2	0,1804	280	-	48,5	26,9	27,3	0,2096	300			-	59	28,2	28,7	0,2291	315	-	66	29,2	29,7	0,2438	BFN	355	-	86	31,8	32,3	0,2828			400	-	108,5		34,6	35,2	0,3266	450	-	133,5	37,6	38,3	0,3754		BF	M3	500	-	158,5	40,5	41,3	0,4241	550	-			183,5	43,4	44,2	0,4729	560	-	188,5	43,9			44,8	0,4826	600	-	208,5	46,1			47,1	0,5216	630	8,5	223,5	47,7	48,7	0,5509	650	18,5			233,5	48,7	49,8	0,5704	700	43,5	258,5	51,3	52,4	0,6191	M4	710	48,5	263,5	51,7	52,9	0,6289			750	68,5	283,5		53,7	54,9	0,6679	800	93,5	308,5	56	57,3	0,7166		180	-	-	21,3	21,6	0,1236	BFL		M2	200	-	8,5	22,8	23,2	0,1451	225			-		21	24,7	25,1	0,1720	250	-	33,5			26,6	27	0,1989	280	-		48,5	28,7			29,2	0,2311	300	-	59	30,2	30,7	0,2526	BFN																																																					
	300	-	59	26,2	26,6	0,2056				315	-	66	27,1	27,5	0,2188	BFN	355		-			86	29,5		30	0,2538	400	-	108,5			32,1	32,6	0,2931	450		-	133,5	34,9		35,5	0,3369	BF	M3	500	-	158,5	37,6	38,3	0,3806	550	-			183,5	40,3	41	0,4244	560	-	188,5	40,8			41,6	0,4331	600	-	208,5	42,8	43,7	0,4681			630	8,5	223,5	44,3	45,2	0,4944	650			18,5	233,5	45,3	46,2	0,5119	700	43,5	258,5			47,7	48,7	0,5556	M4	710	48,5	263,5	48,2	49,2	0,5644	750		68,5	283,5	50	51,1	0,5994	800	93,5	308,5	52,2	53,4		0,6431	150	-	-	17,9	18,1	0,0829	BFL	M2	180		-	-	20	20,3	0,1121	200				-	8,5	21,4	21,7	0,1316	225	-				21	23,2	23,5	0,1560	250	-	33,5			24,9	25,2	0,1804	280	-	48,5	26,9	27,3		0,2096		300	-	59	28,2	28,7	0,2291	315	-	66			29,2	29,7	0,2438	BFN	355	-	86	31,8	32,3	0,2828	400		-	108,5	34,6	35,2	0,3266	450	-	133,5	37,6	38,3	0,3754		BF	M3	500	-	158,5	40,5	41,3	0,4241	550	-			183,5	43,4	44,2	0,4729	560	-	188,5	43,9			44,8	0,4826	600	-	208,5	46,1	47,1	0,5216			630	8,5	223,5	47,7	48,7	0,5509			650	18,5	233,5	48,7	49,8	0,5704	700	43,5	258,5	51,3			52,4	0,6191	M4	710	48,5	263,5	51,7	52,9	0,6289	750		68,5	283,5	53,7	54,9	0,6679	800	93,5	308,5	56	57,3	0,7166		180	-	-	21,3	21,6	0,1236	BFL	M2	200		-	8,5	22,8	23,2	0,1451	225				-	21	24,7	25,1	0,1720	250	-			33,5		26,6	27	0,1989	280	-	48,5	28,7			29,2	0,2311	300	-	59	30,2	30,7	0,2526			BFN																																																													
	315	-	66	27,1	27,5	0,2188	BFN		355	-	86	29,5	30	0,2538	400		-		108,5	32,1	32,6	0,2931	450		-	133,5	34,9	35,5	0,3369			BF	M3	500	-		158,5	37,6	38,3	0,3806	550	-			183,5	40,3	41	0,4244	560	-	188,5	40,8			41,6	0,4331	600	-	208,5	42,8	43,7	0,4681			630	8,5	223,5	44,3	45,2	0,4944	650	18,5			233,5	45,3	46,2	0,5119	700	43,5	258,5			47,7	48,7	0,5556	M4	710	48,5	263,5	48,2			49,2	0,5644	750		68,5	283,5	50	51,1	0,5994	800	93,5		308,5	52,2	53,4	0,6431	150	-	-	17,9	18,1	0,0829		BFL	M2	180	-	-	20	20,3			0,1121		200	-	8,5	21,4	21,7	0,1316				225	-	21	23,2	23,5	0,1560	250				-	33,5	24,9	25,2	0,1804	280	-			48,5	26,9	27,3	0,2096	300	-	59	28,2		28,7		0,2291	315	-	66	29,2	29,7	0,2438	BFN	355			-	86	31,8		32,3	0,2828	400	-	108,5	34,6	35,2		0,3266	450	-	133,5	37,6	38,3	0,3754	BF	M3	500	-	158,5			40,5	41,3	0,4241	550	-	183,5	43,4	44,2			0,4729	560	-	188,5	43,9	44,8	0,4826	600			-	208,5	46,1	47,1	0,5216	630	8,5	223,5			47,7	48,7	0,5509	650	18,5	233,5			48,7	49,8	0,5704	700	43,5	258,5	51,3	52,4	0,6191	M4			710	48,5		263,5	51,7	52,9	0,6289	750	68,5	283,5		53,7	54,9	0,6679	800	93,5	308,5	56	57,3	0,7166	180	-		-	21,3	21,6	0,1236	BFL	M2			200		-	8,5	22,8	23,2	0,1451	225				-	21	24,7	25,1	0,1720	250	-			33,5		26,6	27	0,1989	280	-	48,5	28,7			29,2	0,2311	300	-	59	30,2	30,7	0,2526			BFN																																																													
	355	-	86	29,5	30	0,2538			400	-	108,5	32,1	32,6	0,2931	450		-		133,5	34,9	35,5	0,3369	BF		M3	500	-	158,5	37,6		38,3			0,3806	550		-	183,5	40,3	41	0,4244	560			-	188,5	40,8	41,6	0,4331	600	-	208,5			42,8	43,7	0,4681	630	8,5	223,5	44,3	45,2			0,4944	650	18,5	233,5	45,3	46,2	0,5119	700			43,5	258,5	47,7	48,7	0,5556	M4	710			48,5	263,5	48,2		49,2	0,5644	750	68,5	283,5	50	51,1	0,5994	800		93,5	308,5	52,2	53,4	0,6431	150	-		-	17,9	18,1	0,0829	BFL	M2	180	-	-	20				20,3	0,1121	200	-	8,5			21,4		21,7	0,1316	225	-	21	23,2				23,5	0,1560	250	-	33,5	24,9	25,2			0,1804	280	-	48,5	26,9	27,3	0,2096	300			-	59	28,2	28,7	0,2291	315	-	66		29,2		29,7	0,2438	BFN	355	-	86	31,8		32,3	0,2828	400	-	108,5	34,6		35,2	0,3266	450	-	133,5	37,6	38,3	0,3754	BF	M3	500	-	158,5	40,5	41,3			0,4241	550	-			183,5	43,4	44,2	0,4729	560	-	188,5	43,9			44,8	0,4826	600	-	208,5	46,1	47,1	0,5216			630	8,5	223,5	47,7	48,7	0,5509	650	18,5			233,5	48,7	49,8	0,5704	700	43,5			258,5	51,3	52,4	0,6191	M4	710	48,5	263,5	51,7		52,9	0,6289	750	68,5		283,5	53,7	54,9	0,6679	800	93,5	308,5		56	57,3	0,7166	180	-	-	21,3	21,6	0,1236	BFL	M2		200	-	8,5	22,8					23,2		0,1451	225	-	21	24,7	25,1				0,1720	250	-	33,5	26,6	27	0,1989			280	-	48,5	28,7	29,2	0,2311	300	-	59			30,2	30,7	0,2526	BFN																																																																				
	400	-	108,5	32,1	32,6	0,2931			450	-	133,5	34,9	35,5	0,3369	BF	M3	500		-	158,5	37,6	38,3				0,3806	550	-	183,5		40,3			41	0,4244	560	-	188,5	40,8	41,6	0,4331	600			-	208,5	42,8	43,7	0,4681	630	8,5	223,5			44,3	45,2	0,4944	650	18,5	233,5	45,3	46,2			0,5119	700	43,5	258,5	47,7	48,7	0,5556	M4			710	48,5	263,5	48,2	49,2		0,5644	750	68,5	283,5	50	51,1		0,5994	800	93,5	308,5	52,2	53,4	0,6431	150	-		-	17,9	18,1	0,0829	BFL	M2	180		-	-	20	20,3			0,1121	200	-	8,5				21,4	21,7	0,1316	225	-			21		23,2	23,5	0,1560	250	-	33,5			24,9	25,2	0,1804	280	-	48,5	26,9	27,3			0,2096	300	-	59	28,2	28,7	0,2291	315			-	66	29,2	29,7	0,2438	BFN	355	-	86	31,8	32,3	0,2828	400		-	108,5	34,6	35,2		0,3266	450	-	133,5	37,6	38,3	0,3754	BF	M3	500	-	158,5	40,5	41,3	0,4241			550	-	183,5	43,4	44,2			0,4729	560	-			188,5	43,9	44,8	0,4826	600	-	208,5	46,1			47,1	0,5216	630	8,5	223,5	47,7	48,7	0,5509			650	18,5	233,5	48,7	49,8	0,5704	700	43,5			258,5	51,3	52,4	0,6191	M4	710	48,5	263,5	51,7	52,9	0,6289	750		68,5	283,5	53,7	54,9		0,6679	800	93,5	308,5		56	57,3	0,7166	180	-	-	21,3		21,6	0,1236	BFL	M2	200	-	8,5	22,8	23,2				0,1451	225	-	21					24,7		25,1	0,1720	250	-	33,5	26,6		27		0,1989	280	-	48,5	28,7	29,2	0,2311			300	-	59	30,2	30,7	0,2526	BFN																																																																												
	450	-	133,5	34,9	35,5	0,3369	BF		M3	500	-	158,5	37,6	38,3			0,3806		550	-	183,5	40,3				41	0,4244	560	-	188,5	40,8			41,6	0,4331	600	-	208,5	42,8	43,7	0,4681	630			8,5	223,5	44,3	45,2	0,4944	650	18,5	233,5			45,3	46,2	0,5119	700	43,5	258,5	47,7	48,7			0,5556	M4	710	48,5	263,5	48,2	49,2		0,5644	750	68,5	283,5	50	51,1	0,5994		800	93,5	308,5	52,2	53,4	0,6431		150	-	-	17,9	18,1	0,0829	BFL	M2	180		-	-	20	20,3			0,1121		200	-	8,5	21,4			21,7	0,1316	225	-				21	23,2	23,5	0,1560	250			-	33,5	24,9	25,2	0,1804	280	-	48,5			26,9	27,3	0,2096	300	-	59	28,2	28,7			0,2291	315	-	66	29,2	29,7	0,2438	BFN	355	-	86	31,8	32,3	0,2828	400		-	108,5	34,6	35,2	0,3266	450	-		133,5	37,6	38,3	0,3754	BF	M3	500	-	158,5	40,5	41,3	0,4241			550	-	183,5	43,4	44,2	0,4729			560	-	188,5	43,9	44,8			0,4826	600	-			208,5	46,1	47,1	0,5216	630	8,5	223,5	47,7			48,7	0,5509	650	18,5	233,5	48,7	49,8	0,5704			700	43,5	258,5	51,3	52,4	0,6191	M4	710	48,5	263,5	51,7	52,9	0,6289	750		68,5	283,5	53,7	54,9	0,6679	800	93,5		308,5	56	57,3	0,7166		180	-	-	21,3		21,6	0,1236	BFL	M2	200	-	8,5		22,8	23,2			0,1451	225	-	21	24,7				25,1	0,1720	250	-					33,5	26,6	27	0,1989	280	-	48,5	28,7		29,2		0,2311	300	-	59	30,2	30,7	0,2526			BFN																																																																																		
	500	-	158,5	37,6	38,3	0,3806				550	-	183,5	40,3	41			0,4244		560	-	188,5	40,8		41,6		0,4331	600	-	208,5	42,8	43,7			0,4681	630	8,5	223,5	44,3	45,2	0,4944	650	18,5			233,5	45,3	46,2	0,5119	700	43,5	258,5	47,7			48,7	0,5556	M4	710	48,5	263,5	48,2	49,2	0,5644	750	68,5		283,5	50	51,1	0,5994	800		93,5	308,5	52,2	53,4	0,6431	150	-		-	17,9	18,1	0,0829	BFL	M2		180	-	-	20	20,3	0,1121			200		-	8,5	21,4	21,7			0,1316		225	-	21	23,2			23,5	0,1560	250	-	33,5			24,9	25,2	0,1804	280	-			48,5	26,9	27,3	0,2096	300	-	59	28,2			28,7	0,2291	315	-	66	29,2	29,7	0,2438	BFN	355	-	86	31,8	32,3	0,2828	400	-		108,5	34,6	35,2	0,3266	450	-	133,5		37,6	38,3	0,3754	BF	M3	500	-	158,5	40,5	41,3	0,4241	550			-	183,5	43,4	44,2	0,4729	560			-	188,5	43,9	44,8	0,4826	600			-	208,5	46,1	47,1	0,5216			630	8,5	223,5			47,7	48,7	0,5509	650	18,5	233,5	48,7	49,8			0,5704	700	43,5	258,5	51,3	52,4	0,6191	M4	710	48,5	263,5	51,7	52,9	0,6289	750	68,5		283,5	53,7	54,9	0,6679	800	93,5	308,5		56	57,3	0,7166	180	-	-	21,3		21,6	0,1236	BFL	M2		200	-	8,5	22,8		23,2	0,1451			225	-	21		24,7	25,1			0,1720	250	-	33,5	26,6			27	0,1989	280	-	48,5					28,7	29,2	0,2311	300	-	59	30,2	30,7		0,2526		BFN																																																																																											
	550	-	183,5	40,3	41	0,4244				560	-	188,5	40,8	41,6			0,4331	600	-	208,5	42,8	43,7		0,4681		630	8,5	223,5	44,3	45,2	0,4944			650	18,5	233,5	45,3	46,2	0,5119	700	43,5	258,5			47,7	48,7	0,5556	M4	710	48,5	263,5	48,2	49,2	0,5644	750	68,5		283,5	50	51,1	0,5994	800	93,5	308,5	52,2		53,4	0,6431	150	-	-		17,9	18,1	0,0829	BFL	M2	180	-		-	20	20,3	0,1121				200	-	8,5	21,4	21,7	0,1316			225		-	21	23,2	23,5			0,1560	250	-	33,5	24,9	25,2			0,1804	280	-	48,5	26,9			27,3	0,2096	300	-	59			28,2	28,7	0,2291	315	-	66	29,2	29,7	0,2438	BFN	355	-	86	31,8	32,3	0,2828	400	-		108,5	34,6	35,2	0,3266	450	-	133,5	37,6		38,3	0,3754	BF	M3	500	-	158,5	40,5	41,3	0,4241	550			-	183,5	43,4	44,2	0,4729	560	-			188,5	43,9	44,8	0,4826	600	-			208,5	46,1	47,1	0,5216	630	8,5			223,5	47,7	48,7	0,5509	650			18,5	233,5	48,7			49,8	0,5704	700	43,5	258,5	51,3	52,4	0,6191	M4	710	48,5	263,5	51,7	52,9	0,6289	750	68,5		283,5	53,7	54,9	0,6679	800	93,5	308,5	56		57,3	0,7166	180	-	-	21,3	21,6		0,1236	BFL	M2	200	-	8,5	22,8		23,2	0,1451				225	-	21	24,7		25,1	0,1720			250	-	33,5	26,6	27	0,1989			280	-	48,5	28,7	29,2			0,2311	300	-	59	30,2					30,7	0,2526	BFN																																																																																																				
	560	-	188,5	40,8	41,6	0,4331		600		-	208,5	42,8	43,7	0,4681			630	8,5	223,5	44,3	45,2	0,4944		650		18,5	233,5	45,3	46,2	0,5119	700			43,5	258,5	47,7	48,7	0,5556	M4	710	48,5	263,5	48,2	49,2	0,5644	750	68,5		283,5	50	51,1	0,5994	800	93,5	308,5	52,2		53,4	0,6431	150	-	-	17,9	18,1	0,0829		BFL	M2	180	-	-		20	20,3	0,1121			200	-		8,5	21,4	21,7	0,1316				225	-	21	23,2	23,5	0,1560			250	-	33,5	24,9	25,2	0,1804			280	-	48,5	26,9	27,3	0,2096			300	-	59	28,2	28,7			0,2291	315	-	66	29,2	29,7	0,2438	BFN	355	-	86	31,8	32,3	0,2828	400	-		108,5	34,6	35,2	0,3266	450	-	133,5	37,6		38,3	0,3754	BF	M3	500	-	158,5	40,5	41,3	0,4241	550			-	183,5	43,4	44,2	0,4729	560	-			188,5	43,9	44,8	0,4826	600	-	208,5			46,1	47,1	0,5216	630	8,5	223,5			47,7	48,7	0,5509	650	18,5	233,5			48,7	49,8	0,5704	700	43,5			258,5	51,3	52,4	0,6191	M4	710	48,5	263,5	51,7	52,9	0,6289	750	68,5		283,5	53,7	54,9	0,6679	800	93,5	308,5	56		57,3	0,7166	180	-	-	21,3	21,6	0,1236		BFL	M2	200	-	8,5	22,8	23,2		0,1451			225	-	21	24,7		25,1	0,1720				250	-	33,5	26,6	27	0,1989	280			-	48,5	28,7	29,2	0,2311	300			-	59	30,2	30,7	0,2526			BFN																																																																																																															
600	-	208,5	42,8	43,7	0,4681	630		8,5		223,5	44,3	45,2	0,4944	650			18,5	233,5	45,3	46,2	0,5119	700		43,5		258,5	47,7	48,7	0,5556	M4	710	48,5	263,5	48,2	49,2	0,5644	750	68,5		283,5	50	51,1	0,5994	800	93,5	308,5	52,2		53,4	0,6431	150	-	-	17,9	18,1	0,0829		BFL	M2	180	-	-	20	20,3	0,1121				200	-	8,5		21,4	21,7	0,1316			225	-		21	23,2	23,5	0,1560			250	-	33,5	24,9	25,2	0,1804	280			-	48,5	26,9	27,3	0,2096	300			-	59	28,2	28,7	0,2291	315			-	66	29,2	29,7	0,2438	BFN	355	-	86	31,8	32,3	0,2828	400	-		108,5	34,6	35,2	0,3266	450	-	133,5	37,6		38,3	0,3754	BF	M3	500	-	158,5	40,5	41,3	0,4241	550			-	183,5	43,4	44,2	0,4729	560	-			188,5	43,9	44,8	0,4826	600	-	208,5			46,1	47,1	0,5216	630	8,5	223,5	47,7			48,7	0,5509	650	18,5	233,5	48,7			49,8	0,5704	700	43,5	258,5	51,3			52,4	0,6191	M4	710	48,5	263,5	51,7	52,9	0,6289	750	68,5		283,5	53,7	54,9	0,6679	800	93,5	308,5	56		57,3	0,7166	180	-	-	21,3	21,6	0,1236		BFL	M2	200	-	8,5	22,8	23,2	0,1451				225	-	21	24,7	25,1		0,1720			250	-	33,5	26,6		27	0,1989			280	-	48,5	28,7	29,2	0,2311	300	-			59	30,2	30,7	0,2526	BFN																																																																																																																										
630	8,5	223,5	44,3	45,2	0,4944	650		18,5		233,5	45,3	46,2	0,5119	700			43,5	258,5	47,7	48,7	0,5556	M4	710	48,5	263,5	48,2	49,2	0,5644	750		68,5	283,5	50	51,1	0,5994	800	93,5	308,5		52,2	53,4	0,6431	150	-	-	17,9	18,1		0,0829	BFL	M2	180	-	-	20	20,3				0,1121	200	-	8,5	21,4	21,7				0,1316	225	-		21	23,2	23,5			0,1560	250	-	33,5	24,9	25,2	0,1804			280	-	48,5	26,9	27,3	0,2096	300			-	59	28,2	28,7	0,2291	315			-	66	29,2	29,7	0,2438	BFN	355	-	86	31,8	32,3	0,2828	400		-	108,5	34,6	35,2	0,3266	450	-	133,5		37,6	38,3	0,3754	BF	M3	500	-	158,5	40,5	41,3	0,4241			550	-	183,5	43,4	44,2	0,4729	560			-	188,5	43,9	44,8	0,4826	600	-			208,5	46,1	47,1	0,5216	630	8,5	223,5			47,7	48,7	0,5509	650	18,5	233,5	48,7			49,8	0,5704	700	43,5	258,5	51,3			52,4	0,6191	M4	710	48,5	263,5	51,7	52,9	0,6289	750		68,5	283,5	53,7	54,9	0,6679	800	93,5	308,5		56	57,3	0,7166	180	-	-	21,3	21,6		0,1236	BFL	M2	200	-	8,5	22,8	23,2				0,1451	225	-	21	24,7	25,1				0,1720	250	-	33,5	26,6		27			0,1989	280	-	48,5	28,7	29,2	0,2311			300	-	59	30,2	30,7	0,2526	BFN																																																																																																																																		
650	18,5	233,5	45,3	46,2	0,5119	700		43,5		258,5	47,7	48,7	0,5556	M4	710	48,5	263,5	48,2	49,2	0,5644	750		68,5	283,5	50	51,1	0,5994	800	93,5		308,5	52,2	53,4	0,6431	150	-	-	17,9		18,1	0,0829	BFL	M2	180	-	-	20		20,3			0,1121	200	-	8,5	21,4				21,7	0,1316	225	-	21	23,2				23,5	0,1560	250	-	33,5	24,9	25,2			0,1804	280	-	48,5	26,9	27,3	0,2096			300	-	59	28,2	28,7	0,2291	315			-	66	29,2	29,7	0,2438	BFN	355	-	86	31,8	32,3	0,2828	400		-	108,5	34,6	35,2	0,3266	450	-		133,5	37,6	38,3	0,3754	BF	M3	500	-	158,5	40,5	41,3	0,4241			550	-	183,5	43,4	44,2	0,4729			560	-	188,5	43,9	44,8	0,4826	600			-	208,5	46,1	47,1	0,5216	630	8,5			223,5	47,7	48,7	0,5509	650	18,5	233,5			48,7	49,8	0,5704	700	43,5	258,5	51,3			52,4	0,6191	M4	710	48,5	263,5	51,7	52,9	0,6289	750		68,5	283,5	53,7	54,9	0,6679	800	93,5		308,5	56	57,3	0,7166	180	-	-	21,3		21,6	0,1236	BFL	M2	200	-	8,5	22,8		23,2			0,1451	225	-	21	24,7				25,1	0,1720	250	-	33,5	26,6				27	0,1989	280	-	48,5	28,7	29,2			0,2311	300	-	59	30,2	30,7	0,2526			BFN																																																																																																																																								
700	43,5	258,5	47,7	48,7	0,5556	M4	710	48,5	263,5	48,2	49,2	0,5644	750		68,5	283,5	50	51,1	0,5994	800	93,5		308,5	52,2	53,4	0,6431	150	-	-		17,9	18,1	0,0829	BFL	M2	180	-	-		20	20,3			0,1121	200	-	8,5		21,4			21,7	0,1316	225	-	21				23,2	23,5	0,1560	250	-	33,5	24,9			25,2	0,1804	280	-	48,5	26,9	27,3			0,2096	300	-	59	28,2	28,7	0,2291			315	-	66	29,2	29,7	0,2438	BFN	355	-	86	31,8	32,3	0,2828	400		-	108,5	34,6	35,2	0,3266	450	-		133,5	37,6	38,3	0,3754	BF	M3	500	-	158,5	40,5	41,3	0,4241			550	-	183,5	43,4	44,2	0,4729			560	-	188,5	43,9	44,8	0,4826			600	-	208,5	46,1	47,1	0,5216	630			8,5	223,5	47,7	48,7	0,5509	650	18,5			233,5	48,7	49,8	0,5704	700	43,5	258,5			51,3	52,4	0,6191	M4	710	48,5	263,5	51,7	52,9	0,6289	750		68,5	283,5	53,7	54,9	0,6679	800	93,5		308,5	56	57,3	0,7166	180	-	-		21,3	21,6	0,1236	BFL	M2	200	-	8,5		22,8	23,2			0,1451	225	-	21		24,7			25,1	0,1720	250	-	33,5				26,6	27	0,1989	280	-	48,5	28,7			29,2	0,2311	300	-	59	30,2	30,7			0,2526	BFN																																																																																																																																																
710	48,5	263,5	48,2	49,2	0,5644		750	68,5	283,5	50	51,1	0,5994	800		93,5	308,5	52,2	53,4	0,6431	150	-		-	17,9	18,1	0,0829	BFL	M2	180		-	-	20			20,3	0,1121	200		-	8,5			21,4	21,7	0,1316	225		-			21	23,2	23,5	0,1560	250	-			33,5	24,9	25,2	0,1804	280	-	48,5			26,9	27,3	0,2096	300	-	59	28,2			28,7	0,2291	315	-	66	29,2	29,7	0,2438	BFN	355	-	86	31,8	32,3	0,2828		400	-	108,5	34,6	35,2	0,3266	450		-	133,5	37,6	38,3	0,3754	BF	M3	500	-	158,5	40,5	41,3			0,4241	550	-	183,5	43,4	44,2			0,4729	560	-	188,5	43,9	44,8			0,4826	600	-	208,5	46,1	47,1			0,5216	630	8,5	223,5	47,7	48,7	0,5509			650	18,5	233,5	48,7	49,8	0,5704	700			43,5	258,5	51,3	52,4	0,6191	M4	710	48,5	263,5	51,7	52,9	0,6289		750	68,5	283,5	53,7	54,9	0,6679	800		93,5	308,5	56	57,3	0,7166	180	-		-	21,3	21,6	0,1236	BFL	M2	200		-	8,5	22,8			23,2	0,1451	225		-	21			24,7	25,1	0,1720	250		-			33,5	26,6	27	0,1989	280	-			48,5	28,7	29,2	0,2311	300	-	59			30,2	30,7	0,2526	BFN																																																																																																																																																							
750	68,5	283,5	50	51,1	0,5994		800	93,5	308,5	52,2	53,4	0,6431	150		-	-	17,9	18,1	0,0829	BFL	M2		180	-	-	20			20,3		0,1121	200	-			8,5	21,4	21,7		0,1316	225			-	21	23,2	23,5	0,1560	250			-	33,5	24,9	25,2	0,1804	280			-	48,5	26,9	27,3	0,2096	300	-			59	28,2	28,7	0,2291	315	-	66	29,2	29,7	0,2438	BFN	355	-	86	31,8	32,3	0,2828		400	-	108,5	34,6	35,2	0,3266		450	-	133,5	37,6	38,3	0,3754	BF	M3	500	-	158,5	40,5	41,3			0,4241	550	-	183,5	43,4			44,2	0,4729	560	-	188,5	43,9			44,8	0,4826	600	-	208,5	46,1			47,1	0,5216	630	8,5	223,5	47,7			48,7	0,5509	650	18,5	233,5	48,7	49,8			0,5704	700	43,5	258,5	51,3	52,4	0,6191	M4	710	48,5	263,5	51,7	52,9	0,6289		750	68,5	283,5	53,7	54,9	0,6679		800	93,5	308,5	56	57,3	0,7166	180		-	-	21,3	21,6	0,1236	BFL	M2		200	-	8,5	22,8			23,2		0,1451	225	-			21	24,7	25,1		0,1720	250			-	33,5	26,6	27	0,1989	280			-	48,5	28,7	29,2	0,2311	300			-	59	30,2	30,7	0,2526	BFN																																																																																																																																																														
800	93,5	308,5	52,2	53,4	0,6431		150	-	-	17,9	18,1	0,0829	BFL		M2	180	-	-	20				20,3	0,1121	200	-			8,5		21,4	21,7	0,1316			225	-	21	23,2	23,5	0,1560			250	-	33,5	24,9	25,2	0,1804			280	-	48,5	26,9	27,3	0,2096			300	-	59	28,2	28,7	0,2291	315	-	66	29,2	29,7	0,2438	BFN	355	-	86	31,8	32,3	0,2828		400	-	108,5	34,6	35,2	0,3266		450	-	133,5	37,6	38,3	0,3754	BF	M3	500	-	158,5	40,5	41,3			0,4241	550	-	183,5	43,4			44,2	0,4729	560	-	188,5			43,9	44,8	0,4826	600	-	208,5			46,1	47,1	0,5216	630	8,5	223,5			47,7	48,7	0,5509	650	18,5	233,5			48,7	49,8	0,5704	700	43,5	258,5	51,3	52,4	0,6191	M4	710	48,5	263,5	51,7	52,9	0,6289		750	68,5	283,5	53,7	54,9	0,6679		800	93,5	308,5	56	57,3	0,7166		180	-	-	21,3	21,6	0,1236	BFL		M2	200	-	8,5	22,8				23,2	0,1451	225	-			21		24,7	25,1	0,1720			250	-	33,5	26,6	27	0,1989			280	-	48,5	28,7	29,2	0,2311			300	-	59	30,2	30,7	0,2526			BFN																																																																																																																																																																			
150	-	-	17,9	18,1	0,0829		BFL	M2	180	-	-	20				20,3	0,1121	200	-				8,5	21,4	21,7	0,1316			225	-	21	23,2	23,5			0,1560	250	-	33,5	24,9	25,2			0,1804	280	-	48,5	26,9	27,3			0,2096	300	-	59	28,2	28,7	0,2291	315	-	66	29,2	29,7	0,2438	BFN	355	-	86	31,8	32,3	0,2828		400	-	108,5	34,6	35,2	0,3266		450	-	133,5	37,6	38,3	0,3754	BF	M3	500	-	158,5	40,5	41,3			0,4241	550	-	183,5	43,4			44,2	0,4729	560	-	188,5			43,9	44,8	0,4826	600	-			208,5	46,1	47,1	0,5216	630	8,5			223,5	47,7	48,7	0,5509	650	18,5			233,5	48,7	49,8	0,5704	700	43,5	258,5	51,3	52,4	0,6191	M4	710	48,5	263,5	51,7	52,9	0,6289		750	68,5	283,5	53,7	54,9	0,6679		800	93,5	308,5	56	57,3	0,7166		180	-	-	21,3	21,6	0,1236		BFL	M2	200	-	8,5	22,8				23,2	0,1451	225	-				21	24,7	25,1	0,1720			250	-	33,5	26,6	27			0,1989	280	-	48,5	28,7	29,2			0,2311	300	-	59	30,2	30,7			0,2526	BFN																																																																																																																																																																										
180	-	-	20	20,3	0,1121				200	-	8,5	21,4				21,7	0,1316	225	-			21	23,2	23,5	0,1560	250			-	33,5	24,9	25,2	0,1804			280	-	48,5	26,9	27,3	0,2096			300	-	59	28,2	28,7	0,2291	315	-	66	29,2	29,7	0,2438	BFN	355	-	86	31,8	32,3	0,2828	400	-		108,5	34,6	35,2	0,3266	450	-		133,5	37,6	38,3	0,3754	BF	M3	500	-	158,5	40,5	41,3	0,4241	550			-	183,5	43,4	44,2	0,4729			560	-	188,5	43,9	44,8			0,4826	600	-	208,5	46,1			47,1	0,5216	630	8,5	223,5			47,7	48,7	0,5509	650	18,5	233,5			48,7	49,8	0,5704	700	43,5	258,5	51,3	52,4	0,6191	M4	710	48,5	263,5	51,7	52,9	0,6289	750	68,5		283,5	53,7	54,9	0,6679	800	93,5		308,5	56	57,3	0,7166	180	-		-	21,3	21,6	0,1236	BFL	M2		200	-	8,5	22,8	23,2	0,1451				225	-	21	24,7				25,1	0,1720	250	-			33,5	26,6	27	0,1989	280			-	48,5	28,7	29,2	0,2311			300	-	59	30,2	30,7	0,2526			BFN																																																																																																																																																																																			
200	-	8,5	21,4	21,7	0,1316				225	-	21	23,2		23,5		0,1560	250	-	33,5			24,9	25,2	0,1804	280	-			48,5	26,9	27,3	0,2096	300			-	59	28,2	28,7	0,2291	315	-	66	29,2	29,7	0,2438	BFN	355	-	86	31,8	32,3	0,2828	400	-		108,5	34,6	35,2	0,3266	450	-	133,5	37,6		38,3	0,3754	BF	M3	500	-	158,5	40,5	41,3	0,4241	550			-	183,5	43,4	44,2	0,4729	560	-			188,5	43,9	44,8	0,4826	600			-	208,5	46,1	47,1	0,5216			630	8,5	223,5	47,7	48,7			0,5509	650	18,5	233,5	48,7			49,8	0,5704	700	43,5	258,5	51,3	52,4	0,6191	M4	710	48,5	263,5	51,7	52,9	0,6289	750	68,5		283,5	53,7	54,9	0,6679	800	93,5	308,5	56		57,3	0,7166	180	-	-	21,3		21,6	0,1236	BFL	M2	200	-		8,5	22,8	23,2	0,1451				225	-	21	24,7	25,1	0,1720				250	-	33,5	26,6		27		0,1989	280	-	48,5			28,7	29,2	0,2311	300	-			59	30,2	30,7	0,2526	BFN																																																																																																																																																																																														
225	-	21	23,2	23,5	0,1560	250			-	33,5	24,9	25,2		0,1804		280	-	48,5	26,9			27,3	0,2096	300	-	59			28,2	28,7	0,2291	315	-	66	29,2	29,7	0,2438	BFN	355	-	86	31,8	32,3	0,2828	400	-		108,5	34,6	35,2	0,3266	450	-	133,5	37,6		38,3	0,3754	BF	M3	500	-	158,5	40,5	41,3	0,4241	550			-	183,5	43,4	44,2	0,4729	560	-			188,5	43,9	44,8	0,4826	600	-	208,5			46,1	47,1	0,5216	630	8,5			223,5	47,7	48,7	0,5509	650			18,5	233,5	48,7	49,8	0,5704			700	43,5	258,5	51,3	52,4	0,6191	M4	710	48,5	263,5	51,7	52,9	0,6289	750	68,5		283,5	53,7	54,9	0,6679	800	93,5	308,5	56		57,3	0,7166	180	-	-	21,3	21,6	0,1236		BFL	M2	200	-	8,5	22,8		23,2	0,1451			225	-		21	24,7	25,1	0,1720				250	-	33,5	26,6	27	0,1989	280			-	48,5	28,7	29,2		0,2311		300	-	59	30,2			30,7	0,2526	BFN																																																																																																																																																																																																							
250	-	33,5	24,9	25,2	0,1804	280			-	48,5	26,9	27,3		0,2096		300	-	59	28,2			28,7	0,2291	315	-	66	29,2	29,7	0,2438	BFN	355	-	86	31,8	32,3	0,2828	400		-	108,5	34,6	35,2	0,3266	450	-	133,5		37,6	38,3	0,3754	BF	M3	500	-	158,5	40,5	41,3	0,4241			550	-	183,5	43,4	44,2	0,4729	560			-	188,5	43,9	44,8	0,4826	600	-			208,5	46,1	47,1	0,5216	630	8,5	223,5			47,7	48,7	0,5509	650	18,5			233,5	48,7	49,8	0,5704	700			43,5	258,5	51,3	52,4	0,6191	M4	710	48,5	263,5	51,7	52,9	0,6289	750		68,5	283,5	53,7	54,9	0,6679	800	93,5	308,5		56	57,3	0,7166	180	-	-	21,3	21,6		0,1236	BFL	M2	200	-	8,5	22,8	23,2				0,1451	225	-	21		24,7	25,1			0,1720	250		-	33,5	26,6	27			0,1989	280	-	48,5	28,7	29,2	0,2311	300			-	59	30,2	30,7		0,2526		BFN																																																																																																																																																																																																															
280	-	48,5	26,9	27,3	0,2096	300			-	59	28,2	28,7		0,2291		315	-	66	29,2	29,7	0,2438	BFN	355	-	86	31,8	32,3	0,2828	400		-	108,5	34,6	35,2	0,3266	450	-		133,5	37,6	38,3	0,3754	BF	M3	500	-	158,5	40,5	41,3	0,4241			550	-	183,5	43,4	44,2	0,4729			560	-	188,5	43,9	44,8	0,4826	600			-	208,5	46,1	47,1	0,5216	630	8,5			223,5	47,7	48,7	0,5509	650	18,5	233,5			48,7	49,8	0,5704	700	43,5			258,5	51,3	52,4	0,6191	M4	710	48,5	263,5	51,7	52,9	0,6289	750		68,5	283,5	53,7	54,9	0,6679	800	93,5		308,5	56	57,3	0,7166	180	-	-	21,3		21,6	0,1236	BFL	M2	200	-	8,5	22,8		23,2			0,1451	225	-	21	24,7				25,1	0,1720	250	-		33,5	26,6			27	0,1989	280	-	48,5	28,7	29,2			0,2311	300	-	59	30,2	30,7	0,2526	BFN																																																																																																																																																																																																																									
300	-	59	28,2	28,7	0,2291	315			-	66	29,2	29,7	0,2438	BFN	355	-	86	31,8	32,3	0,2828	400		-	108,5	34,6	35,2	0,3266	450	-		133,5	37,6	38,3	0,3754	BF	M3	500	-	158,5	40,5	41,3	0,4241			550	-	183,5	43,4	44,2	0,4729			560	-	188,5	43,9	44,8	0,4826			600	-	208,5	46,1	47,1	0,5216	630			8,5	223,5	47,7	48,7	0,5509	650	18,5			233,5	48,7	49,8	0,5704	700	43,5	258,5			51,3	52,4	0,6191	M4	710	48,5	263,5	51,7	52,9	0,6289	750		68,5	283,5	53,7	54,9	0,6679	800	93,5		308,5	56	57,3	0,7166	180	-	-		21,3	21,6	0,1236	BFL	M2	200	-	8,5		22,8	23,2			0,1451	225	-	21		24,7			25,1	0,1720	250	-	33,5				26,6	27	0,1989	280	-	48,5	28,7			29,2	0,2311	300	-	59	30,2	30,7			0,2526	BFN																																																																																																																																																																																																																															
315	-	66	29,2	29,7	0,2438	BFN	355	-	86	31,8	32,3	0,2828	400		-	108,5	34,6	35,2	0,3266	450	-		133,5	37,6	38,3	0,3754	BF	M3	500	-	158,5	40,5	41,3	0,4241			550	-	183,5	43,4	44,2	0,4729			560	-	188,5	43,9	44,8	0,4826			600	-	208,5	46,1	47,1	0,5216			630	8,5	223,5	47,7	48,7	0,5509	650			18,5	233,5	48,7	49,8	0,5704	700	43,5			258,5	51,3	52,4	0,6191	M4	710	48,5	263,5	51,7	52,9	0,6289	750		68,5	283,5	53,7	54,9	0,6679	800	93,5		308,5	56	57,3	0,7166	180	-	-		21,3	21,6	0,1236	BFL	M2	200	-		8,5	22,8	23,2			0,1451	225	-		21	24,7			25,1	0,1720	250	-		33,5			26,6	27	0,1989	280	-	48,5			28,7	29,2	0,2311	300	-	59	30,2			30,7	0,2526	BFN																																																																																																																																																																																																																																							
355	-	86	31,8	32,3	0,2828		400	-	108,5	34,6	35,2	0,3266	450		-	133,5	37,6	38,3	0,3754	BF	M3	500	-	158,5	40,5	41,3			0,4241	550	-	183,5	43,4	44,2			0,4729	560	-	188,5	43,9	44,8			0,4826	600	-	208,5	46,1	47,1			0,5216	630	8,5	223,5	47,7	48,7			0,5509	650	18,5	233,5	48,7	49,8	0,5704			700	43,5	258,5	51,3	52,4	0,6191	M4	710	48,5	263,5	51,7	52,9	0,6289		750	68,5	283,5	53,7	54,9	0,6679	800		93,5	308,5	56	57,3	0,7166	180	-		-	21,3	21,6	0,1236	BFL	M2	200		-	8,5	22,8			23,2	0,1451		225	-	21			24,7	25,1	0,1720		250	-			33,5	26,6	27	0,1989	280	-			48,5	28,7	29,2	0,2311	300	-			59	30,2	30,7	0,2526	BFN																																																																																																																																																																																																																																														
400	-	108,5	34,6	35,2	0,3266		450	-	133,5	37,6	38,3	0,3754	BF	M3	500	-	158,5	40,5	41,3			0,4241	550	-	183,5	43,4			44,2	0,4729	560	-	188,5	43,9			44,8	0,4826	600	-	208,5	46,1			47,1	0,5216	630	8,5	223,5	47,7			48,7	0,5509	650	18,5	233,5	48,7			49,8	0,5704	700	43,5	258,5	51,3	52,4	0,6191	M4	710	48,5	263,5	51,7	52,9	0,6289		750	68,5	283,5	53,7	54,9	0,6679		800	93,5	308,5	56	57,3	0,7166	180		-	-	21,3	21,6	0,1236	BFL	M2		200	-	8,5	22,8			23,2		0,1451	225	-			21	24,7		25,1	0,1720	250			-	33,5	26,6	27	0,1989	280			-	48,5	28,7	29,2	0,2311	300			-	59	30,2	30,7	0,2526	BFN																																																																																																																																																																																																																																																					
450	-	133,5	37,6	38,3	0,3754	BF	M3	500	-	158,5	40,5	41,3			0,4241	550	-	183,5	43,4			44,2	0,4729	560	-	188,5			43,9	44,8	0,4826	600	-	208,5			46,1	47,1	0,5216	630	8,5	223,5			47,7	48,7	0,5509	650	18,5	233,5			48,7	49,8	0,5704	700	43,5	258,5	51,3	52,4	0,6191	M4	710	48,5	263,5	51,7	52,9	0,6289		750	68,5	283,5	53,7	54,9	0,6679		800	93,5	308,5	56	57,3	0,7166		180	-	-	21,3	21,6	0,1236	BFL		M2	200	-	8,5	22,8				23,2	0,1451	225	-			21		24,7	25,1	0,1720			250	-	33,5	26,6	27	0,1989			280	-	48,5	28,7	29,2	0,2311			300	-	59	30,2	30,7	0,2526			BFN																																																																																																																																																																																																																																																										
500	-	158,5	40,5	41,3	0,4241			550	-	183,5	43,4	44,2			0,4729	560	-	188,5	43,9			44,8	0,4826	600	-	208,5			46,1	47,1	0,5216	630	8,5	223,5			47,7	48,7	0,5509	650	18,5	233,5			48,7	49,8	0,5704	700	43,5	258,5	51,3	52,4	0,6191	M4	710	48,5	263,5	51,7	52,9	0,6289	750		68,5	283,5	53,7	54,9	0,6679	800		93,5	308,5	56	57,3	0,7166	180		-	-	21,3	21,6	0,1236	BFL		M2	200	-	8,5	22,8	23,2				0,1451	225	-	21				24,7	25,1	0,1720	250			-	33,5	26,6	27	0,1989			280	-	48,5	28,7	29,2	0,2311			300	-	59	30,2	30,7	0,2526			BFN																																																																																																																																																																																																																																																																		
550	-	183,5	43,4	44,2	0,4729			560	-	188,5	43,9	44,8			0,4826	600	-	208,5	46,1			47,1	0,5216	630	8,5	223,5			47,7	48,7	0,5509	650	18,5	233,5			48,7	49,8	0,5704	700	43,5	258,5	51,3	52,4	0,6191	M4	710	48,5	263,5	51,7	52,9	0,6289	750		68,5	283,5	53,7	54,9	0,6679	800	93,5		308,5	56	57,3	0,7166	180	-		-	21,3	21,6	0,1236	BFL	M2		200	-	8,5	22,8	23,2				0,1451	225	-	21	24,7				25,1	0,1720	250	-			33,5	26,6	27	0,1989	280			-	48,5	28,7	29,2	0,2311			300	-	59	30,2	30,7	0,2526			BFN																																																																																																																																																																																																																																																																										
560	-	188,5	43,9	44,8	0,4826			600	-	208,5	46,1	47,1			0,5216	630	8,5	223,5	47,7			48,7	0,5509	650	18,5	233,5			48,7	49,8	0,5704	700	43,5	258,5	51,3	52,4	0,6191	M4	710	48,5	263,5	51,7	52,9	0,6289	750		68,5	283,5	53,7	54,9	0,6679	800	93,5		308,5	56	57,3	0,7166	180	-	-		21,3	21,6	0,1236	BFL	M2	200		-	8,5	22,8	23,2				0,1451	225	-	21	24,7				25,1	0,1720	250	-	33,5		26,6		27	0,1989	280	-			48,5	28,7	29,2	0,2311	300			-	59	30,2	30,7	0,2526			BFN																																																																																																																																																																																																																																																																																		
600	-	208,5	46,1	47,1	0,5216			630	8,5	223,5	47,7	48,7			0,5509	650	18,5	233,5	48,7			49,8	0,5704	700	43,5	258,5	51,3	52,4	0,6191	M4	710	48,5	263,5	51,7	52,9	0,6289	750		68,5	283,5	53,7	54,9	0,6679	800	93,5		308,5	56	57,3	0,7166	180	-	-		21,3	21,6	0,1236	BFL	M2	200	-		8,5	22,8	23,2			0,1451		225	-	21	24,7				25,1	0,1720	250	-	33,5		26,6		27	0,1989	280	-	48,5		28,7		29,2	0,2311	300	-			59	30,2	30,7	0,2526	BFN																																																																																																																																																																																																																																																																																												
630	8,5	223,5	47,7	48,7	0,5509			650	18,5	233,5	48,7	49,8			0,5704	700	43,5	258,5	51,3	52,4	0,6191	M4	710	48,5	263,5	51,7	52,9	0,6289	750		68,5	283,5	53,7	54,9	0,6679	800	93,5		308,5	56	57,3	0,7166	180	-	-		21,3	21,6	0,1236	BFL	M2	200	-		8,5	22,8	23,2			0,1451	225		-	21	24,7			25,1		0,1720	250	-	33,5			26,6	27	0,1989	280	-	48,5		28,7		29,2	0,2311	300	-	59		30,2		30,7	0,2526	BFN																																																																																																																																																																																																																																																																																																				
650	18,5	233,5	48,7	49,8	0,5704			700	43,5	258,5	51,3	52,4	0,6191	M4	710	48,5	263,5	51,7	52,9	0,6289	750		68,5	283,5	53,7	54,9	0,6679	800	93,5		308,5	56	57,3	0,7166	180	-	-		21,3	21,6	0,1236	BFL	M2	200	-		8,5	22,8	23,2			0,1451	225		-	21	24,7			25,1	0,1720		250	-	33,5			26,6	27	0,1989	280	-	48,5			28,7	29,2	0,2311	300	-	59		30,2		30,7	0,2526	BFN																																																																																																																																																																																																																																																																																																												
700	43,5	258,5	51,3	52,4	0,6191	M4	710	48,5	263,5	51,7	52,9	0,6289	750		68,5	283,5	53,7	54,9	0,6679	800	93,5		308,5	56	57,3	0,7166	180	-	-		21,3	21,6	0,1236	BFL	M2	200	-		8,5	22,8	23,2			0,1451	225		-	21	24,7			25,1	0,1720		250	-	33,5			26,6	27	0,1989	280	-	48,5			28,7	29,2	0,2311	300	-	59			30,2	30,7	0,2526	BFN																																																																																																																																																																																																																																																																																																																				
710	48,5	263,5	51,7	52,9	0,6289		750	68,5	283,5	53,7	54,9	0,6679	800		93,5	308,5	56	57,3	0,7166	180	-		-	21,3	21,6	0,1236	BFL	M2	200		-	8,5	22,8			23,2	0,1451		225	-	21			24,7	25,1		0,1720	250	-			33,5	26,6	27	0,1989	280	-			48,5	28,7	29,2	0,2311	300	-			59	30,2	30,7	0,2526	BFN																																																																																																																																																																																																																																																																																																																											
750	68,5	283,5	53,7	54,9	0,6679		800	93,5	308,5	56	57,3	0,7166	180		-	-	21,3	21,6	0,1236	BFL	M2		200	-	8,5	22,8			23,2		0,1451	225	-			21	24,7		25,1	0,1720	250			-	33,5	26,6	27	0,1989	280			-	48,5	28,7	29,2	0,2311	300			-	59	30,2	30,7	0,2526	BFN																																																																																																																																																																																																																																																																																																																																		
800	93,5	308,5	56	57,3	0,7166		180	-	-	21,3	21,6	0,1236	BFL		M2	200	-	8,5	22,8				23,2	0,1451	225	-			21		24,7	25,1	0,1720			250	-	33,5	26,6	27	0,1989			280	-	48,5	28,7	29,2	0,2311			300	-	59	30,2	30,7	0,2526			BFN																																																																																																																																																																																																																																																																																																																																							
180	-	-	21,3	21,6	0,1236		BFL	M2	200	-	8,5	22,8				23,2	0,1451	225	-				21	24,7	25,1	0,1720			250	-	33,5	26,6	27			0,1989	280	-	48,5	28,7	29,2			0,2311	300	-	59	30,2	30,7			0,2526	BFN																																																																																																																																																																																																																																																																																																																																														
200	-	8,5	22,8	23,2	0,1451				225	-	21	24,7				25,1	0,1720	250	-			33,5	26,6	27	0,1989	280			-	48,5	28,7	29,2	0,2311			300	-	59	30,2	30,7	0,2526			BFN																																																																																																																																																																																																																																																																																																																																																							
225	-	21	24,7	25,1	0,1720				250	-	33,5	26,6		27		0,1989	280	-	48,5			28,7	29,2	0,2311	300	-			59	30,2	30,7	0,2526	BFN																																																																																																																																																																																																																																																																																																																																																																		
250	-	33,5	26,6	27	0,1989	280			-	48,5	28,7	29,2		0,2311		300	-	59	30,2			30,7	0,2526	BFN																																																																																																																																																																																																																																																																																																																																																																											
280	-	48,5	28,7	29,2	0,2311	300			-	59	30,2	30,7		0,2526		BFN																																																																																																																																																																																																																																																																																																																																																																																			
300	-	59	30,2	30,7	0,2526	BFN																																																																																																																																																																																																																																																																																																																																																																																													
BFN																																																																																																																																																																																																																																																																																																																																																																																																			

Sizes in increments of 5 mm can be manufactured on request.

* For designs with BKN a weight of 0.5 kg must be added.

A x B [mm]	Damper blade overlaps		Weight		Free area S _f [m ²]	Spring return actuator	Manual control	A x B [mm]	Damper blade overlaps		Weight		Free area S _f [m ²]	Spring return actuator	Manual control
	a [mm]	c [mm]	Man. [kg]	Actu. [kg]*					a [mm]	c [mm]	Man. [kg]	Actu. [kg]*			
1500 x	180	-	-	26,2	26,6	0,1696		1500 x	500	-	158,5	53,7	54,9	0,6416	
	200	-	8,5	28,2	28,7	0,1991	BFL		550	-	183,5	57,1	58,5	0,7154	M3
	225	-	21	30,7	31,2	0,2360			560	-	188,5	57,8	59,2	0,7301	
	250	-	33,5	33	33,6	0,2729	M2		600	-	208,5	60,3	61,9	0,7891	M4
	280	-	48,5	35,8	36,5	0,3171			630	8,5	223,5	62,2	63,8	0,8334	
	300	-	59	37,6	38,3	0,3466	BFN		650	18,5	233,5	63,3	65	0,8629	BF
	315	-	66	38,9	39,7	0,3688			700	43,5	258,5	66,1	68	0,9366	
	355	-	86	42,4	43,2	0,4278			710	48,5	263,5	66,6	68,5	0,9514	M5
	400	-	108,5	46,1	47,1	0,4941			750	68,5	283,5	68,6	70,7	1,0104	
	450	-	133,5	50	51,1	0,5679	BF		M3	800	93,5	308,5	70,9	73,1	1,0841

Sizes in increments of 5 mm can be manufactured on request.

* For designs with BKN a weight of 0.5 kg must be added.

IV. INSTALLATION

Placement and installation

- The fire dampers are suitable for installation in arbitrary position in vertical and horizontal passages of fire separating constructions. The damper installation procedures must be done so that all load transfer from the fire separating constructions to the damper is absolutely excluded. Following air-conditioning duct must be suspended or supported so that all load transfer from the following duct to the fire damper is absolutely excluded. The gap between the installed damper and the fire separating construction must be perfectly filled with approved material.
- The damper must be installed so that the damper blade (in closed position) is situated in the fire separating construction - marked by the label BUILT-IN EDGE on the damper casing. If such solution is not possible, the duct between the fire separating construction and the damper blade must be protected according to the certified installation method → see pages 25 to 73
- During the installation and plastering process, the actuating mechanism must be protected (covered) against damage and pollution. The damper casing should not be deformed during bricking in. Once the damper is built in, the damper blade should not grind against the damper casing during opening or closing.
- The distance between the fire damper and the construction (wall, ceiling) must be 75 mm at the minimum, according to EN 1366-2. If two or more dampers are to be installed in one fire separating construction, the distance between adjacent dampers must be 200 mm at the minimum, according to EN 1366-2.
- Fire dampers can be installed without following duct on one or both sides. Installation without following duct is only possible in vertical constructions. In this case, the fire dampers must be installed with cover grilles (additional extension parts may be required due to overlapping of the damper blade → see pages 16 to 21). The damper must be installed so that the activation device (thermal fuse/thermoelectric activation device/smoke detector) is located at the highest possible point of the damper (top of the casing).

Minimum distance between the fire dampers and the construction

- minimum distance 200 mm between dampers, according to EN 1366-2
- minimum distance 75 mm between damper and construction (wall/ceiling), according to EN 1366-2
- recommended minimum distance 150 mm necessary for access to the actuator
- recommended minimum distance 250 mm necessary for access to the manual control

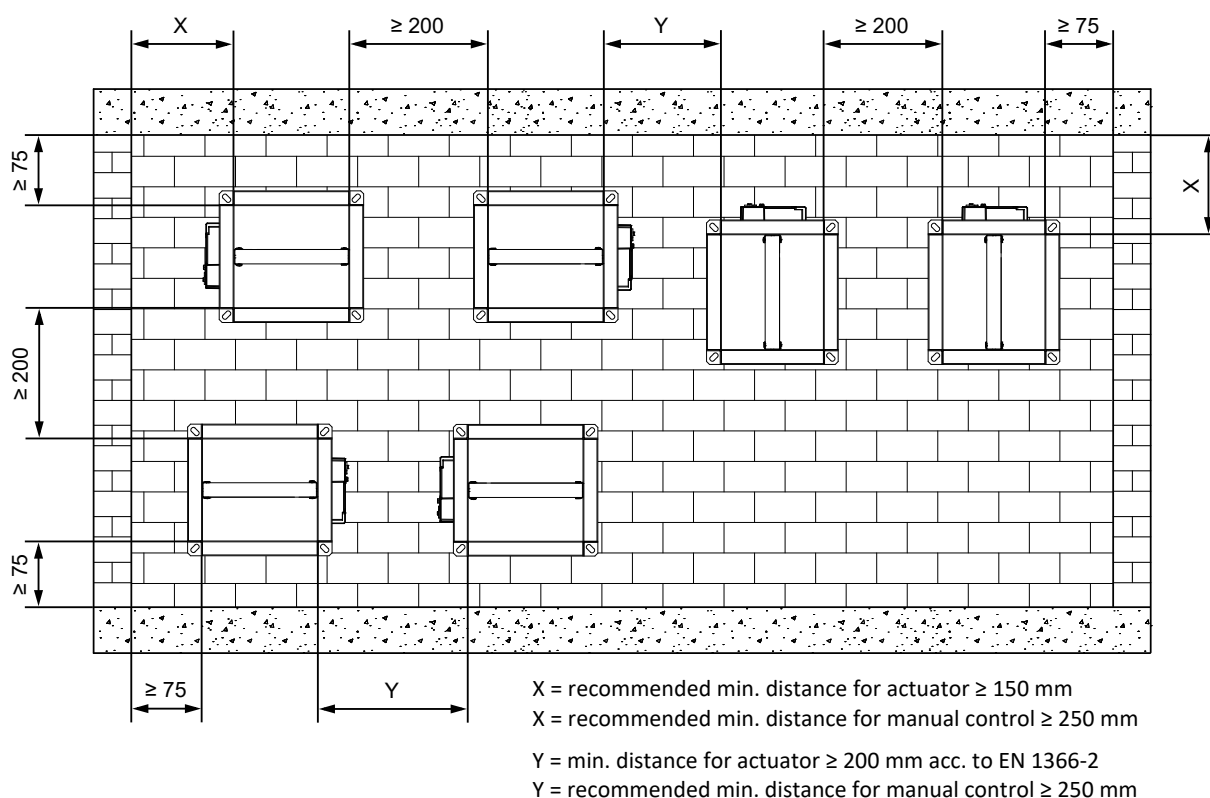

Built in edge

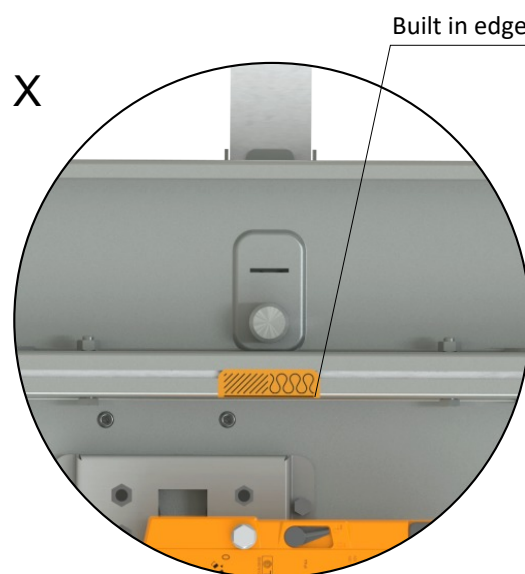
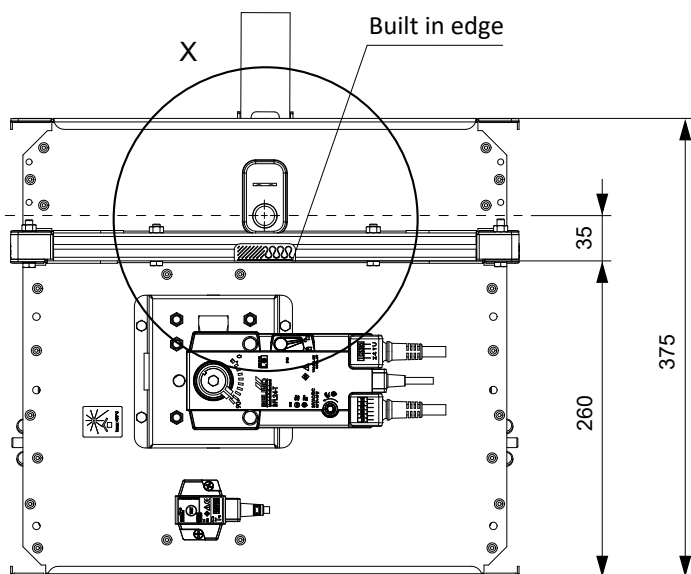

Dimensions of an installation opening

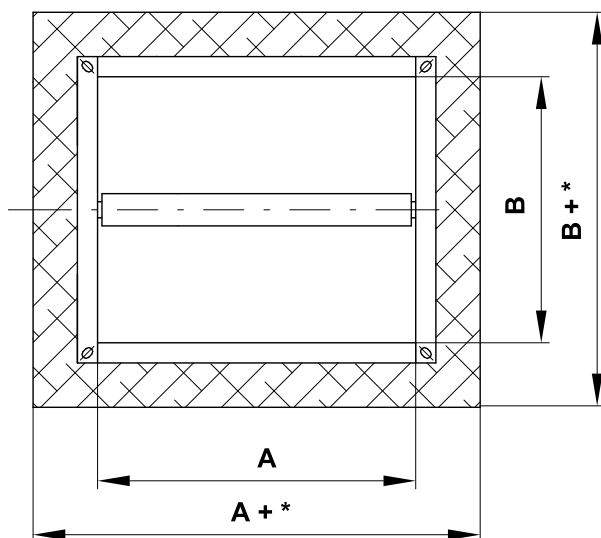

- * Mortar or gypsum
 - min. A(B)+100
 - max. A(B)+300
- * Ablative Coated Batt
 - min. A(B)+80
 - max. A(B)+800
- * Stuffing box with fire protective boards
 - min. A(B)+80
 - max. A(B)+220

Examples of constructions for fire damper installation

- The fire damper can be installed into:
 - Solid wall construction made e.g. of normal concrete/masonry or porous concrete with min. thickness 100 mm.
 - Gypsum wall construction with min. thickness 100 mm.
 - Solid ceiling construction made e.g. of normal concrete or porous concrete, with minimum thickness according to EN 1366-2.
- Outside the wall/ceiling construction. The duct and damper must be protected by fire insulation.
- If the damper is installed outside the fire separation construction, a damper side A ≥ 800 mm and fire resistance is EI 90 S, VRM-Q reinforcement frame must be used. → see page 86

NOTE: For lower fire resistance than EI 90 S, VRM-Q reinforcement frame is not necessary!

Statement of installations

Placement	wall/ceiling min. thickness [mm]	Method of installation	Fire resistance	Page
In solid wall construction	100	Mortar or gypsum	EI 90 (v _e i↔o) S	25
		2 dampers in battery - mortar or gypsum		26
		4 dampers in battery - mortar or gypsum		27
		Ablative Coated Batt		28
		Mineral wool with fire-resistant coating and fire-resistant boards		29
		Installation next to the wall/ceiling - mortar or gypsum + mineral wool		30
Outside solid wall construction	100	ISOVER Ultimate Protect - mortar or gypsum	EI 60 (v _e i↔o) S	31
		ISOVER Ultimate Protect - Ablative Coated Batt		32
		Mineral wool ROCKWOOL - Mineral wool with fire-resistant coating and fireresistant board		EI 90 (v _e i↔o) S
In gypsum wall construction	100	Mortar or gypsum	EI 90 (v _e i↔o) S	34
		2 dampers in battery - mortar or gypsum		35
		4 dampers in battery - mortar or gypsum		36
		Ablative Coated Batt		37
		Mineral wool with fire-resistant coating and fire-resistant boards		38
		Installation next to the wall/ceiling - mortar or gypsum + mineral wool		39
Outside gypsum wall construction	100	ISOVER Ultimate Protect - mortar or gypsum	EI 60 (v _e i↔o) S	40
		ISOVER Ultimate Protect - Ablative Coated Batt		41
		Mineral wool ROCKWOOL - Mineral wool with fire-resistant coating and fireresistant boards		EI 90 (v _e i↔o) S
In sandwich wall construction	100	Ablative Coated Batt with fire-resistant boards	EI 90 (v _e i↔o) S	43
In shaft wall Rigips	110	Mortar or gypsum	EI 90 (v _e i↔o) S	45
	80	Installation frame E1		46
In solid ceiling construction	150	Mortar or gypsum	EI 90 (h _o i↔o) S	47
		2 dampers in battery - mortar or gypsum		48
		4 dampers in battery - mortar or gypsum		49
		Ablative Coated Batt		50
		Mineral wool with fire-resistant coating and fire-resistant boards		51
Outside solid ceiling construction	150	Mineral wool ROCKWOOL - mortar or gypsum	EI 90 (h _o i↔o) S	52
		Concreting		53
Installation frame in solid wall construction	100	Installation frame E1	EI 90 (v _e i↔o) S	56
		Installation frame E2		60
		Installation frame E4		65
Installation frame outside solid wall construction	100	Insulation from fire-resistant boards - mortar or gypsum - installation frame E6	EI 90 (v _e i↔o) S	72
Installation frame in gypsum wall construction	100	Installation frame E1	EI 90 (v _e i↔o) S	57
		Installation frame E3		63
		Flexible ceiling - installation frame E5		69-70
Installation frame in solid ceiling construction	150	Installation frame E1	EI 90 (h _o i↔o) S	58
		Installation frame E2		61
		Installation frame E4		66
Installation frame outside solid ceiling construction	150	Concreting - Installation frame E4	EI 90 (h _o i↔o) S	67
		Insulation from fire-resistant boards - mortar or gypsum - installation frame E6		73

In solid wall construction

In solid wall construction - mortar or gypsum

EI 90 (v_e i↔o) S

- For connection of following duct → see page 78

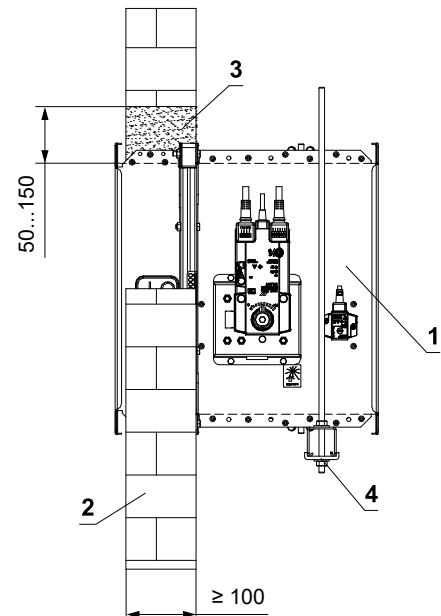
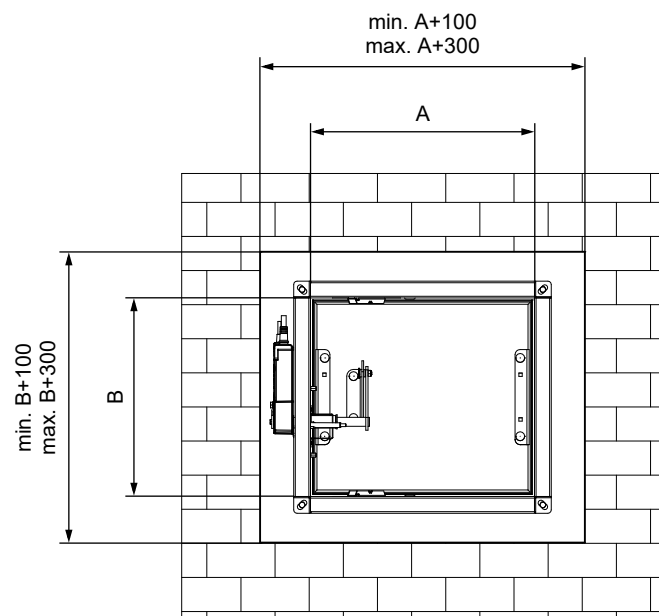
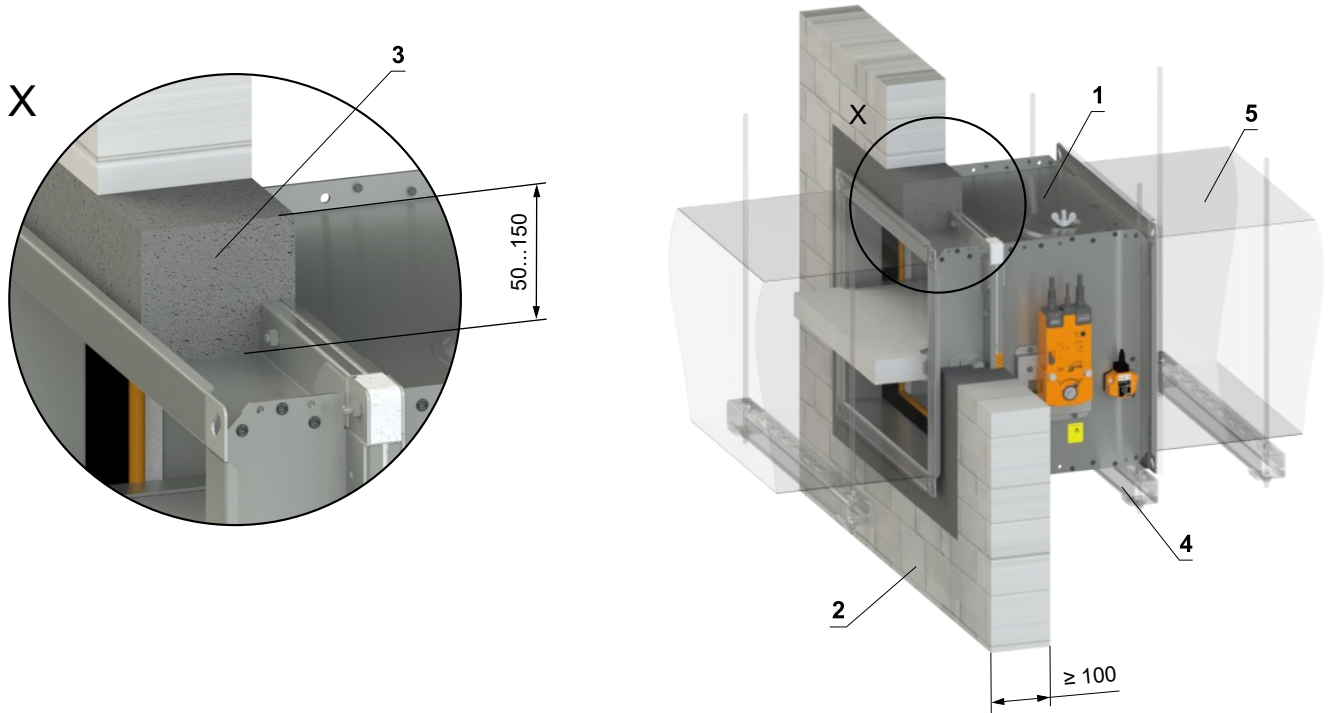

- 1 FDMQ
- 2 Solid wall construction
- 3 Mortar or gypsum
- 4 Profile with threaded rod → see pages 74 to 77
- 5 Duct

In solid wall construction - 2 dampers in battery - mortar or gypsum

EI 90 (v_e i↔o) S

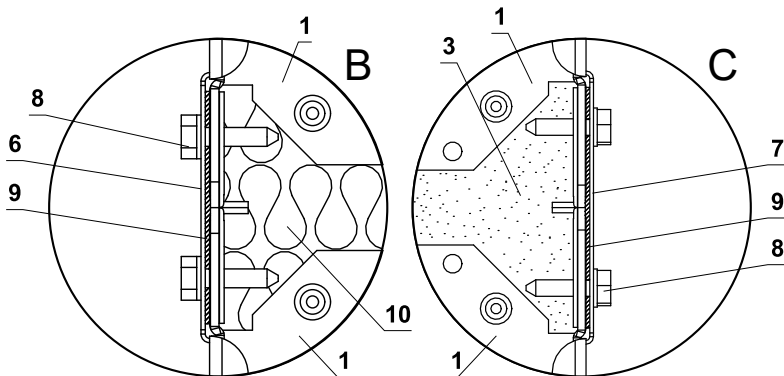
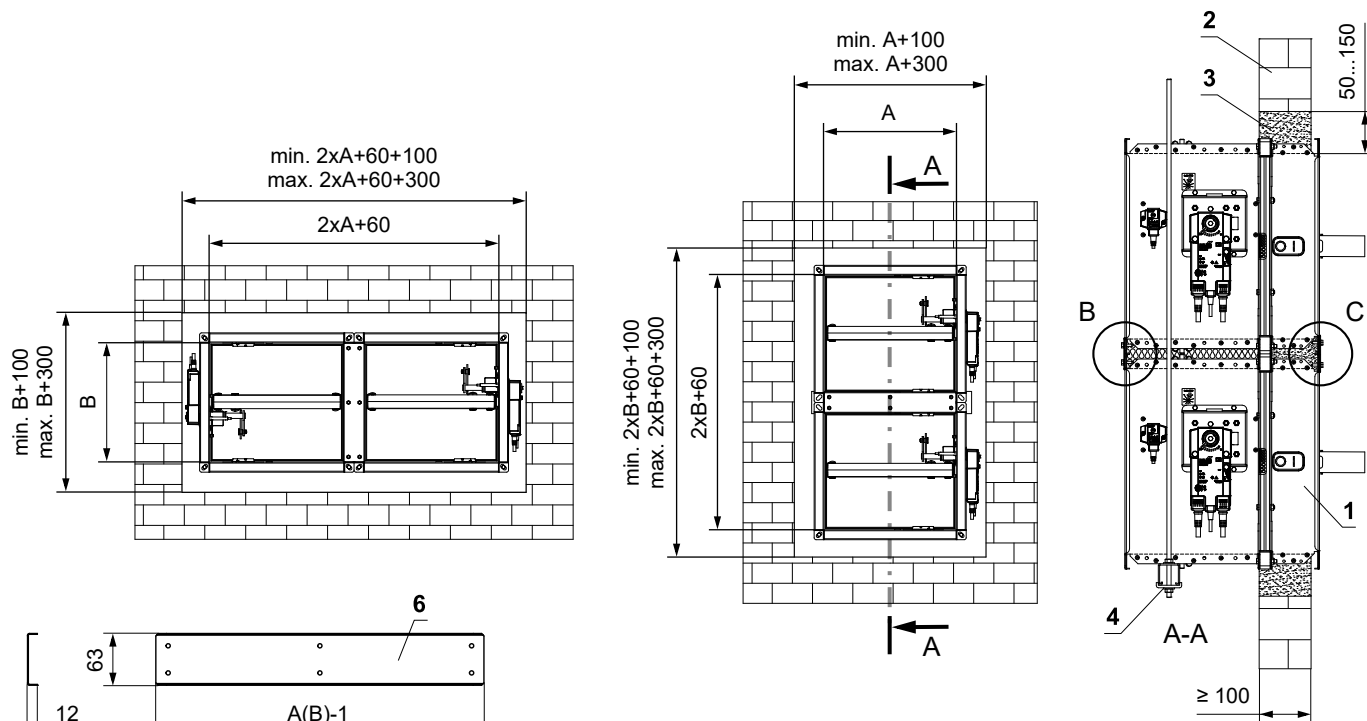
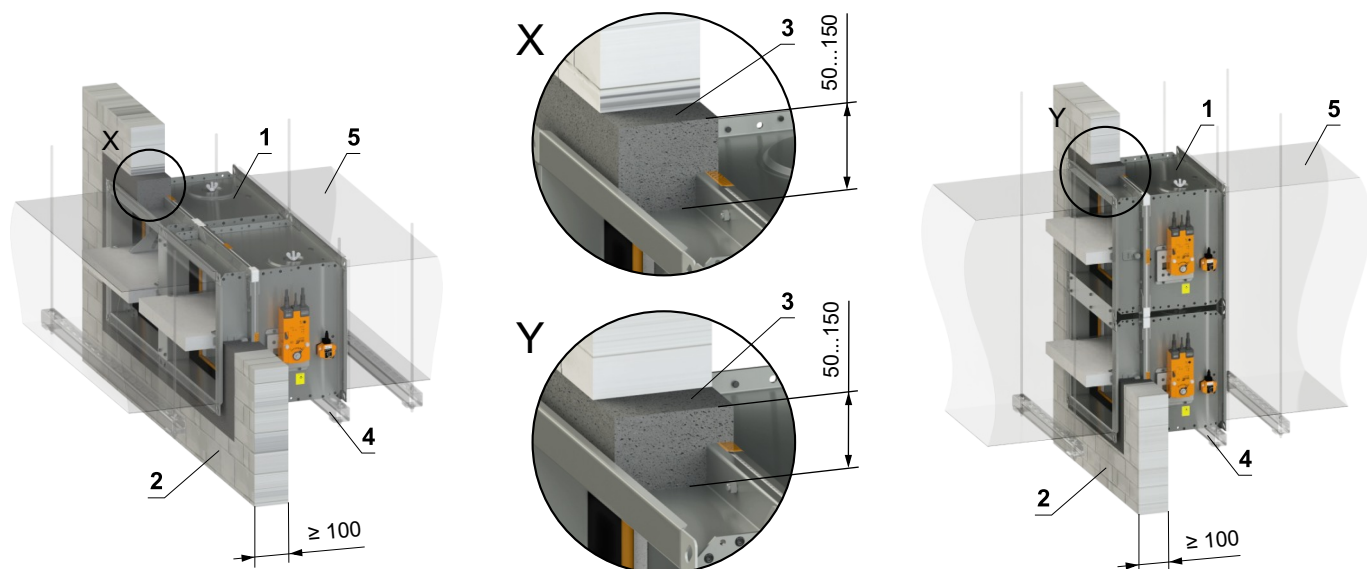

- 1 FDMQ
- 2 Solid wall construction
- 3 Mortar or gypsum
- 4 Profile with threaded rod → see pages 74 to 77
- 5 Duct
- 6 U-profile type 3
- 7 U-profile type 1
- 8 Screw TEX 4,8x18 mm (pitch ≤ 200 mm)
- 9 Sealing
- 10 Insulation board made of mineral wool - recommended for easy filling of gap with mortar/gypsum.

- For connection of following duct → see page 78
- The gap between the damper and construction is filled with mortar or gypsum

In solid wall construction - 4 dampers in battery - mortar or gypsum

EI 90 (v_e i↔o) S

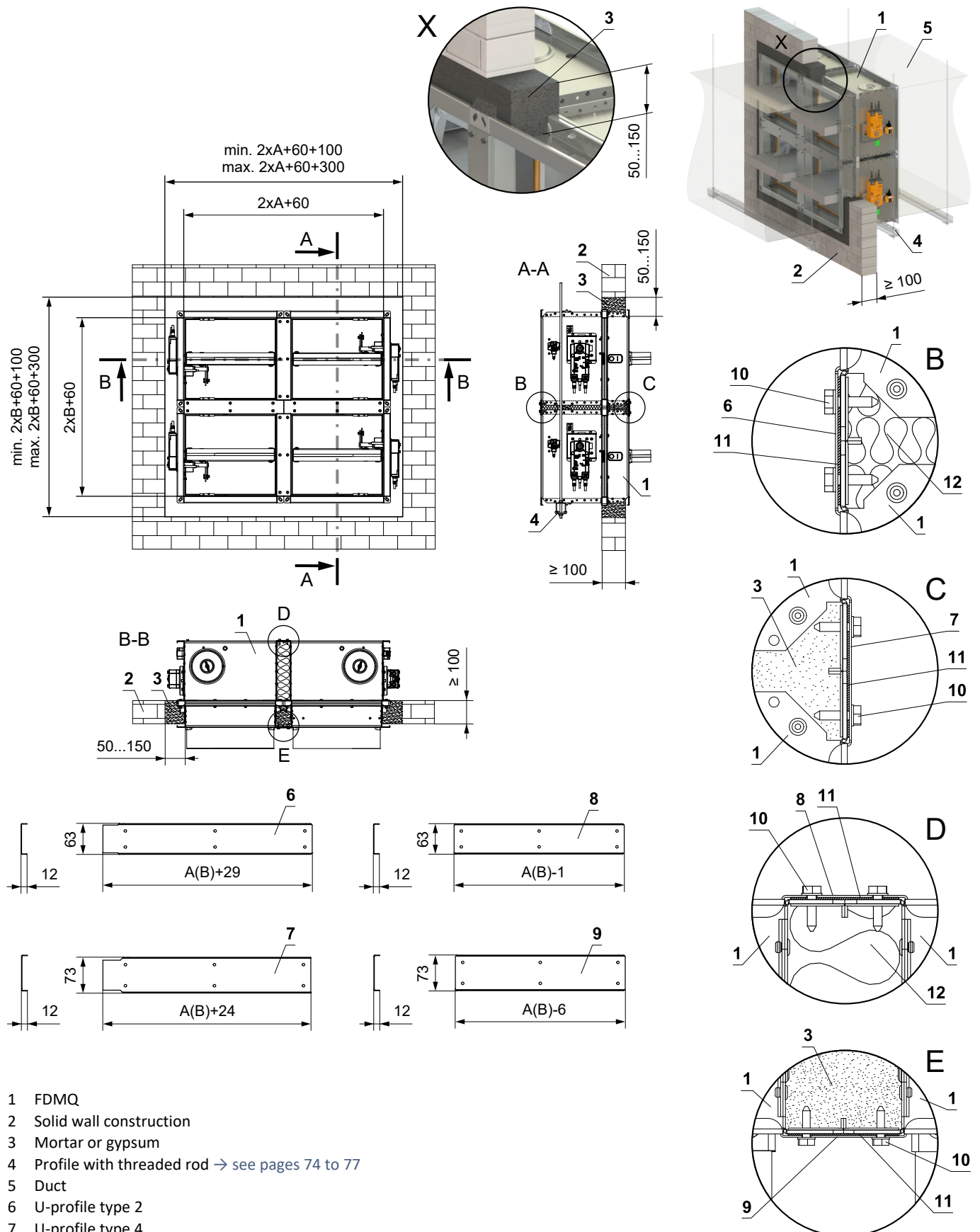

- 1 FDMQ
- 2 Solid wall construction
- 3 Mortar or gypsum
- 4 Profile with threaded rod → see pages 74 to 77
- 5 Duct
- 6 U-profile type 2
- 7 U-profile type 4
- 8 U-profile type 1
- 9 U-profile type 3
- 10 Screw TEX 4,8x18 mm (pitch ≤ 200 mm)
- 11 Sealing
- 12 Insulation board made of mineral wool - recommended for easy filling of gap with mortar/gypsum.

- For connection of following duct → see page 78
- The gap between the damper and construction is filled with mortar or gypsum

In solid wall construction - Ablative Coated Batt

EI 90 (v_e i↔o) S

■ For connection of following duct → see page 78

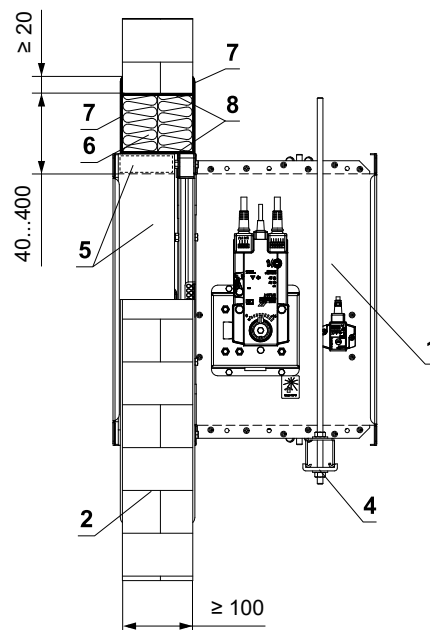
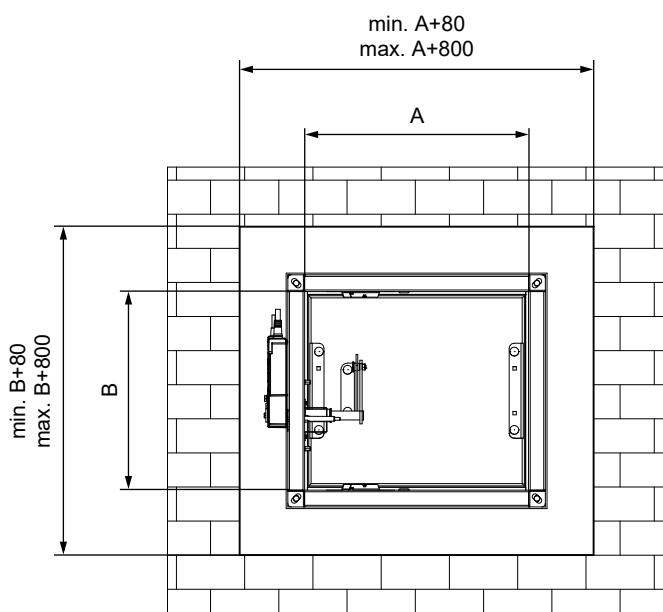
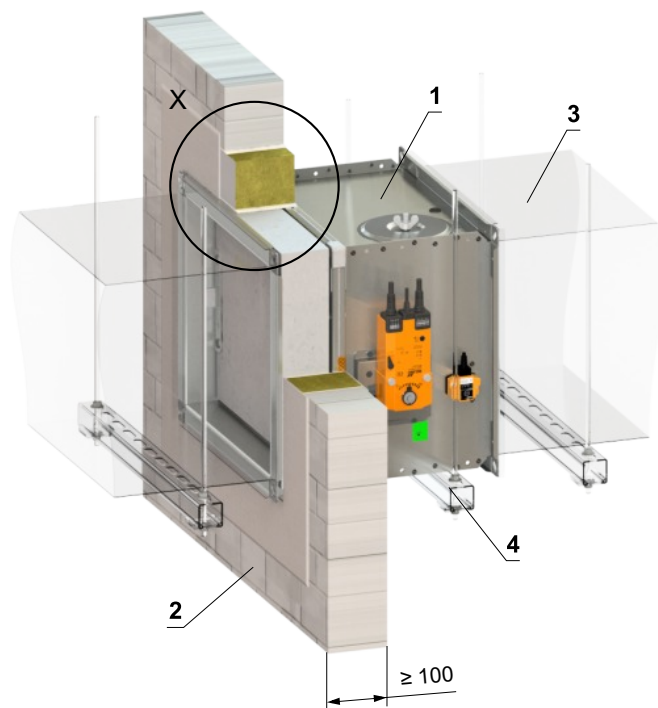
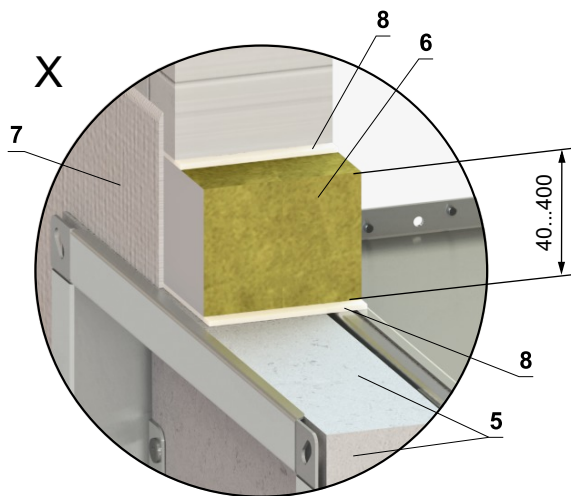

- 1 FDMQ
- 2 Solid wall construction
- 3 Duct
- 4 Profile with threaded rod → see pages 74 to 77
- 5 Protective cladding board - min. th. 30 mm, min. density 750 kg/m³ (e.g. PROMATECT-MST) → see page 87
Ablative Coated Batt System HILTI*
- 6 Mineral wool board - min. density 140 kg/m³ (HILTI CFS-CT B 1S 140/50...)
- 7 Fire stop coating - th. 1 mm (HILTI CFS-CT...) - coating is overcoated on the support construction and on the damper casing/duct
- 8 Fire-resistant mastic - (HILTI CFS-S ACR...) fill the gap from both sides of the fire separation construction and around the perimeter of penetration and damper casing

* HILTI system can be replaced by a similar system with the same or higher thickness, density, fire reaction class, tested according to EN 1366-3.

In solid wall construction - mineral wool with fire-resistant coating and fire-resistance boards

EI 90 (v_e i↔o) S

■ For connection of following duct → see page 78

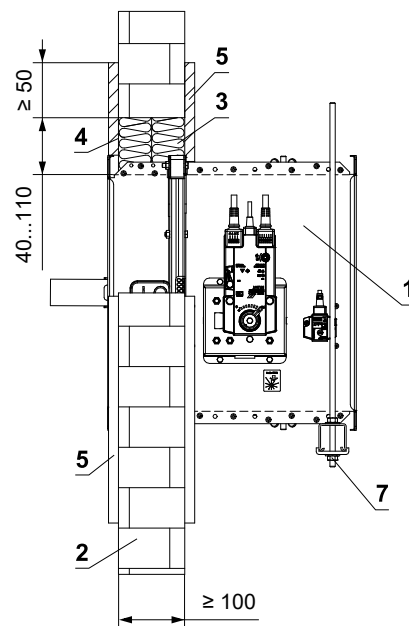
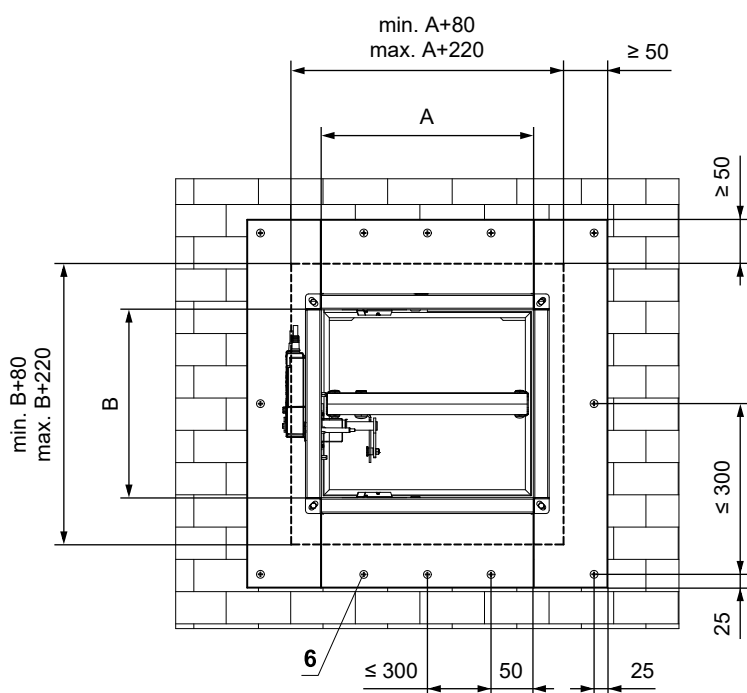
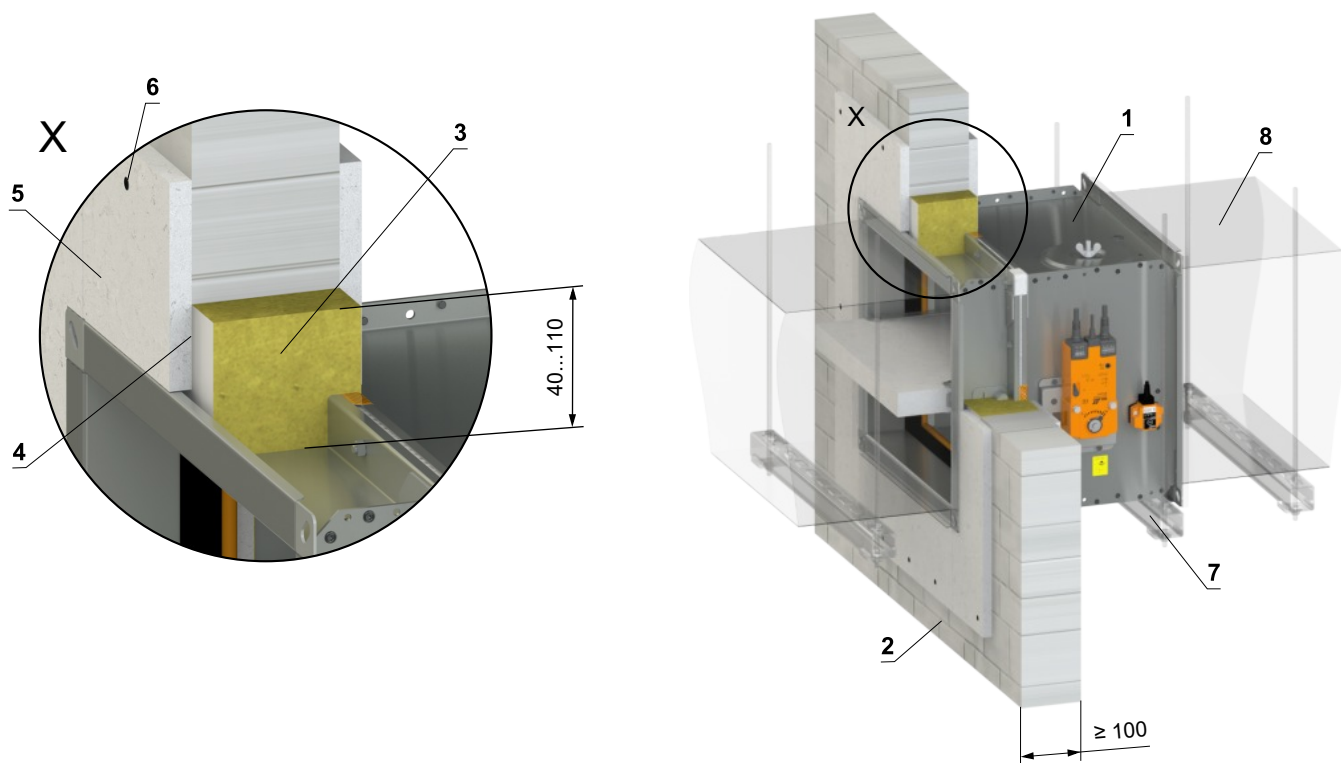

- 1 FDMQ
- 2 Solid wall construction
- 3 Mineral wool board - min. density 140 kg/m³ (e.g. PROMAPYR-T150, ROCKWOOL HARDROCK / STEPROCK HD)
- 4 Fire-resistant coating - th. 1 mm (e.g. PROMASTOP-I)
- 5 Fire-resistant board - min. th. 15 mm, min. density 870 kg/m³ (e.g. PROMATECT-H)
- 6 Screw 4x50 mm - screws must be fixed in the wall construction, use steel anchors if necessary
- 7 Profile with threaded rod → see pages 74 to 77
- 8 Duct

In solid wall construction - installation next to the wall/ceiling - mortar or gypsum + mineral wool

EI 90 (v_e i↔o) S

- For connection of following duct → see page 78
- Conditions of this installation are also valid for the installation in **Solid ceiling construction**
- Penetration is filled with mortar or gypsum + mineral wool (shape, according to the location of the damper). Fix the mineral wool with glue (e.g. Promat K84 or equivalent) to the construction and damper casing

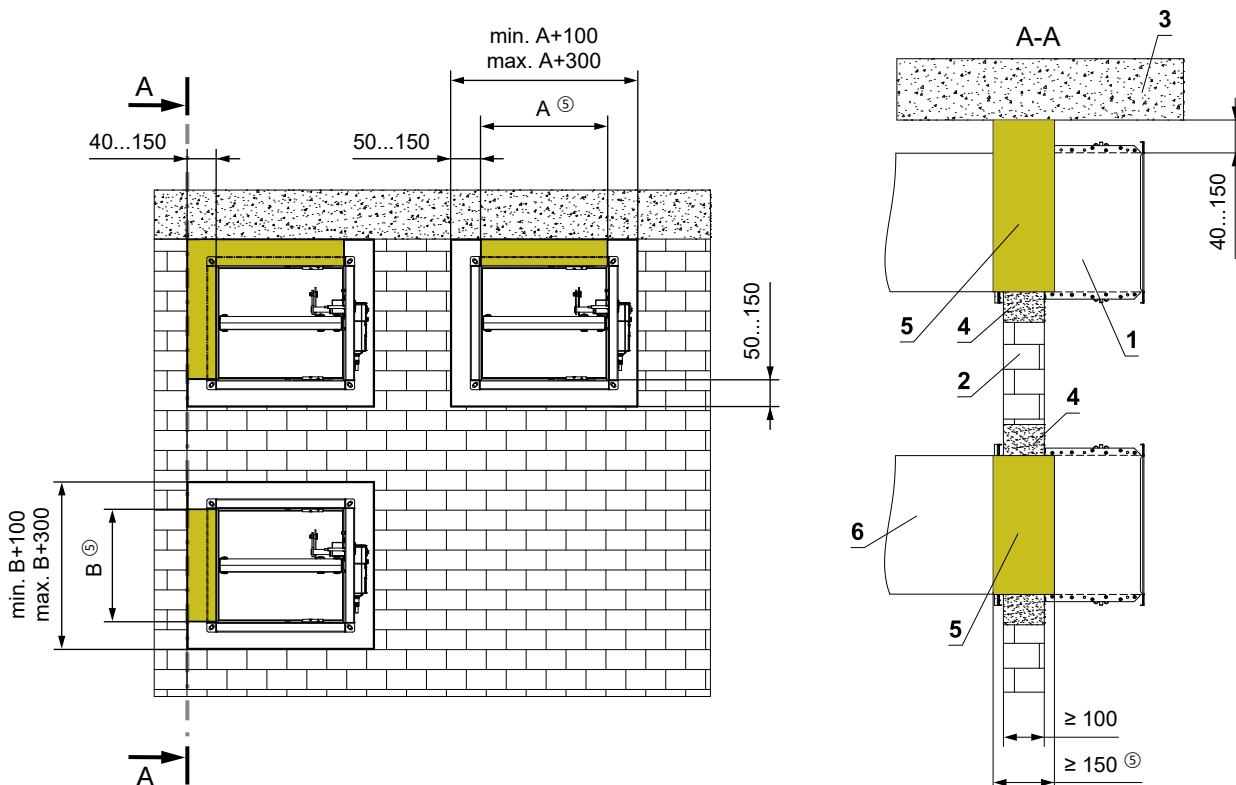
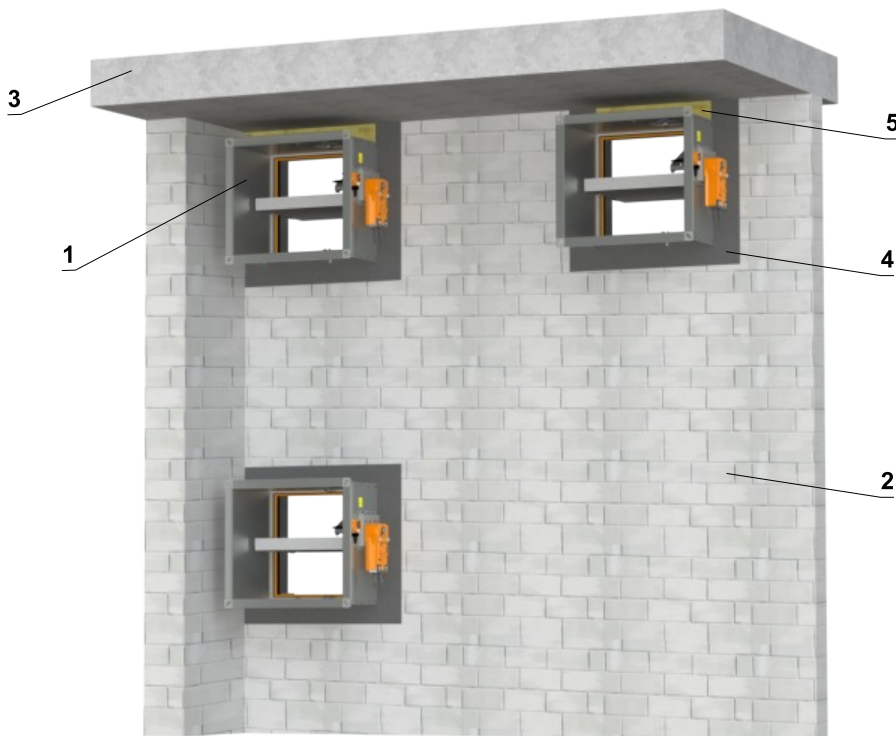

- 1 FDMQ
- 2 Solid wall construction
- 3 Solid ceiling construction
- 4 Mortar or gypsum
- 5 Mineral wool board - min. density 140 kg/m³ (e.g. PROMAPYR-T150, ROCKWOOL HARDROCK / STEPROCK HD)
- 6 Duct

Installation outside solid wall construction

Outside solid wall construction - ISOVER Ultimate Protect - mortar or gypsum

EI 60 (v_e i↔o) S

- For connection of following duct → see page 78
- Minimum and maximum distance between the wall and fire damper is unlimited
- When installing the insulation, follow the ISOVER manufacturer's instructions
- The damper and the duct must be suspended separately
- The duct must be suspended on both sides of damper acc. to national rules
- Duct between fire damper and fire separating construction must be suspended by using threaded rods and mounting profiles, or another mounting system acc. to national standards
- Load of the suspension system depends on weight of the fire damper and duct system → see page 74
- Max. distance between two suspension systems is 1500 mm
- Following air-conditioning duct must be suspended or supported so that all load transfer from the following duct to the fire damper is absolutely excluded. Adjacent duct must be suspended or supported, as required by the duct suppliers
- If the threaded rod is located inside the duct insulation, distance between threaded rod and duct is max 30 mm
- If the threaded rod is located outside the duct isolation, distance between threaded rod and isolation is max. 40 mm

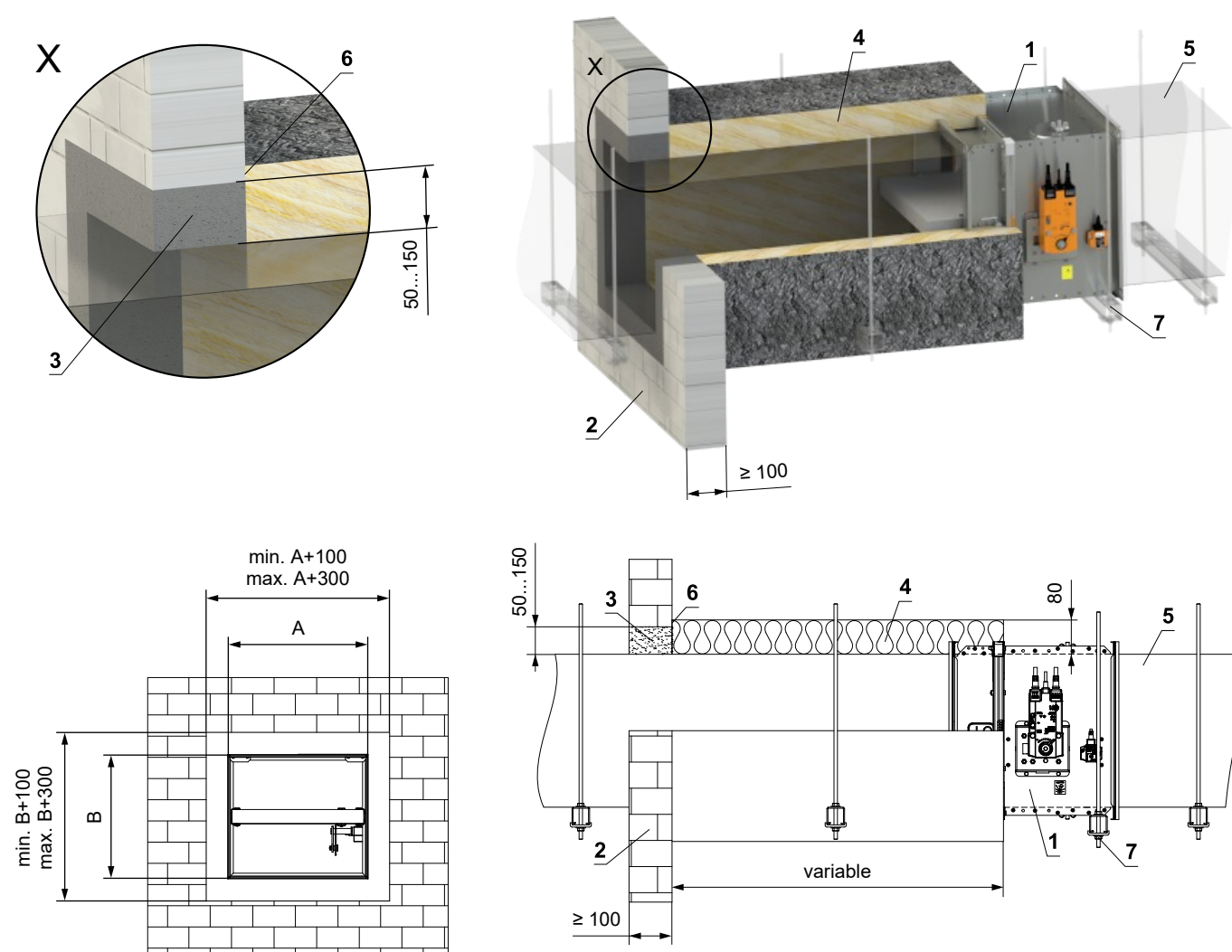

- 1 FDMQ
- 2 Solid wall construction
- 3 Mortar or gypsum
- 4 Insulation board made of mineral wool, with a surface treatment of aluminum foil, min. thickness 80 mm, min. density 66 kg/m³ (System ISOVER Ultimate Protect Wired Mat 4.0 Alu1)
- 5 Standard air duct, made of galvanized sheet metal min. thickness 0,8 mm – the duct must be anchored on both sides of the fire-separating structure, e.g. using L-profiles 30 × 30 × 3 mm – according to the ISOVER manufacturer's instructions
- 6 ISOVER Protect BSK glue - apply on the insulation and fix it to the fire separation construction
- 7 Profile with threaded rod → see pages 74 to 77

Outside solid wall construction - ISOVER Ultimate Protect - Ablative Coated Batt

EI 60 (v_e i↔o) S

- For connection of following duct → see page 78
- Minimum and maximum distance between the wall and fire damper is unlimited
- When installing the insulation, follow the ISOVER manufacturer's instructions
- The damper and the duct must be suspended separately
- The duct must be suspended on both sides of damper acc. to national rules
- Duct between fire damper and fire separating construction must be suspended by using threaded rods and mounting profiles, or another mounting system acc. to national standards
- Load of the suspension system depends on weight of the fire damper and duct system → see page 74
- Max. distance between two suspension systems is 1500 mm
- Following air-conditioning duct must be suspended or supported so that all load transfer from the following duct to the fire damper is absolutely excluded. Adjacent duct must be suspended or supported, as required by the duct suppliers
- If the threaded rod is located inside the duct insulation, distance between threaded rod and duct is max 30 mm
- If the threaded rod is located outside the duct isolation, distance between threaded rod and isolation is max. 40 mm

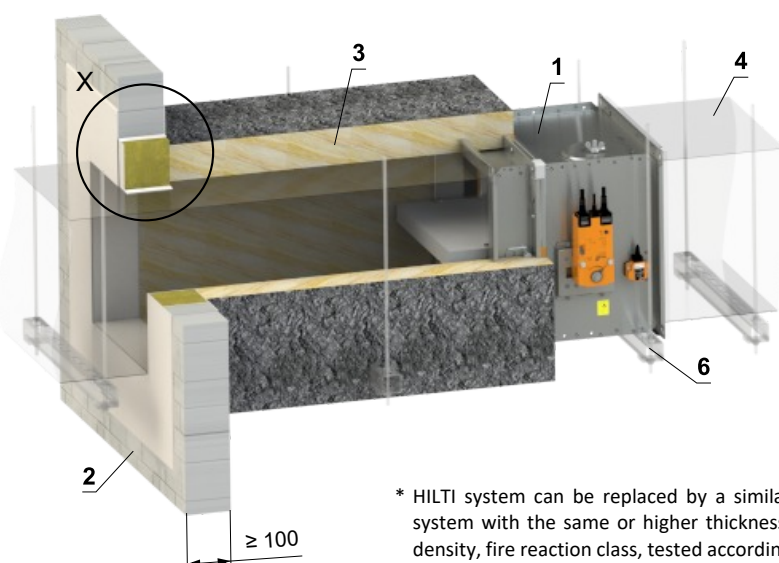
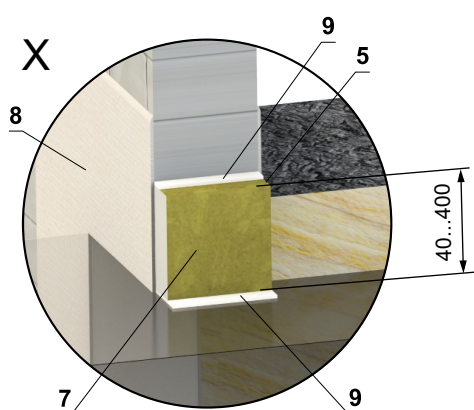

* HILTI system can be replaced by a similar system with the same or higher thickness, density, fire reaction class, tested according to EN 1366-3.

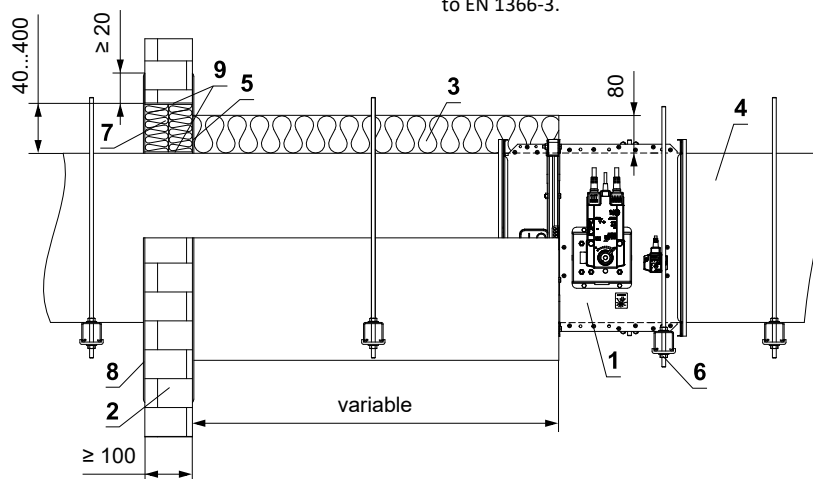
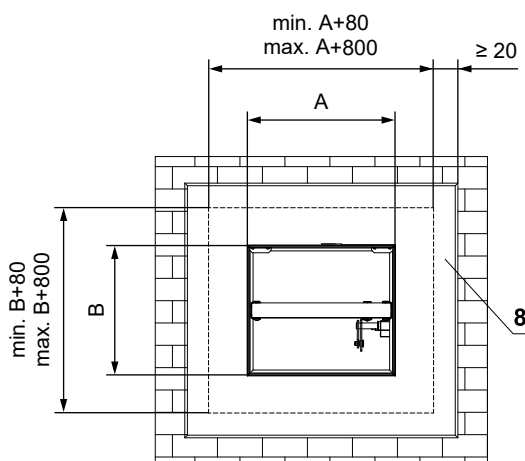

- 1 FDMQ
- 2 Solid wall construction
- 3 Insulation board made of mineral wool, with a surface treatment of aluminum foil, min. thickness 80 mm, min. density 66 kg/m³ (System ISOVER Ultimate Protect Wired Mat 4.0 Alu1)
- 4 Standard air duct, made of galvanized sheet metal min. thickness 0,8 mm – the duct must be anchored on both sides of the fire-separating structure, e.g. using L-profiles 30 × 30 × 3 mm – according to the ISOVER manufacturer's instructions
- 5 ISOVER Protect BSK glue - apply on the insulation and fix it to the fire separation construction
- 6 Profile with threaded rod → see pages 74 to 77
Ablative Coated Batt System HILTI*
- 7 Mineral wool board - min. density 140 kg/m³ (HILTI CFS-CT B 1S 140/50...)
- 8 Fire stop coating - th. 1 mm (HILTI CFS-CT...) - coating is overcoated on the support construction and on the damper casing/duct
- 9 Fire-resistant mastic - (HILTI CFS-S ACR...) fill the gap from both sides of the fire separation construction and around the perimeter of penetration and damper casing

Outside solid wall construction - mineral wool ROCKWOOL - mineral wool with fire-resistant coating and fire-resistant board

EI 90 (v_e i↔o) S

- For connection of following duct → see page 78
- Minimum and maximum distance between the wall and fire damper is unlimited
- When installing the insulation, follow the ROCKWOOL manufacturer's instructions
- The damper and the duct must be suspended separately
- The duct must be suspended on both sides of damper acc. to national rules
- Duct between fire damper and fire separating construction must be suspended by using threaded rods and mounting profiles, or another mounting system acc. to national standards
- Load of the suspension system depends on weight of the fire damper and duct system → see page 74
- Max. distance between two suspension systems is 1500 mm
- Duct at the point of penetration must be fixed to the fire separation structure
- Following air-conditioning duct must be suspended or supported so that all load transfer from the following duct to the fire damper is absolutely excluded. Adjacent duct must be suspended or supported, as required by the duct suppliers
- If the threaded rod is located inside the duct insulation, distance between threaded rod and duct is max 30 mm
- If the threaded rod is located outside the duct isolation, distance between threaded rod and isolation is max. 40 mm
- If the damper is installed outside the fire separation construction and a damper side A ≥ 800 mm, VRM-Q reinforcement frame must be used → see page 86

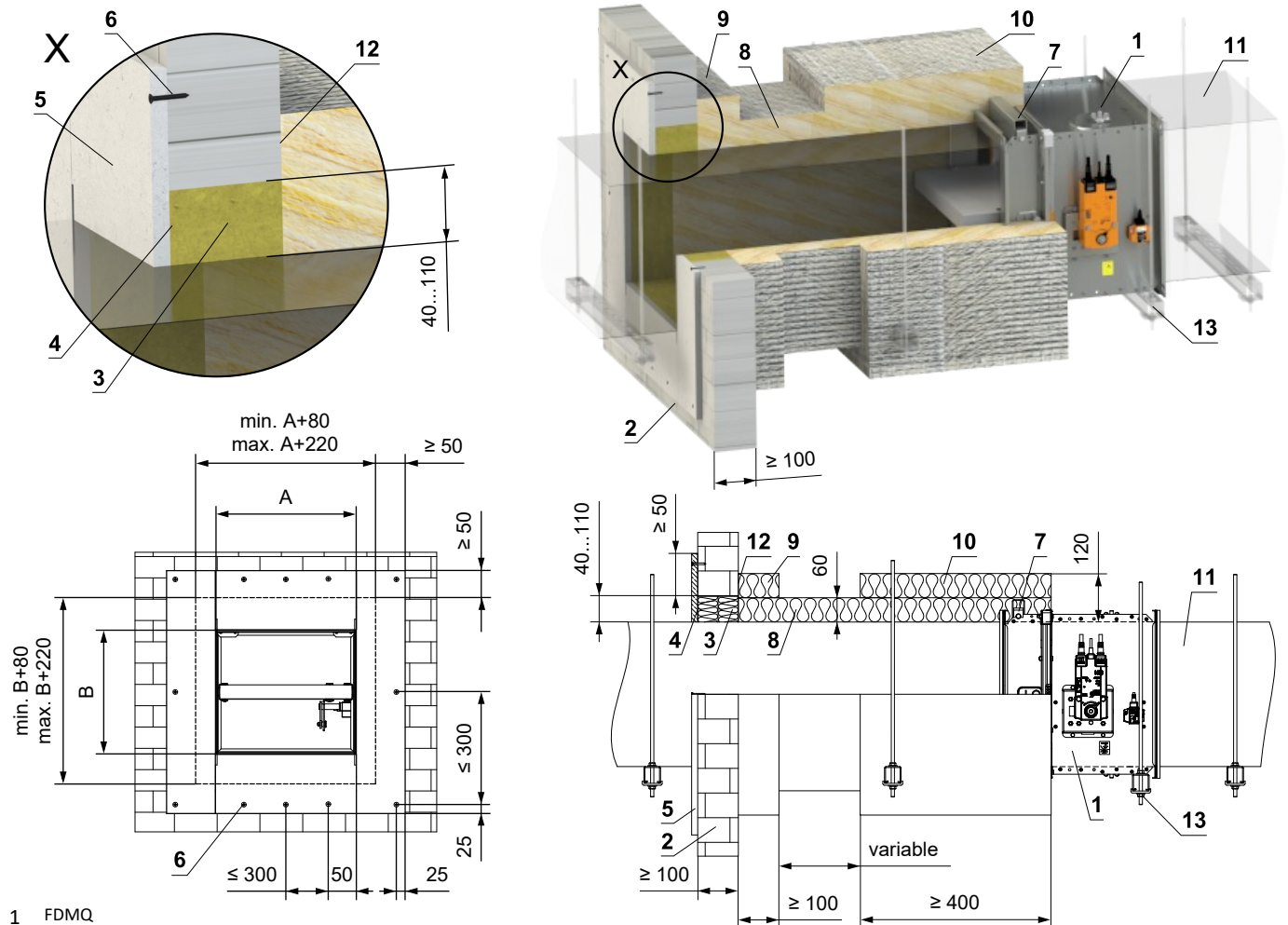

- | | |
|--|---|
| <ol style="list-style-type: none"> 1 FDMQ 2 Solid wall construction 3 Mineral wool board - min. density 140 kg/m³ (e.g. PROMAPYR-T150, ROCKWOOL HARDROCK / STEPROCK HD) 4 Fire-resistant coating - th. 1 mm (e.g. PROMASTOP-I) 5 Fire-resistant board - min. th. 15 mm, min. density 870 kg/m³ (e.g. PROMATECT-H) 6 Screw 4x50 mm - screws must be fixed in the wall construction, use steel anchors if necessary 7 VRM-Q → see page 86 8 Insulation board made of mineral wool, with a surface treatment of aluminum foil - th. 60 mm, min. density 300 kg/m³ - (System ROCKWOOL Conlit Ductrock 90) | <ol style="list-style-type: none"> 9 Duct penetration insulation collar - th. 60 mm (System ROCKWOOL Conlit Ductrock 90) - glued (pos. 12) and fixed with screws to the wall construction 10 Insulation collar of the damper and duct connection - th. 60 mm (System ROCKWOOL Conlit Ductrock 90) 11 Standard air duct made of galvanized sheet metal, thickness according to damper size – the duct must be anchored on both sides of the fire-separating structure, e.g. using L-profiles 30 × 30 × 3 mm – according to the ISOVER manufacturer's instructions 12 ROCKWOOL Firepro glue - apply on the insulation and fix it to the fire separation construction 13 Profile with threaded rod → see pages 74 to 77 |
|--|---|

In gypsum wall construction

In gypsum wall construction - mortar or gypsum

EI 90 (v_e i↔o) S

- For connection of following duct → see page 78
- The installation opening is lined with a UW/CW profile.

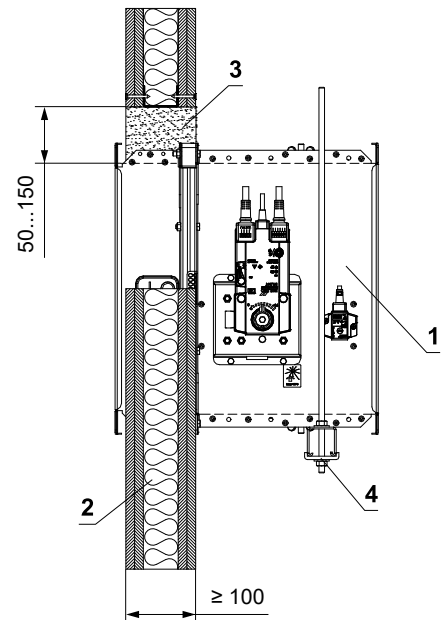
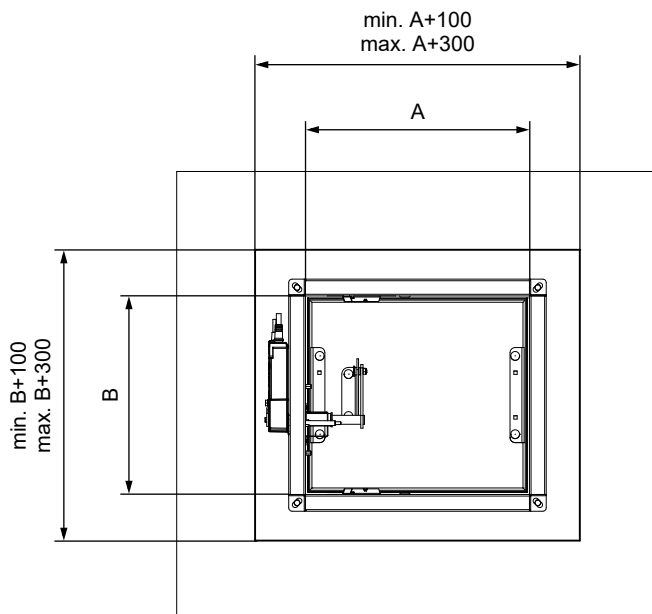
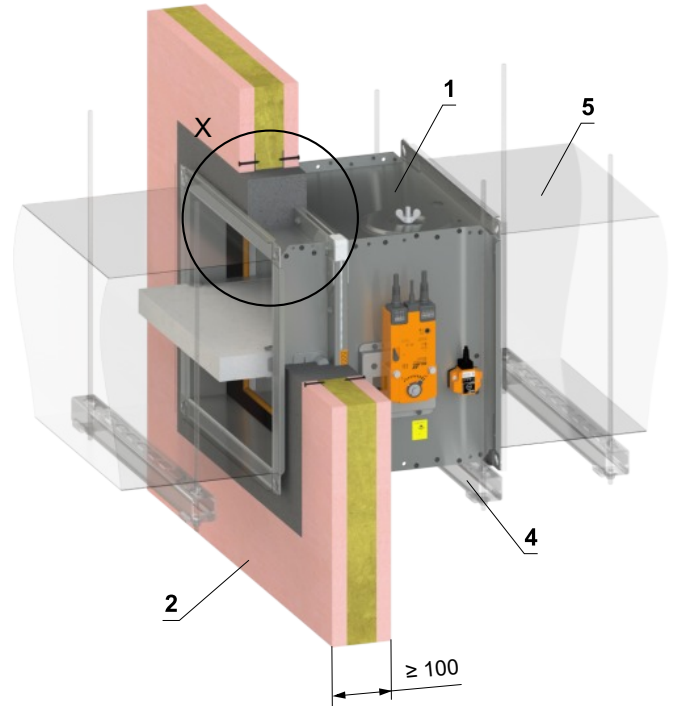
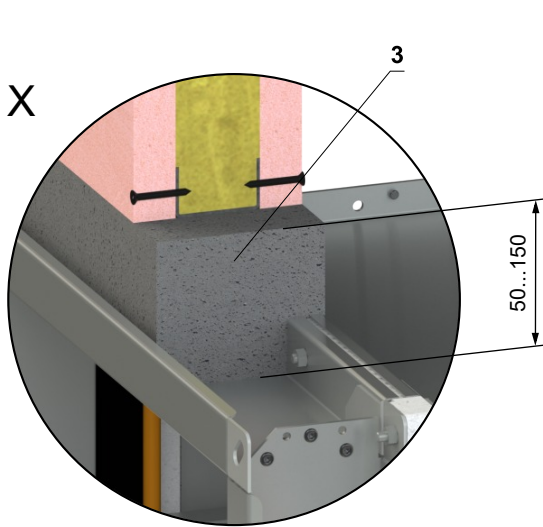

- 1 FDMQ
- 2 Gypsum wall construction
- 3 Mortar or gypsum
- 4 Profile with threaded rod → see pages 74 to 77
- 5 Duct

In gypsum wall construction - 2 dampers in battery - mortar or gypsum

EI 90 (v_e i↔o) S

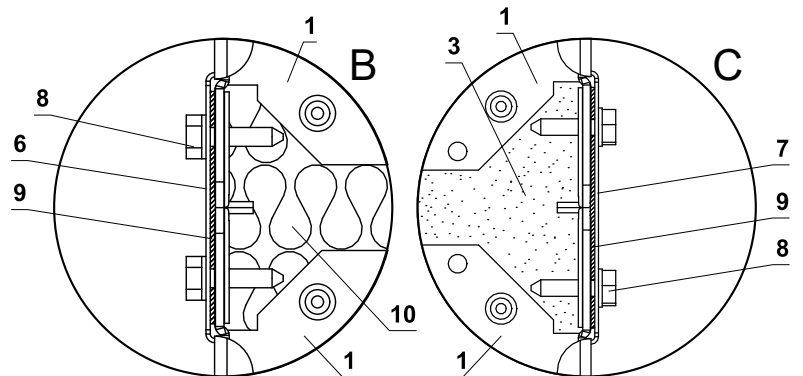
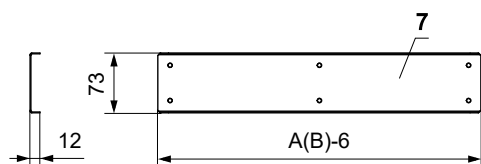
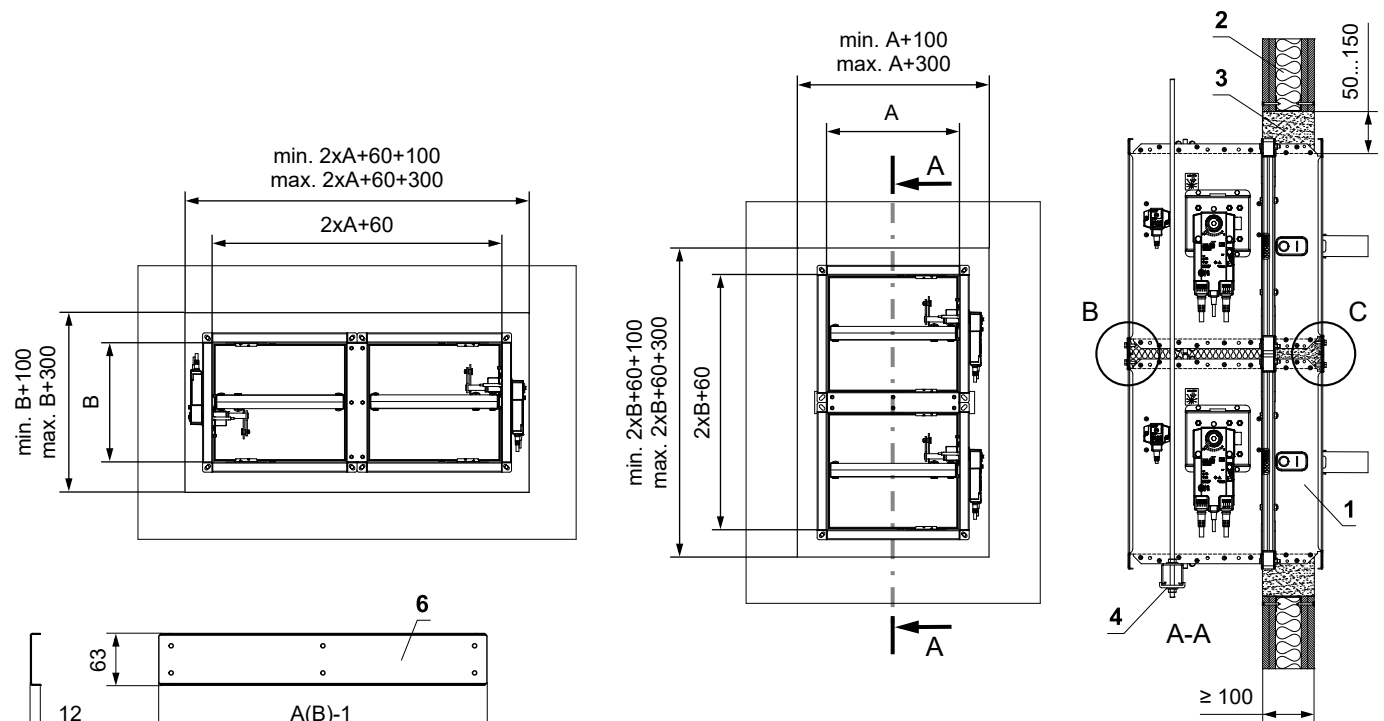
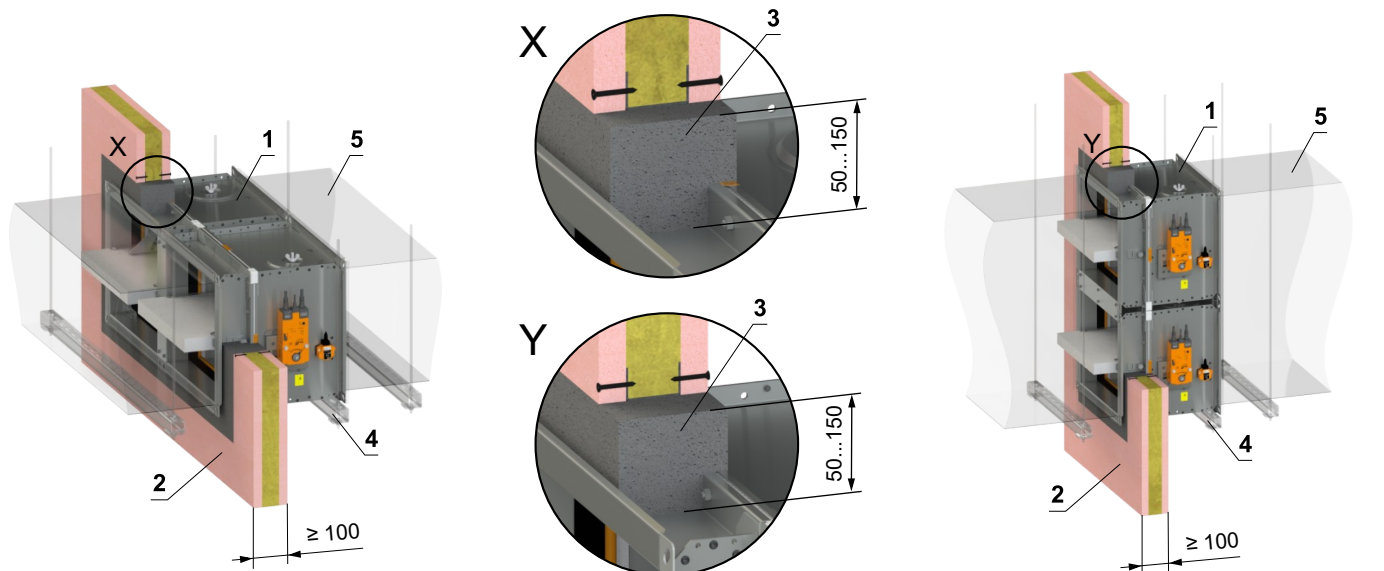

- 1 FDMQ
- 2 Gypsum wall construction
- 3 Mortar or gypsum
- 4 Profile with threaded rod → see pages 74 to 77
- 5 Duct
- 6 U-profile type 3
- 7 U-profile type 1
- 8 Screw TEX 4,8x18 mm (pitch ≤ 200 mm)
- 9 Sealing
- 10 Insulation board made of mineral wool - recommended for easy filling of gap with mortar/gypsum.

- For connection of following duct → see page 78
- The gap between the damper and construction is filled with mortar or gypsum
- The installation opening is lined with a UW/CW profile.

In gypsum wall construction - 4 dampers in battery - mortar or gypsum

EI 90 (v_e i↔o) S

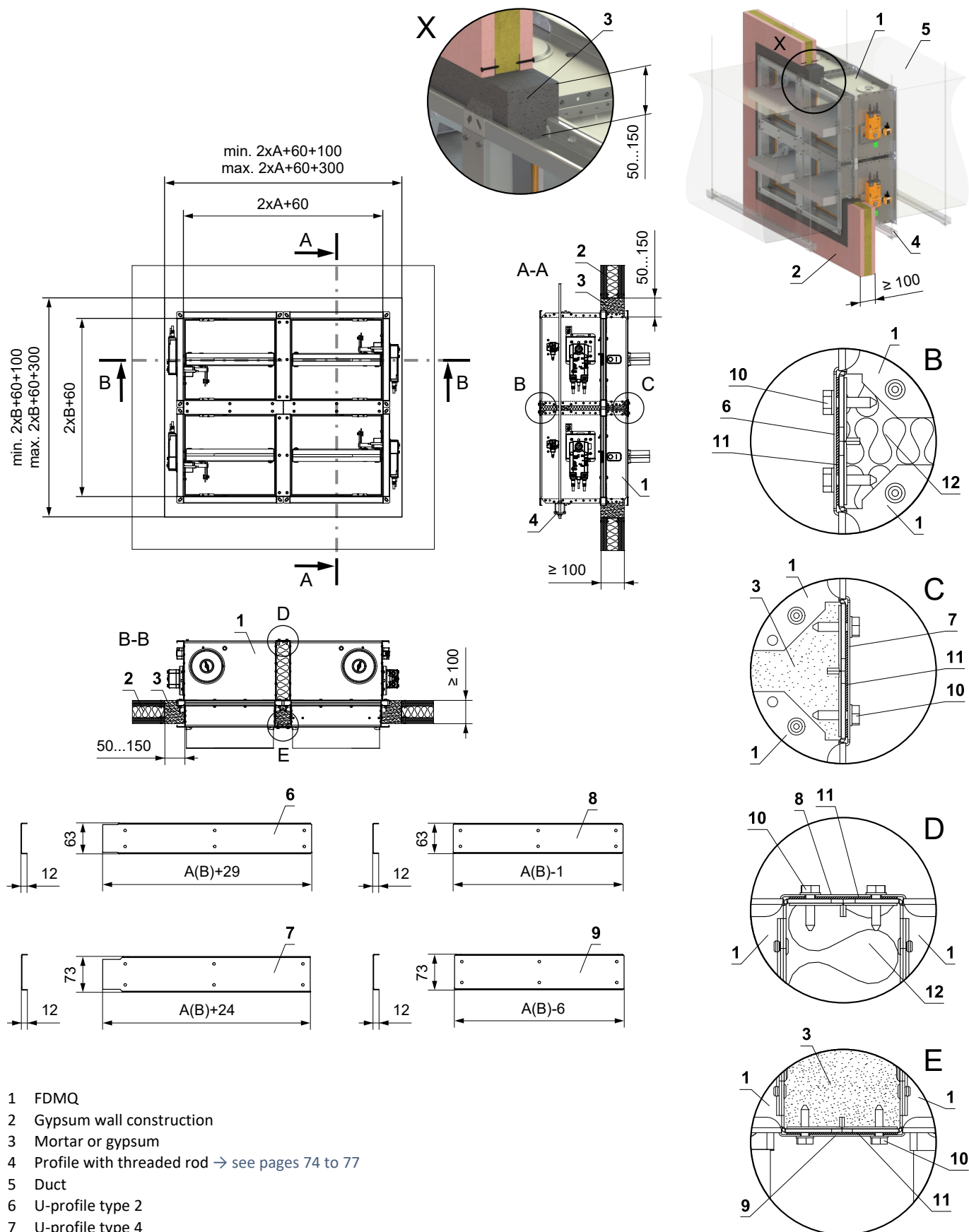

- 1 FDMQ
- 2 Gypsum wall construction
- 3 Mortar or gypsum
- 4 Profile with threaded rod → see pages 74 to 77
- 5 Duct
- 6 U-profile type 2
- 7 U-profile type 4
- 8 U-profile type 1
- 9 U-profile type 3
- 10 Screw TEX 4,8x18 mm (pitch ≤ 200 mm)
- 11 Sealing
- 12 Insulation board made of mineral wool - recommended for easy filling of gap with mortar/gypsum.

- For connection of following duct → see page 78
- The gap between the damper and construction is filled with mortar or gypsum
- The installation opening is lined with a UW/CW profile.

In gypsum wall construction - Ablative Coated Batt

EI 90 (v_e i↔o) S

- For connection of following duct → see page 78
- The installation opening is lined with a UW/CW profile.

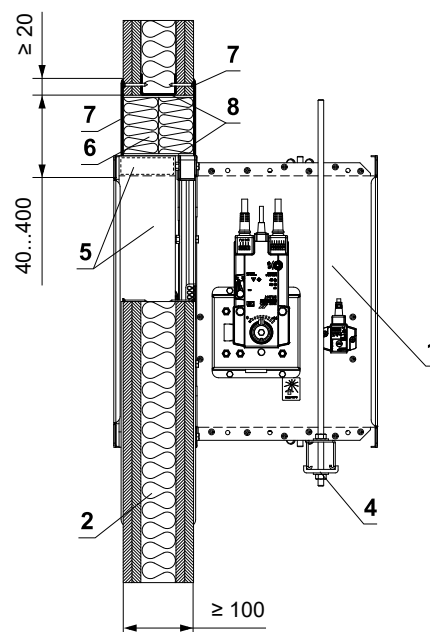
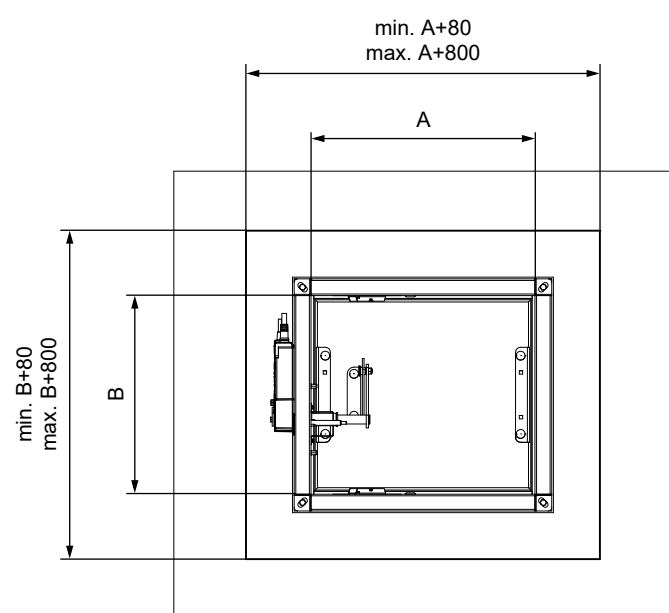
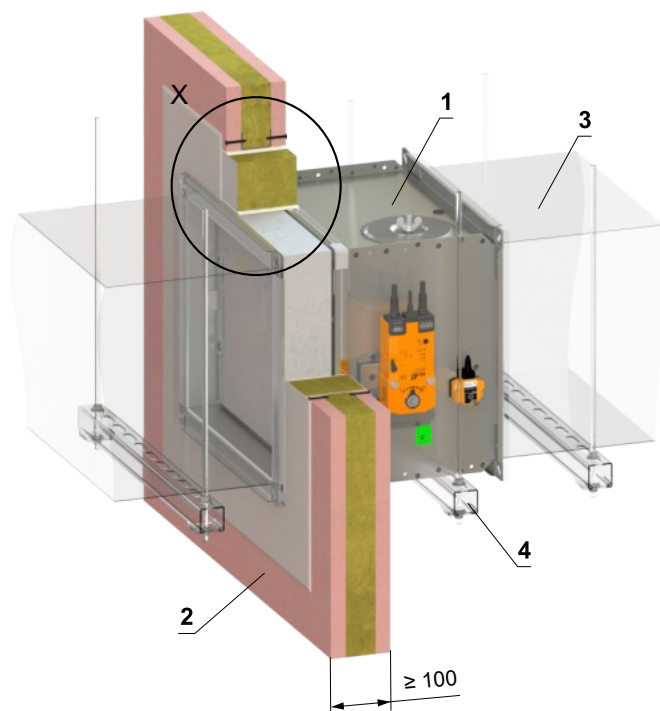
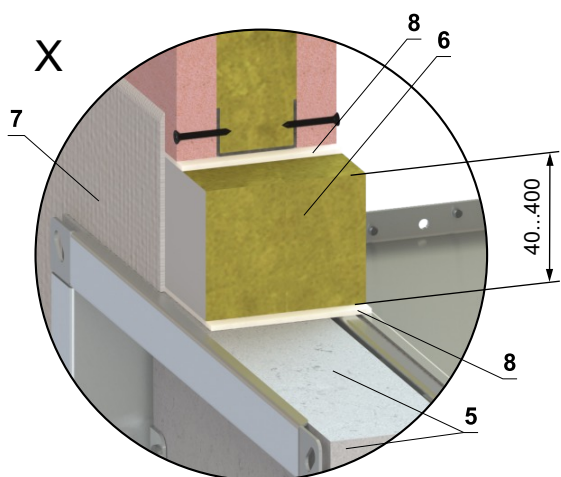

- 1 FDMQ
- 2 Gypsum wall construction
- 3 Duct
- 4 Profile with threaded rod → see pages 74 to 77
- 5 Protective cladding board - min. th. 30 mm, min. density 750 kg/m³ (e.g. PROMATECT-MST) → see page 87
Ablative Coated Batt System HILTI*
- 6 Mineral wool board - min. density 140 kg/m³ (HILTI CFS-CT B 1S 140/50...)
- 7 Fire stop coating - th. 1 mm (HILTI CFS-CT...) - coating is overcoated on the support construction and on the damper casing/duct
- 8 Fire-resistant mastic - (HILTI CFS-S ACR...) fill the gap from both sides of the fire separation construction and around the perimeter of penetration and damper casing

* HILTI system can be replaced by a similar system with the same or higher thickness, density, fire reaction class, tested according to EN 1366-3.

In gypsum wall construction - mineral wool with fire-resistant coating and fire-resistance boards

EI 90 (v_e i↔o) S

- For connection of following duct → see page 78
- The installation opening is lined with a UW/CW profile.

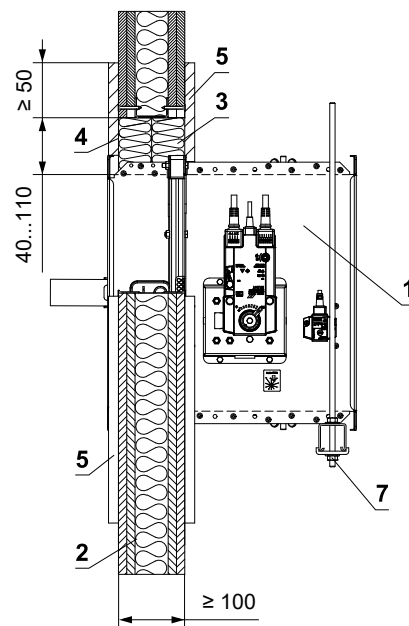
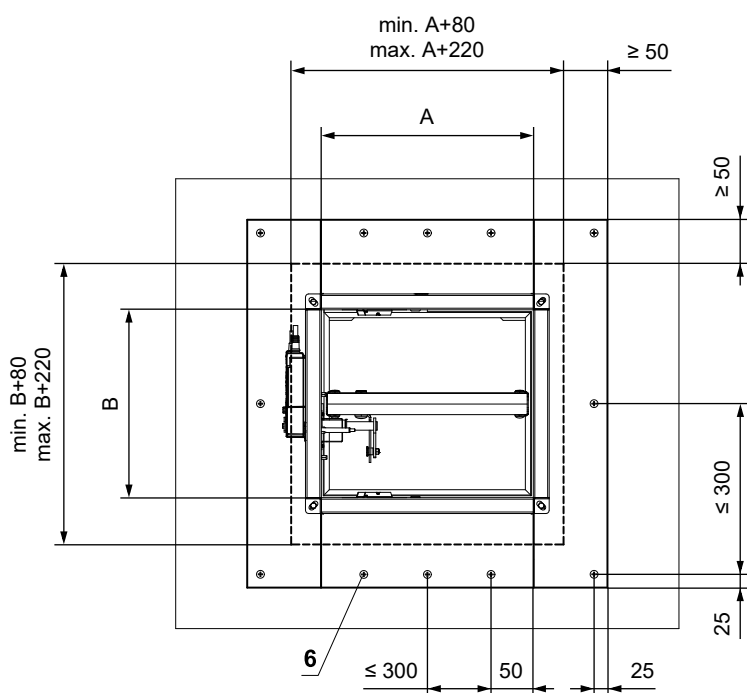
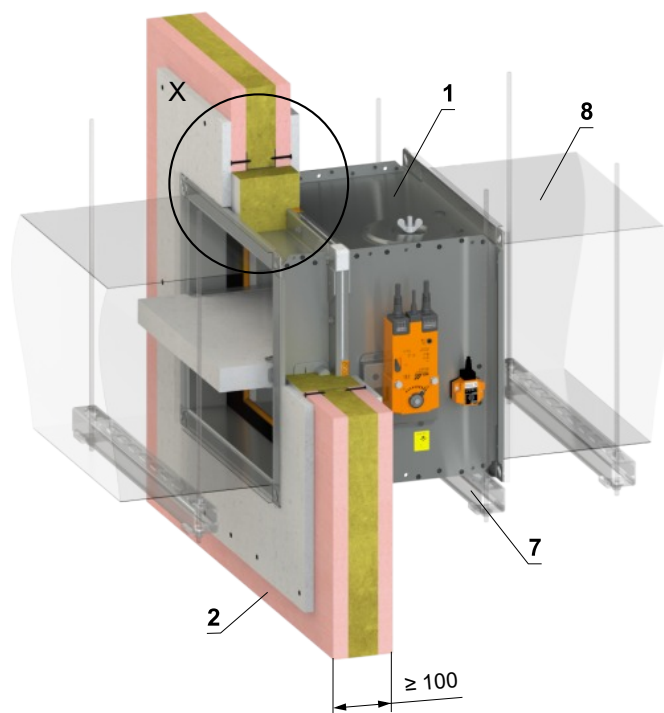
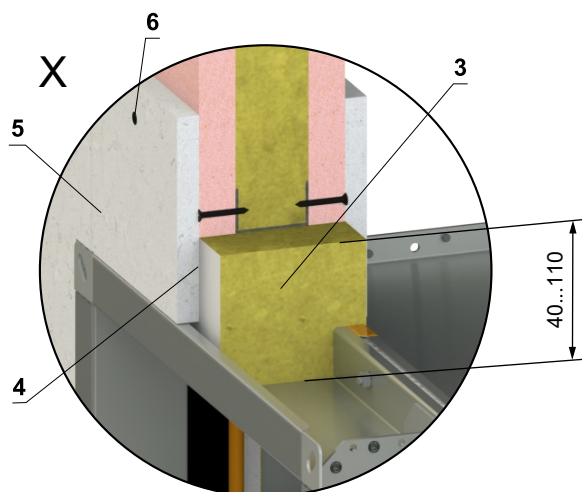

- 1 FDMQ
- 2 Gypsum wall construction
- 3 Mineral wool board - min. density 140 kg/m³ (e.g. PROMAPYR-T150, ROCKWOOL HARDROCK / STEPROCK HD)
- 4 Fire-resistant coating - th. 1 mm (e.g. PROMASTOP-I)
- 5 Fire-resistant board - min. th. 15 mm, min. density 870 kg/m³ (e.g. PROMATECT-H)
- 6 Screw 4x50 mm - screws must be fixed in the wall construction, use steel anchors if necessary
- 7 Profile with threaded rod → see pages 74 to 77
- 8 Duct

In gypsum wall construction - installation next to the wall/ceiling - mortar or gypsum + mineral wool EI 90 (v_e i↔o) S

- For connection of following duct → see page 78
- Conditions of this installation are also valid for the installation in **Solid ceiling construction**
- Penetration is filled with mortar or gypsum + mineral wool (shape, according to the location of the damper). Fix the mineral wool with glue (e.g. Promat K84 or equivalent) to the construction and damper casing
- The installation opening is lined with a UW/CW profile.

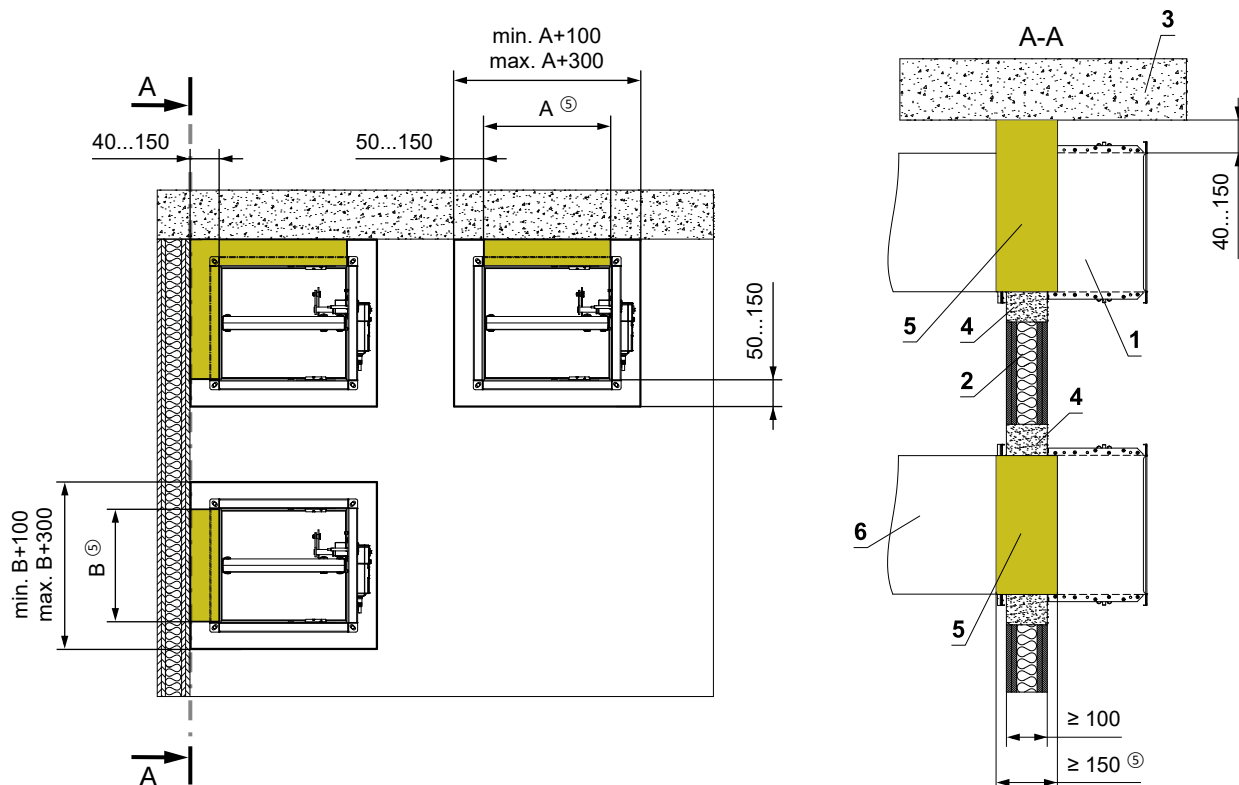
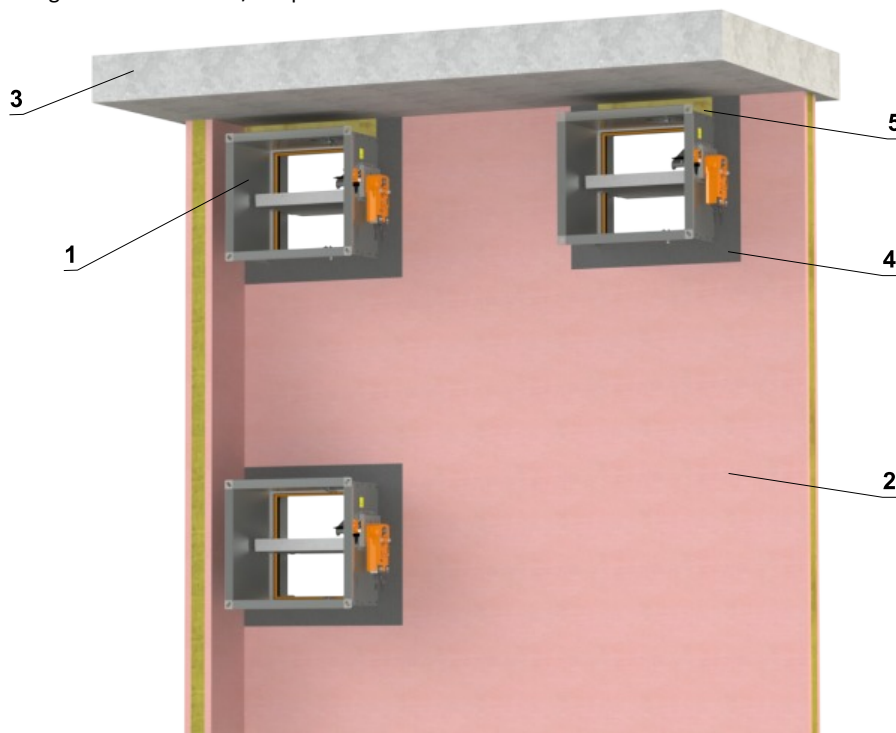

- 1 FDMQ
- 2 Gypsum wall construction
- 3 Solid ceiling construction
- 4 Mortar or gypsum
- 5 Mineral wool board - min. density 140 kg/m³ (e.g. PROMAPYR-T150, ROCKWOOL HARDROCK / STEPLOCK HD)
- 6 Duct

Installation outside gypsum wall construction

Outside gypsum wall construction - ISOVER Ultimate Protect - mortar or gypsum

EI 60 (v_e i↔o) S

- For connection of following duct → see page 78
- Minimum and maximum distance between the wall and fire damper is unlimited
- When installing the insulation, follow the ISOVER manufacturer's instructions
- The damper and the duct must be suspended separately
- The duct must be suspended on both sides of damper acc. to national rules
- Duct between fire damper and fire separating construction must be suspended by using threaded rods and mounting profiles, or another mounting system acc. to national standards
- Load of the suspension system depends on weight of the fire damper and duct system → see page 74
- Max. distance between two suspension systems is 1500 mm
- Following air-conditioning duct must be suspended or supported so that all load transfer from the following duct to the fire damper is absolutely excluded. Adjacent duct must be suspended or supported, as required by the duct suppliers
- If the threaded rod is located inside the duct insulation, distance between threaded rod and duct is max 30 mm
- If the threaded rod is located outside the duct isolation, distance between threaded rod and isolation is max. 40 mm
- The installation opening is lined with a UW/CW profile.

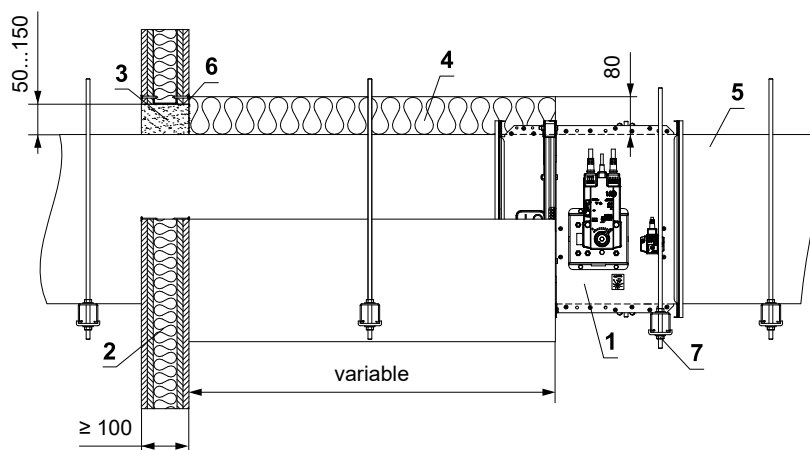
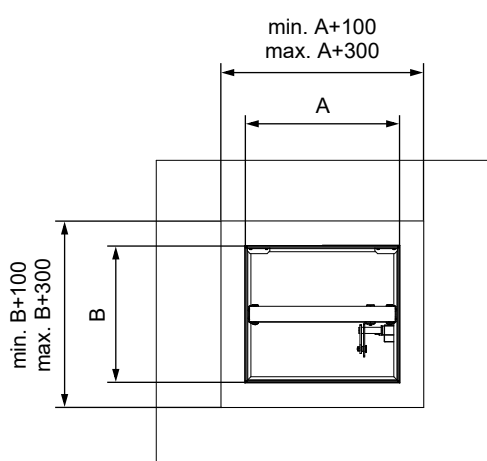
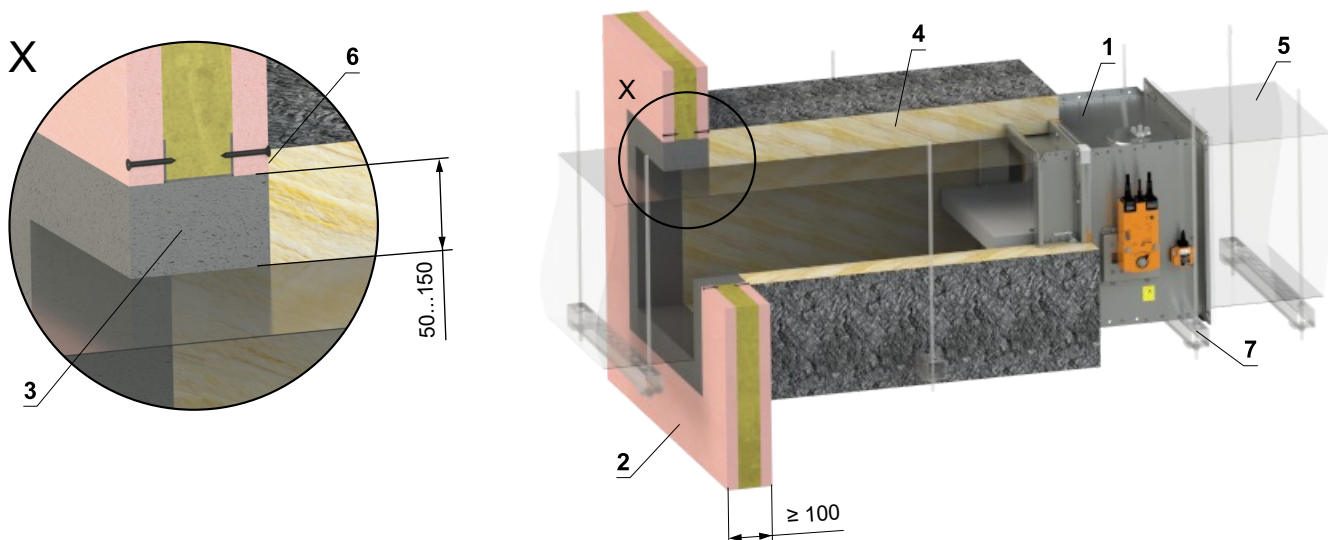

- 1 FDMQ
- 2 Gypsum wall construction
- 3 Mortar or gypsum
- 4 Insulation board made of mineral wool, with a surface treatment of aluminum foil, min. thickness 80 mm, min. density 66 kg/m³ (System ISOVER Ultimate Protect Wired Mat 4.0 Alu1)
- 5 Standard air duct, made of galvanized sheet metal min. thickness 0,8 mm – the duct must be anchored on both sides of the fire-separating structure, e.g. using L-profiles 30 × 30 × 3 mm – according to the ISOVER manufacturer's instructions
- 6 ISOVER Protect BSK glue - apply on the insulation and fix it to the fire separation construction
- 7 Profile with threaded rod → see pages 74 to 77

Outside gypsum wall construction - ISOVER Ultimate Protect - Ablative Coated Batt

EI 60 (v_e i↔o) S

- For connection of following duct → see page 78
- Minimum and maximum distance between the wall and fire damper is unlimited
- When installing the insulation, follow the ISOVER manufacturer's instructions
- The damper and the duct must be suspended separately
- The duct must be suspended on both sides of damper acc. to national rules
- Duct between fire damper and fire separating construction must be suspended by using threaded rods and mounting profiles, or another mounting system acc. to national standards
- Load of the suspension system depends on weight of the fire damper and duct system → see page 74
- Max. distance between two suspension systems is 1500 mm
- Following air-conditioning duct must be suspended or supported so that all load transfer from the following duct to the fire damper is absolutely excluded. Adjacent duct must be suspended or supported, as required by the duct suppliers
- If the threaded rod is located inside the duct insulation, distance between threaded rod and duct is max 30 mm
- If the threaded rod is located outside the duct isolation, distance between threaded rod and isolation is max. 40 mm
- The installation opening is lined with a UW/CW profile.

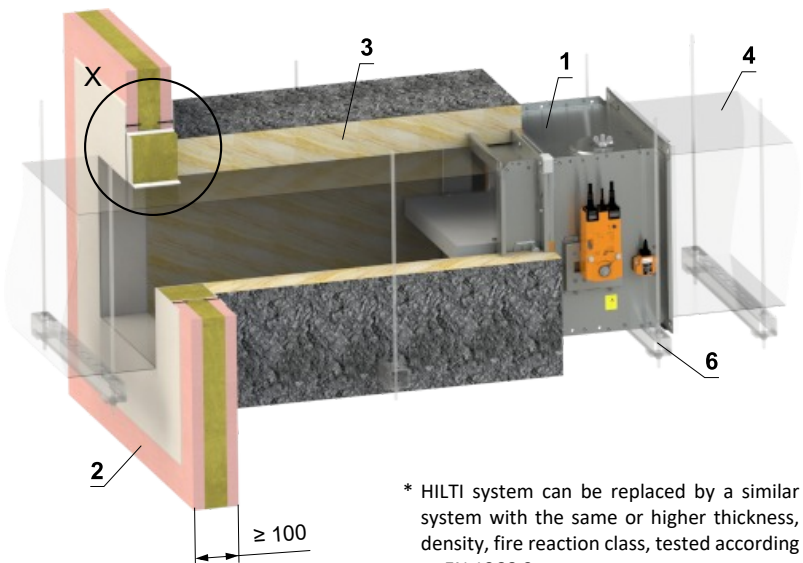
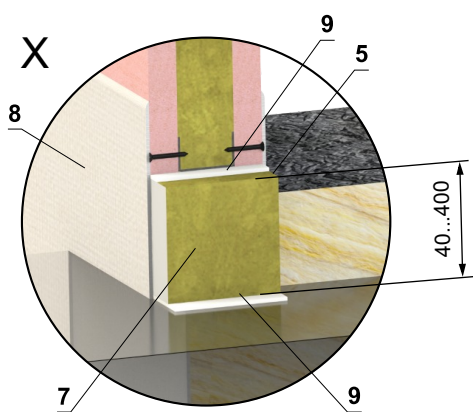

* HILTI system can be replaced by a similar system with the same or higher thickness, density, fire reaction class, tested according to EN 1366-3.

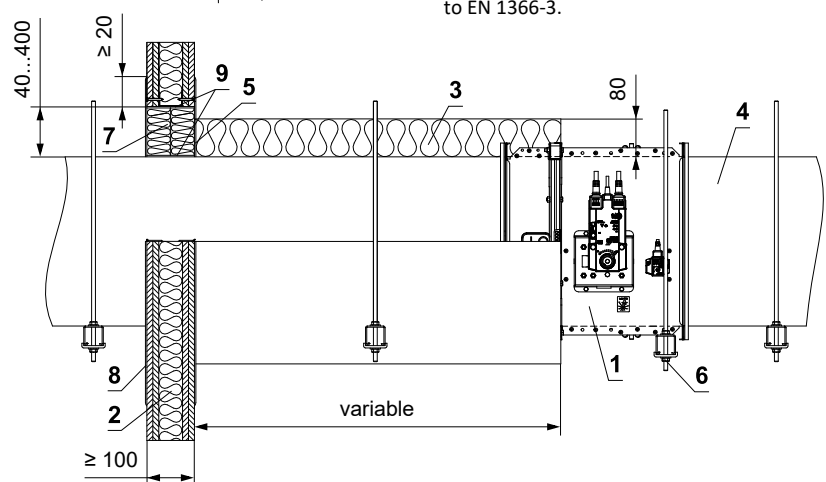
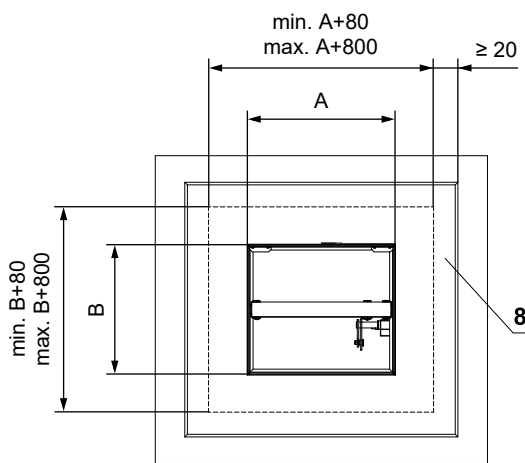

- 1 FDMQ
- 2 Gypsum wall construction
- 3 Insulation board made of mineral wool, with a surface treatment of aluminum foil, min. thickness 80 mm, min. density 66 kg/m³ (System ISOVER Ultimate Protect Wired Mat 4.0 Alu1)
- 4 Standard air duct, made of galvanized sheet metal min. thickness 0,8 mm – the duct must be anchored on both sides of the fire-separating structure, e.g. using L-profiles 30 × 30 × 3 mm – according to the ISOVER manufacturer's instructions
- 5 ISOVER Protect BSK glue - apply on the insulation and fix it to the fire separation construction
- 6 Profile with threaded rod → see pages 74 to 77
Ablative Coated Batt System HILTI*
- 7 Mineral wool board - min. density 140 kg/m³ (HILTI CFS-CT B 1S 140/50...)
- 8 Fire stop coating - th. 1 mm (HILTI CFS-CT...) - coating is overcoated on the support construction and on the damper casing/duct
- 9 Fire-resistant mastic - (HILTI CFS-S ACR...) fill the gap from both sides of the fire separation construction and around the perimeter of penetration and damper casing

Outside gypsum wall construction - mineral wool ROCKWOOL - mineral wool with fire-resistant coating and fire-resistant board EI 90 (v_e i↔o) S

- For connection of following duct → see page 78
- Minimum and maximum distance between the wall and fire damper is unlimited
- When installing the insulation, follow the ROCKWOOL manufacturer's instructions
- The damper and the duct must be suspended separately
- The duct must be suspended on both sides of damper acc. to national rules
- Duct between fire damper and fire separating construction must be suspended by using threaded rods and mounting profiles, or another mounting system acc. to national standards
- Load of the suspension system depends on weight of the fire damper and duct system → see page 74
- Max. distance between two suspension systems is 1500 mm
- Duct at the point of penetration must be fixed to the fire separation structure
- Following air-conditioning duct must be suspended or supported so that all load transfer from the following duct to the fire damper is absolutely excluded. Adjacent duct must be suspended or supported, as required by the duct suppliers
- If the threaded rod is located inside the duct insulation, distance between threaded rod and duct is max 30 mm
- If the threaded rod is located outside the duct isolation, distance between threaded rod and isolation is max. 40 mm
- If the damper is installed outside the fire separation construction and a damper side A ≥ 800 mm, VRM-Q reinforcement frame must be used → see page 86
- The installation opening is lined with a UW/CW profile.

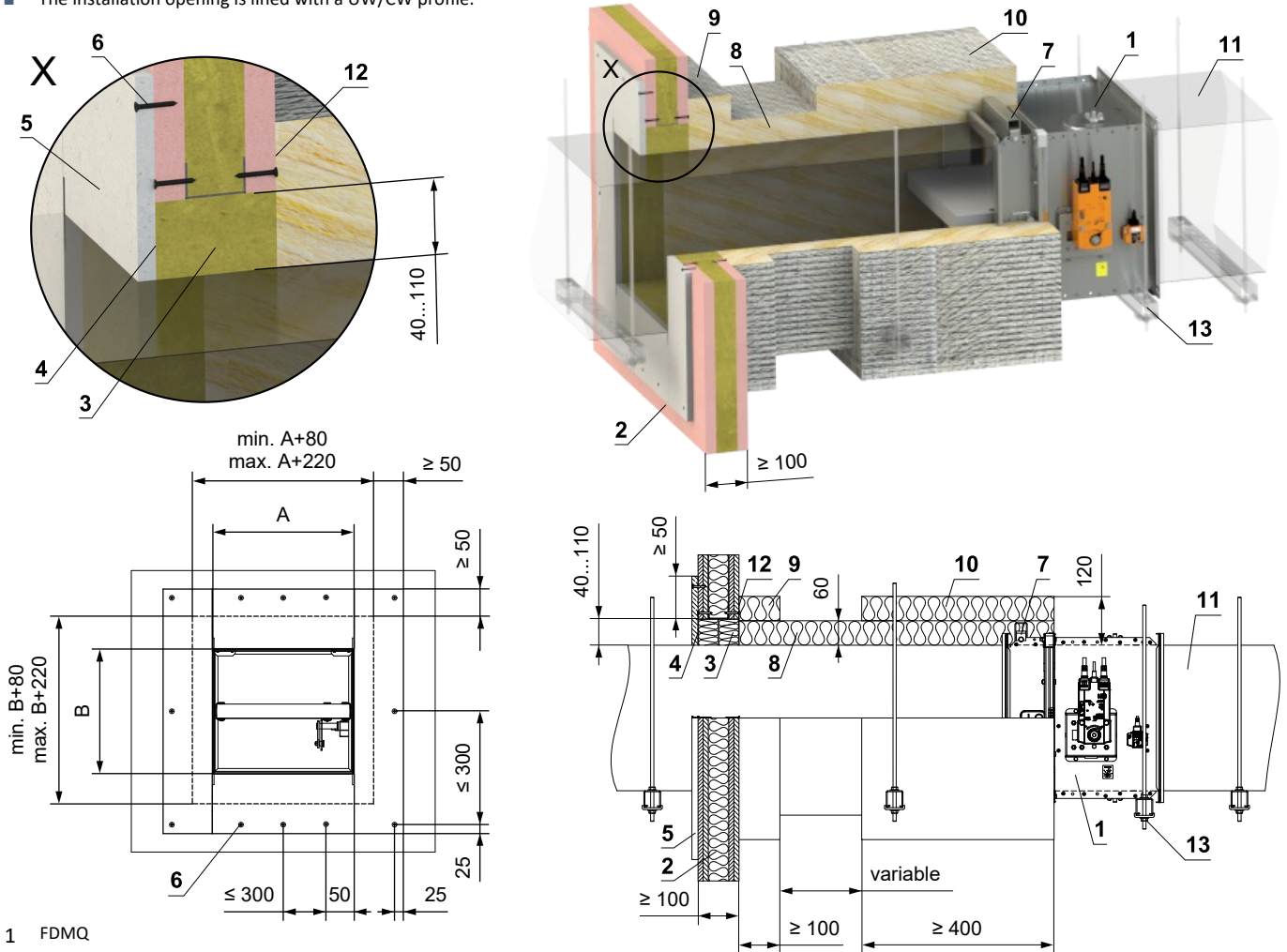

- 1 FDMQ
- 2 Gypsum wall construction
- 3 Mineral wool board - min. density 140 kg/m³ (e.g. PROMAPYR-T150, ROCKWOOL HARDROCK / STEPROCK HD)
- 4 Fire-resistant coating - th. 1 mm (e.g. PROMASTOP-I)
- 5 Fire-resistant board - min. th. 15 mm, min. density 870 kg/m³ (e.g. PROMATECT-H)
- 6 Screw 4x50 mm - screws must be fixed in the wall construction, use steel anchors if necessary
- 7 VRM-Q → see page 86
- 8 Insulation board made of mineral wool, with a surface treatment of aluminum foil - th. 60 mm, min. density 300 kg/m³ - (System ROCKWOOL Conlit Ductrock 90)
- 9 Duct penetration insulation collar - th. 60 mm (System ROCKWOOL Conlit Ductrock 90) - glued (pos. 12) and fixed with screws to the wall construction
- 10 Insulation collar of the damper and duct connection - th. 60 mm (System ROCKWOOL Conlit Ductrock 90)
- 11 Standard air duct, made of galvanized sheet metal min. thickness 0,8 mm – the duct must be anchored on both sides of the fire-separating structure, e.g. using L-profiles 30 × 30 × 3 mm – according to the ISOVER manufacturer's instructions
- 12 ROCKWOOL Firepro glue - apply on the insulation and fix it to the fire separation construction
- 13 Profile with threaded rod → see pages 74 to 77

Installation in sandwich wall construction

In sandwich wall construction - Ablative Coated Batt with fire-resistant boards

EI 90 (v_e i↔o) S

■ For connection of following duct → see page 78

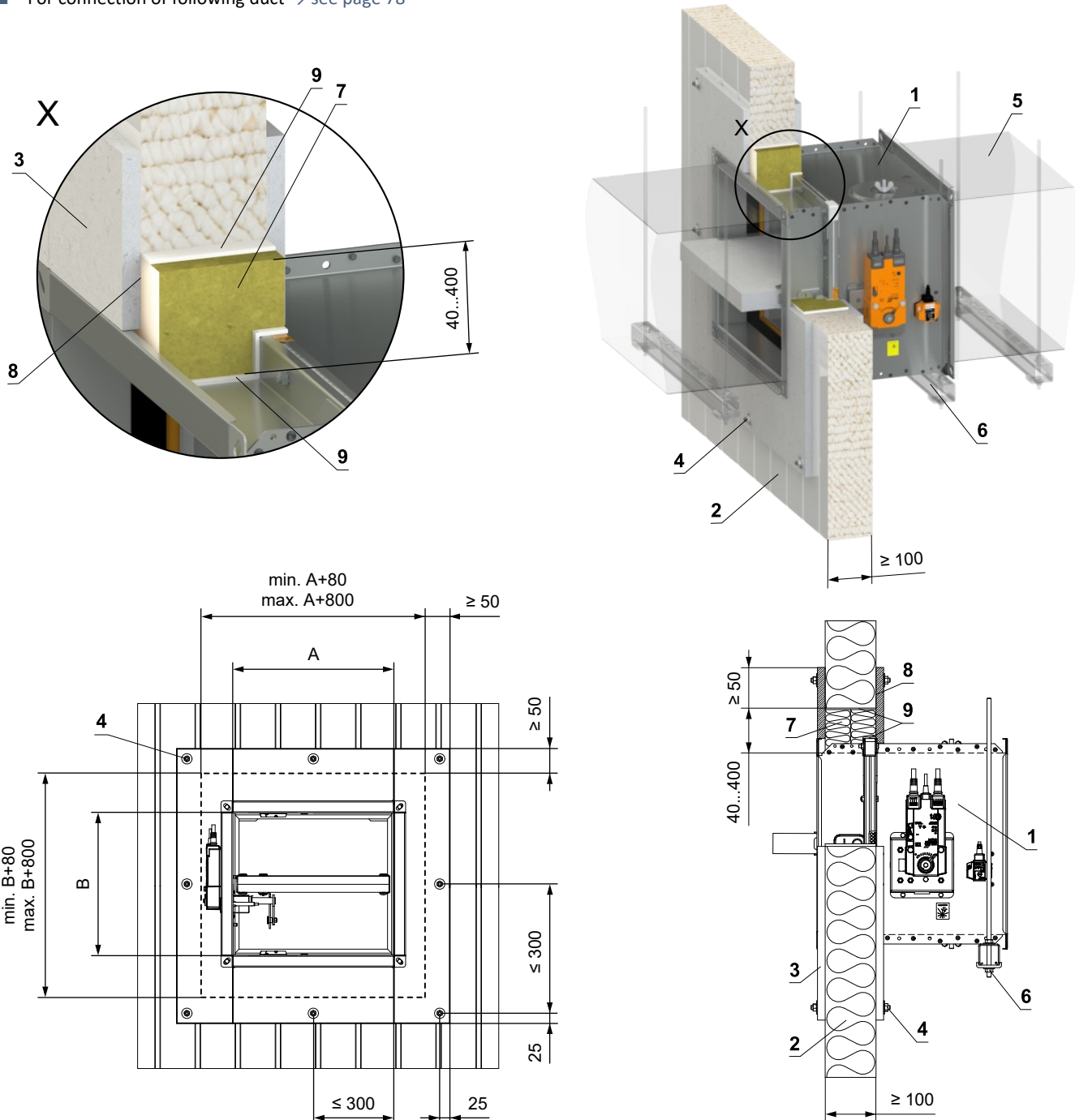

* HILTI system can be replaced by a similar system with the same or higher thickness, density, fire reaction class, tested according to EN 1366-3.

- 1 FDMQ
 - 2 Sandwich wall construction - min. th. 100 mm (Paroc AST S or RUUKKI SPB W)
 - 3 Fire-resistant board - min. th. 15 mm, min. density 870 kg/m³ (e.g. PROMATECT-H)
 - 4 Fixing connection of boards - threaded rod M8 (length of the threaded rod for 100 mm sandwich construction is approx. 150 mm, 2 pcs large washer M8, 2 pcs nut M8). The boards must be tightly fixed to the sandwich wall construction!
 - 5 Duct
 - 6 Profile with threaded rod → see pages 74 to 77
- Ablative Coated Batt System HILTI*
- 7 Mineral wool board - min. density 140 kg/m³ (HILTI CFS-CT B 1S 140/50...)
 - 8 Fire stop coating - th. 1 mm (HILTI CFS-CT...) - coating is overcoated on the support construction and on the damper casing/duct
 - 9 Fire-resistant mastic - (HILTI CFS-S ACR...) fill the gap from both sides of the fire separation construction and around the perimeter of penetration and damper casing

Shaft walls

Rigips

- Shaft wall is a vertical, non-bearing partition construction meeting the double-sided fire requirements. The shaft wall can be mounted only from one side. No mineral insulation is used in the construction.
- First of all, the shaft wall construction must be laid out. Apart from other vertical constructions, the perimeter sections must be fitted with connection sealing made from A1 or A2 fire reaction materials (for instance floor strips Orsil N/PP). The perimeter sections must be anchored using steel plugs \varnothing 6 mm (for example DN6 or ZHOP) with 500 mm span.
- Sheathing is carried out using two layers of Glasroc F boards Ridurit with 20 mm thickness, the boards are oriented horizontally. First sheathing layer is fixed with TN 212 screws in spacing 200mm to the support construction. The boards are mounted to tight butt joints without need of cementing. The second sheathing layer is screwed to the first sheathing layer using screws Rodurit in square net 250 mm. Reset of joints of the first and second layer of Ridurit sheathing is set to 600 mm vertically and 300 mm horizontally.

Assembly with support structure

- Vertical intermediate R-CW sections are fixed in 1000 mm layout spacing between R-UW sections and vertical perimeter R-CW sections.

Assembly without support structure

- Maximum width of the shaft wall is 2 metres in this case (board length). Steel squares made from steel galvanized sheet metal 40/20/1 mm are used as perimeter sections, they are anchored to bearing wall using \varnothing 6 mm steel plugs (for example DN6 or ZHOP) with 500 mm spacing.

Assembly with support structure

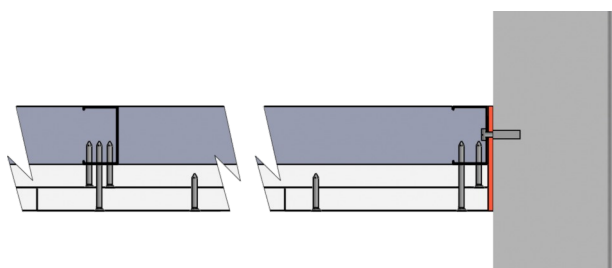

Assembly without support structure

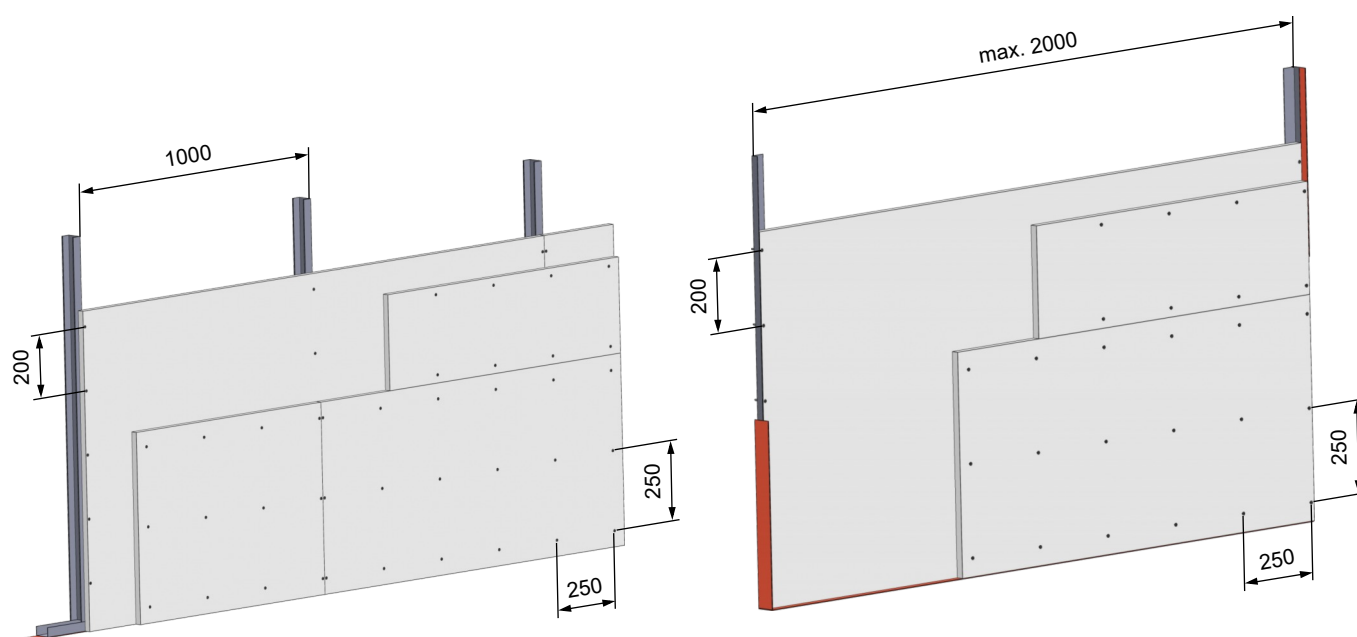
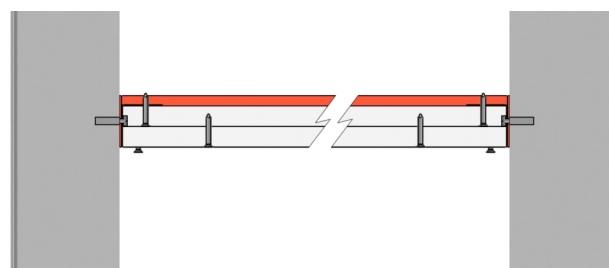

- Rigips solution is shown here as an example. Alternatively it is possible to apply the solution from Knauf or Promat. In such a case follow the instructions of the producer.

In shaft wall Rigips - mortar or gypsum

EI 90 (v_e i↔o) S

- For connection of following duct → see page 78
- Follow shaft wall manufacturer's instructions
- All technical specifications and conditions can be found at www.rigips.cz

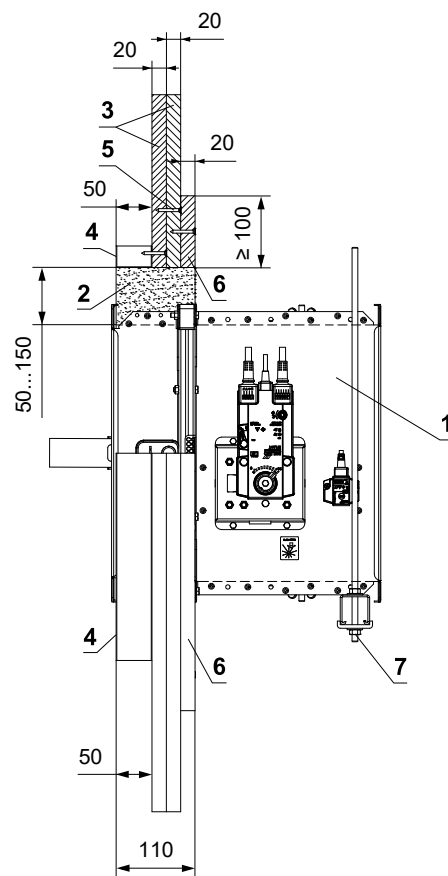
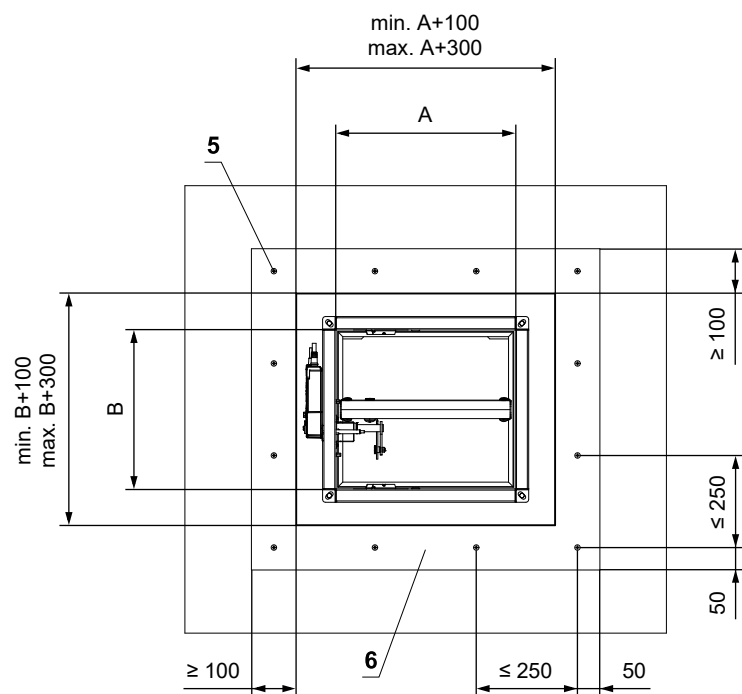
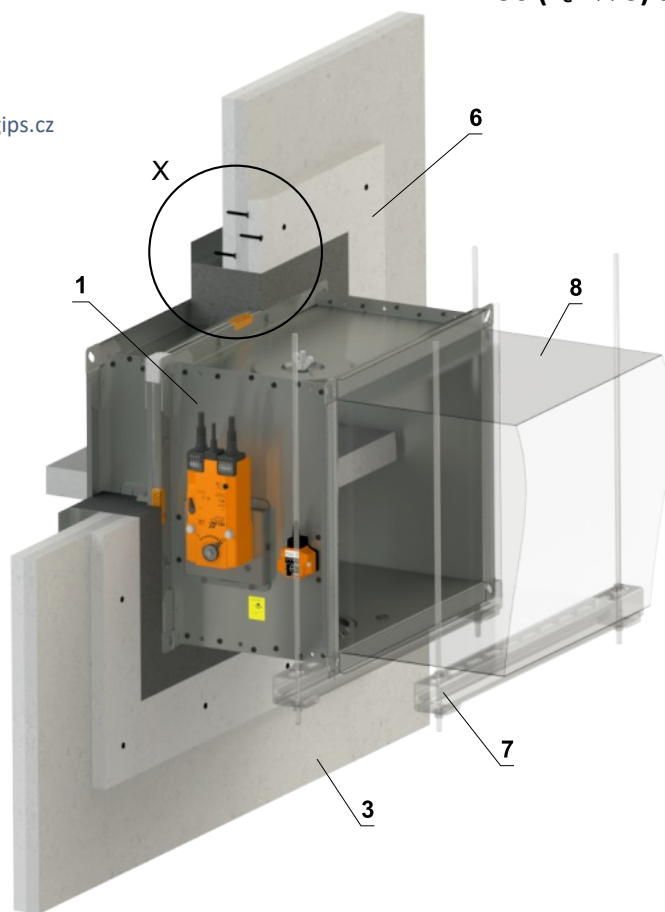
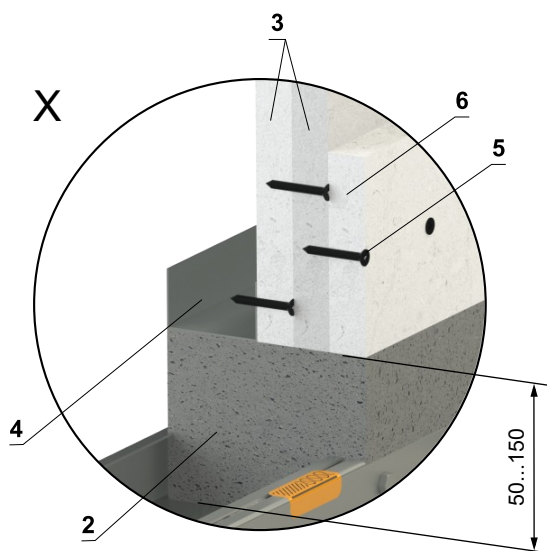

- 1 FDMQ
- 2 Mortar or gypsum
- 3 Fire-resistant board th. 20 mm Rigips Glasroc F Ridurit
- 4 Steel U-profile Rigips R-UW 50 or Rigips R-CW 50
- 5 Screw Rigips Ridurit TX 3,5x35 mm
- 6 Additional fire-resistant board tl. 20 mm Rigips Glasroc F Ridurit
- 7 Profile with threaded rod → see pages 74 to 77
- 8 Duct

In shaft wall Rigips - installation frame E1

EI 90 (v_e i↔o) S

- For connection of following duct → see page 78
- Follow shaft wall manufacturer's instructions
- All technical specifications and conditions can be found at www.rigips.cz
- Installation frame can be installed on the damper or delivered separately
- For more E1 frame details → see page 55

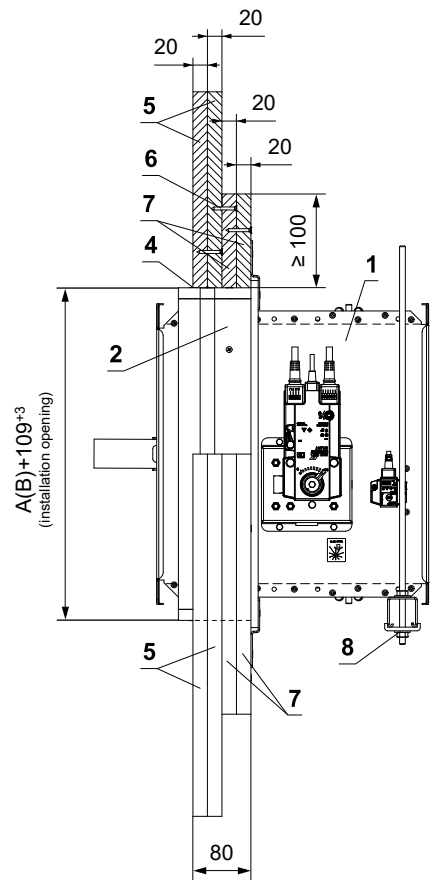
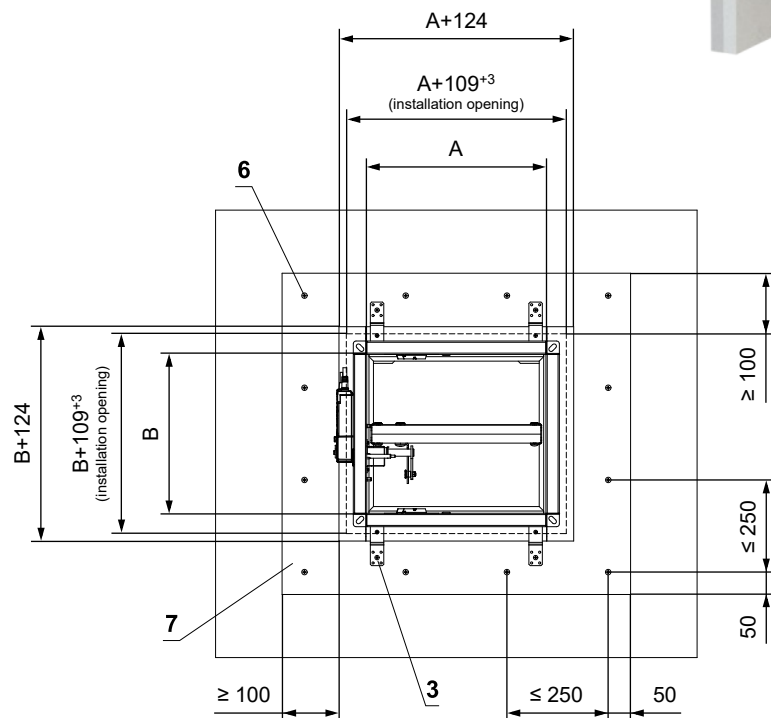
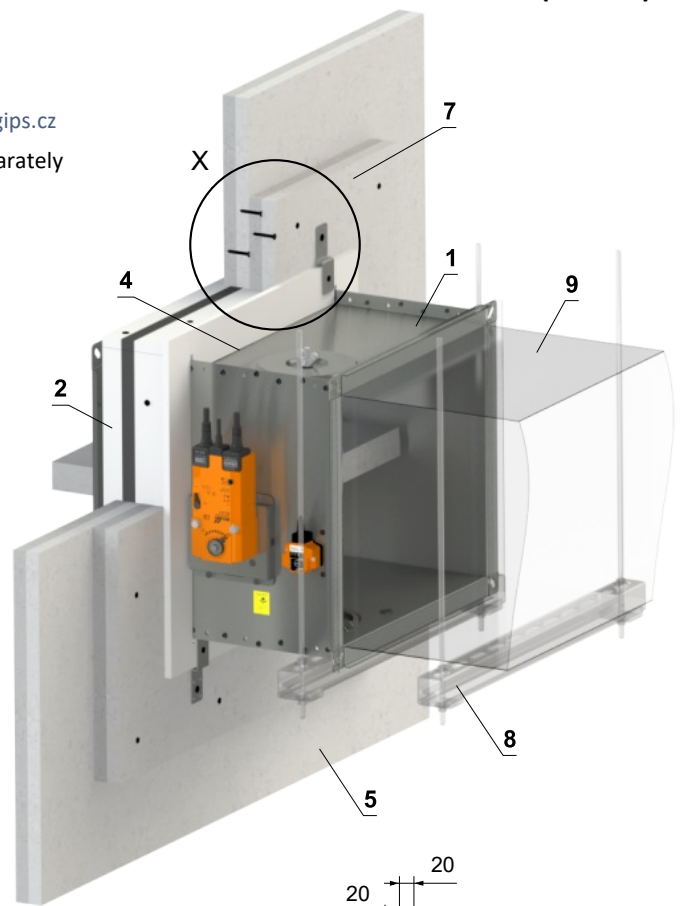
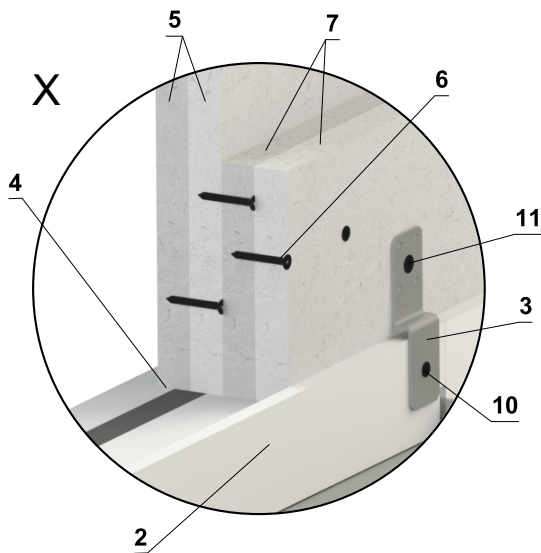

- 1 FDMQ
- 2 Installation frame E1
- 3 Bracket (fastening material included in frame delivery)
- 4 Fill the gaps with glue PROMAT K84
- 5 Fire-resistant board th. 20 mm Rigips Glasroc F Ridurit
- 6 Screw Rigips Ridurit TX 3,5x35 mm
- 7 Additional fire-resistant board th. 20 mm Rigips Glasroc F Ridurit
- 8 Profile with threaded rod → see pages 74 to 77
- 9 Duct
- 10 Screw 4x16 mm to attach bracket to the frame
- 11 Screw 5x60 mm to attach bracket to the construction

Number of brackets $X = ZA + ZB$ Number of screws $Y = 2 \times X$

Side A	Number of brackets ZA	Side B	Number of brackets ZB
$A \leq 500$	4	$B \leq 500$	0
$500 < A \leq 1000$	6	$500 < B \leq 800$	4
$1000 < A \leq 1500$	8		

In solid ceiling construction

In solid ceiling construction - mortar or gypsum

EI 90 (h_o i↔o) S

- For connection of following duct → see page 78
- The damper can be installed from both sides of the construction, i.e. from the top or the bottom side of the ceiling.

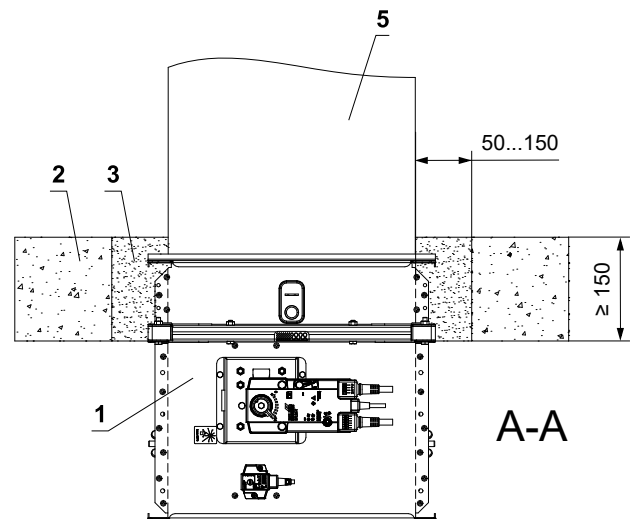
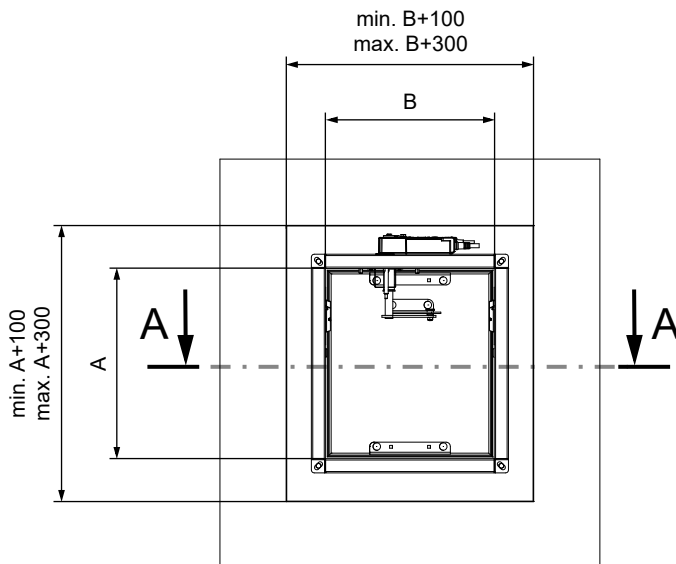
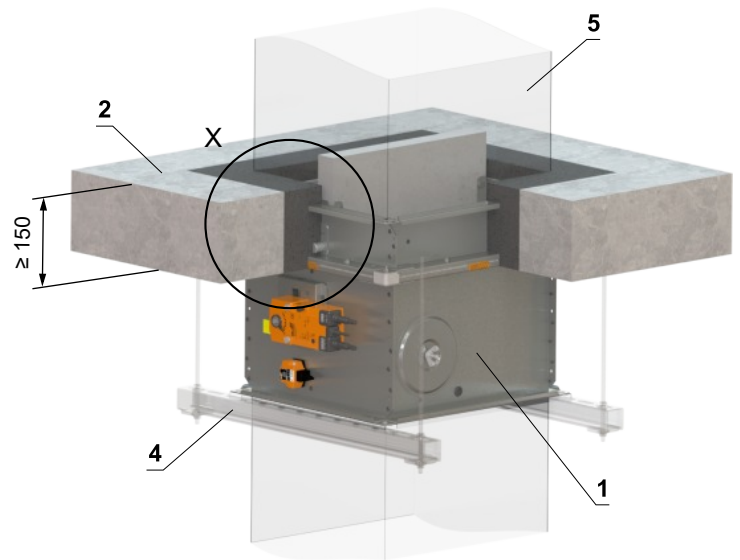
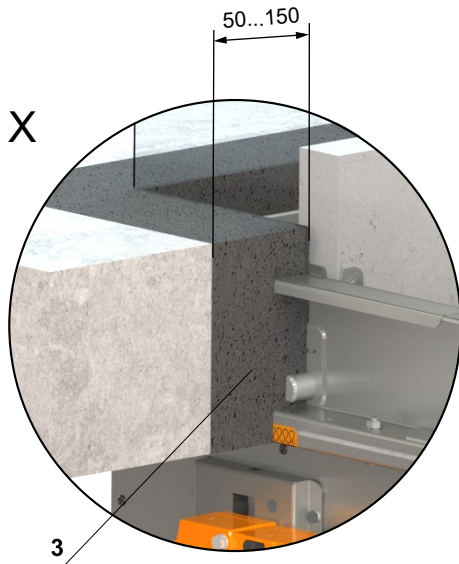

- 1 FDMQ
- 2 Solid ceiling construction
- 3 Mortar or gypsum
- 4 Profile with threaded rod → see pages 74 to 77
- 5 Duct

In solid ceiling construction - 2 dampers in battery - mortar or gypsum

EI 90 (h_o i↔o) S

- For connection of following duct → see page 78
- The gap between the damper and construction is filled with mortar or gypsum
- The damper can be installed from both sides of the construction, i.e. from the top or the bottom side of the ceiling.

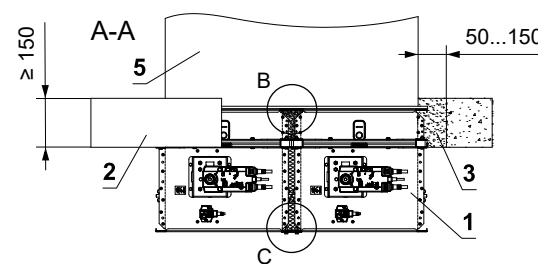
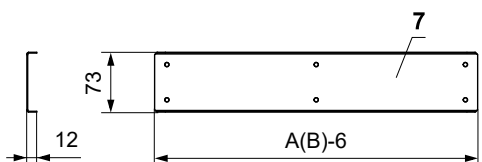
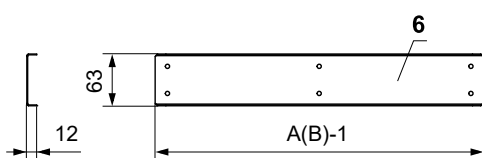
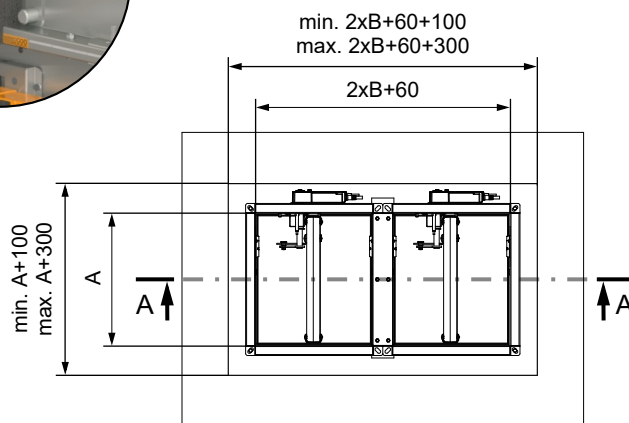
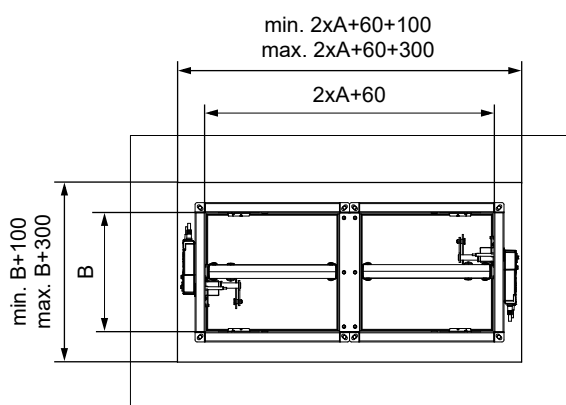
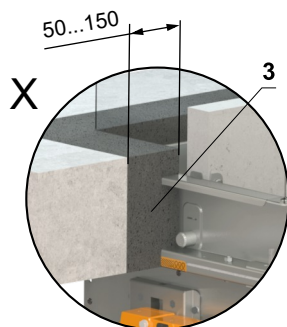
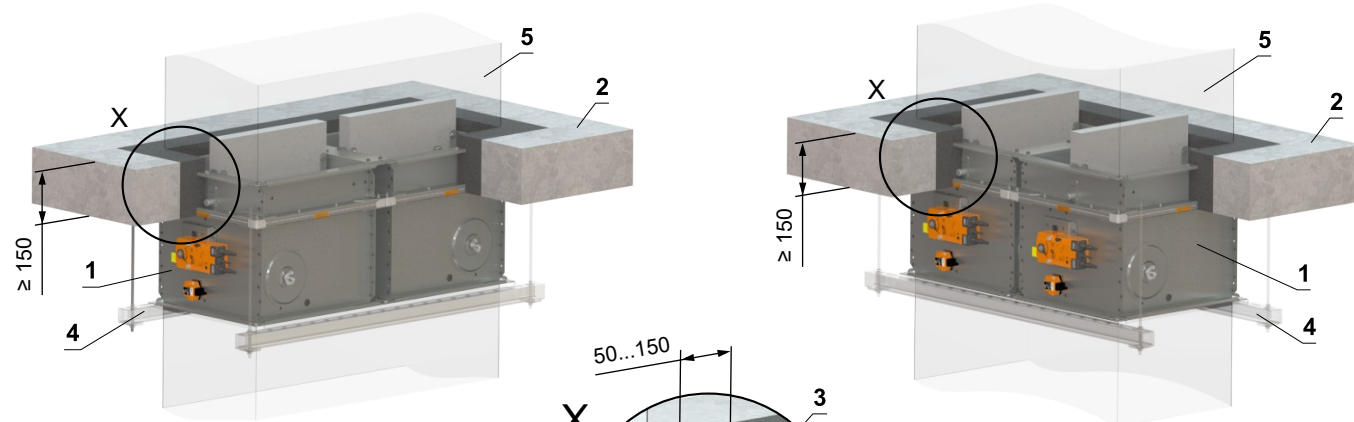

- 1 FDMQ
- 2 Solid ceiling construction
- 3 Mortar or gypsum
- 4 Profile with threaded rod → see pages 74 to 77
- 5 Duct
- 6 U-profile type 3
- 7 U-profile type 1
- 8 Screw TEX 4,8x18 mm (pitch ≤ 200 mm)
- 9 Sealing
- 10 Insulation board made of mineral wool - recommended for easy filling of gap with mortar/gypsum.

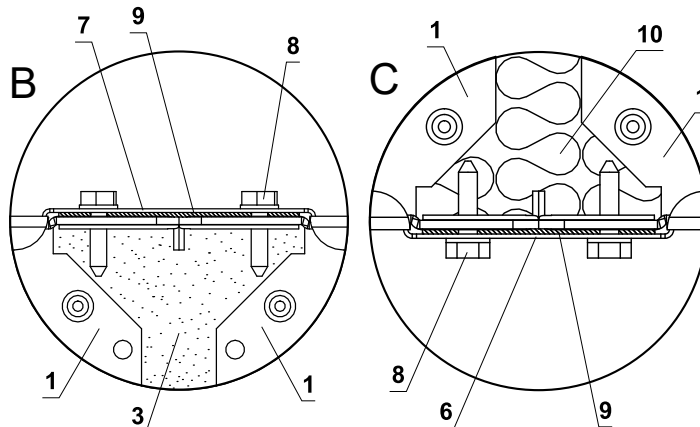

In solid ceiling construction - 4 dampers in battery - mortar or gypsum

EI 90 (h_o i↔o) S

- The damper can be installed from both sides of the construction, i.e. from the top or the bottom side of the ceiling.

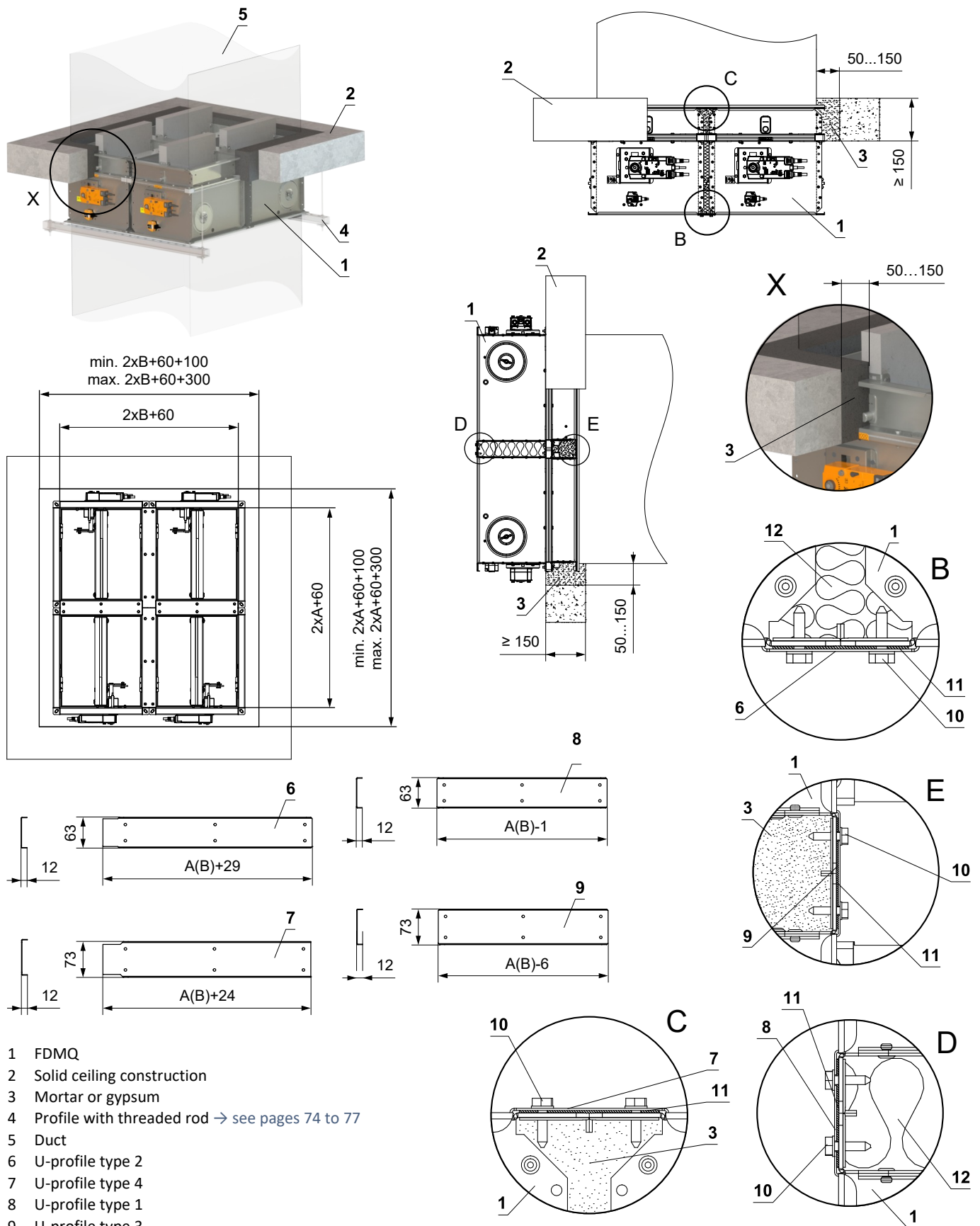

- 1 FDMQ
- 2 Solid ceiling construction
- 3 Mortar or gypsum
- 4 Profile with threaded rod → see pages 74 to 77
- 5 Duct
- 6 U-profile type 2
- 7 U-profile type 4
- 8 U-profile type 1
- 9 U-profile type 3
- 10 Screw TEX 4,8x18 mm (pitch ≤ 200 mm)
- 11 Sealing
- 12 Insulation board made of mineral wool - recommended for easy filling of gap with mortar/gypsum.

- For connection of following duct → see page 78
- The gap between the damper and construction is filled with mortar or gypsum

In solid ceiling construction - Ablative Coated Batt

EI 90 (h_o i↔o) S

- For connection of following duct → see page 78
- The damper can be installed from both sides of the construction, i.e. from the top or the bottom side of the ceiling.

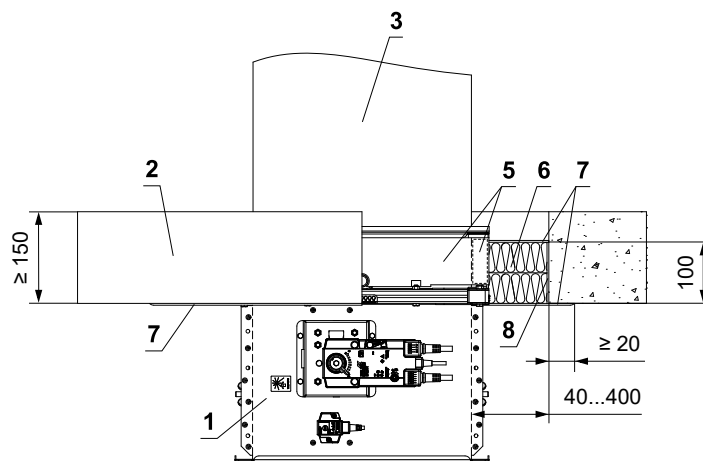
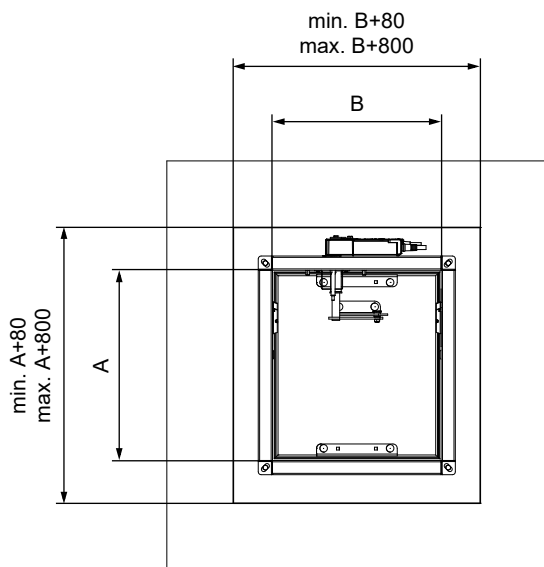
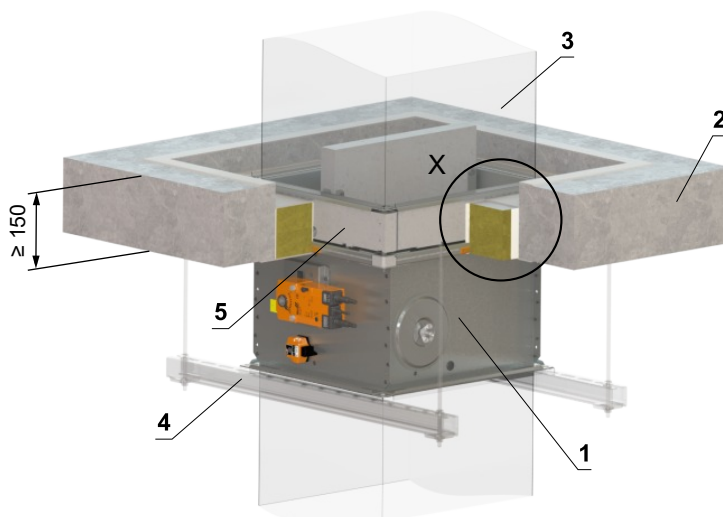
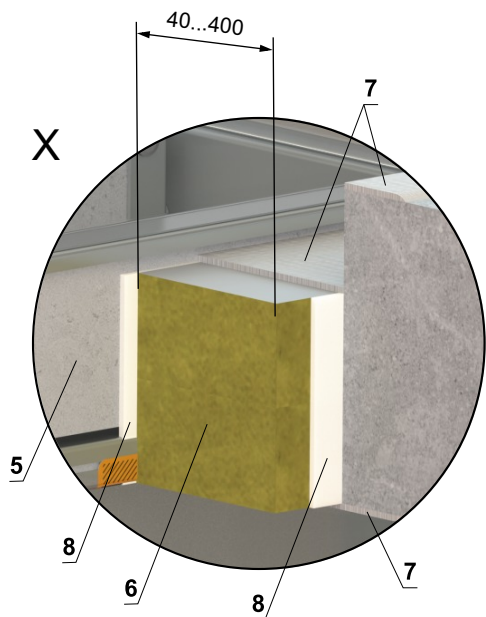

* HILTI system can be replaced by a similar system with the same or higher thickness, density, fire reaction class, tested according to EN 1366-3.

- 1 FDMQ
- 2 Solid ceiling construction
- 3 Duct
- 4 Profile with threaded rod → see pages 74 to 77
- 5 Protective cladding board - min. th. 30 mm, min. density 750 kg/m³ (e.g. PROMATECT-MST) → see page 87
Ablative Coated Batt System HILTI*
- 6 Mineral wool board - min. density 140 kg/m³ (HILTI CFS-CT B 1S 140/50...)
- 7 Fire stop coating - th. 1 mm (HILTI CFS-CT...) - coating is overcoated on the support construction and on the damper casing/duct
- 8 Fire-resistant mastic - (HILTI CFS-S ACR...) fill the gap from both sides of the fire separation construction and around the perimeter of penetration and damper casing

In solid ceiling construction - mineral wool with fire-resistant coating and fire-resistance boards

EI 90 (h_o i↔o) S

- For connection of following duct → see page 78
- The damper can be installed from both sides of the construction, i.e. from the top or the bottom side of the ceiling.

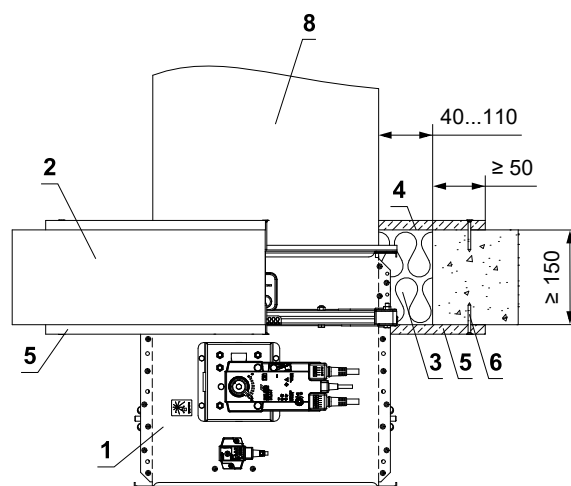
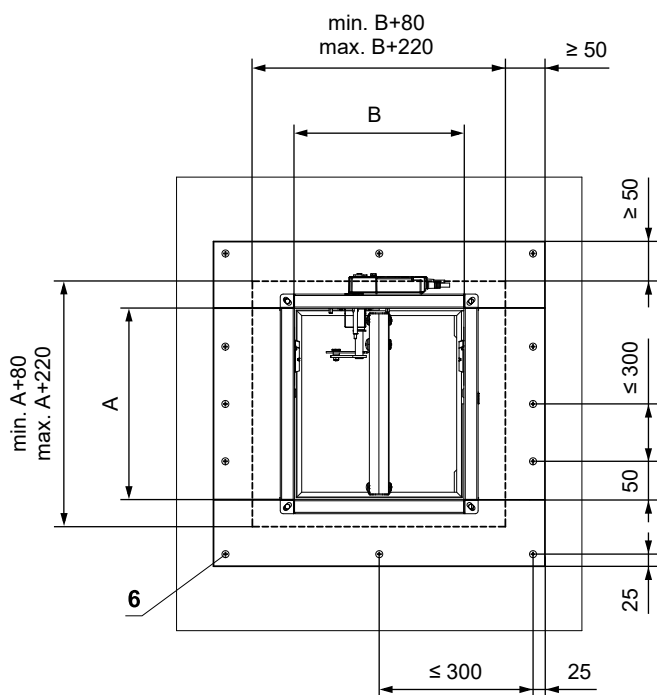
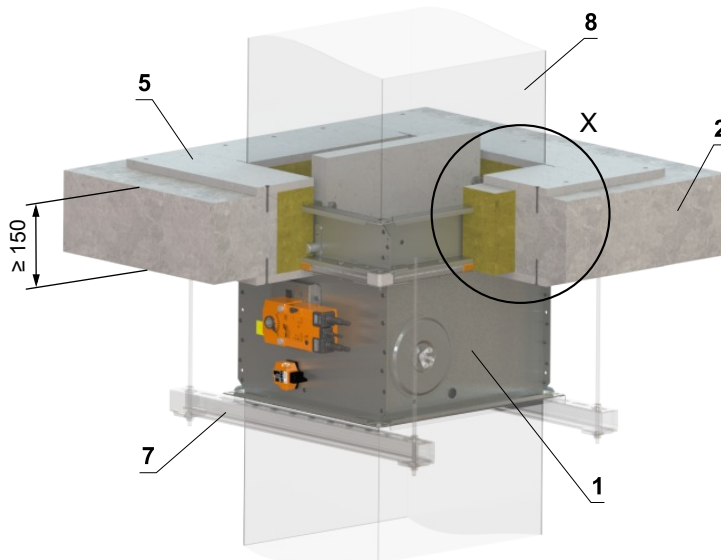
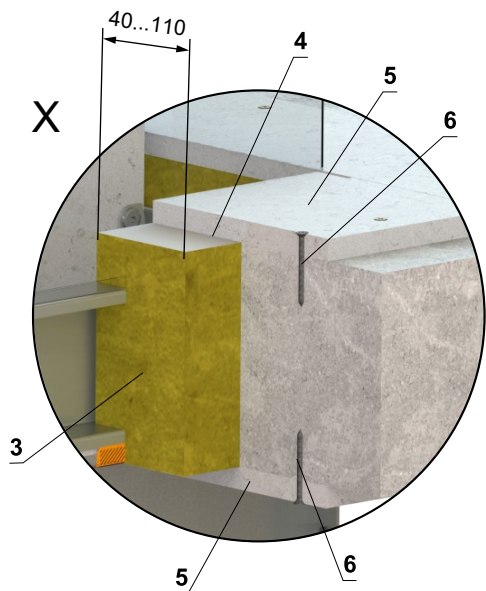

- 1 FDMQ
- 2 Solid ceiling construction
- 3 Mineral wool board - min. density 140 kg/m³ (e.g. PROMAPYR-T150, ROCKWOOL HARDROCK / STEPROCK HD)
- 4 Fire-resistant coating - th. 1 mm (e.g. PROMASTOP-I)
- 5 Fire-resistant board - min. th. 15 mm, min. density 870 kg/m³ (e.g. PROMATECT-H)
- 6 Screw 4x50 mm - screws must be fixed in the wall construction, use steel anchors if necessary
- 7 Profile with threaded rod → see pages 74 to 77
- 8 Duct

Outside solid ceiling construction

Outside solid wall construction - mineral wool ROCKWOOL - mineral wool with fire-resistant coating and fire-resistant board

EI 90 (h_o i↔o) S

- For connection of following duct → see page 78
- Minimum and maximum distance between the ceiling and fire damper is unlimited
- When installing the insulation, follow the ROCKWOOL manufacturer's instructions
- The damper and the duct must be suspended separately
- The duct must be suspended on both sides of damper acc. to national rules
- Duct between fire damper and fire separating construction must be suspended by using threaded rods and mounting profiles, or another mounting system acc. to national standards
- Load of the suspension system depends on weight of the fire damper and duct system → see page 74
- Max. distance between two suspension systems is 1500 mm
- Duct at the point of penetration must be fixed to the fire separation structure
- Following air-conditioning duct must be suspended or supported so that all load transfer from the following duct to the fire damper is absolutely excluded. Adjacent duct must be suspended or supported, as required by the duct suppliers
- If the threaded rod is located inside the duct insulation, distance between threaded rod and duct is max 30 mm
- If the threaded rod is located outside the duct isolation, distance between threaded rod and isolation is max. 40 mm
- If the damper is installed outside the fire separation construction and a damper side A ≥ 800 mm, VRM-Q reinforcement frame must be used → see page 86
- The damper can be installed from both sides of the construction, i.e. from the top or the bottom side of the ceiling.

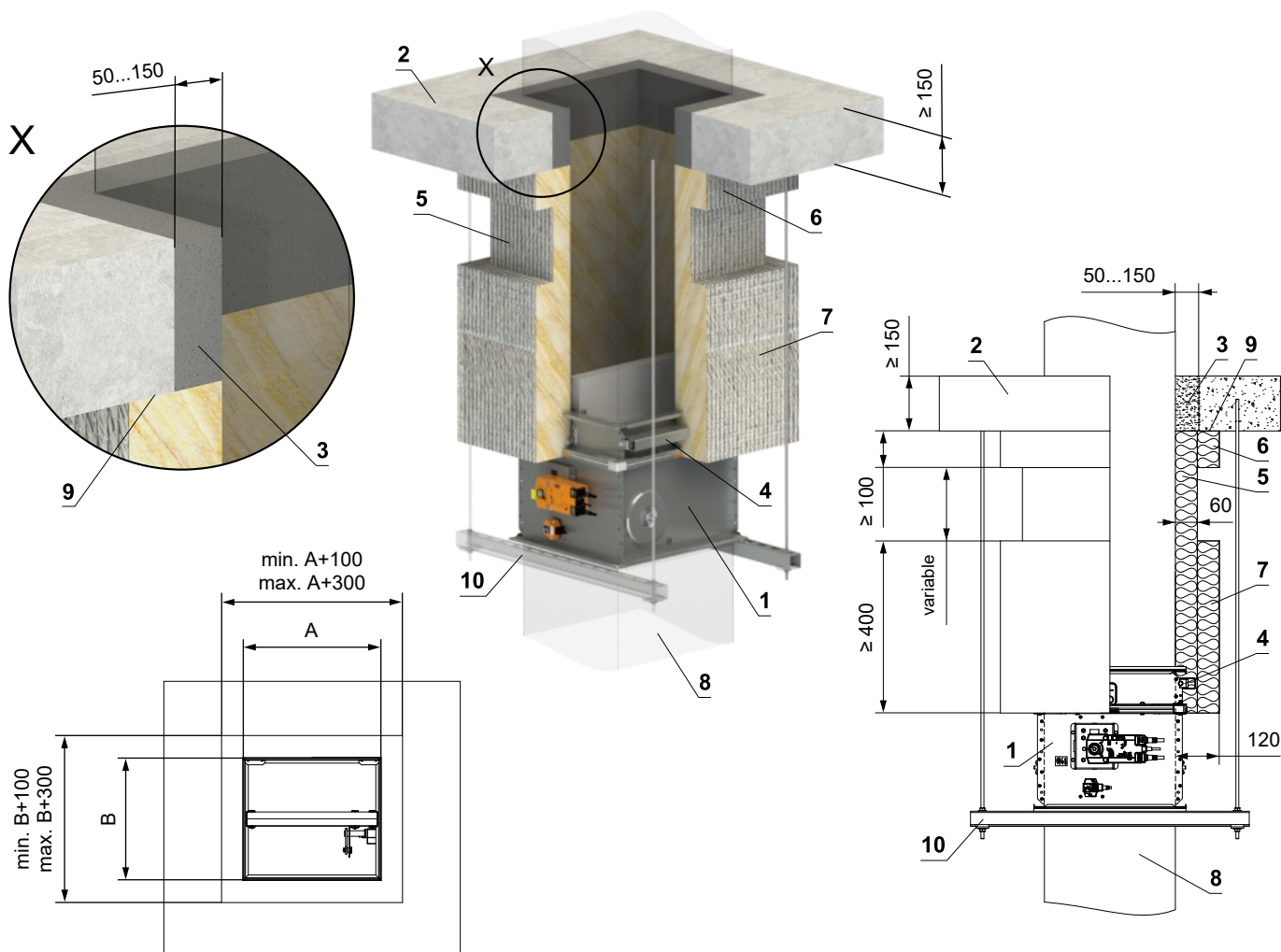

- | | |
|---|---|
| <ol style="list-style-type: none"> 1 FDMQ 2 Solid ceiling construction 3 Mortar or gypsum 4 VRM-Q → see page 86 5 Insulation board made of mineral wool, with a surface treatment of aluminum foil - th. 60 mm, min. density 300 kg/m³ - (System ROCKWOOL Conlit Ductrock 90) 6 Duct penetration insulation collar - th. 60 mm (System ROCKWOOL Conlit Ductrock 90) - glued (pos. 12) and fixed with screws to the wall construction | <ol style="list-style-type: none"> 7 Insulation collar of the damper and duct connection - th. 60 mm (System ROCKWOOL Conlit Ductrock 90) 8 Standard air duct, made of galvanized sheet metal min. thickness 0,8 mm – the duct must be anchored on both sides of the fire-separating structure, e.g. using L-profiles 30 × 30 × 3 mm – according to the ISOVER manufacturer's instructions 9 ROCKWOOL Firepro glue - apply on the insulation and fix it to the fire separation construction 10 Profile with threaded rod → see pages 74 to 77 |
|---|---|

Outside solid ceiling construction - concreting

EI 90 (h_o i↔o) S

- For connection of following duct → see page 78
- The duct must be suspended or supported on both sides of the damper acc. to national rules
- Load of the suspension system depends on weight of the fire damper and duct system → see page 74
- Max. distance between two suspension systems is 1500 mm
- Following air-conditioning duct must be suspended or supported so that all load transfer from the following duct to the fire damper is absolutely excluded. Adjacent duct must be suspended or supported, as required by the duct suppliers

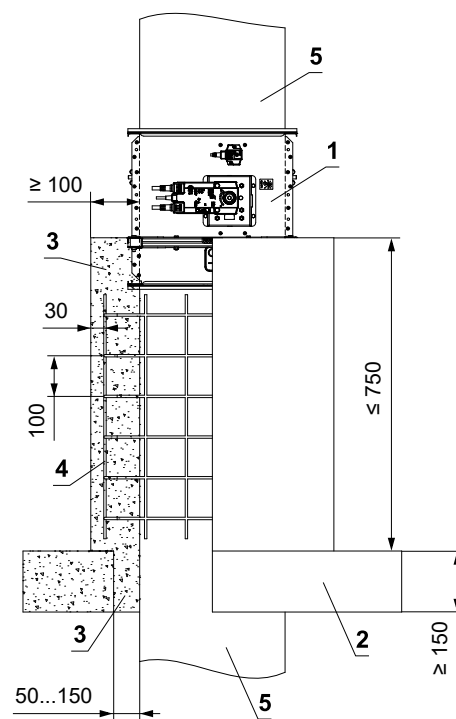
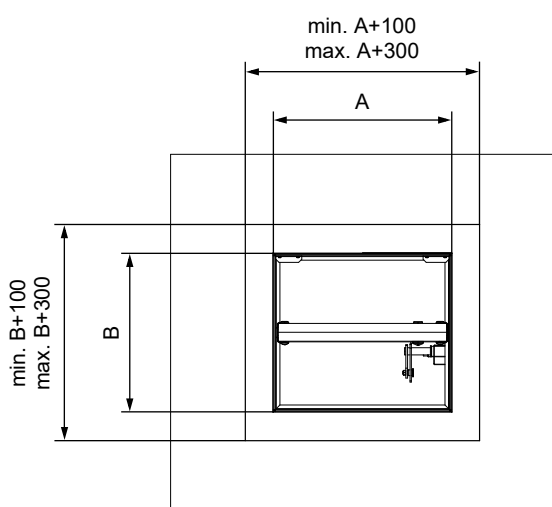
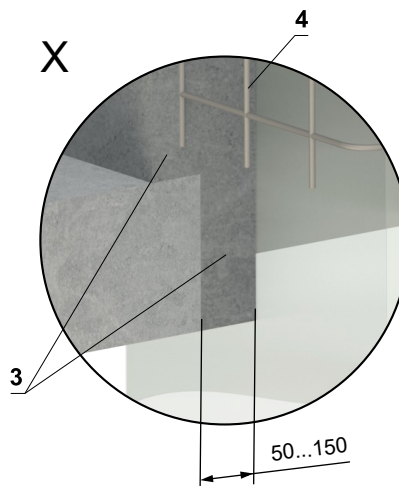
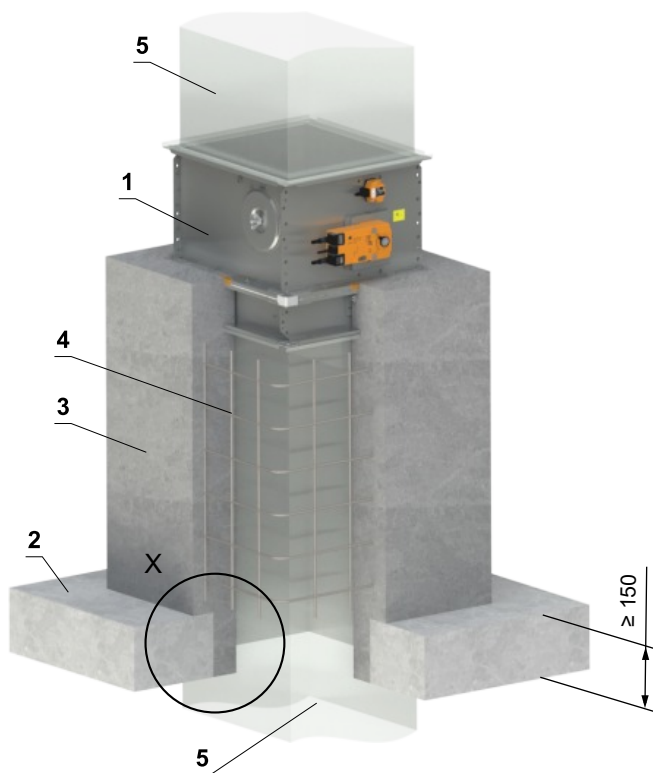

- 1 FDMQ
- 2 Solid ceiling construction
- 3 Concrete B20
- 4 Rebar - steel rod \varnothing 6 mm, mesh hole 100 mm
- 5 Standard air duct, made of galvanized sheet metal min. thickness 0,8 mm

Installation frames

List of installation frames and installation options

Installation frame	Wall thickness (mm)								
	Solid wall construction			Gypsum wall construction			Solid ceiling construction		
	In construction	Outside construction	On construction	In construction	Outside construction	On construction	In construction	Outside construction	On construction
E1	≥ 100	–	–	≥ 100	–	–	≥ 150	–	–
E2	≥ 100	–	–	–	–	–	≥ 150	–	–
E3	–	–	–	≥ 100	–	–	–	–	–
E4	–	–	≥ 100	–	–	≥ 100	–	≥ 150	≥ 150
E5	–	–	–	≥ 100	–	–	–	–	–
E6	–	≥ 100	–	–	–	–	–	≥ 150	–

Installation frame E1

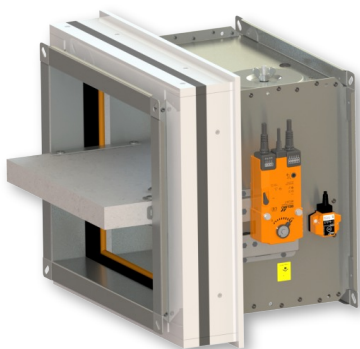

Installation frame E2

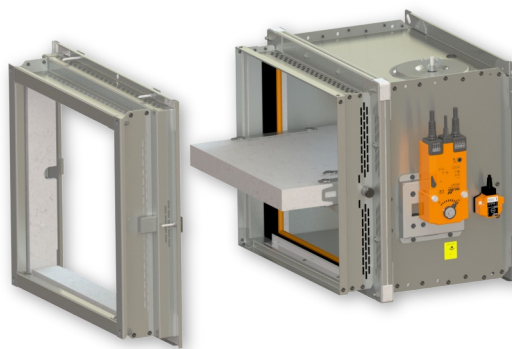

Installation frame E3

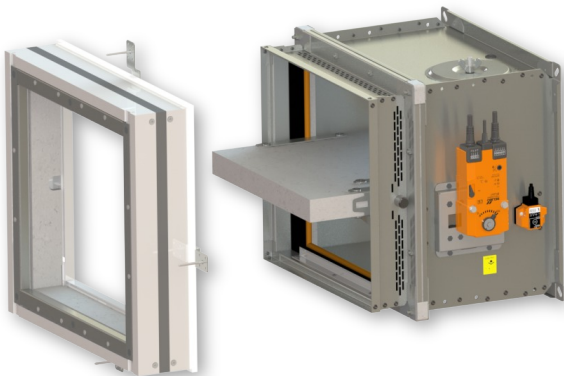

Installation frame E4



Installation frame E5

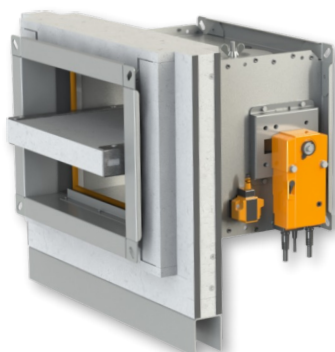

Installation frame E6



- Installation frame can be installed on the damper or delivered separately

Installation frame E1

- Installation frame E1 is designed for installation without additional sealing of the penetration into:
 - Solid wall construction
 - Gypsum wall construction
 - Solid ceiling construction
- Installation frame is equipped with an intumescent sealing on the inside and outside. This sealing fills the gap between the damper casing and frame and between the frame and construction in the event of a fire
- **Solid wall/gypsum wall th. 100 mm or solid ceiling th. 150 mm**
- Material:
 - Installation frame - cement-lime boards
 - Fasteners - galvanized steel

Installation frame E1

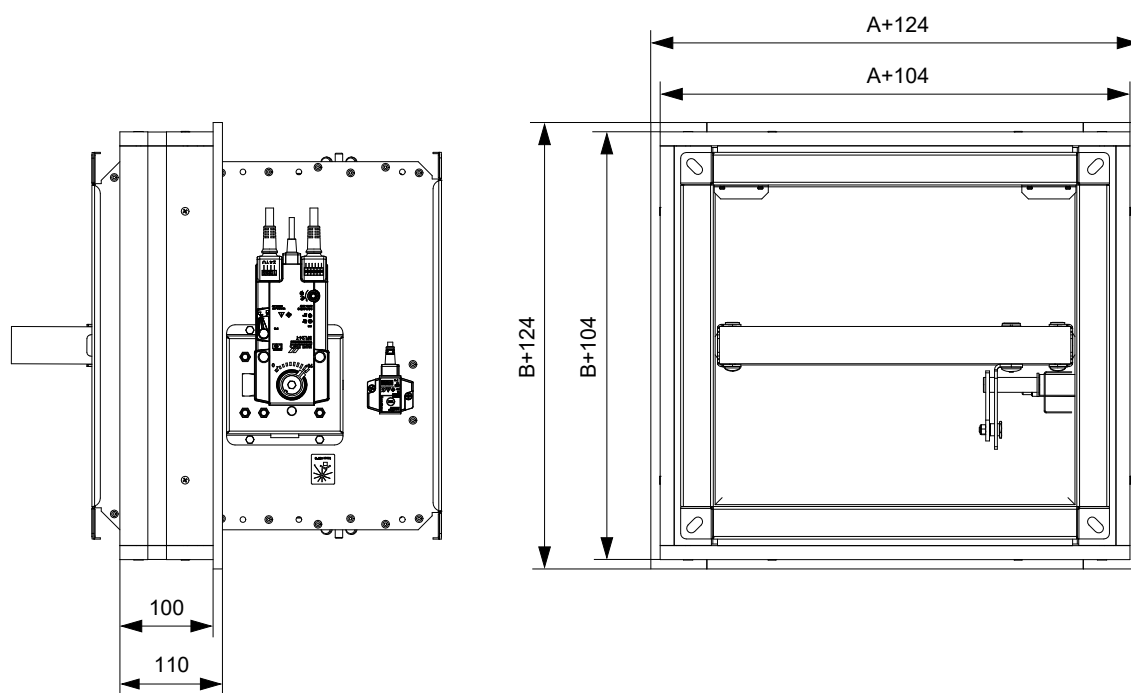
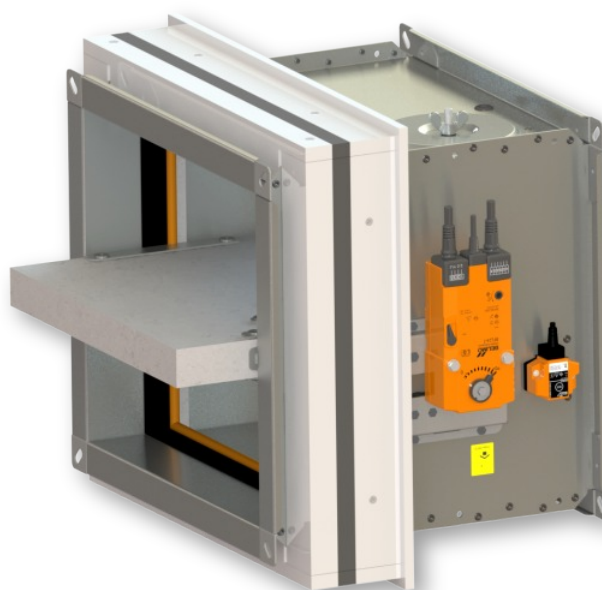

In solid wall construction - installation frame E1

EI 90 (v_e i↔o) S

- For connection of following duct → see page 78
- Installation frame can be installed on the damper or delivered separately

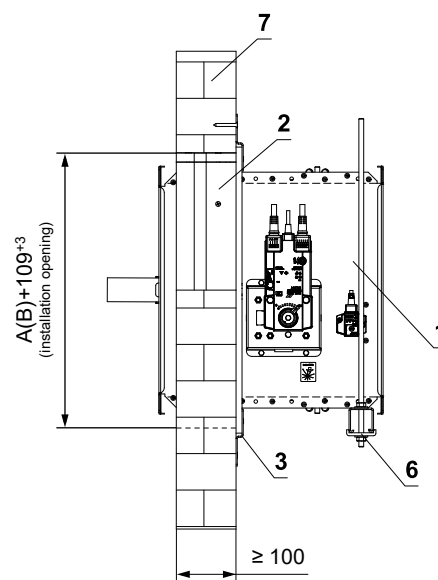
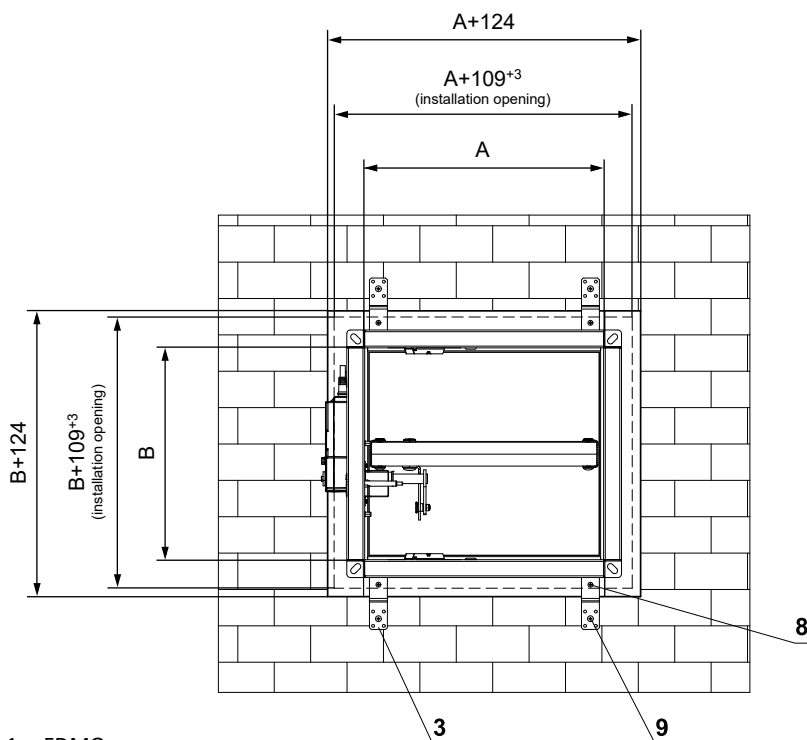
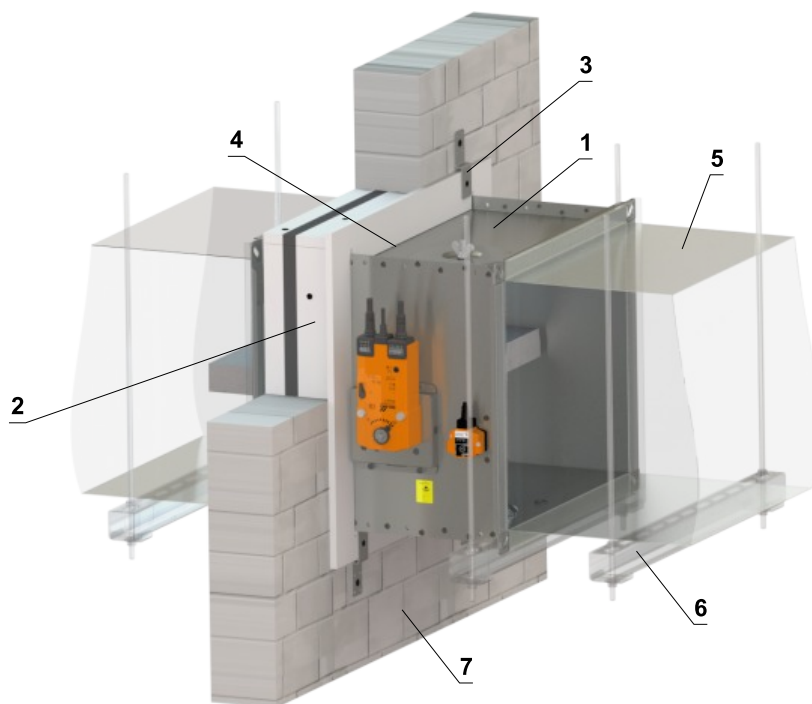

- 1 FDMQ
- 2 Installation frame
- 3 Bracket (fastening material included in frame delivery)
- 4 Fill the gaps with glue PROMAT K84
- 5 Duct
- 6 Profile with threaded rod → see pages 74 to 77
- 7 Solid wall construction
- 8 Screw 4x16 mm to attach bracket to the frame
- 9 Screw 5x60 mm to attach bracket to the construction

Number of brackets X = ZA + ZB Number of screws Y = 2 x X

Side A	Number of brackets ZA	Side B	Number of brackets ZB
A ≤ 500	4	B ≤ 500	0
500 < A ≤ 1000	6	500 < B ≤ 800	4
1000 < A ≤ 1500	8		

Gypsum wall construction - installation frame E1

EI 90 (v_e i↔o) S

- For connection of following duct → see page 78
- Installation frame can be installed on the damper or delivered separately
- The installation opening is lined with a UW/CW profile.

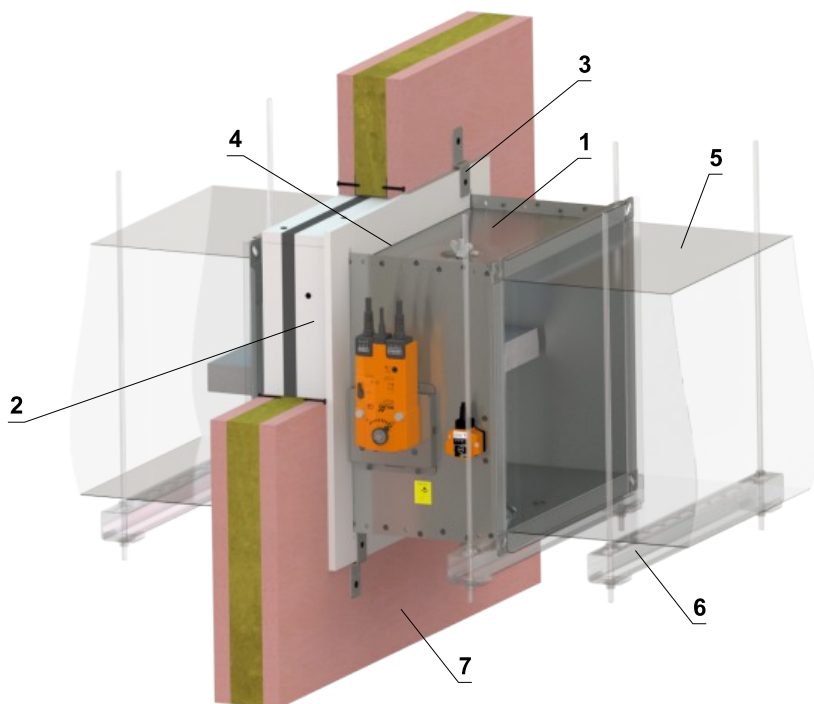

Detail of the wall > 100 mm

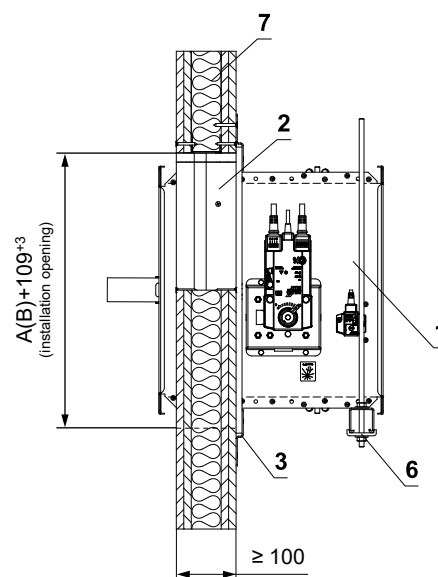
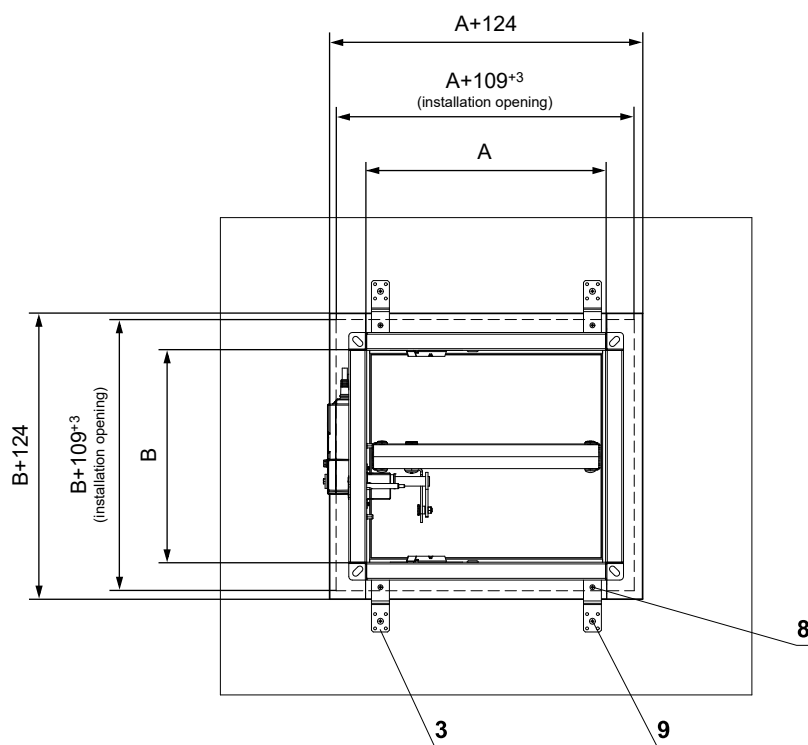
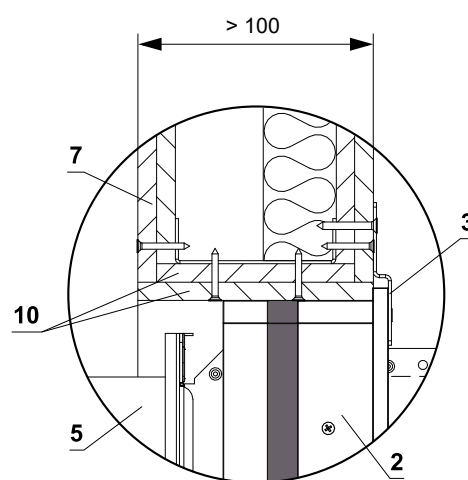

- 1 FDMQ
- 2 Installation frame
- 3 Bracket (fastening material included in frame delivery)
- 4 Fill the gaps with glue PROMAT K84
- 5 Duct
- 6 Profile with threaded rod → see pages 74 to 77
- 7 Gypsum wall construction
- 8 Screw 4x16 mm to attach bracket to the frame
- 9 Screw 5x60 mm to attach bracket to the construction
- 10 Additional boards made from plasterboard

Number of brackets $X = ZA + ZB$ Number of screws $Y = 2 \times X$

Side A	Number of brackets ZA	Side B	Number of brackets ZB
$A \leq 500$	4	$B \leq 500$	0
$500 < A \leq 1000$	6	$500 < B \leq 800$	4
$1000 < A \leq 1500$	8		

Solid ceiling construction - installation frame E1

EI 90 (h_o i↔o) S

- For connection of following duct → see page 78
- Installation frame can be installed on the damper or delivered separately
- The damper can be installed from both sides of the construction, i.e. from the top or the bottom side of the ceiling.

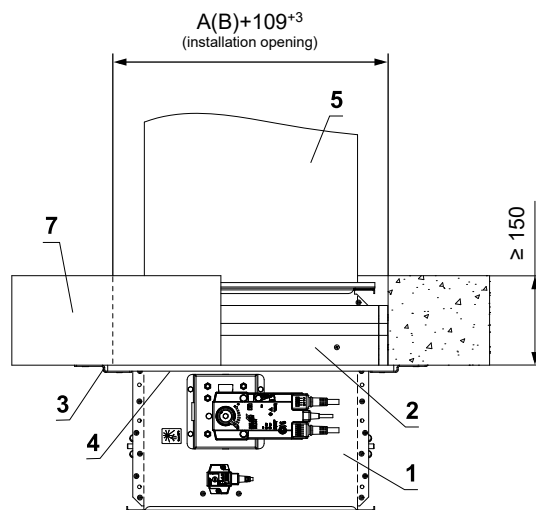
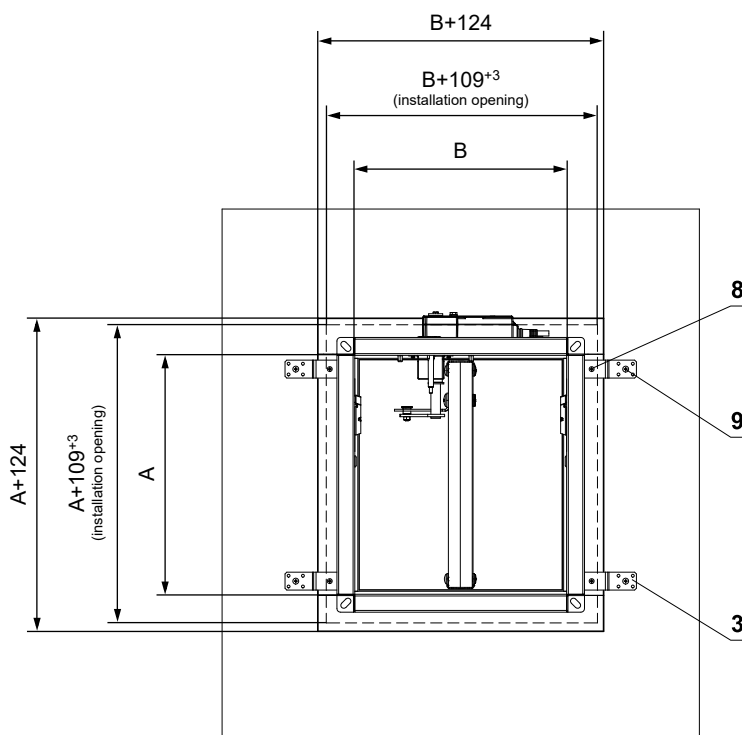
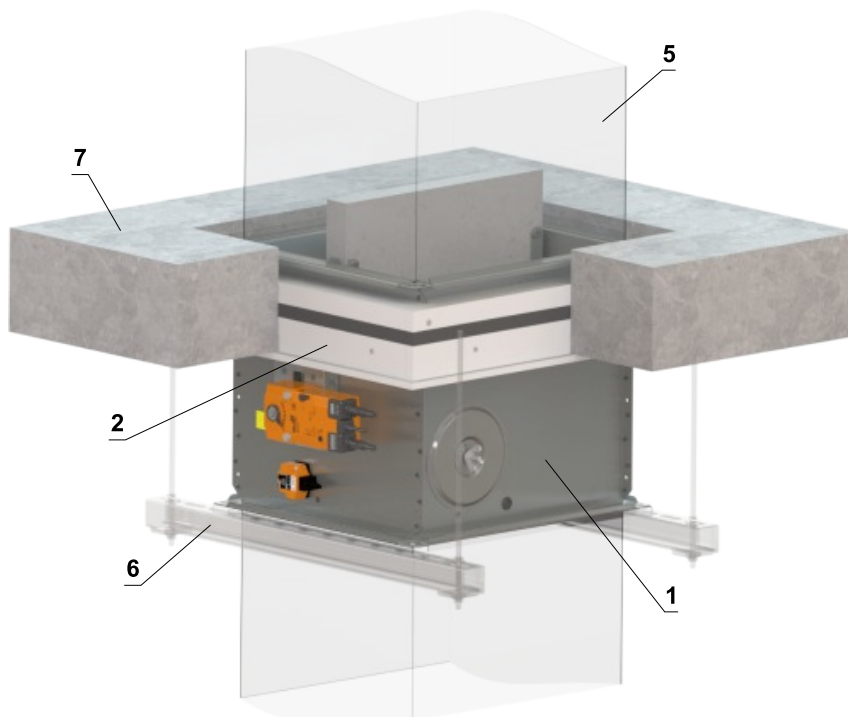

- 1 FDMQ
- 2 Installation frame
- 3 Bracket (fastening material included in frame delivery)
- 4 Fill the gaps with glue PROMAT K84
- 5 Duct
- 6 Profile with threaded rod → see pages 74 to 77
- 7 Solid ceiling construction
- 8 Screw 4x16 mm to attach bracket to the frame
- 9 Screw 5x60 mm to attach bracket to the construction

Number of brackets X = ZA + ZB Number of screws Y = 2 x X

Side A	Number of brackets ZA	Side B	Number of brackets ZB
A ≤ 500	4	B ≤ 500	0
500 < A ≤ 1000	6	500 < B ≤ 800	4
1000 < A ≤ 1500	8		

Installation frame E2

- Installation frame E2 is designed for installation with steel insert and mortar or gypsum into:
 - Solid wall construction
 - Solid ceiling construction
- The damper is equipped with an intumescent sealing on the casing. This sealing fills the gap between the steel insert and the damper in the event of a fire
- **Solid wall th. 100 mm or solid ceiling th. 150 mm**
- Material:
 - Installation frame - galvanized steel
 - Fasteners - galvanized steel

Installation frame E2

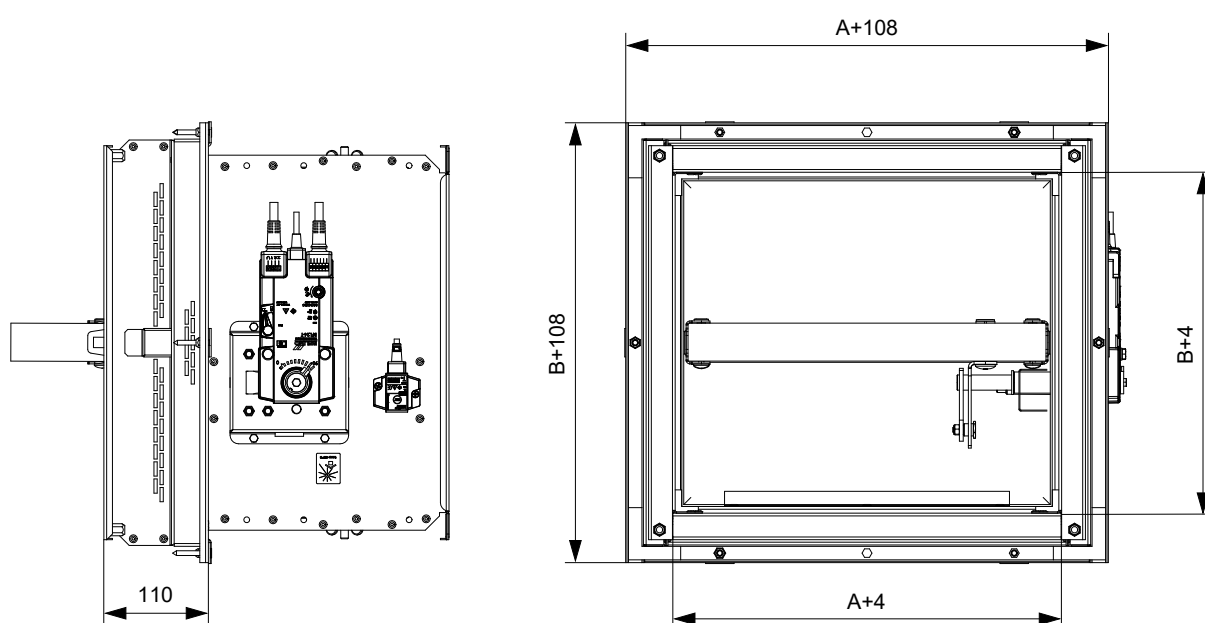
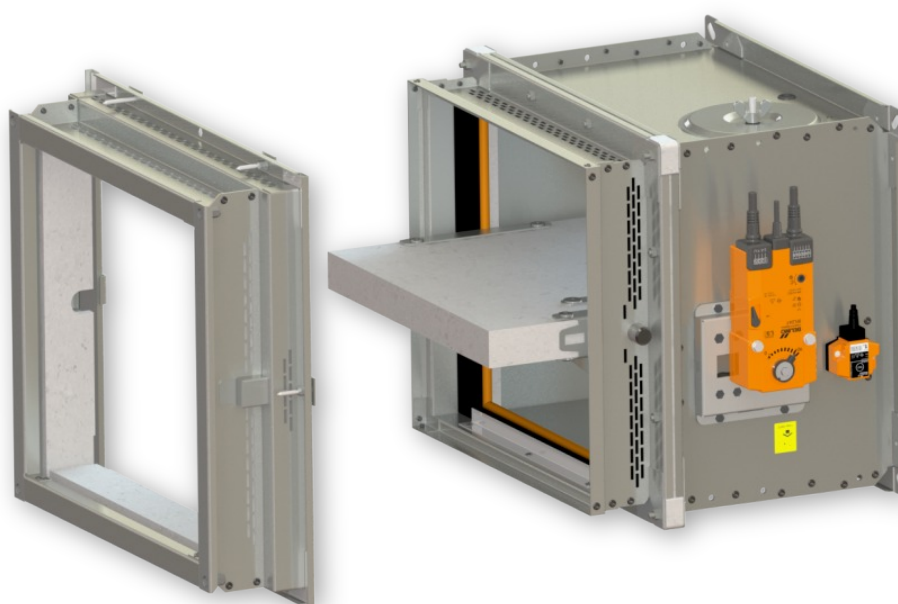

In solid wall construction - installation frame E2

EI 90 (v_e i↔o) S

- For connection of following duct → see page 78
- The installation frame can only be delivered installed on the damper.

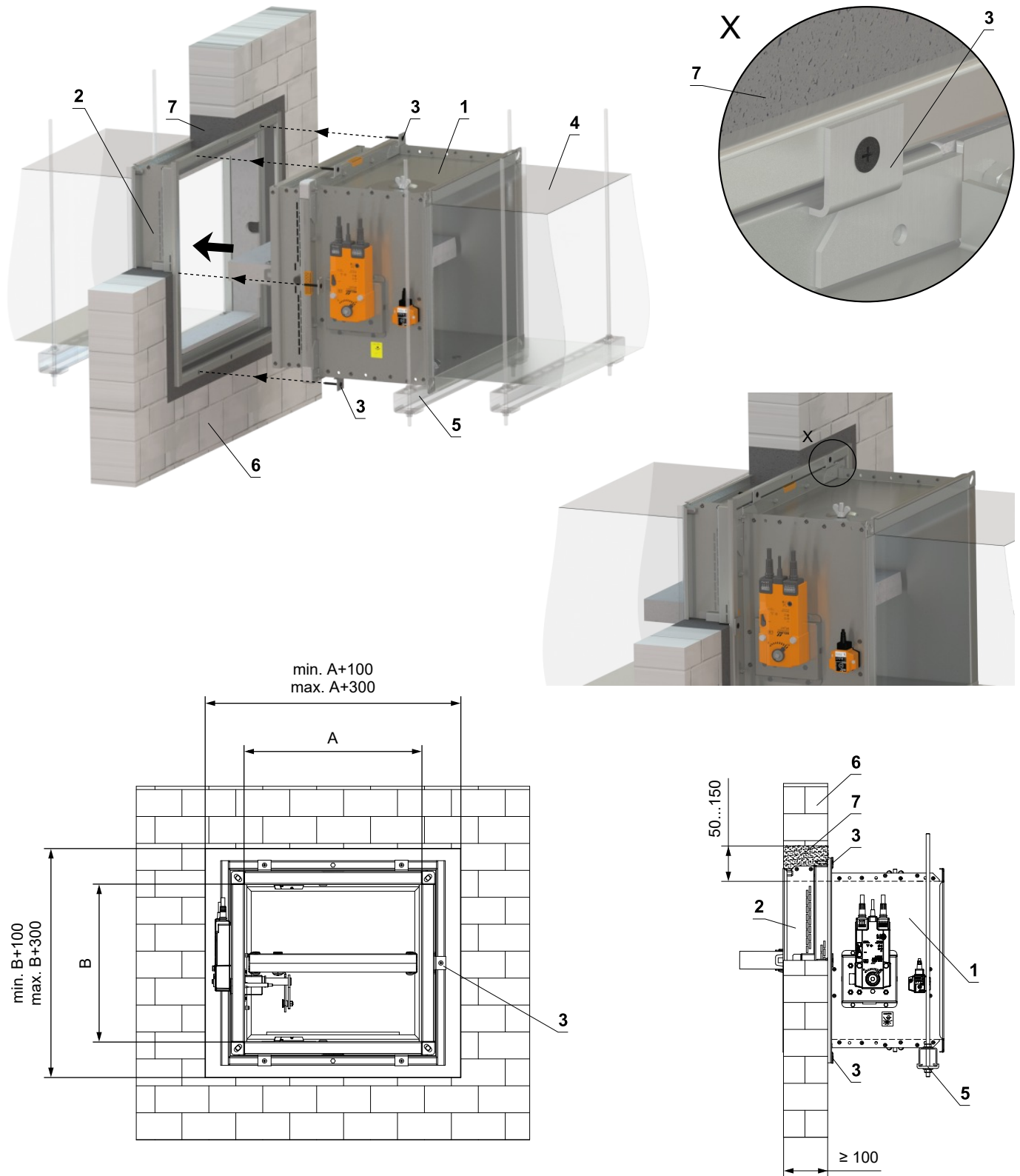

- 1 FDMQ
- 2 Installation frame
- 3 Mounting of the damper to the frame (delivered with frame)
- 4 Duct
- 5 Profile with threaded rod → see pages 74 to 77
- 6 Solid wall construction
- 7 Mortar or gypsum

In solid ceiling construction - installation frame E2

El 90 (h_o i↔o) S

- For connection of following duct → see page 78
- The installation frame can only be delivered installed on the damper.
- The damper can be installed from both sides of the construction, i.e. from the top or the bottom side of the ceiling.

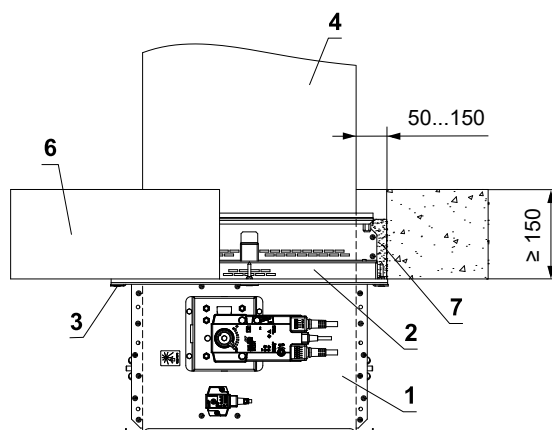
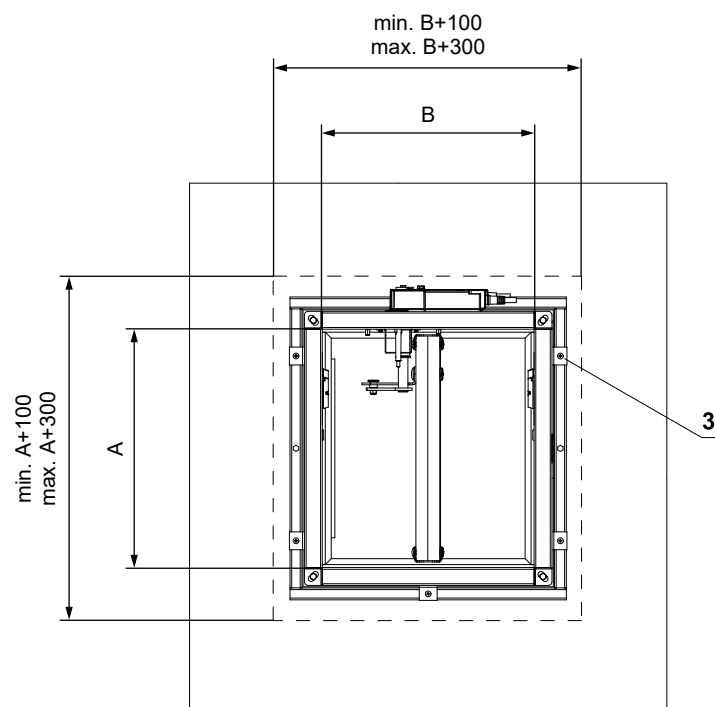
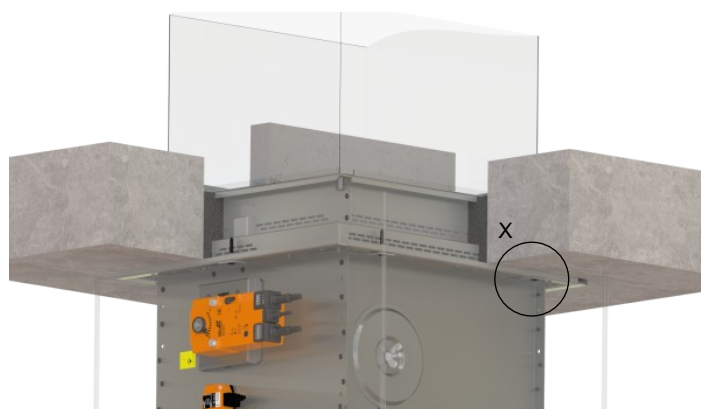
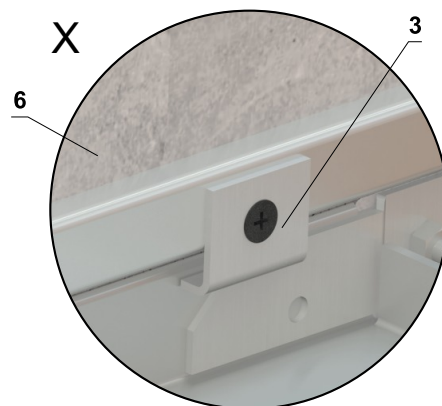
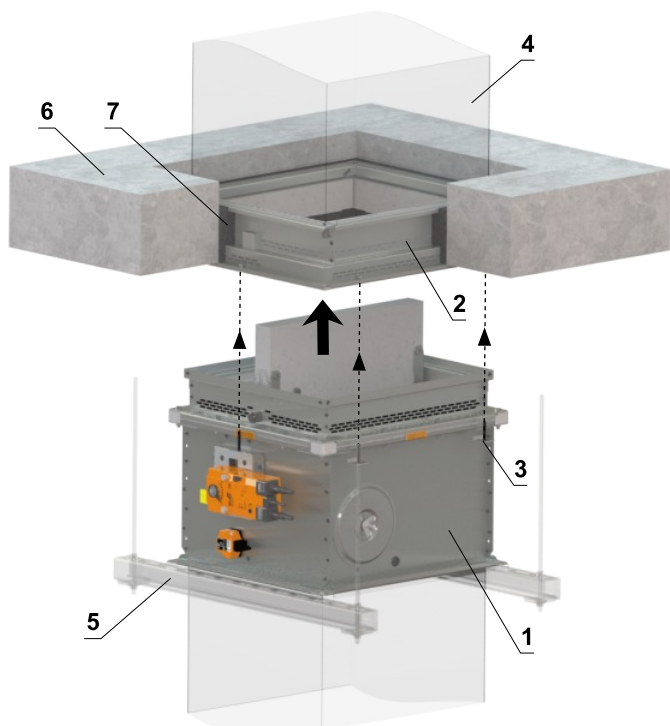

- 1 FDMQ
- 2 Installation frame
- 3 Mounting of the damper to the frame (delivered with frame)
- 4 Duct
- 5 Profile with threaded rod → see pages 74 to 77
- 6 Solid ceiling construction
- 7 Mortar or gypsum

Installation frame E3

- Installation frame E3 is designed for installation into:
 - Gypsum wall construction
- The damper is equipped with an intumescent sealing on the casing. This sealing fills the gap between the damper casing and frame in the event of a fire. The frame is equipped with an intumescent sealing on external side. This sealing fills the gap between the frame and construction in the event of a fire
- **Gypsum wall th. 100 mm**
- Material:
 - Installation frame - cement-lime boards and galvanized steel
 - Fasteners - galvanized steel

Installation frame E3

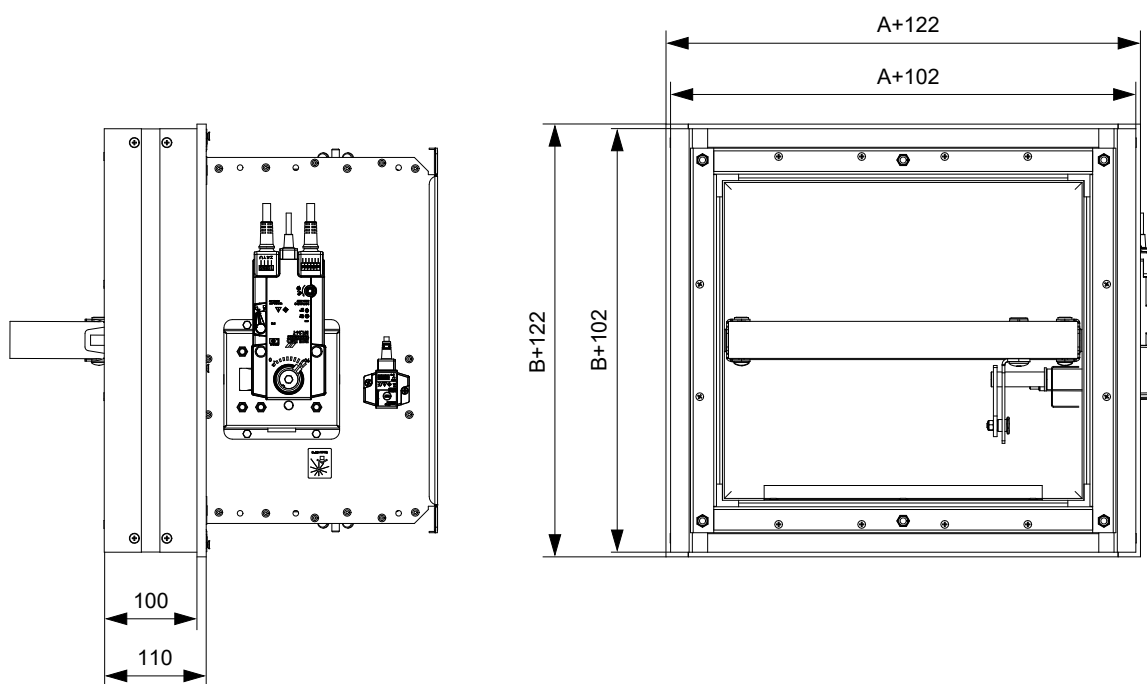
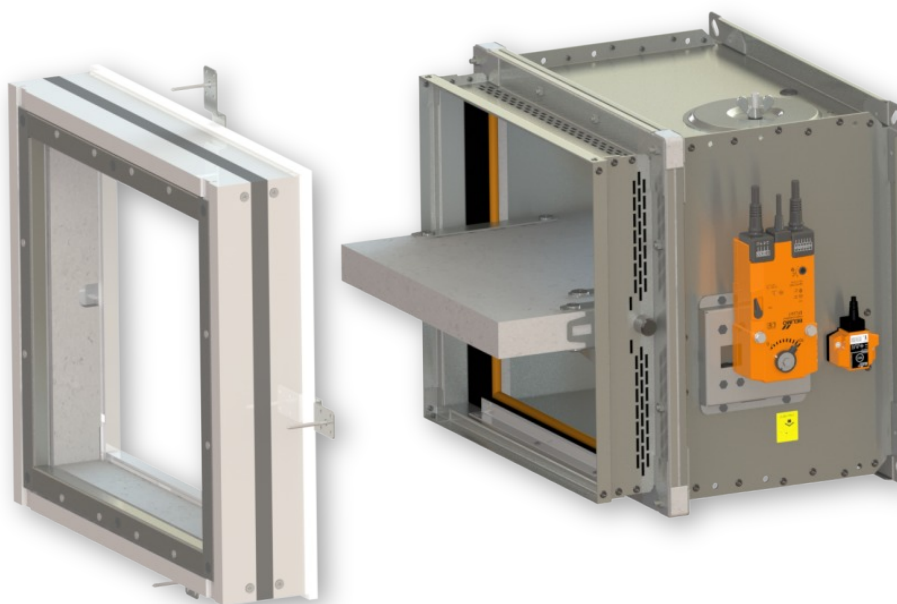

In gypsum wall construction - installation frame E3

EI 90 (v_e i↔o) S

- For connection of following duct → see page 78
- The installation frame can only be delivered installed on the damper.
- The installation opening is lined with a UW/CW profile.

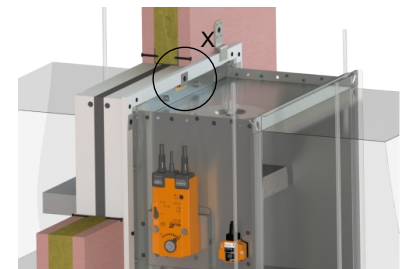
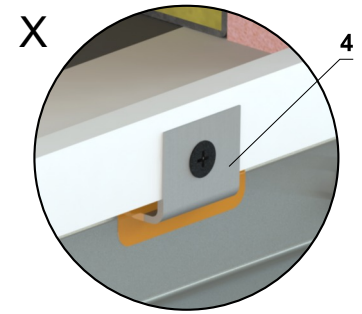
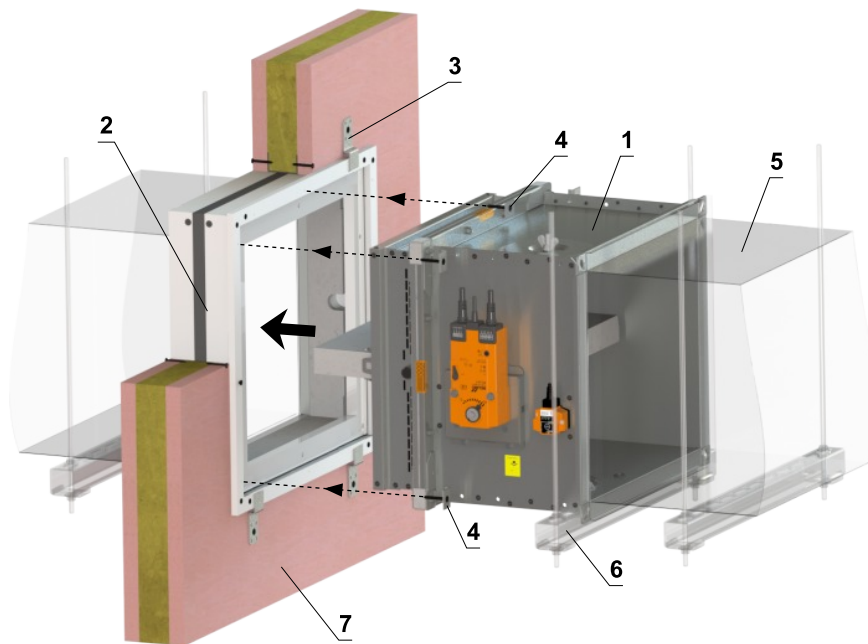

Detail of the wall > 100 mm

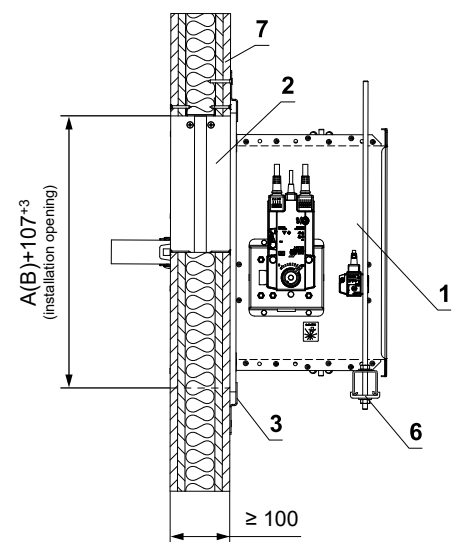
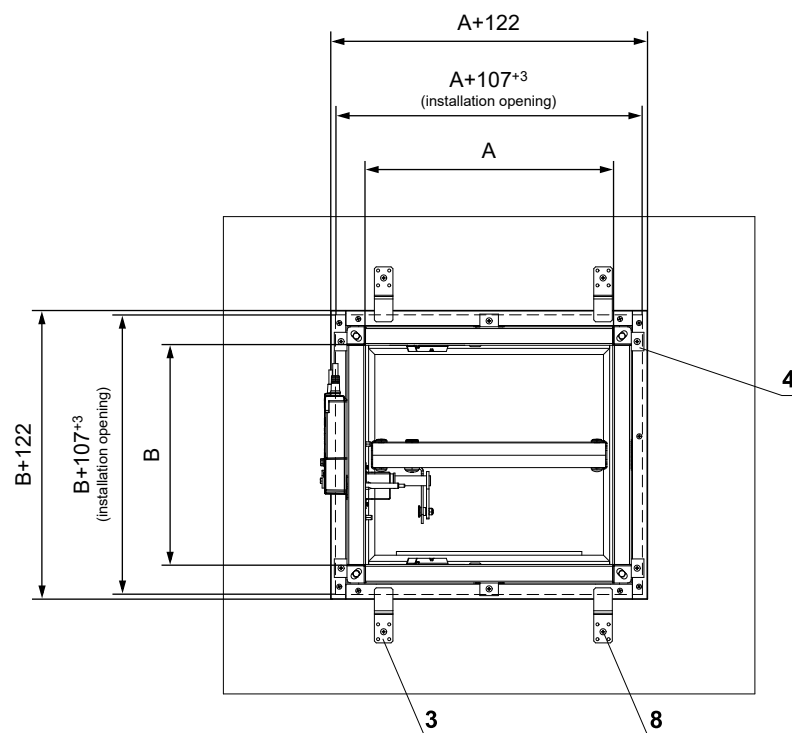
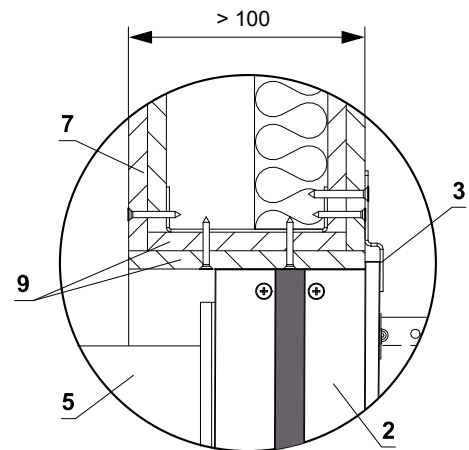

- 1 FDMQ
- 2 Installation frame
- 3 Bracket (fastening material included in frame delivery)
- 4 Mounting of the damper to the frame (delivered with frame)
- 5 Duct
- 6 Profile with threaded rod → see pages 74 to 77
- 7 Gypsum wall construction
- 8 Screw 5x60 mm to attach bracket to the construction
- 9 Additional boards made from plasterboard

Number of brackets X = ZA + ZB Number of screws Y = 2 x X

Side A	Number of brackets ZA	Side B	Number of brackets ZB
A ≤ 500	4	B ≤ 500	0
500 < A ≤ 1000	6	500 < B ≤ 800	4
1000 < A ≤ 1500	8		

Installation frame E4

- Installation frame E4 is designed for installation on:
 - Solid wall construction
 - Solid ceiling construction
 - Outside solid ceiling construction with concreting
- Installation frame is equipped with an intumescent sealing on the inside. This sealing fills the gap between the damper casing and frame in the event of a fire
- Material:
 - Installation frame - cement-lime boards
 - Fasteners - galvanized steel

Installation frame E4

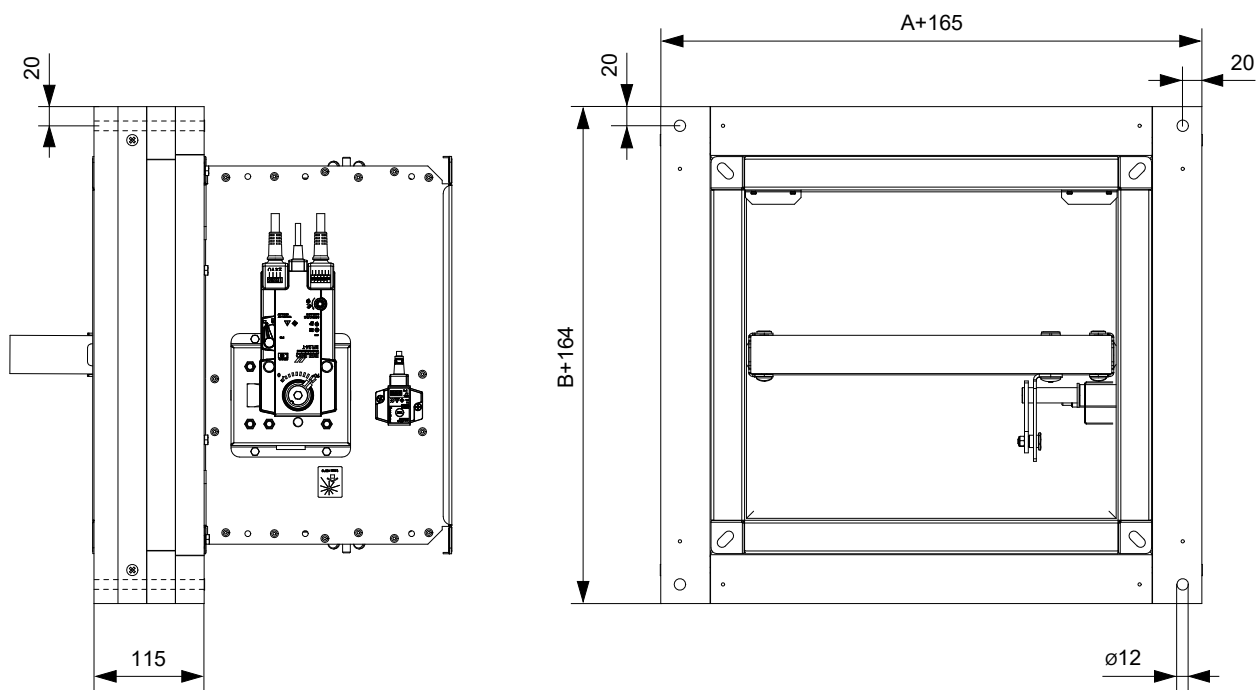

In solid wall construction - installation frame E4

EI 90 (v_e i↔o) S

- For connection of following duct → see page 78
- Installation frame can be installed on the damper or delivered separately

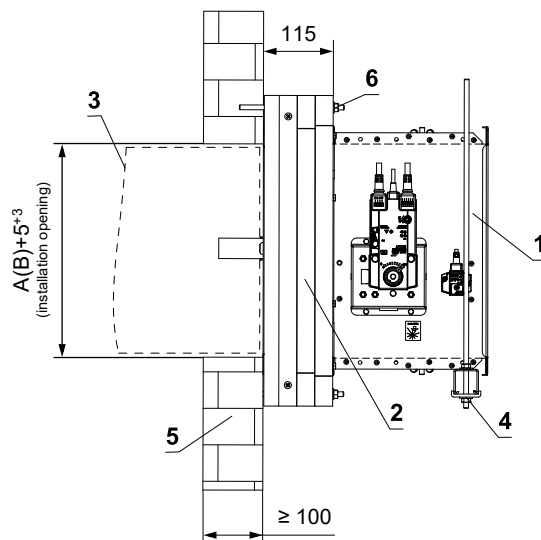
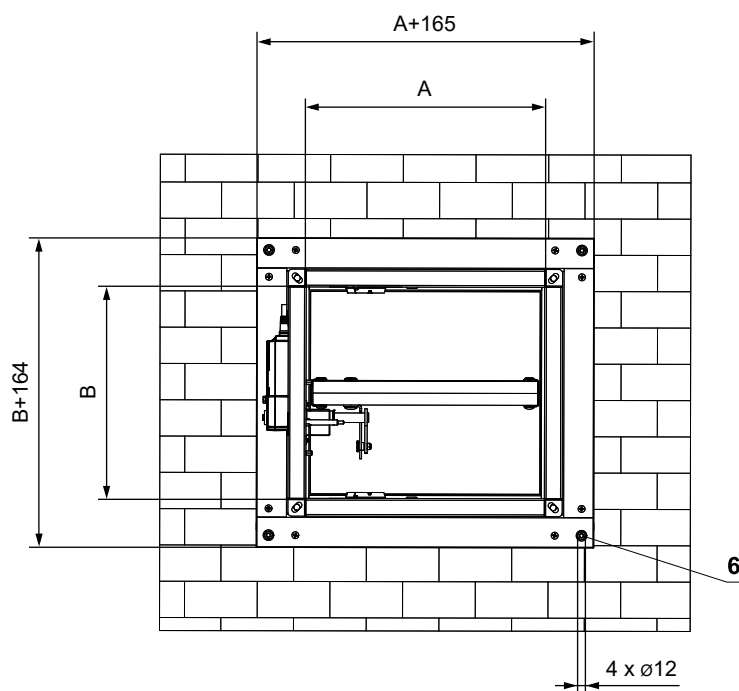
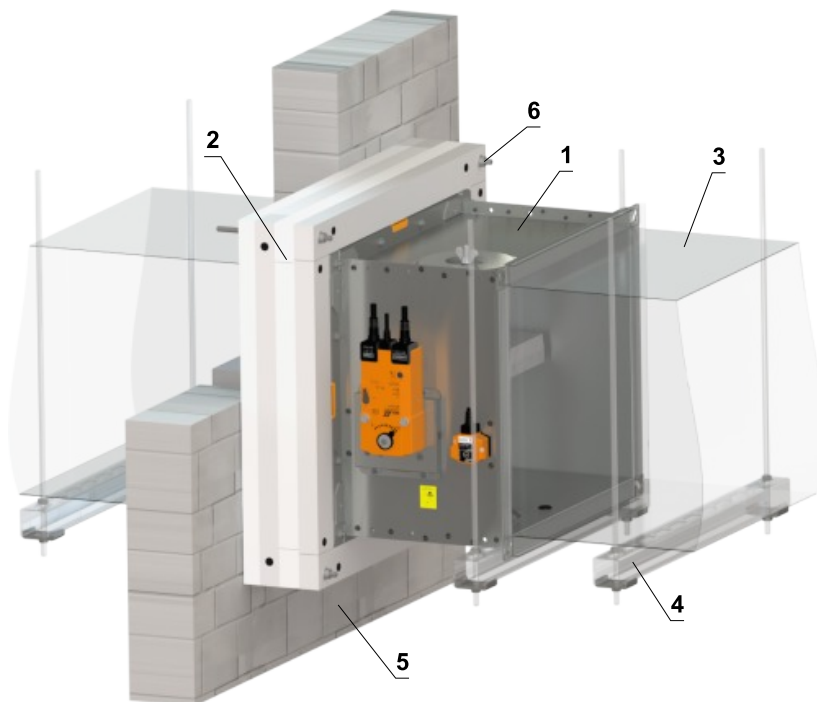

- 1 FDMQ
- 2 Installation frame - apply HILTI CFS-S ACR mastic at the entire area and glue it to the fire separating construction
- 3 Duct
- 4 Profile with threaded rod → see pages 74 to 77
- 5 Solid wall construction
- 6 Holes for fixing the frame with threaded rods or steel anchors (material for fixing the frame is not included)

In solid ceiling construction - installation frame E4

EI 90 (h_o i↔o) S

- For connection of following duct → see page 78
- Installation frame can be installed on the damper or delivered separately
- The damper can be installed from both sides of the construction, i.e. from the top or the bottom side of the ceiling.

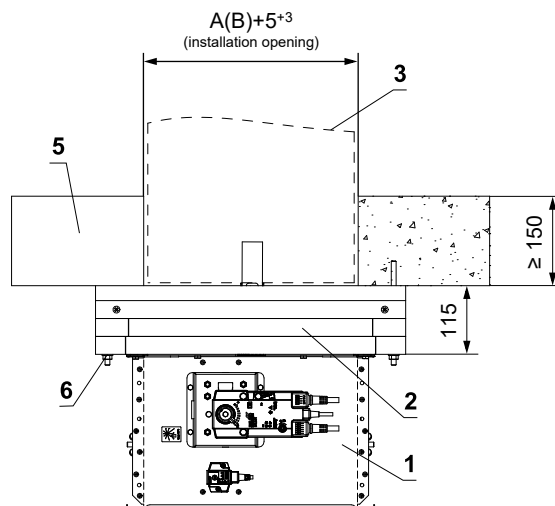
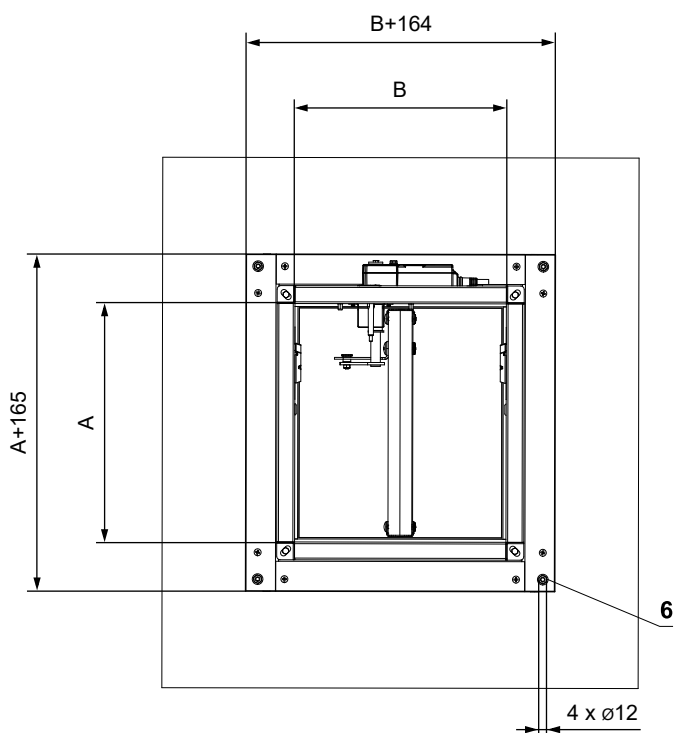
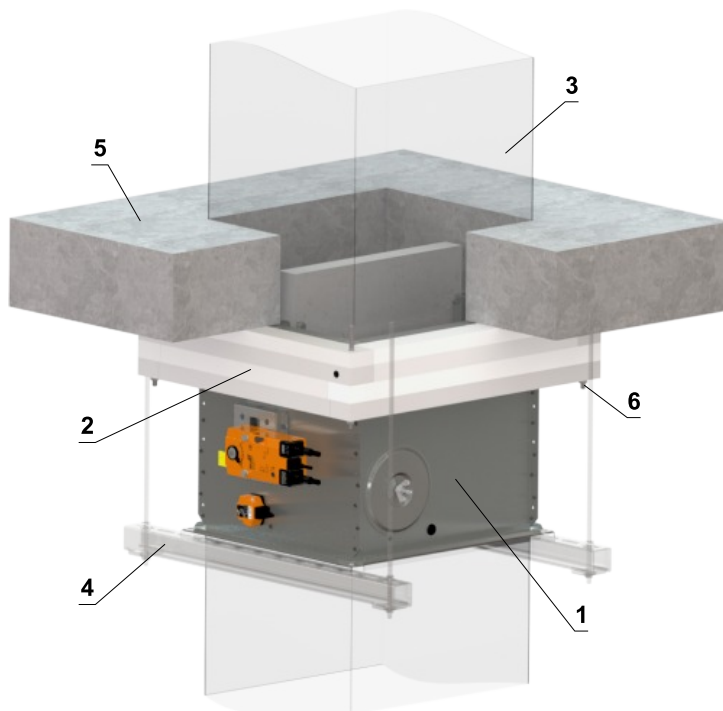

- 1 FDMQ
- 2 Installation frame - apply HILTI CFS-S ACR mastic at the entire area and glue it to the fire separating construction
- 3 Duct
- 4 Profile with threaded rod → see pages 74 to 77
- 5 Solid ceiling construction
- 6 Holes for fixing the frame with threaded rods or steel anchors (material for fixing the frame is not included)

Outside solid ceiling construction - concreting - installation frame E4

EI 90 (h_o i↔o) S

- For connection of following duct → see page 78
- The duct must be suspended or supported on both sides of the damper acc. to national rules
- Load of the suspension system depends on weight of the fire damper and duct system → see page 74
- Max. distance between two suspension systems is 1500 mm
- Following air-conditioning duct must be suspended or supported so that all load transfer from the following duct to the fire damper is absolutely excluded. Adjacent duct must be suspended or supported, as required by the duct suppliers
- Installation frame can be installed on the damper or delivered separately

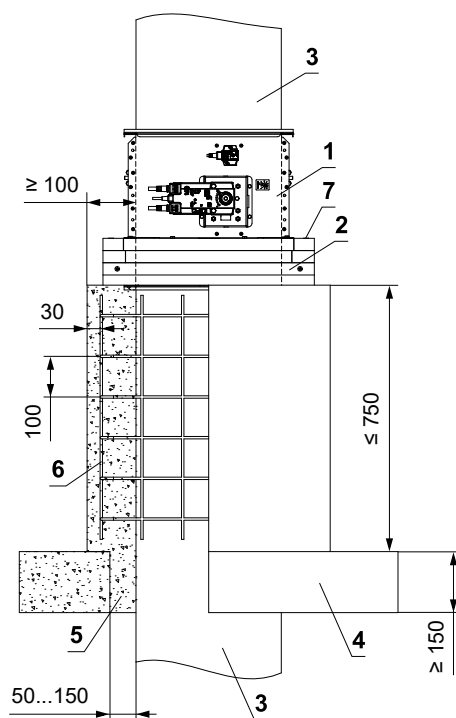
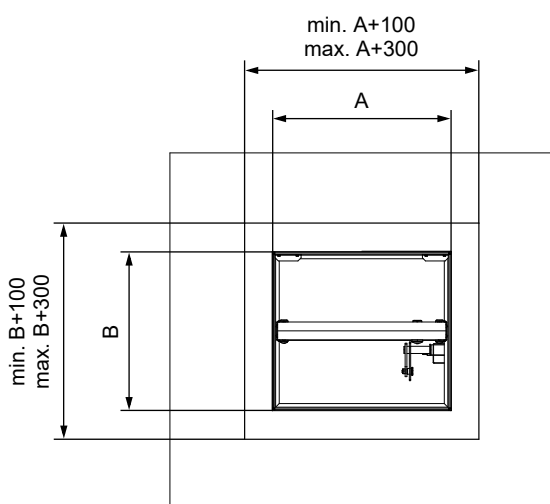
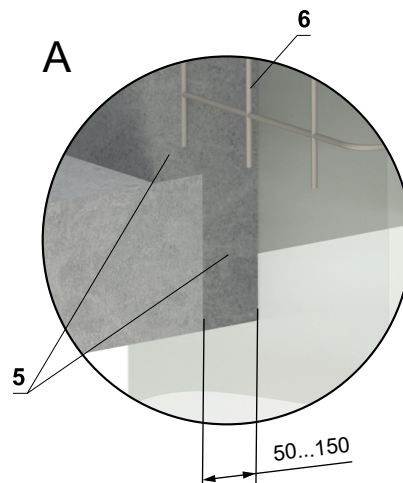
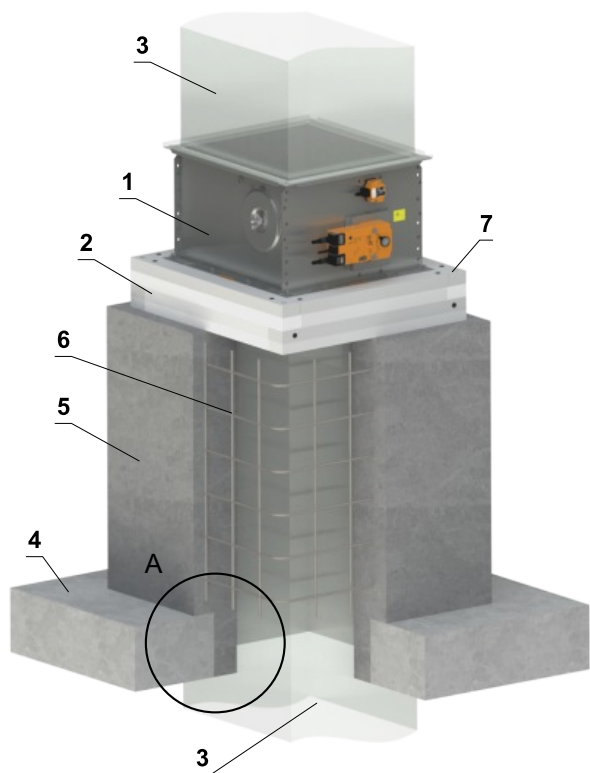

- 1 FDMQ
- 2 Installation frame - apply HILTI CFS-S ACR mastic at the entire area and glue it to the fire separating construction
- 3 Standard air duct, made of galvanized sheet metal min. thickness 0,8 mm
- 4 Solid ceiling construction
- 5 Concrete B20
- 6 Rebar - steel rod \varnothing 6 mm, mesh hole 100 mm
- 7 Holes for fixing the frame with threaded rods or steel anchors (frame fixing material not included)

Installation frame E5

- Installation frame E5 is designed for installation without additional sealing of the penetration for:
 - Installation in gypsum walls under flexible ceilings with a maximum movement of 40 mm
 - Wall thicknesses 100 or ≥ 115 mm
- Installation frame is equipped with an intumescent sealing on the inside and outside. This sealing fills the gap between the damper casing and frame and between the frame and construction in the event of a fire
- Position of the damper can be directly on the ceiling or at a distance of max. 80 mm from the ceiling
- Material:
 - Installation frame - cement-lime boards and galvanized steel
 - Fasteners - galvanized steel

Installation frame E5

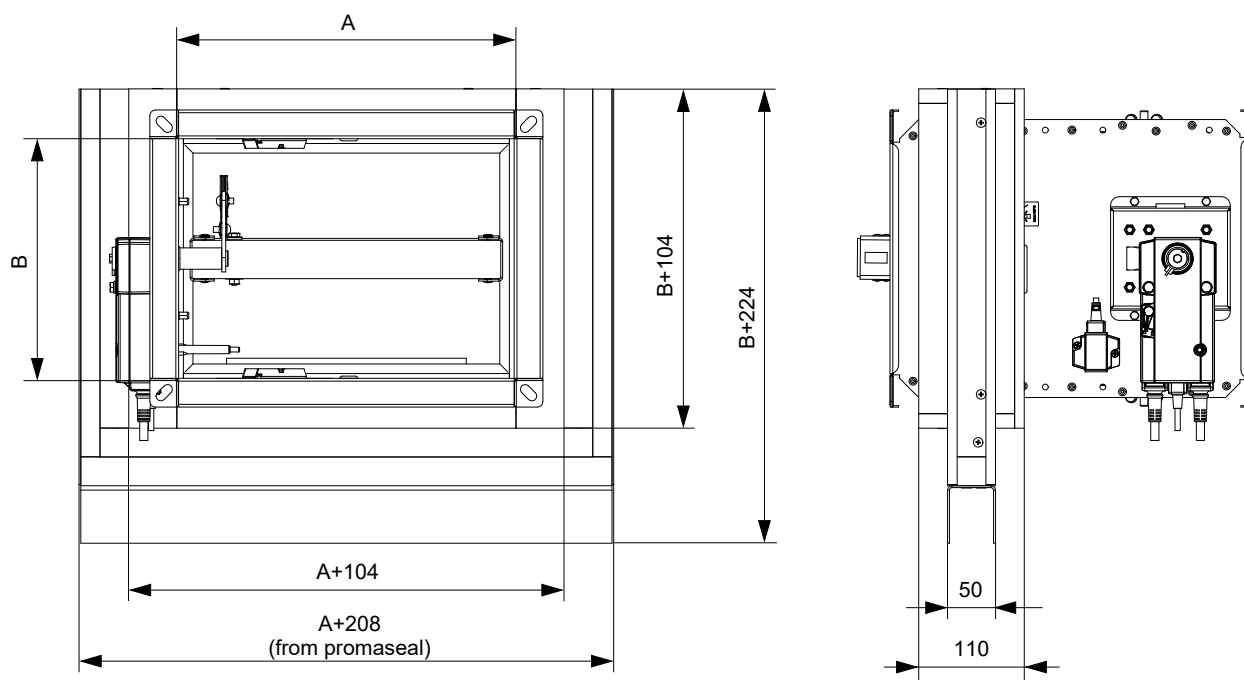
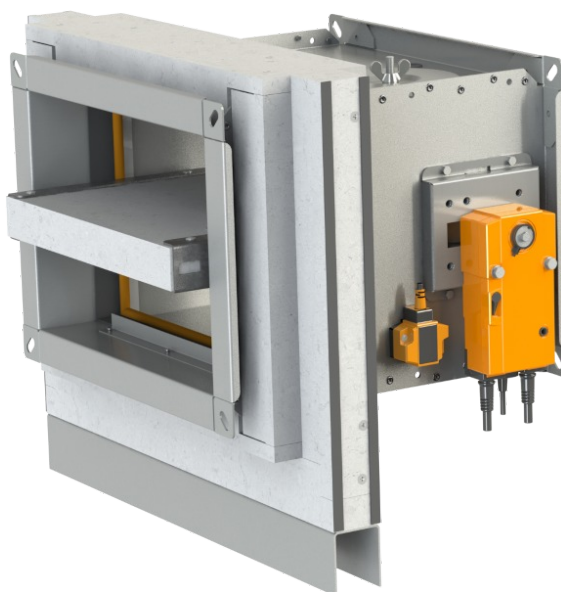

In gypsum wall construction - flexible ceiling - installation frame E5

Installation directly on the ceiling

EI 90 (v_e i↔o) S

- Detailed instructions for installation E5 frame → see manual
- For connection of following duct → see page 78
- Installation frame can be installed on the damper or delivered separately
- Gypsum construction must be made in accordance with the specifications of the wall system manufacturer

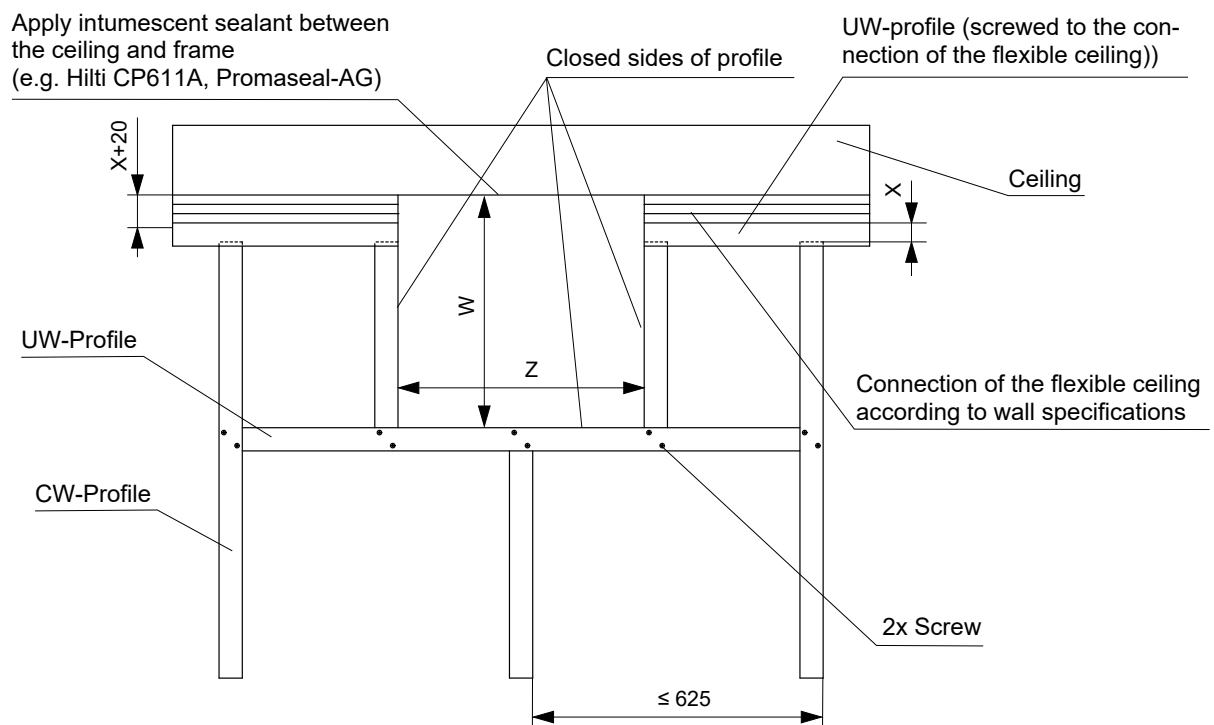
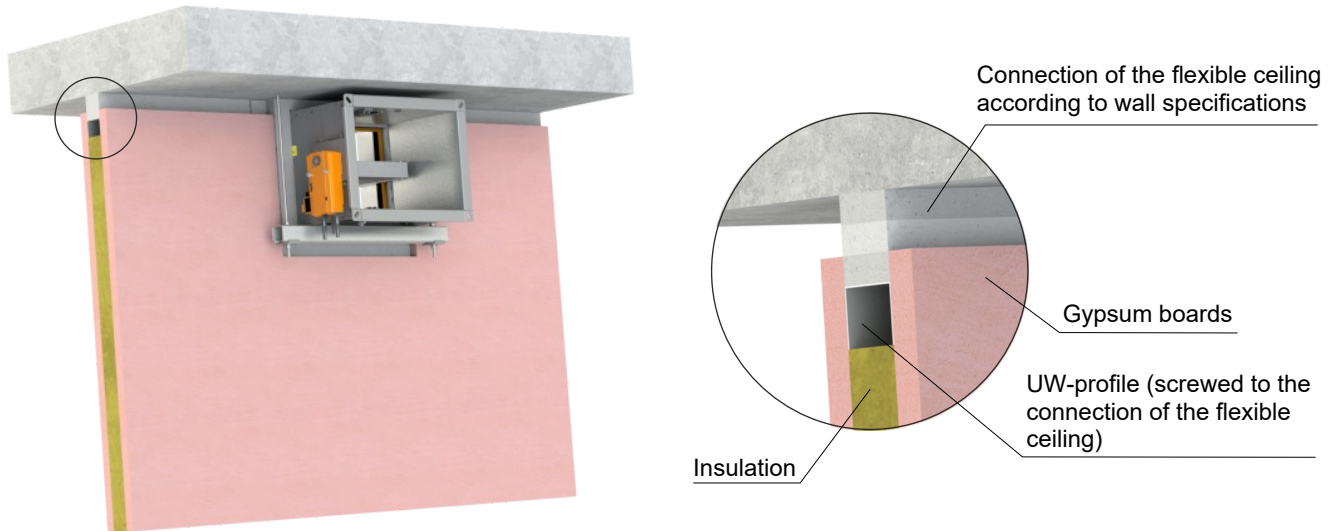

Installation frame	W [mm]	Z [mm]
E5	$B + 224 + X$	$A + 208 + (2 \times F)$

- X = ceiling movement ≤ 40 mm
- F = gap between frame (promaseal) and profile = 2 to 5 mm

Installation at a maximum distance of 80 mm from the ceiling

EI 90 (v_e i↔o) S

- Detailed instructions for installation E5 frame → see manual
- For connection of following duct → see page 78
- Installation frame can be installed on the damper or delivered separately
- Gypsum construction must be made in accordance with the specifications of the wall system manufacturer

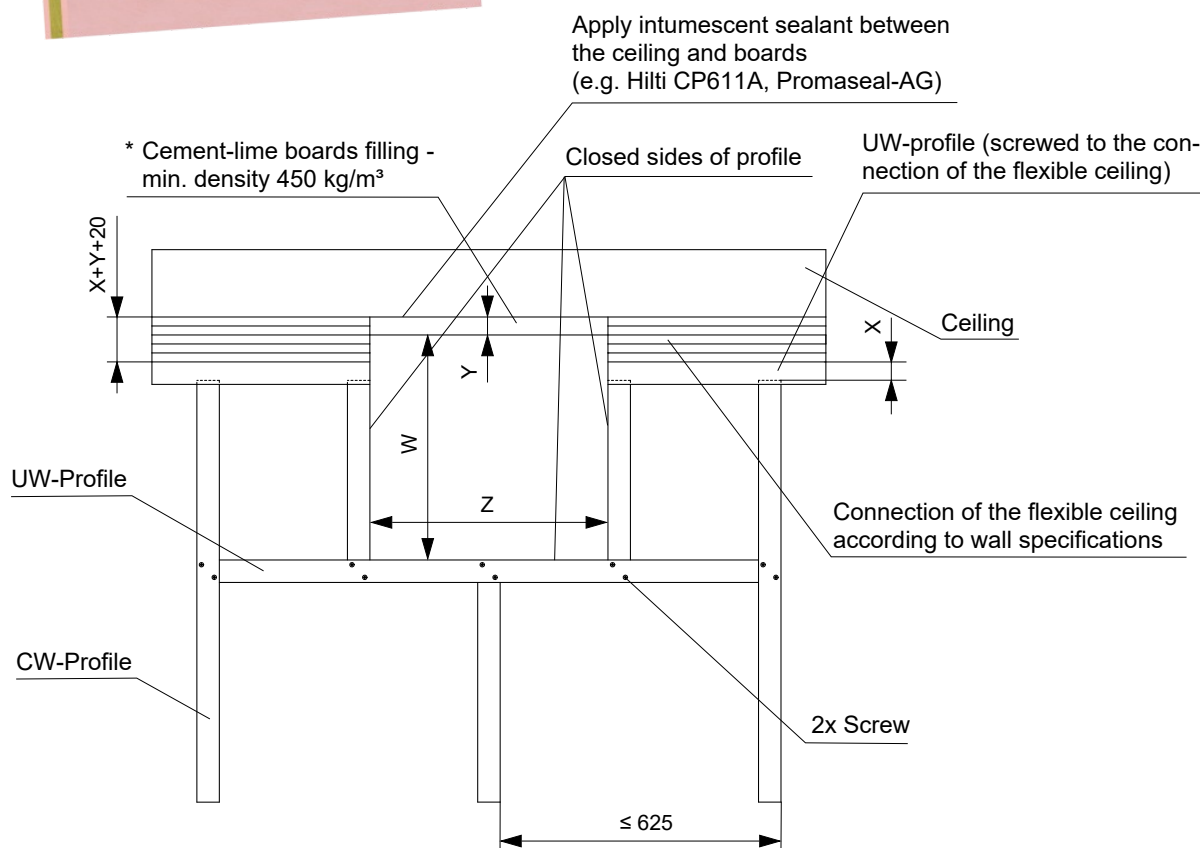
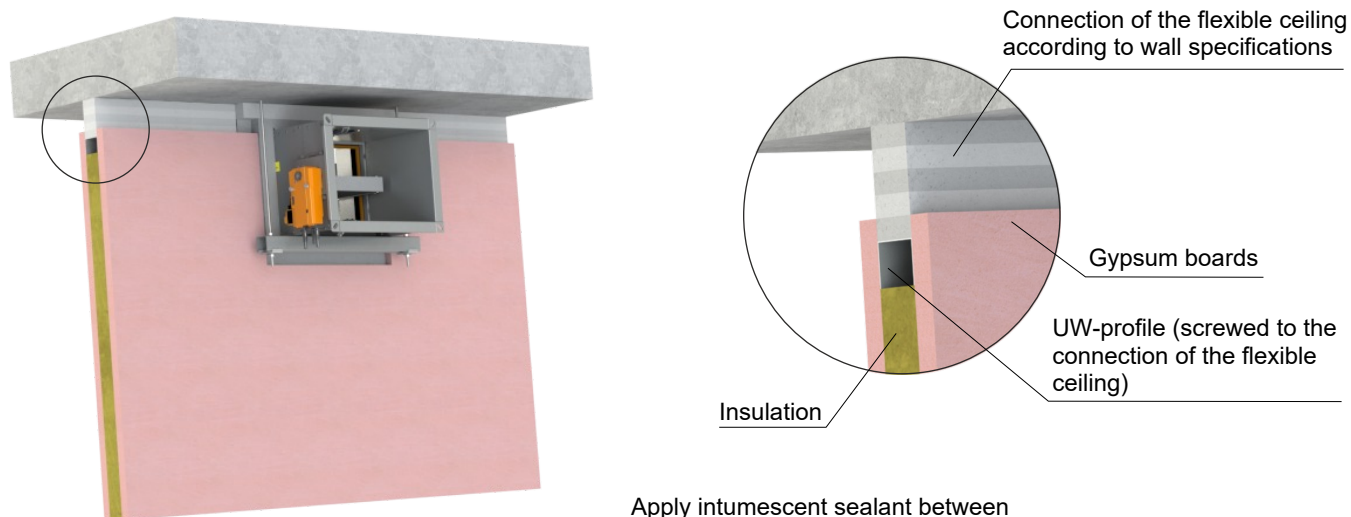

Installation frame	W [mm]	Z [mm]
E5	$B + 224 + X + Y$	$A + 208 + (2 \times F)$

* Width of the boards for frame E5 = 110 mm

- X = ceiling movement ≤ 40 mm
- Y = distance of frame from ceiling max. 80 mm
- F = gap between frame (promaseal) and profile = 2 to 5 mm

Installation frame E6

- Installation frame E6 is designed for installation without additional sealing of the penetration into:
 - Installation outside solid wall/ceiling construction with insulation from fire-resistant boards
- Installation frame is equipped with an intumescent sealing on the inside. This sealing fills the gap between the damper casing and frame in the event of a fire
- Material:
 - Installation frame - cement-lime boards
 - Fasteners - galvanized steel

Installation frame E6

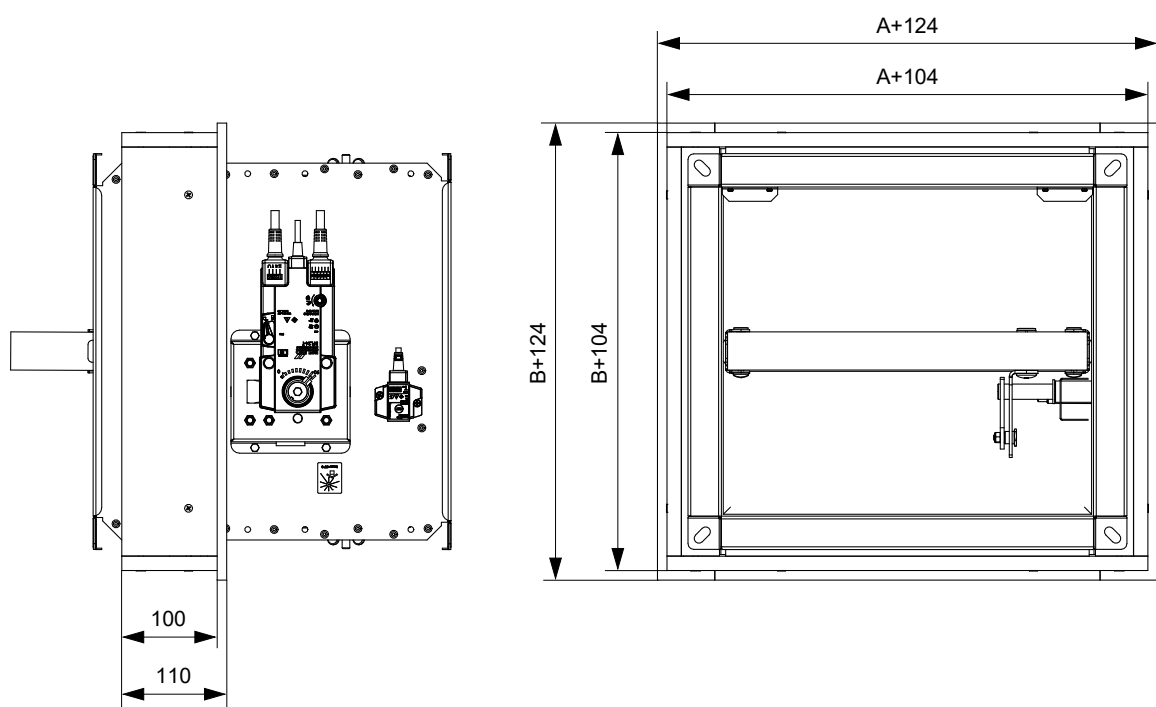
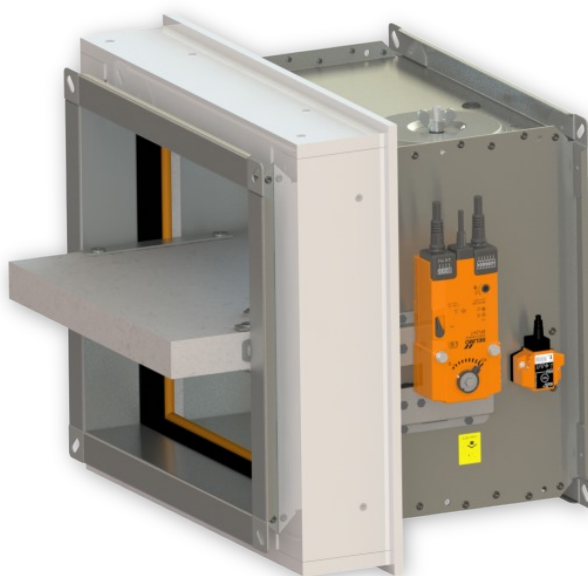

Outside solid wall construction - insulation from fire-resistant boards - mortar or gypsum - installation frame E6

EI 90 (v_e i↔o) S

- For connection of following duct → see page 78
- Minimum and maximum distance between the wall and fire damper is unlimited
- Insulation must be suspended using threaded rods and mounting profiles or other mounting system, according to national standards
- Duct inside the insulation must be suitably supported. The insulation must be suspended at the point of the duct support using threaded rods and mounting profiles
- Load of the suspension system depends on weight of the fire damper, duct system and the insulation → see page 74
- Max. distance between two suspension systems is 1500 mm
- Following air-conditioning duct must be suspended or supported so that all load transfer from the following duct to the fire damper is absolutely excluded
- Adjacent duct must be suspended or supported, as required by the duct suppliers
- Installation frame can be installed on the damper or delivered separately

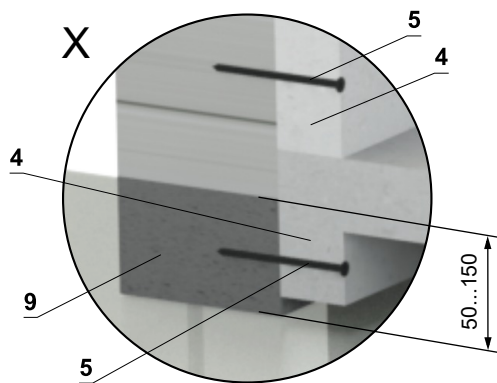

Additional board of duct

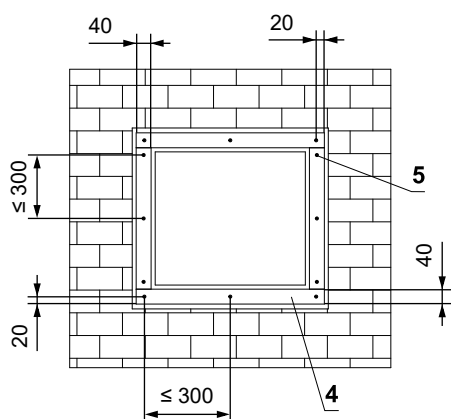

Additional board of frame

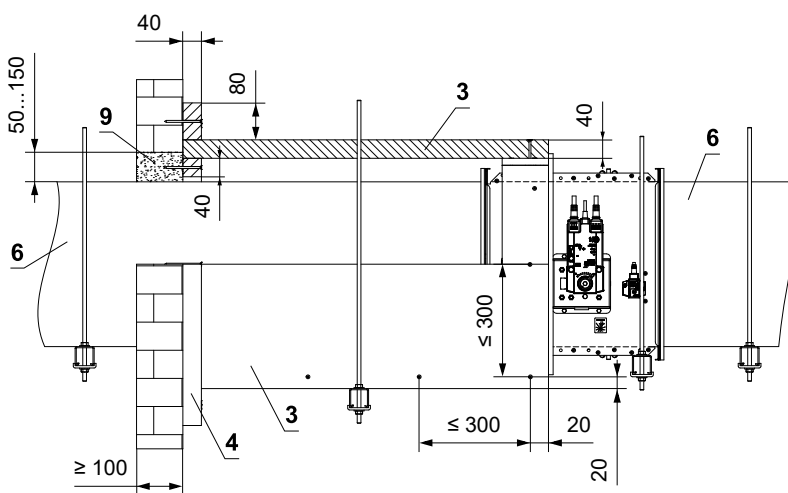
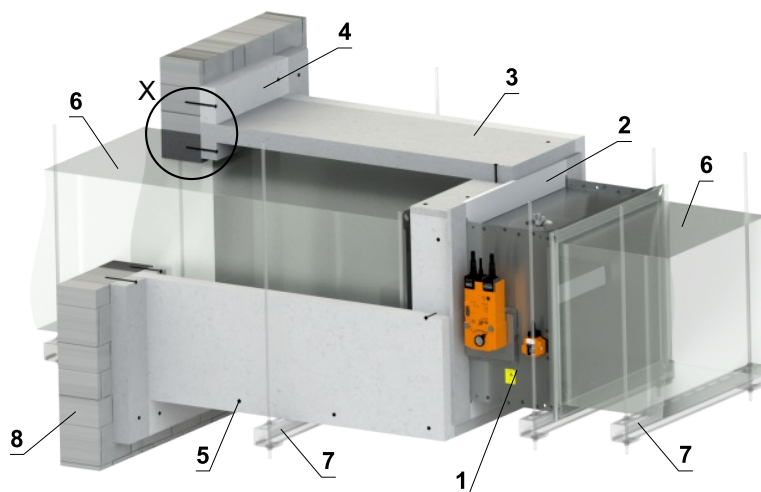
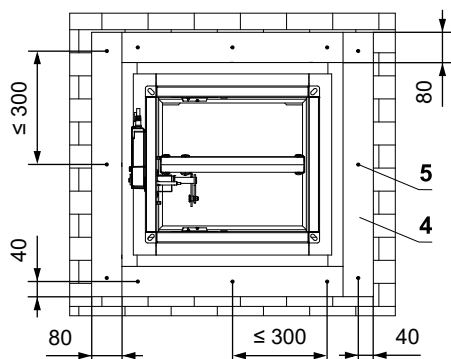

- | | |
|---|---|
| <ul style="list-style-type: none"> 1 FDMQ 2 Installation frame 3 Insulation made of cement-lime board - min. thickness 40 mm, min. density 450 kg/m³ (e.g. PROMATECT-L). All parts are glued with glue Promat K84 and secured with screws 4x80 mm 4 Additional board made of cement-lime board - min. thickness 40 mm, min. density 450 kg/m³ (e.g. PROMATECT-L). Apply HILTI CFS-S ACR mastic at the entire area and secure it with screws 4x80 mm | <ul style="list-style-type: none"> 5 Screw 4x80 mm - screws must be firmly fixed in the wall construction, if necessary use steel anchors 6 Standard air duct, made of galvanized sheet metal min. thickness 0,8 mm – the duct must be anchored on both sides of the fire-separating structure, e.g. using L-profiles 30 × 30 × 3 mm – according to the ISOVER manufacturer's instructions 7 Clamp with threaded rod → see pages 74 to 77 8 Solid wall construction 9 Mortar or gypsum |
|---|---|

Outside solid ceiling construction - insulation from fire-resistant boards - mortar or gypsum - installation frame E6

EI 90 (h_o i↔o) S

- For connection of following duct → see page 78
- Minimum and maximum distance between the ceiling and fire damper is unlimited
- Insulation must be suspended using threaded rods and mounting profiles or other mounting system, according to national standards
- Load of the suspension system depends on weight of the fire damper, duct system and the insulation → see page 74
- Max. distance between two suspension systems is 1500 mm
- Following air-conditioning duct must be suspended or supported so that all load transfer from the following duct to the fire damper is absolutely excluded
- Adjacent duct must be suspended or supported, as required by the duct suppliers
- Installation frame can be installed on the damper or delivered separately
- The damper can be installed from both sides of the construction, i.e. from the top or the bottom side of the ceiling.

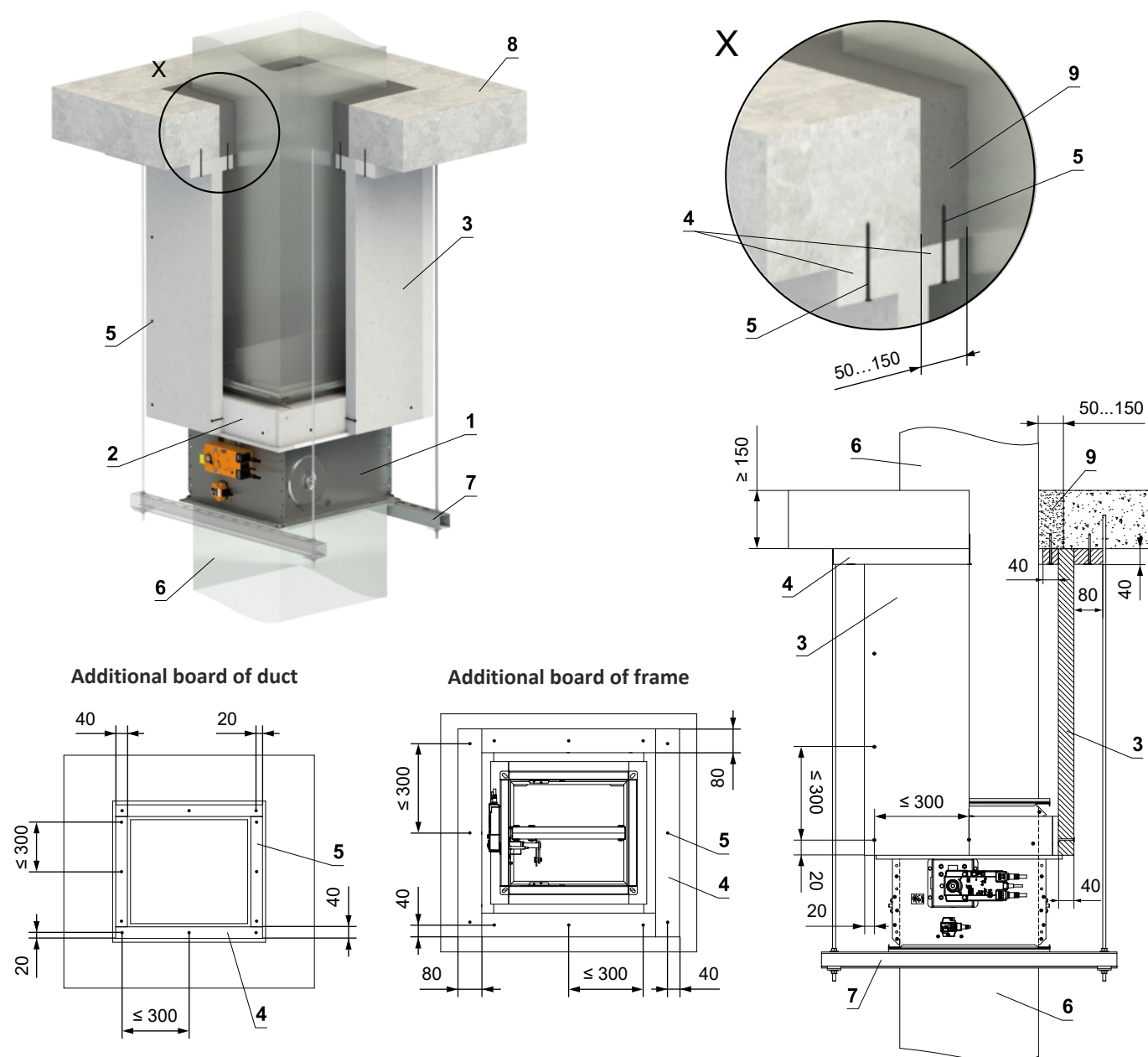

- | | |
|--|---|
| <p>1 FDMQ</p> <p>2 Installation frame</p> <p>3 Insulation made of cement-lime board - min. thickness 40 mm, min. density 450 kg/m³ (e.g. PROMATECT-L). All parts are glued with glue Promat K84 and secured with screws 4x80 mm</p> <p>4 Additional board made of cement-lime board - min. thickness 40 mm, min. density 450 kg/m³ (e.g. PROMATECT-L). Apply HILTI CFS-S ACR mastic at the entire area and secure it with screws 4x80 mm</p> <p>5 Screw 4x80 mm - screws must be firmly fixed in the wall construction, if necessary use steel anchors</p> | <p>6 Standard air duct, made of galvanized sheet metal min. thickness 0,8 mm – the duct must be anchored on both sides of the fire-separating structure, e.g. using L-profiles 30 × 30 × 3 mm – according to the ISOVER manufacturer's instructions</p> <p>7 Clamp with threaded rod → see pages 74 to 77</p> <p>8 Solid ceiling construction</p> <p>9 Mortar or gypsum</p> |
|--|---|

V. SUSPENSION SYSTEMS

Mounting to the ceiling wall

- The dampers must be suspended using threaded rods and mounting profiles. Their dimensioning depend on the weight of the damper.
- The dampers and the duct must be suspended separately.
- Following air-conditioning duct must be suspended or supported so that all load transfer from the following duct to the damper flanges is absolutely excluded. Adjacent duct must be suspended or supported, as required by the duct suppliers.

Examples of anchoring to the ceiling construction Follow the instructions of fixing specialist or installation company

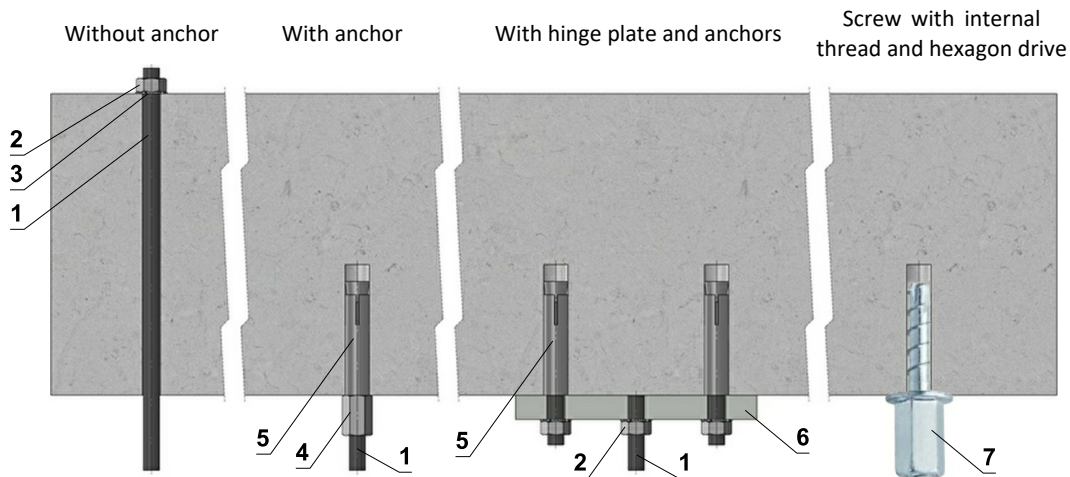

Hinge plates

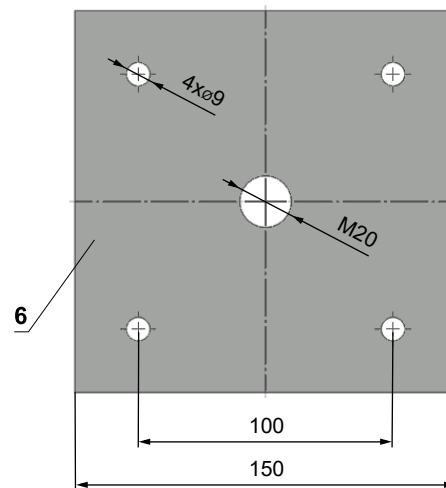
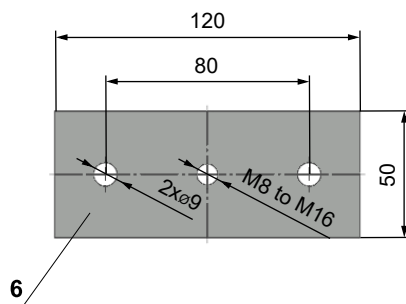

- If in doubt, always consult an anchor specialist engineer such as Halfen or Hilti.

Load capacities of threaded rods at the required fire resistance 60 min. $t \le 120 \text{ min.}$

Size	As [mm ²]	Weight [kg]	
		for 1 rod	for 2 rods
M8	36,6	22	44
M10	58	35	70
M12	84,3	52	104
M16	157	96	192
M18	192	117	234
M20	245	150	300

- 1 Threaded rod M8 - M20
- 2 Nut M8 - M20
- 3 Washer for M8 - M20
- 4 Coupling Nut M8 - M20
- 5 Anchor
- 6 Hinge plate - min. thickness 10 mm
- 7 Concrete screw tested for fire resistance R30-R90, max. Tension up to 0.75 KN (length 35 mm)

Example of placing of mounting profiles HILTI

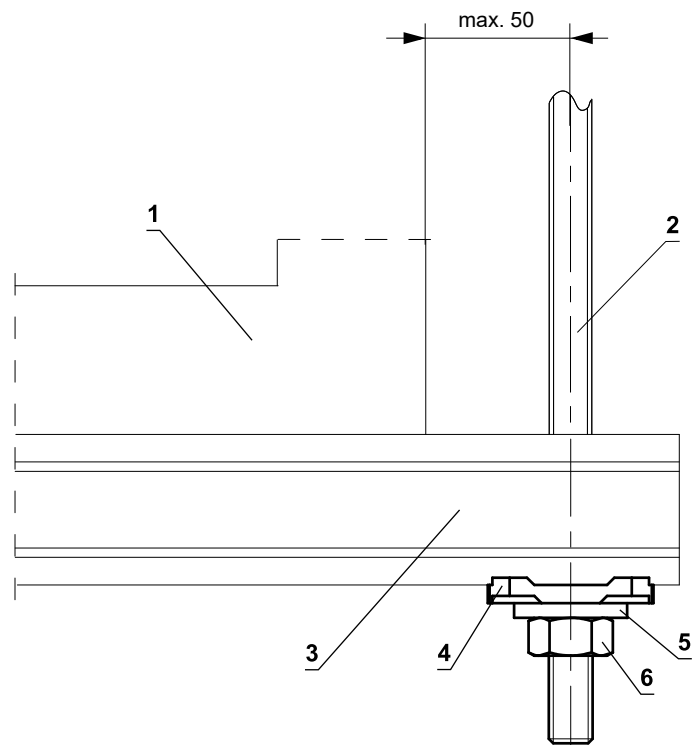
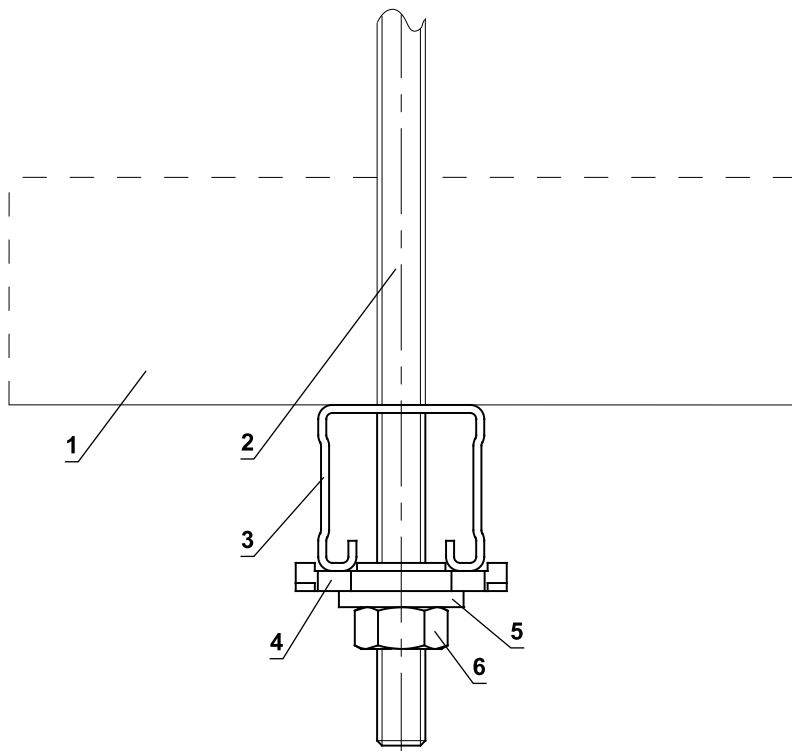

- 1 FDMQ
- 2 Threaded rod M8 - M12
- 3 Support HILTI MQ-41 or MQ-41/3
- 4 Bored plate HILTI MQZ-L
- 5 Washer for M8 - M12
- 6 Nut M8 - M12

Example of fixing FDMQ to the wall ceiling

In solid wall construction

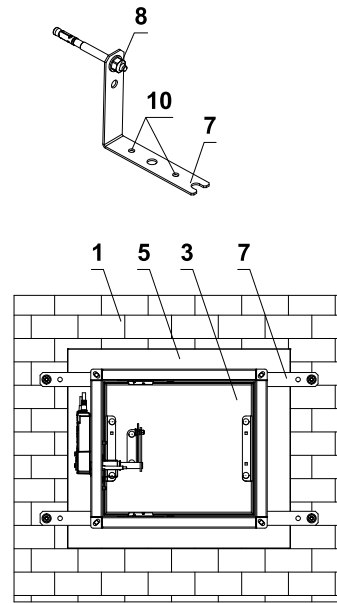
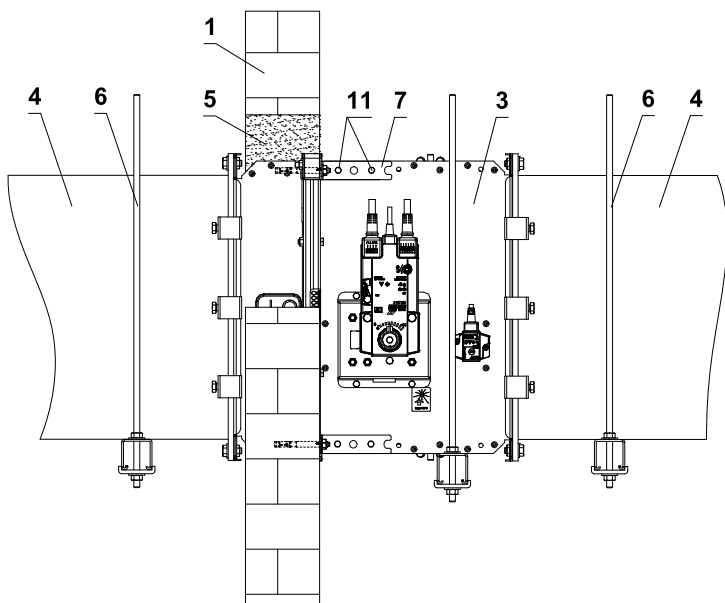

In gypsum wall construction

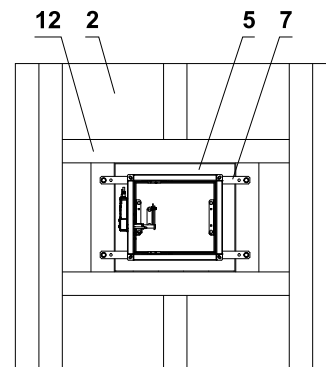
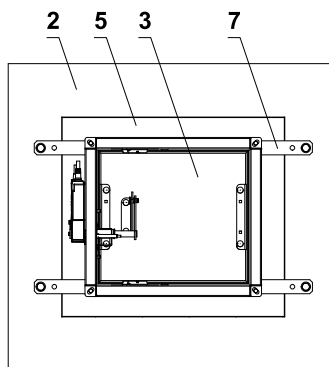
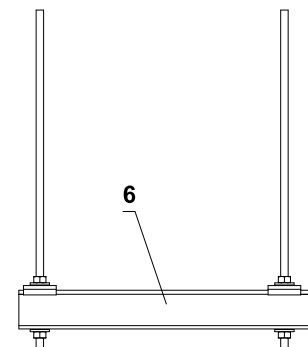
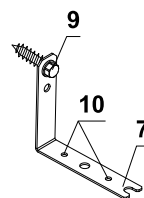
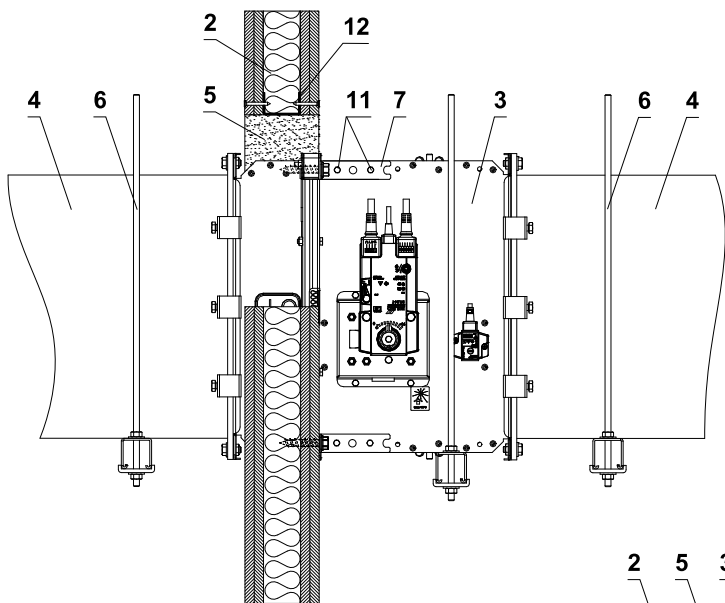

Grid from "U" profile

- 1 Solid wall construction
- 2 Gypsum wall construction
- 3 FDMQ
- 4 Duct
- 5 Penetration
- 6 Profile with threaded rod → see page 75
- 7 Fixing element/steel bracket for fixing the damper to the wall (optional accessories from MANDÍK, a.s. or sheet metal min. thickness 2 mm and min. width 60 mm)
- 8 Nut M8 with anchor
- 9 Hexagon head screw
- 10 Installation holes
- 11 Screw assembly M6 (screw M6x10, nut M6)
- 12 Gypsum grid from "U" profile

■ The method of attachment must follow the minimum requirements for attachment and connection of ductwork in accordance with national regulations. Also, the elements can be suspended from the top, or supported from bottom, or fastened from the side.

Example of fixing FDMQ to the ceiling

In solid ceiling construction

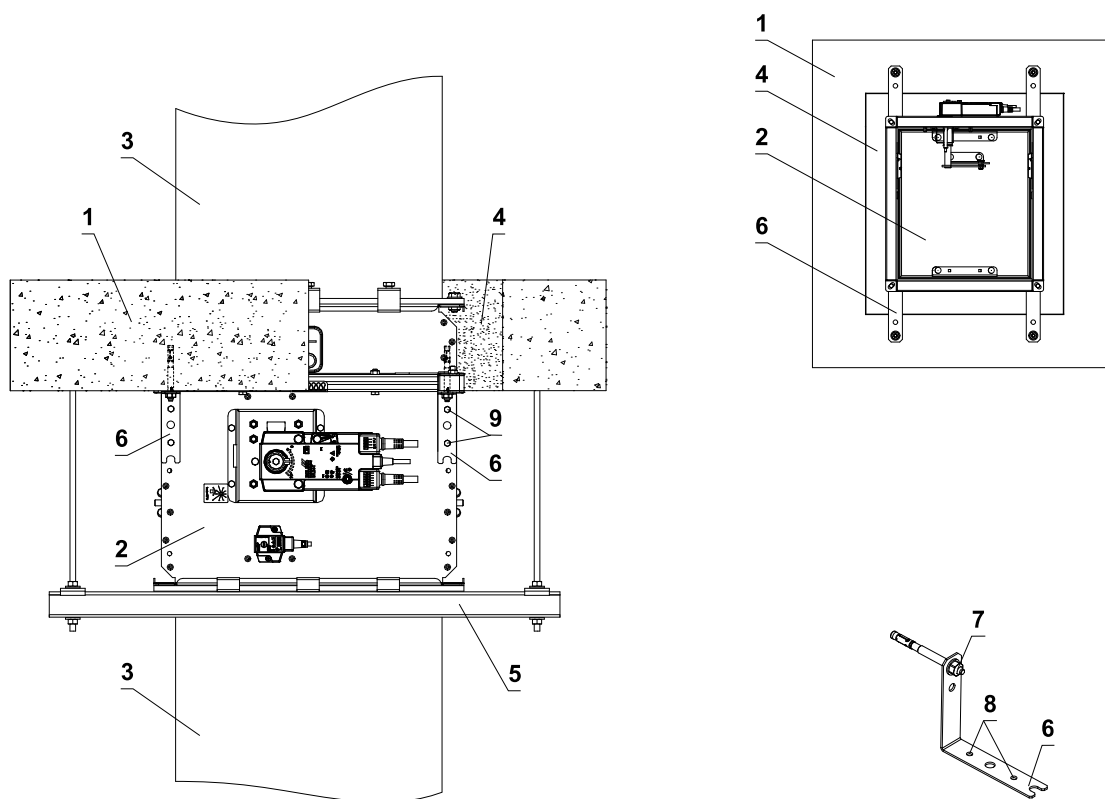

- 1 Solid ceiling construction
- 2 FDMQ
- 3 Duct
- 4 Penetration
- 5 Profile with threaded rod → see page 75
- 6 Fixing element/steel bracket for fixing the damper to the wall (optional accessories from MANDÍK, a.s. or sheet metal min. thickness 2 mm and min. width 60 mm)
- 7 Nut M8 with anchor
- 8 Installation holes
- 9 Screw assembly M6 (screw M6x10, nut M6)

- The method of attachment must follow the minimum requirements for attachment and connection of ductwork in accordance with national regulations. Also, the elements can be suspended from the top, or supported from bottom, or fastened from the side.

Example of duct connection

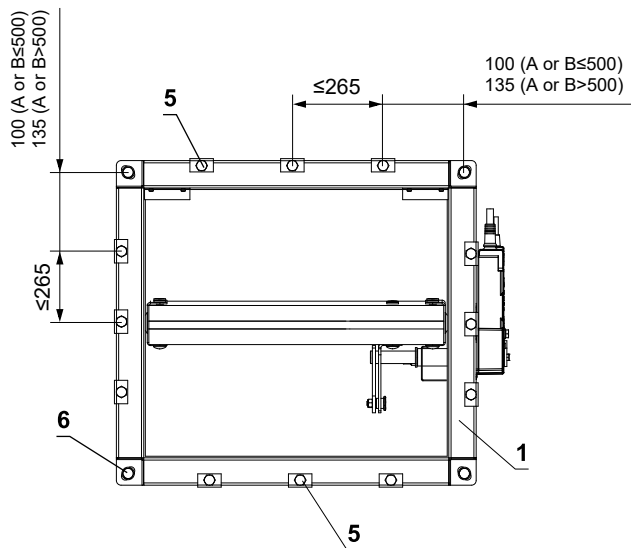
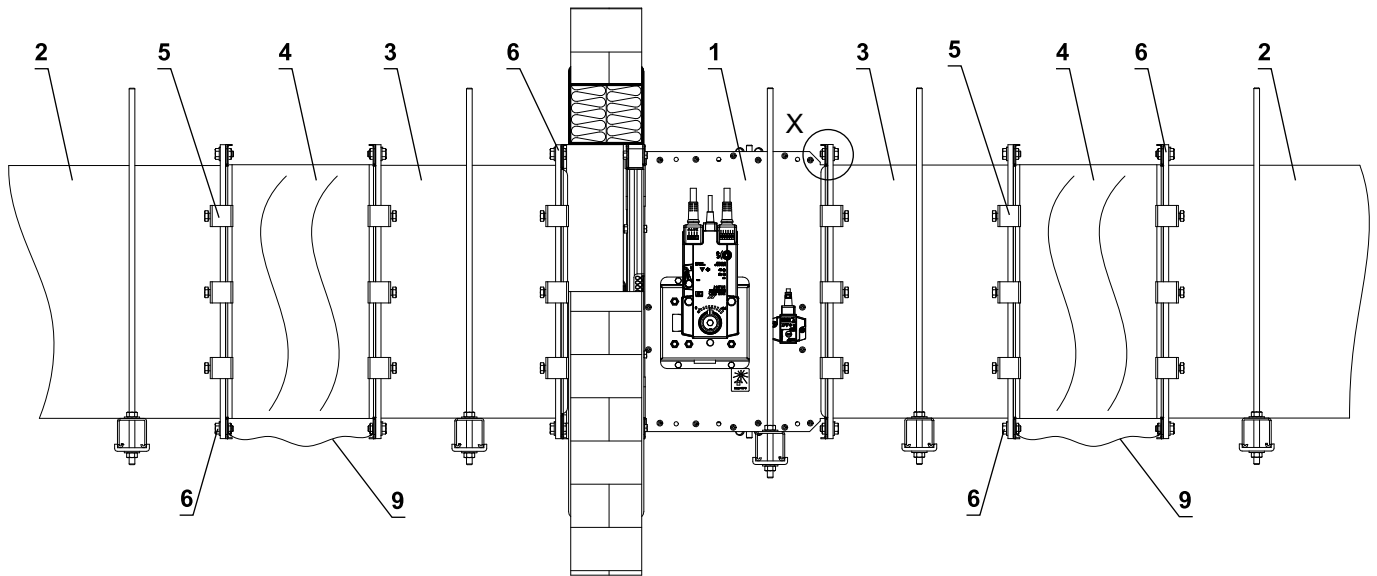

Electrically conductive connection

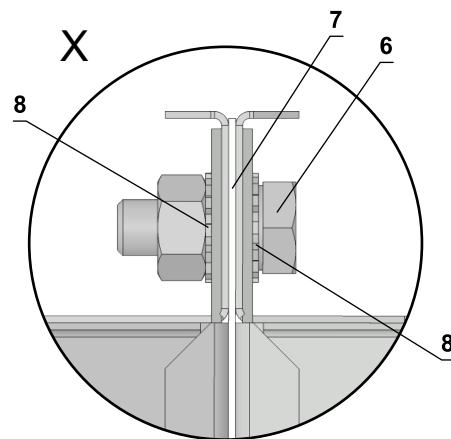

* at least one connection must be electrically conductive

- 1 FDMQ
- 2 Duct
- 3 Extension piece (if required)
- 4 Damping pad
- 5 Steel clamp min. screw M8
- 6 Screw assembly M8 (screw M8x20 mm, 2 pcs toothed lock washer M8, nut M8) *
- 7 Sealing
- 8 Toothed lock washer M8
- 9 Protective bonding conductor

VI. TECHNICAL DATA

Pressure loss

Pressure loss calculation

$$\Delta p = \xi \cdot \rho \cdot \frac{w^2}{2}$$

Δp	[Pa]	pressure loss
w	[m/s]	air flow speed in nominal damper section
ρ	[kg/m ³]	air density
ξ	[-]	coefficient of local pressure loss for the nominal damper section → see page 80

Determination of pressure loss by using diagram $\rho = 1,2 \text{ kg/m}^3$

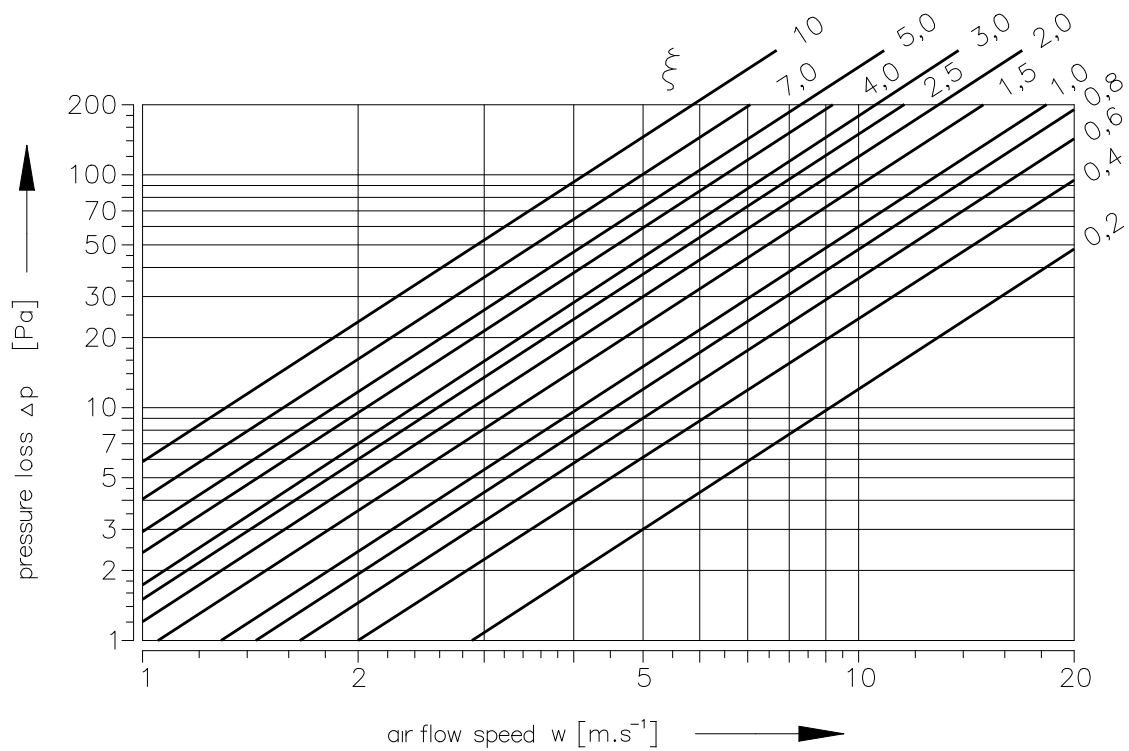

Coefficient of local pressure loss

B	A													
	150	180	200	225	250	280	300	315	355	400	450	500	550	560
150	2,742	2,575	2,399	2,320	2,219	2,105	2,047	1,954	1,885	1,811	1,753	1,703	1,686	1,665
180	2,132	1,992	1,864	1,795	1,721	1,636	1,575	1,502	1,440	1,387	1,342	1,308	1,290	1,275
200	1,691	1,580	1,477	1,417	1,363	1,288	1,244	1,186	1,136	1,094	1,059	1,030	1,017	1,005
225	1,338	1,288	1,161	1,052	1,031	1,003	0,972	0,938	0,892	0,847	0,833	0,806	0,783	0,774
250	1,118	1,042	0,969	0,934	0,902	0,852	0,807	0,776	0,741	0,715	0,691	0,673	0,661	0,655
280	1,030	0,938	0,911	0,873	0,842	0,801	0,752	0,710	0,662	0,641	0,623	0,612	0,605	0,591
300	0,954	0,868	0,821	0,789	0,754	0,710	0,668	0,621	0,594	0,582	0,551	0,543	0,538	0,535
315	0,797	0,740	0,690	0,667	0,639	0,606	0,570	0,548	0,524	0,503	0,486	0,473	0,464	0,460
355	0,685	0,638	0,595	0,568	0,545	0,518	0,492	0,472	0,450	0,433	0,418	0,406	0,399	0,395
400	0,602	0,561	0,522	0,498	0,479	0,453	0,436	0,413	0,395	0,378	0,366	0,355	0,349	0,345
450	0,538	0,500	0,465	0,446	0,429	0,408	0,384	0,367	0,351	0,337	0,325	0,315	0,313	0,307
500	0,491	0,456	0,423	0,407	0,394	0,369	0,352	0,334	0,319	0,306	0,296	0,287	0,284	0,280
550	0,470	0,436	0,404	0,388	0,374	0,352	0,330	0,313	0,304	0,288	0,277	0,275	0,267	0,264
560	0,450	0,417	0,388	0,374	0,356	0,335	0,321	0,305	0,291	0,279	0,270	0,262	0,259	0,255
600	0,423	0,394	0,370	0,354	0,342	0,321	0,304	0,290	0,278	0,271	0,260	0,249	0,244	0,235
630	0,414	0,384	0,357	0,344	0,331	0,311	0,295	0,281	0,268	0,258	0,248	0,241	0,229	0,234
650	–	0,366	0,344	0,330	0,318	0,299	0,287	0,274	0,257	0,248	0,242	0,232	0,221	0,225
700	–	0,363	0,337	0,323	0,311	0,296	0,280	0,266	0,254	0,242	0,236	0,227	0,215	0,214
710	–	0,357	0,332	0,319	0,306	0,291	0,276	0,260	0,249	0,239	0,230	0,223	0,212	0,212
750	–	0,344	0,320	0,312	0,300	0,278	0,263	0,252	0,239	0,231	0,223	0,216	0,213	0,209
800	–	0,335	0,311	0,301	0,289	0,274	0,257	0,244	0,233	0,223	0,215	0,209	0,205	0,203

B	A													
	600	630	650	700	710	750	800	900	1000	1100	1250	1400	1500	
150	1,644	1,628	1,622	1,609	1,605	1,591	1,580	1,551	1,535	–	–	–	–	
180	1,261	1,246	1,234	1,225	1,219	1,208	1,197	1,177	1,162	1,148	1,136	1,124	1,117	
200	0,989	0,981	0,970	0,963	0,960	0,951	0,942	0,926	0,914	0,903	0,892	0,884	0,878	
225	0,768	0,757	0,739	0,732	0,724	0,718	0,712	0,699	0,690	0,681	0,666	0,654	0,650	
250	0,649	0,639	0,631	0,630	0,625	0,620	0,613	0,602	0,595	0,587	0,580	0,574	0,571	
280	0,586	0,583	0,561	0,556	0,551	0,546	0,539	0,532	0,524	0,512	0,499	0,491	0,482	
300	0,522	0,508	0,504	0,503	0,502	0,496	0,488	0,480	0,465	0,455	0,449	0,447	0,440	
315	0,454	0,449	0,443	0,441	0,439	0,433	0,430	0,423	0,417	0,412	0,407	0,402	0,400	
355	0,391	0,386	0,380	0,378	0,377	0,372	0,370	0,363	0,358	0,353	0,349	0,345	0,343	
400	0,342	0,337	0,331	0,330	0,329	0,325	0,323	0,316	0,312	0,308	0,305	0,302	0,299	
450	0,303	0,299	0,295	0,294	0,293	0,290	0,286	0,281	0,278	0,274	0,271	0,267	0,266	
500	0,275	0,272	0,271	0,268	0,266	0,263	0,261	0,256	0,252	0,249	0,246	0,244	0,242	
550	0,261	0,258	0,253	0,248	0,246	0,244	0,243	0,238	0,235	0,232	0,227	0,224	0,223	
560	0,253	0,249	0,246	0,245	0,243	0,240	0,238	0,234	0,230	0,227	0,224	0,222	0,221	
600	0,233	0,232	0,230	0,229	0,228	0,224	0,220	0,218	0,214	0,211	0,208	0,206	0,204	
630	0,232	0,229	0,226	0,225	0,224	0,221	0,218	0,215	0,212	0,209	0,206	0,204	0,202	
650	0,222	0,219	0,217	0,215	0,214	0,212	0,209	0,203	0,201	0,199	0,194	0,191	0,189	
700	0,212	0,212	0,211	0,210	0,208	0,206	0,204	0,201	0,198	0,196	0,193	0,190	0,188	
710	0,210	0,210	0,209	0,208	0,207	0,205	0,203	0,199	0,195	0,193	0,191	0,189	0,187	
750	0,205	0,202	0,200	0,199	0,198	0,197	0,195	0,191	0,187	0,184	0,182	0,180	0,178	
800	0,200	0,198	0,196	0,195	0,194	0,192	0,189	0,186	0,183	0,181	0,178	0,177	0,176	

Noise data

Level of acoustic output corrected with filter A

$$L_{WA} = L_{W1} + 10 \log(S) + K_A$$

L_{WA}	[dB(A)]	level of acoustic output corrected with filter A
L_{W1}	[dB]	level of acoustic output L_{W1} related to the 1 m ² section
S	[m ²]	duct cross section
K_A	[dB]	correction to the weight filter A

Level of acoustic output in octave ranges

$$L_{Woct} = L_{W1} + 10 \log(S) + L_{rel}$$

L_{Woct}	[dB]	spectrum of acoustic output in octave range
L_{W1}	[dB]	level of acoustic output L_{W1} related to the 1 m ² section
S	[m ²]	duct cross section
L_{rel}	[dB]	relative level expressing the shape of the spectrum

Tables of acoustic values

Level of acoustic output L_{W1} [dB] related to the 1 m² section

w [m/s]	ξ [-]																
	0,2	0,3	0,4	0,5	0,6	0,7	0,8	0,9	1	1,5	2	2,5	3	4	5	8	10
2	15,5	18,7	20,9	22,6	24	25,2	26,3	27,2	28	31,2	33,4	35,1	36,5	38,8	40,5	44,2	45,9
3	26,1	29,2	31,5	33,2	34,6	35,8	36,9	37,8	38,6	41,7	44	45,7	47,1	49,4	51,1	54,7	56,5
4	33,6	36,7	39	40,7	42,1	43,3	44,3	45,3	46,1	49,2	51,5	53,2	54,6	56,9	58,6	62,2	64
5	39,4	42,5	44,8	46,5	47,9	49,1	50,2	51,1	51,9	55	57,3	59	60,4	62,7	64,4	68	69,8
6	44,1	47,3	49,5	51,3	52,7	53,9	54,9	55,8	56,6	59,8	62	63,8	65,2	67,4	69,2	72,8	74,5
7	48,2	51,3	53,5	55,3	56,7	57,9	58,9	59,8	60,7	63,8	66,1	67,8	69,2	71,4	73,2	76,8	78,6
8	51,6	54,8	57	58,8	60,2	61,4	62,4	63,3	64,1	67,3	69,5	71,3	72,7	74,9	76,7	80,3	82
9	54,7	57,9	60,1	61,8	63,2	64,4	65,5	66,4	67,2	70,4	72,6	74,3	75,7	78	79,7	83,4	85,1
10	57,4	60,6	62,8	64,6	66	67,2	68,2	69,1	70	73,1	75,3	77,1	78,5	80,7	82,5	86,1	87,9
11	59,9	63,1	65,3	67,1	68,5	69,7	70,7	71,6	72,4	75,6	77,8	79,6	81	83,2	85	88,6	90,3
12	62,2	65,4	67,6	69,3	70,7	71,9	73	73,9	74,7	77,9	80,1	81,8	83,2	85,5	87,2	90,9	92,6

Correction to the weight filter A

w [m/s]	2	3	4	5	6	7	8	9	10	11	12
K_A [dB]	-15	-11,8	-9,8	-8,4	-7,3	-6,4	-5,7	-5	-4,5	-4	-3,6

Relative level expressing the shape of the spectrum L_{rel}

w [m/s]	f [Hz]							
	63	125	250	500	1000	2000	4000	8000
2	-4,5	-6,9	-10,9	-16,7	-24,1	-33,2	-43,9	-56,4
3	-3,9	-5,3	-8,4	-13,1	-19,5	-27,6	-37,4	-48,9
4	-3,9	-4,5	-6,9	-10,9	-16,7	-24,1	-33,2	-43,9
5	-4	-4,1	-5,9	-9,4	-14,6	-21,5	-30,0	-40,3
6	-4,2	-3,9	-5,3	-8,4	-13,1	-19,5	-27,6	-37,4
7	-4,5	-3,9	-4,9	-7,5	-11,9	-17,9	-25,7	-35,1
8	-4,9	-3,9	-4,5	-6,9	-10,9	-16,7	-24,1	-33,2
9	-5,2	-3,9	-4,3	-6,4	-10,1	-15,6	-22,7	-31,5
10	-5,5	-4	-4,1	-5,9	-9,4	-14,6	-21,5	-30
11	-5,9	-4,1	-4	-5,6	-8,9	-13,8	-20,4	-28,8
12	-6,2	-4,3	-3,9	-5,3	-8,4	-13,1	-19,5	-27,6

VII. MATERIAL, FINISHING

- Damper casings are made from galvanized sheet metal without further surface treatment.
- Damper blades are made from fire resistant asbestos free boards made of mineral fibres.
- Manual control have cover made of mechanically resistant and durable plastic and the other parts are galvanized without further surface treatment.
- Thermal fuses are made of sheet brass, thickness 0,5 mm.
- Fasteners and springs are galvanized.
- According to the customer's requirements, dampers can be made of stainless steel material.

Specifications for stainless-steel design:

- Class A2 – Food-grade stainless steel (AISI 304 – EN 1.4301)
- Class A4 – Chemistry-grade stainless steel (AISI 316, 316L – EN 1.4401, EN 1.4404)

The respective stainless steel is the material for all components that are located or entering the damper inner space; components outside the damper casing are typically from galvanised sheet metal (fasteners for mounting the actuator or manual control, mechanical components except Item 4), frame components.

The following components, including the fasteners, are made from stainless steel at all times:

- 1) Damper casing and all components permanently attached
- 2) Blade holders including pins, metal parts of blades
- 3) Control components inside the damper (L-profile, pin with lever, rod, fasteners)
- 4) Parts of a manual control entering the inner space of a damper casing (lower sheet of a manual control, lock holder "1", lock lever "2", closing spring, 8 dia. stopper pin, manual control pin)
- 5) Inspection opening cover including the stirrup and fasteners (if they are parts of the cover)
- 6) Bearing for torque transfer from the lever with pin on the blade L-profile (made from AISI 440C)

The damper blade is made from a board of homogeneous material Promatect- MST, thickness 40 mm or it is composed of two Promatect-H boards, thickness 20 mm, connected by galvanized "U" clips on the outside, sealed with Promat K84 glue.

Thermal fuse is identical for all material variants of the dampers. Upon specification by customer, the thermal fuse can be made from A4 from stainless steel sheet metal.

Thermoelectric activation device BAT is modified for stainless-steel variant of the dampers; standard galvanised screws are replaced with stainless-steel M4 screws of corresponding class. Damper casing has stainless-steel riveting M4 nuts.

Plastic, rubber and silicon components, sealants, foaming tapes, glass-ceramic seals, housings, brass bearings of the blade, actuators, and end switches are identical for all material variants of the dampers.

Some fasteners and components are only available in one class of stainless steel; the type will be used in all stainless-steel variants.

The damper blade in the variant for chemical environments (Class A4) is always treated with a coating of chemically resistant Promat SR.

Any other requirements for the design will be considered atypical and will be addressed on an individual basis.

VIII. TRANSPORTATION, STORAGE AND WARRANTY

Logistic terms

- Dampers are delivered on pallets. As standard, the dampers are wrapped in plastic foil for protection during transport and must not be used for long-term storage. Temperature changes during transport can cause condensation of water inside the packaging and thereby cause corrosion of materials used in the dampers (e.g. white corrosion on zinc-coated items or mould on calcium silicate). Therefore, it is necessary to remove the transport packaging immediately after unloading to allow air to circulate around the product.
- The dampers must be stored in clean, dry, well ventilated and dust-free environment out of direct sunlight. Ensure protection against moisture and extreme temperatures (minimum temperature +5°C). The dampers must be protected against mechanical and accidental damage prior to installation.
- Another required packaging system should be approved and agreed by manufacturer. Packaging material is not returnable in case that another packaging system (material) is required and used and it is not included into final price of damper.
- Dampers are transported by box freight vehicles without direct weather impact, there must not occur any shocks and ambient temperature must not exceed +50°C. Dampers must be protected against impact when transported and manipulated. During transportation, the damper blade must be in the "CLOSED" position.
- Dampers must be stored indoor in environment without any aggressive vapours, gases or dust. Indoor temperature must be in the range from -30°C to +50°C and maximum relative humidity 95%.

Warranty

- The manufacturer provides a warranty of 24 months from the date of dispatch for the dampers.
- In case of using a Schischek actuator, the manufacturer provides a 12-month warranty for the actuator from the date of shipment.
- The warranty for fire dampers FDMQ, provided by the manufacturer, is completely void if actuating, closing and control devices are unprofessionally handled by untrained workers or if electric components, i.e. limit switches, actuators, communication and supply devices and thermoelectric activation devices are dismantled.
- The warranty is void if dampers are used for other purposes, devices and working conditions than those allowed by these technical conditions or if the dampers are mechanically damaged during handling.
- If the dampers are damaged by transport, a record must be written down with the forwarder at reception for later complaint.

IX. ASSEMBLY, ATTENDANCE AND MAINTENANCE

- Assembly, maintenance and damper function check can be done only by qualified and trained person, i.e. "AUTHORIZED PERSON" according to the manufacturer documentation. All works done on the fire dampers must be done according international and local norms and laws.
- All effective safety standards and directives must be observed during damper assembly.
- To ensure reliable damper function it is necessary to avoid blocking the actuating mechanism and contact surfaces with collected dust, fibre and sticky materials and solvents.
- Flange and screw joints must be conductively connected to protect against dangerous contact. 2 galvanized lock washers that are placed under the head of one screw and a fastened nut are used for conductive connection.

Manual operation - actuator control without electric voltage

- A special wrench (part of the actuator) can be used to manually turn the damper blade to any position. When the wrench is turned in the direction of the arrow, the damper blade rotates to its open position. As the blade rotation is stopped, in every position, the actuator will be locked. Unlocking is possible even manually as per instructions on the actuator, or by the activation of the supply voltage.
- If the actuator is manually locked, the damper blade will not close in the event of a fire after the activation of the thermoelectric activation device BAT. To restore correct damper operation, the actuator must be unlocked (manually or by applying power supply).

Limit switches

- If the damper is equipped with limit switches and these switches are not used during operation (e.g. because of a project change), they can be left on the damper and not connected (they need not be dismantled).
- On the other hand, if the limit switch is to be added to the damper design, the change can be implemented by change kit.
- These facts must be recorded in the respective operation documentation of the damper (record books of the damper, fire logs, etc.) and subsequently, adequate function checks must be carried out.

Installation / fixing the damper

- The damper casing shall not be deformed in the course of bricking in.
- Once the damper is built in, the damper blade shall not grind on the damper casing during opening or closing.

Protection of the damper casing against buckling during installation, especially for large sizes!

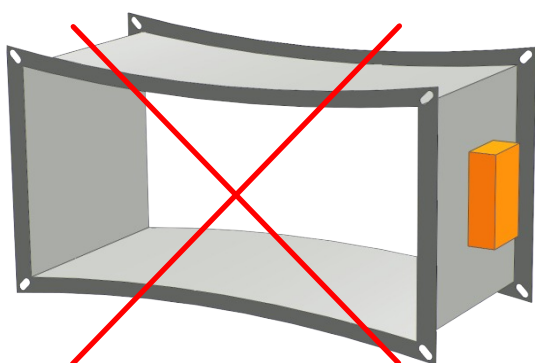

WRONG!

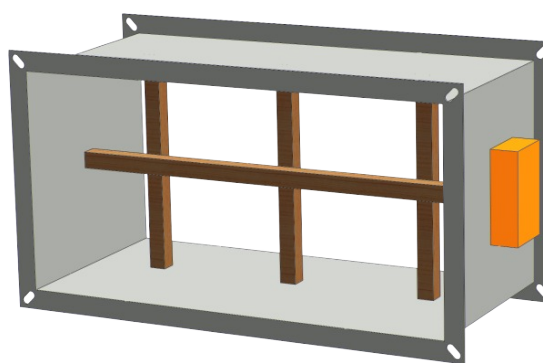

Reinforcement of the casing with wooden beams

Change of manual control for the actuator or vice versa

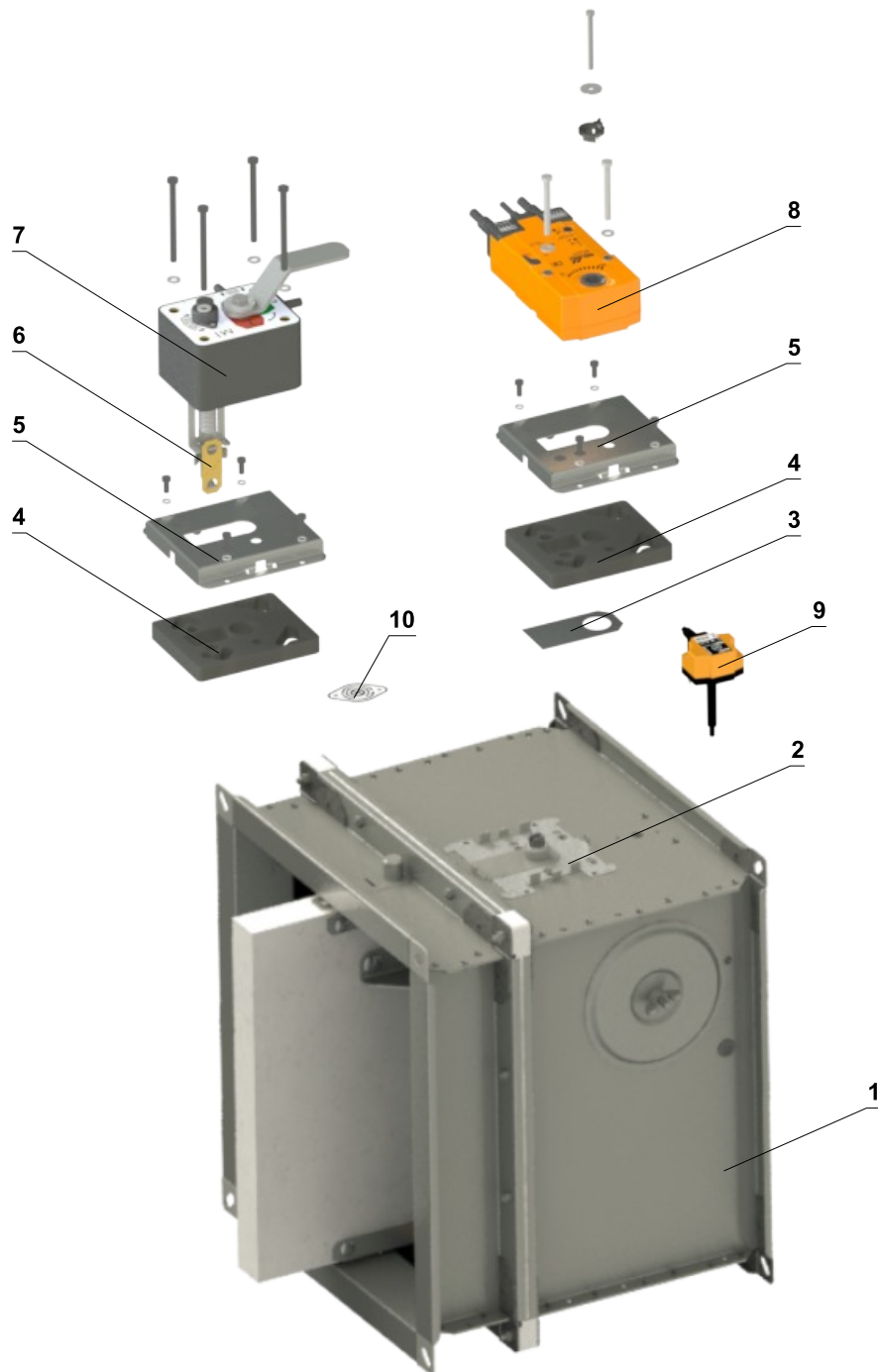

- | | |
|-------------------------------|--|
| 1 Damper | 6 Thermal fuse |
| 2 Mounting plate | 7 Manual control |
| 3 Sealing cover | 8 Spring return actuator |
| 4 Sealing of a mounting plate | 9 Thermoelectric activation device BAT |
| 5 Cover of a mounting plate | 10 Sensor sticker |

Reinforcement frame VRM-Q

- If the damper is installed outside the fire separation construction, a damper side A \geq 800 mm and fire resistance is EI 90 S, VRM-Q reinforcement frame must be used.
- For lower fire resistance than EI 90 S, VRM-Q reinforcement frame is not necessary!
- VRM-Q is mounted only on "A" sides

Fixing of reinforcing frame VRM-Q to the damper casing

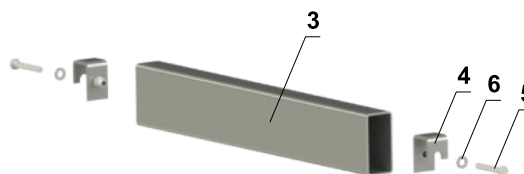
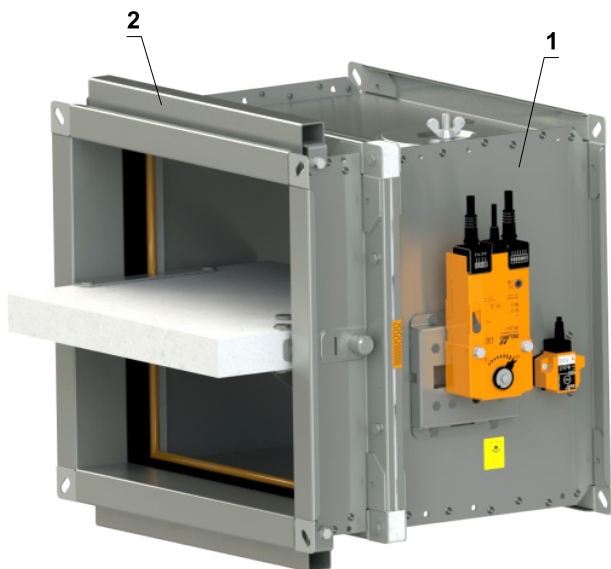

Installation procedure

- 1) Place part A on the damper casing
- 2) Insert part B to the part A
- 3) Adjust a nut of part B against a hole on the damper casing and fasten it with M6x40 mm hexagon head screw DIN 931 with washer M6/6,4 DIN 7349
- 4) Repeat the procedure on the other side of the VRM-Q and an opposite side "A" of the fire damper

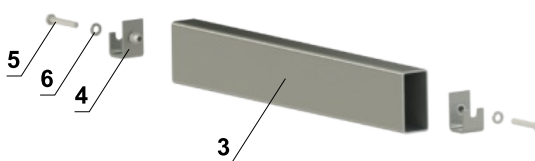
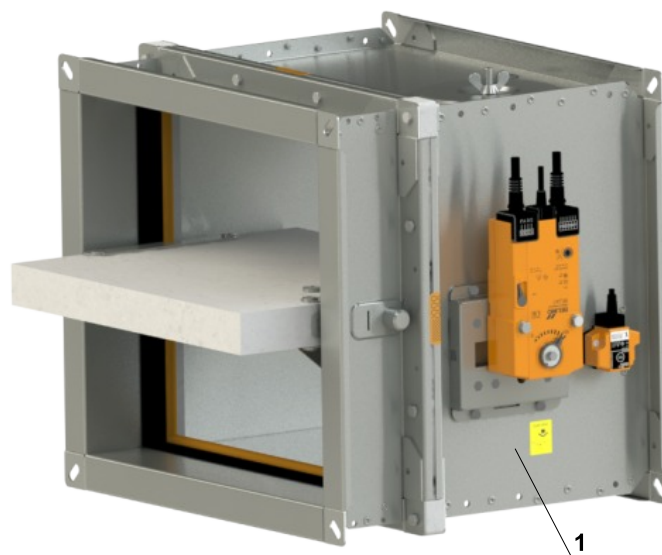

- 1 FDMQ
- 2 VRM-Q
- 3 Part A of VRM-Q
- 4 Part B of VRM-Q
- 5 Hexagon head screw M6x40 mm DIN 931
- 6 Washer M6/6,4 DIN 7349

Protective cladding boards

- Protective cladding boards must be used as part of the penetration filling of installation with Ablative Coated Batt.
- Can be ordered from MANDIK (installed on the damper or as an accessory) or can be sourced from local supplier
- If protective cladding boards are required, this must be specified in the ordering key
- Protective cladding boards are made of PROMATECT-MST, thickness 30 mm.
- Glue K84 is not included in the package

Installation procedure

- 1) Apply K84 glue over the entire surface
- 2) Attach protective cladding boards on all sides of a fire damper and glue them on the damper casing
- 3) Screw parts A and B using four screws 5x70 mm
- 4) Completely fill the gaps with glue

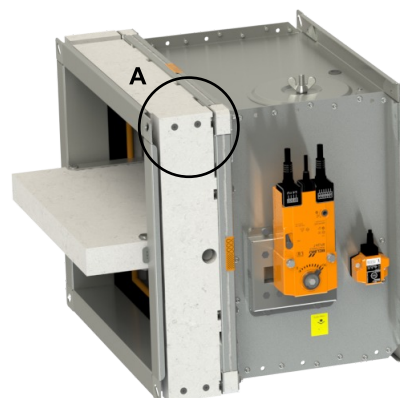

DETAIL A

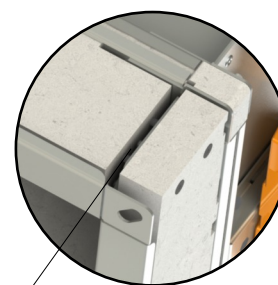

Completely fill the gaps between boards!

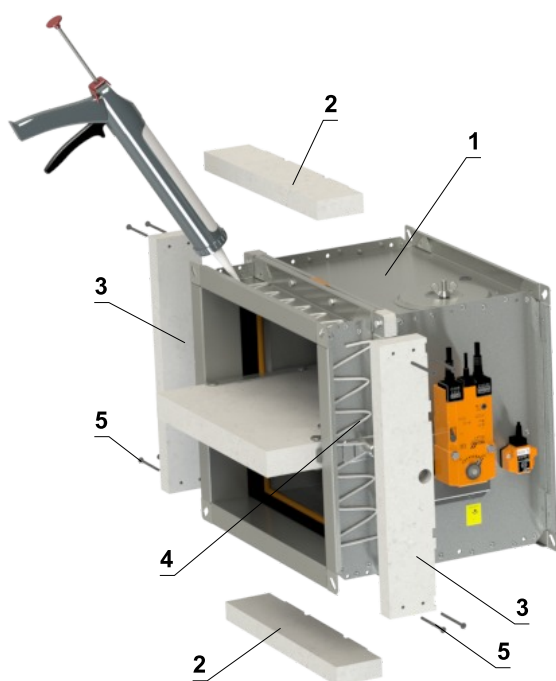

- 1 FDMQ
- 2 Part A
- 3 Part B
- 4 Glue PROMAT K-84
- 5 Screw 5x70 mm

Part A

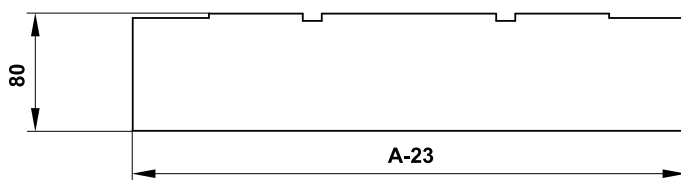

Part B

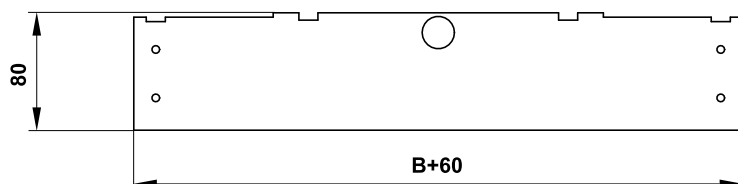

- Detailed dimensions of protective cladding boards on request.

Commissioning and revisions

- Before putting the damper into operation, serviceability checks and functional tests must be carried out including testing of functionality of all electrical elements. After putting into operation these serviceability checks must be carried at least twice a year. If no defect is found during two subsequent serviceability checks, these checks can be carried out once a year.
- In case that dampers are found unable to serve for their function for any cause, it must be clearly marked. The operator is obliged to ensure that the damper is put into condition in which it is ready for function and meanwhile he is obliged to provide the fire protection by another appropriate way.
- Results of regular checks, imperfections found and all-important facts connected with the damper function must be recorded in the "FIRE BOOK" and immediately reported to the operator.
- Before entering the dampers with actuator into operation after their assembly and by sequential checks. Check of blade rotation into the breakdown position "CLOSED" can be done after disconnecting the actuator supply (e.g. by pressing the test button at the thermoelectric activation device BAT or disconnecting the supply from ELECTRICAL FIRE SIGNALISATION). Check of blade rotation back into the "OPEN" position can be done after restoration of power supply (e.g. by releasing the test button or restoration of supply from ELECTRICAL FIRE SIGNALISATION). Without power supply, the damper can be operated manually and fixed in any required position. Release of the locking mechanism can be achieved manually or automatically by applying the supply voltage. It is recommended to provide periodical checks, maintenance and service actions on fire equipment by authorized persons. The authorized persons can be trained by producer, or by authorized distributor. All effective safety standards and directives must be observed during fire damper assembly.
- Visual inspection of proper damper installation, inner area of a damper, damper blade, contact surfaces and silicon seal.
- For regular or exceptional inspection of interior of fire damper, micro-camera device can be used. On each fire damper is an inspection opening. In the case of inspection by camera, take out the black rubber cap, insert the camera inside the damper, check interior and at the end of inspection, put the rubber cap back tightly to cover the empty hole.

For dampers with manual control, following checks must be carried out

Check of a manual control and thermal fuse

- **To check the function of the manual control proceed as follows:**
- Turn the damper blade to "CLOSED" position as follows:
 - The damper blade is in "OPEN" position.
 - Press the control button of the manual control to turn the damper blade to "CLOSED" position.
 - Check the damper blade rotation to "CLOSED" position.
 - Damper blade closing shall be smooth and fast, the control lever shall be in „CLOSED“ position.
- Turn the damper blade to "OPEN" position as follows:
 - Turn the control lever by 90°.
 - Check the damper blade rotation to "OPEN" position.
 - The lever will automatically lock in "OPEN" position.
- **Check of function and condition of the thermal fuse:**
 - To check the function and the status of the fuse it's possible to remove the manual control from the casing of the fire damper which is attached to the damper casing with four screws M6.
 - Removing the thermal fuse from the fuse holder of a manual control, checks its correct functionality.
 - The manual control is identified as M2 to M5, depending on the closing spring strength.

For dampers with actuators, following checks must be carried out

- Check the rotation of the blade to "CLOSED" failure position after disconnection the power supply of the actuator (e.g. by pressing the test button on the thermoelectric activation device BAT or by disconnection the power supply from electrical fire signalization). Check the rotation of the blade back to "OPEN" position by restoring the power supply to the actuator (e.g. by releasing the test button or by restoring the power supply from electrical fire signalization).

Before putting the dampers into operation and during subsequent function checks, the following checks must be carried out for dampers with optical smoke detector

- The function checks of the optical smoke detector are to be carried out by employees of an authorized organization who have corresponding electrotechnical qualification and have been properly trained by the manufacturer. The function checks are to be carried out as a part of function checks of the fire dampers, at least 1x a year.
- For the function checks, the damper blade should be in "CLOSED" position with the fan off or with closed air regulation situated between the fan and the fire damper.
- Inspection opening disassembly
 - Release the covering lid by turning the wing nut and while turning the lid right or left release it from the security belt. Then tilt the lid and remove it from its original position.

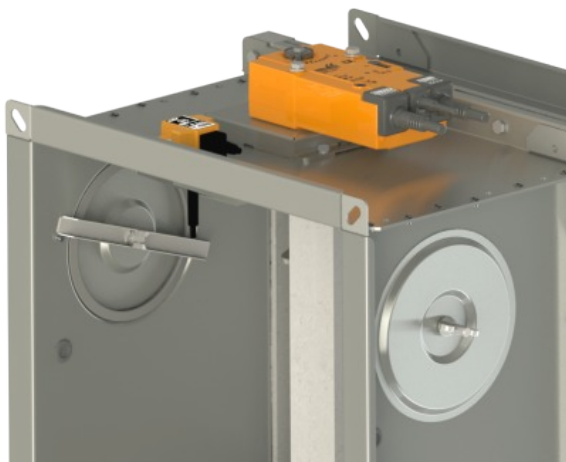

Inspection opening detail

- Ensure each damper is fully checked for operational capability, control should be initiated from the control system or by manual control. Damper blades should open and close correctly and operation should be visually inspected and documented prior to handover.

How to proceed after Tf1 or Tf2 fuses have been activated

- If the thermal fuse **Tf1** is interrupted (due to temperature outside the duct), it is necessary to replace the spring return actuator. → see page 10
- If the thermal fuse **Tf2** is interrupted (due to temperature inside the duct) , only the spare part ZBAT 72 (95/120/140) needs to be replaced (acc.to the activation temperature). → see page 10

X. ORDERING INFORMATIONS

Ordering key



EXAMPLES:

FDMQ EN 500x250/375 .40 Q30-ZN

Fire damper FDMQ, dimension 500x250 mm, built length 375 mm, control design with spring return actuator AC 230 V, standard activation temperature 72 °C, flange dimension 30 mm, galvanized material variant, without installation kit/frame, standard silicon seal.

FDMQ EN 500x250/375 .40 120 E1 Q30-ZN IW G

Fire damper FDMQ, dimension 500x250 mm, built length 375 mm, control design with spring return actuator AC 230 V, activation temperature 120 °C, with installation frame E1, flange dimension 30 mm, galvanized material variant, impregnation against humidity, rubber cold seal.

1| Fire damper type - FDMQ

2| Country of destination

3| Damper dimensions A x B → see pages 16 to 21

"A" is the width of the damper
 "B" is the height of the damper

4| Built length - 375 mm

5| Damper design

.01	Manual control and thermal
.02	Manual control and thermal (Zone 1,2)
.11	Manual control and thermal with a terminal switch („CLOSED“)
.12	Manual control and thermal with a terminal switch („CLOSED“) (Zone 1,2)
.80	Manual control and thermal with two terminal switches („OPEN“, „CLOSED“)
.81	Manual control and thermal with two terminal switches („OPEN“, „CLOSED“) (Zone 1,2)
.40	With actuator BF 230-TN (BFL, BFN 230-T) - voltage AC 230 V
.41	With actuator BF 24-TN (BFL, BFN 24-T), with smoke detector ORS 142 K and with supply device BKN 230-24-MOD (voltage AC 230 V)
.42 *	With actuator ExMax-15-BF, with thermoelectric activation device ExPro-TT (Zone 1,2) - supply voltage range 24 to 230 VAC/DC
.50	With actuator BF 24-TN (BFL, BFN 24-T) - voltage AC/DC 24 V
.51	With actuator BF 24-TN (BFL, BFN 24-T), with smoke detector ORS 142 K (voltage AC/DC 24 V)
.63	With communication and supply device BKN 230-24-MOD, with actuator BF 24-TN-ST (BFL, BFN 24-T-ST)
.63S	With communication and supply device BKN 230-24-MOD, with actuator BF 24-TN-ST (BFL, BFN 24-T-ST) and with smoke detector ORS 142 K

* These designs are supplied only with an activation temperature of 72 °C.

- If dampers with installation frame are required, that must be specified separately in the order. The installation frame can be installed on the damper or delivered separately.
- Detailed information for ATEX dampers (ZONE 1,2) → see Appendix

6| Activation temperature

Manual control		Spring return actuator control	
	72 °C *		72 °C *
104	104 °C	95	95 °C
147	147 °C	120	120 °C
		140	140 °C

* Standard activation temperature

8| Flange dimension

Q30	Flange width 30 mm
Q20	Flange width 20 mm

9| Material and other design options

ZN	Galvanized
A2	Stainless steel 1.4301 (AISI 304)
A4	Stainless steel 1.4404 (AISI 316L) - included damper blade impregnation against chemical - type PROMAT SR

10| Surface treatment

	Without surface treatment
IW	Damper blade impregnation, impregnating agent PROMAT 2000 - impregnation against humidity
IA	Damper blade impregnation, impregnating agent PROMAT SR - impregnation against chemical

11| Cold seal variant

	Silicone rubber *
G	Silicone-free rubber

* Standard cold seal

7| Installation kit/frame

	Without installation kit/frame
A	With protective cladding boards (for Ablative Coated Batt installation)
VRM-Q	Reinforcing frame VRM-Q
E1	Installation frame E1
E2*	Installation frame E2
E3*	Installation frame E3
E4*	Installation frame E4
E5	Installation frame E5
E6	Installation frame E6

* Available only for dampers with a built length of 375 mm

** Only comes installed on the damper and cannot be purchased separately

Accessories

Protective cladding boards



1| Accessory type - cladding boards

2| Fire damper type - FDMQ

3| Damper dimensions A x B → see pages 16 to 21

Reinforcing frame VRM-Q



1| Accessory type - reinforcing frame VRM-Q

2| Fire damper type - FDMQ

3| Damper dimensions A x B → see pages 16 to 21

Installation frame E

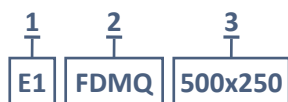



1| Installation frame type E1/E2/E3/E4/E5/E6

2| Fire damper type - FDMQ

3| Damper dimensions A x B → see pages 16 to 21

Data label

- Data label is placed on the damper casing (example)

MANDÍK [®]		MANDÍK, a.s. Dobříšská 550, 267 24 Hostomice, Czech Republic	
FIRE DAMPER - XXXX			
DIMENSION:		DESIGN:	
SERIAL.NO.:		WEIGHT (kg):	
CLASSIFICATION:		MANUAL	
TPM XXX/XX	Cert. No.: 1391-CPR-XXXX/XXXX, DoP: PM/XXXX/XX/XX/X	XX	EN 15650:2010
			 1391

The producer reserves the right for innovations of the product.
For actual product information see www.mandik.com

MANDÍK[®]
www.mandik.com

